

**COATS
BADA**

AMMCO

700 Solid State

COATS Computer Wheel Balancer

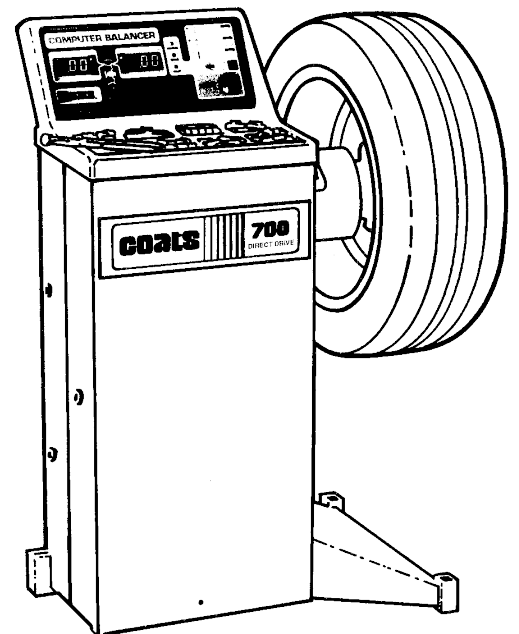

Installation and Operation Instructions *with Maintenance Instructions and Parts Identification*

READ these instructions before placing unit in service
KEEP these and other materials delivered with the
unit in a binder near the machine for ease of reference
by supervisors and operators.

Manual Part No.: 111807
Revision Date: 3/00 rev.1

HENNESSY INDUSTRIES, INC.

P.O. Box 3002, 1601 J. P. Hennessy Drive, LaVergne, TN USA 37086 615/641-7533 800/688-6359

HENNESSY INDUSTRIES INC. Manufacturer of AMMCO®, COATS® and BADA® Automotive Service Equipment and Tools.

Table of Contents

Before You Begin

- Receivingvi
- Specificationsvi
- Electrical Requirementsvi
- Featuresvi
- Standard Accessoriesvi
- Optional Accessoriesvi

Assembly and Setup

- Floor and Space Requirements1
- Unpacking the Unit1
- Remove Balancer from Pallet1
- Connecting to Power1
- Initial Testing1

Operating the Balancer

- Wheel Mounting2
- Selecting Operating Options3
- Entering Wheel Measurements4
- Balance the Wheel4
- Alloy Balancing5
- Static Balancing5

Maintenance and Service

- Preventative Maintenance6
- Service6
- Calibration Check Procedure6
- Calibration Procedure6

Troubleshooting

- Special Problems7
- Operator Complaints7

Parts Identification

- Parts Identification8
- Model 700 Balancer Parts Id. Diagram9

IMPORTANT SAFETY INSTRUCTIONS

1. Read all instructions
2. Do not operate equipment with a damaged cord or if the equipment has been dropped or damaged – until it has been examined by a qualified serviceman.
3. Do not let cord hang over edge of table, bench, or counter, or come in contact with hot manifolds or moving fan blades.
4. If an extension cord is necessary, a cord with a current rating equal to or more than that of the equipment should be used. Cords rated for less current than the equipment may overheat. Care should be taken to arrange the cord so that it will not be tripped over or pulled.
5. Always unplug equipment from electrical outlet when not in use. Never use the cord to pull the plug from the outlet. Grasp plug and pull to disconnect.
6. To reduce the risk of fire, do not operate equipment in the vicinity of open containers or flammable liquids (gasoline).
7. Adequate ventilation should be provided when working on internal combustion engines.
8. Keep hair, loose clothing, fingers, and all body parts away from moving parts.
9. To reduce the risk of electrical shock, do not use on wet surfaces or expose to rain.
10. Use only as described in this manual. Use only manufacturer's recommended attachments.
11. ALWAYS WEAR SAFETY GLASSES. Everyday glasses only have impact resistant lenses, they are NOT safety glasses.
12. Do not disable the hood safety interlock system, or in any way shortcut safety controls and operations.
13. Be sure wheels are mounted properly, the hub nut engages the arbor not less than 4 turns, and the hub nut is firmly tightened before spinning the wheel.
14. Maintain all electrical cords in good repair. Do not operate damaged equipment until it has been examined by a qualified service technician.
15. Be sure the balancer is properly connected to the power supply and electrically grounded.
16. Read and understand this manual before operating. Abuse and misuse will shorten functional life.
17. Keep guards and safety features in place and in working order.
18. Wear proper clothing. Safety toe, non-slip footwear and protective hair covering to contain hair are recommended. Do not wear jewelry, loose clothing, neckties, or gloves when operating the balancer.
19. Keep work area clean and well lighted. Cluttered and/or dark areas invite accidents.
20. Disconnect balancer before servicing.
21. Repair or replace any part that is damaged or worn and that may cause unsafe balancer operation. Do not operate damaged equipment until it has been examined by a qualified service technician.
22. Never overload or stand on the balancer.
23. Do not allow untrained persons to operate machinery.

SAVE THESE INSTRUCTIONS

Definitions of Hazard Levels

Identify the hazard levels used in this manual with the following definitions and signal words:

DANGER

Watch for this symbol:



It Means: Immediate hazards which will result in severe personal injury or death.

WARNING

Watch for this symbol:



It Means: Hazards or unsafe practices which could result in severe personal injury or death.

CAUTION

Watch for this symbol:



It Means: Hazards or unsafe practices which could result in minor personal injury or product or property damage.



Watch for this symbol. It means BE ALERT! Your safety, or the safety of others, is involved.

Owner's Responsibility



To maintain machine and user safety, the responsibility of the owner is to read and follow these instructions:

- Follow all installation instructions and make sure installation conforms to all applicable Local, State, and Federal Codes, Rules, and Regulations; such as State and Federal OSHA Regulations and Electrical Codes.
- Carefully check the unit for correct initial function.
- Read and follow the safety instructions. Keep them readily available for machine operators.
- Make certain all operators are properly trained, know how to safely and correctly operate the unit, and are properly supervised.
- Allow unit operation only with all parts in place and operating safely.
- Carefully inspect the unit on a regular basis and perform all maintenance as required.
- Service and maintain the unit only with authorized or approved replacement parts.
- Keep all instructions permanently with the unit and all decals/labels/notices on the unit clean and visible.



Failure to follow danger, warning and caution instructions may lead to serious personal injury to operator or bystander, or damage to property. Do not operate this machine until you read and understand all the dangers, warnings and cautions in this manual. For additional copies of either, or further information, contact:

**Hennessy Industries
P.O. Box 3002, 1601 J.P. Hennessy Drive
LaVergne, TN 37086-1982
615/641-7533 or 800/688-6359**

Before You Begin

Receiving

The shipment should be thoroughly inspected as soon as it is received. The signed bill of lading is acknowledgement, by the carrier, of receipt in good condition of the shipment covered by our invoice.

If any of the goods called for on this bill of lading are shorted or damaged, do not accept them until the carrier makes a notation of the shorted or damaged goods on the freight bill. Do this for your own protection.

NOTIFY THE CARRIER AT ONCE if any hidden loss or damage is discovered after receipt and request him to make an inspection. If the carrier will not do so, prepare an affidavit to the effect that you have so notified the carrier (on a certain date) and that he has failed to comply with your request.

IT IS DIFFICULT TO COLLECT FOR LOSS OR DAMAGE AFTER YOU HAVE GIVEN THE CARRIER A CLEAR RECEIPT.

File your claim with the carrier promptly. Support your claim with copies of the bill of lading, freight bill, invoice, and photographs, if possible.

Although Coats responsibility ceases upon delivery of the shipment to the carrier, we will gladly assist in tracing lost shipments. Our willingness to assist in every possible manner does not make Coats responsible for collection of claims, or replacement of lost or damaged materials.

Specifications

- Cycle time 10 seconds (avg.)
- Tire/Wheel Weight 56 pounds max.
- Wheel Diameter Range 4 to 34.0 inches
- Wheel Width Range 2 to 18.6 inches
- Balancing Increments
 - Normal Mode 0.25-ounce (7 grams)
 - Fine Balance Mode 0.01-ounce (2.8 grams)(5-gram increments from 5 to 50 grams 10-gram increments from 50 to 100)
- Motor
 - Modified torque with 850 RPM rating, large housing for heat dissipation, and heavy duty insulation for high temperature applications.
- Shipping Weight 260 pounds

Electrical Requirements

The balancer requires a 110 VAC, 50/60Hz, single-phase power supply with 15 amp fuse or circuit breaker and properly grounded three-pin safety outlet.

Features

- Exclusive Direct Drive System - No Pulleys or Belts
- Balances Most Automotive Wheels
- Single-Spin Dynamic Two-Plane or Static Balancing
- Vertical Wheel Mounting
- Back Cone and Front Cone Mounting
- "No Bolt-Down" Installation
- Scratch Resistant Control Panel
- Easy-to-Read LEDs and Displays
- Automatic Calibration
- Removable Shaft Stud
- Automatic Rim Gauge Return
- Dynamic, Static, and Alloy Operating Modes
- Solid State Motor Controller

Standard Accessories

- Built-in Weight Tray
- 3 Back Cones
- Threaded Stud
- Back Cone Spring
- Hub Nut
- Pressure Drum
- Rim Width Calipers

Optional Accessories

- Combi Adapter for Special Wheels (P/N 309060)
- Light Truck Cone Mounting System (P/N 309067)
- Wheel Weight Pliers (P/N 111515)
- Hood Kit (P/N 110935)

Assembly and Setup

Floor and Space Requirements

Floor must be solid and flat concrete. The balancer does not need to be bolted to the floor in normal service. The balancer may be bolted to the floor with anchor bolts through the three support feet, but will require an alternate electrical connection method. Whether free standing or bolted to the floor, the balancer must stand only on the three support feet attached to the unit.

Sufficient space must be provided above and around the balancer for mounting and demounting wheels.

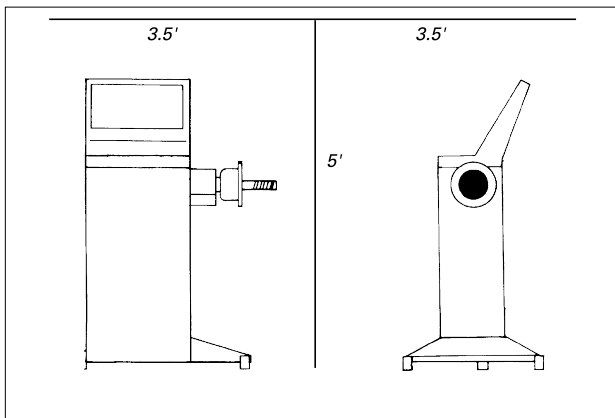

Figure 1 - Space Requirements

Unpacking the Unit

1. Remove the shipping carton from the pallet.
2. Remove all loose parts and accessories packed around the unit.

Remove Balancer from Pallet

3. Remove the shipping bolts that hold the balancer to the pallet.



Do not use the control pod, control pod arm, faceplate, hood or stub shaft to lift the balancer.



Use help to remove the balancer from the pallet. The unit is heavy and the weight is not evenly distributed. Dropping the unit may cause personal injury or equipment damage.

4. Lift the balancer off the pallet and place it in its operating location.
5. Install and tighten the threaded stud into the end of the motor shaft.

Connecting to Power

Consult a licensed electrical contractor for proper connection that meets local electrical codes. Power outlets must be located in a floor raceway or overhead drop if pedestrians or equipment traffic pose a threat of damage to the power cord.

The balancer requires a nominal 115 VAC, 60 Hz, single-phase power supply with a 15 amp fuse or circuit breaker and a three-pin safety outlet.

Electrical outlets must have a solid connection of less than 1 ohm between the ground pin and building ground.



Operation with a defective ground circuit will create a shock hazard for the operator, damage the unit electronics, and will void the warranty.

Power and ground requirements must be verified by the installer or an inspector before connecting the balancer. Failure to observe this precaution may void the warranty.

If the balancer is bolted to the floor, a licensed electrical contractor must be consulted. Most electrical codes require "hard" wiring when the balancer is bolted down.

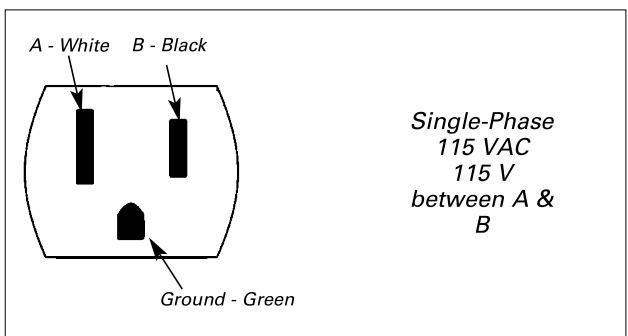

Figure 2 - Electrical Outlet Requirements

Initial Testing

1. Plug the unit into an appropriate power outlet. If the circuit breaker for the outlet is off, turn it on.
2. Turn the balancer on. The power switch is on the back of the unit.

Operating the Balancer

Wheel Mounting

Mount the wheel using the most appropriate mounting method.

A. Back Cone Mounting—Almost all wheels, including aftermarket or mag wheels, can be mounted using one of the back cones. The spring must be used.

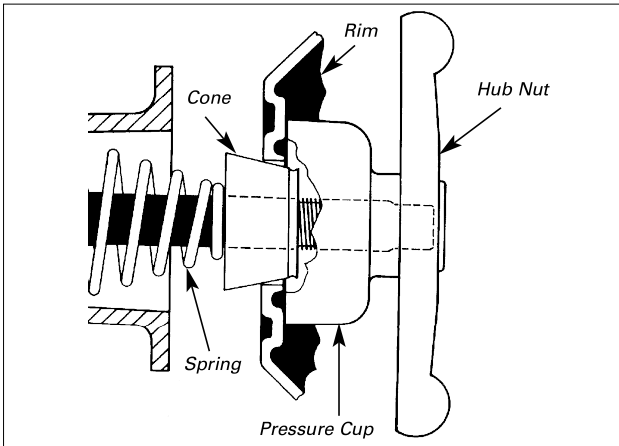

Figure 3 - Back Cone Mounting

1. Place the spring over the threaded stud with the large end inside the faceplate.
2. Determine which cone best fits the wheel center hole. Slide the cone onto the shaft with the large end against the spring.
3. Lift the wheel onto the cone with the inside of the wheel facing the balancer. Center the wheel on the cone.
4. For most wheels, the pressure cup should be snapped onto the hub nut. A nylon spacer ("no mar" ring) can also be used to protect custom wheel finishes.
5. Thread the hub nut onto the shaft, and tighten it against the wheel. The wheel must be forced firmly against the faceplate. The hub nut must engage the threads for at least three full turns.

NOTE: If the hub nut will not tighten completely, use the front cone mounting method.

! WARNING Failure to tighten the hub nut properly may result in the wheel dismounting, causing personal injury and property damage.

B. Front Cone Mounting—Used when the wheel cannot be securely mounted using the back cone method.

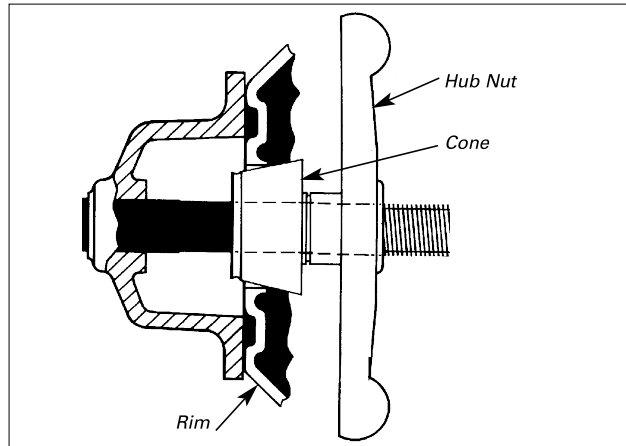

Figure 4 - Front Cone Mounting

1. Determine which cone best fits the wheel center hole.
2. Lift the wheel onto the shaft and push it back against the faceplate.
3. Slide the cone onto the shaft. Lift the wheel and center it on the cone.
4. Thread the hubnut onto the shaft and tighten it against the cone. The hubnut must engage the threads for at least three full turns.

NOTE: If the hub nut will not tighten completely because of a lack of threads, use an additional cone as a spacer between the mounting cone and the hubnut. The wheel must be forced firmly against the faceplate.

! WARNING Failure to tighten the hub nut properly may result in the wheel dismounting, causing personal injury and property damage.

C. Optional Combi Adapter—Can be used for 3, 4, 5, 6, 8, or 10 lug wheels by installing the appropriate number of swivel plates.

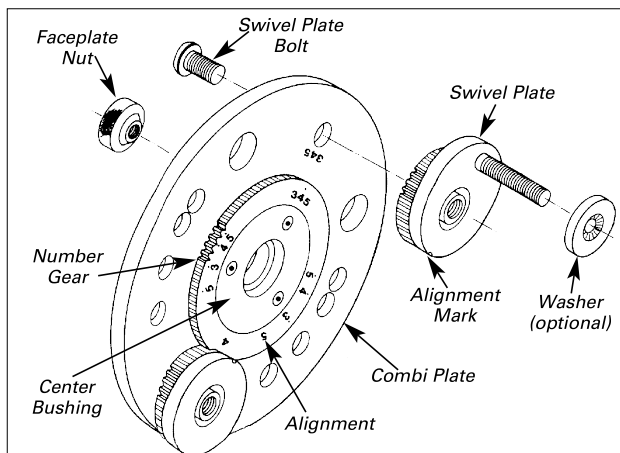

Figure 5 - Combi Adapter (optional)

1. Install a swivel plate over the adapter plate hole marked **3 4 5** and secure with a shoulder bolt. Align the mark on the plate with the dot on the number gear. Do not tighten the bolt.
2. Install swivel plates next to the appropriate numbers (next to the 3's for 3 and 6 lug wheels, the 4's for 4 and 8 lug wheels, and the 5's for 5 and 10 lug wheels). Align the marks on the plates with the dots on the number gear. Secure with a shoulder bolt, but do not tighten.
3. Attach the adapter to the wheel. Rotate the swivel plates until the lugs align with the holes in the wheel.
4. Install the lug nuts and tighten with the adapter wrench. Use a crossing (star) pattern to tighten the lug nuts. Reverse the lug nuts as necessary for proper fit in the lug hole on the wheel.
5. Tighten the swivel plate shoulder bolts with the allen wrench.
6. Align the bolts on the back of the adapter with the holes in the faceplate. Thread a faceplate nut onto each bolt. Hand tighten the nuts while rotating the wheel to ensure proper centering.

WARNING The lug nuts must be centered and threaded at least four full turns. Reverse the lug nuts as required for best fit. Use only the adapter wrench furnished. Do not use air tools or impact wrenches.

D. Optional Light Truck Cone—Allows secure mounting of most light truck wheels.

1. Lift wheel onto threaded shaft. Push it back against the faceplate.
2. Slide cone onto shaft, and center in wheel center hole. The cone lip will help hold the wheel while tightening the hub nut.

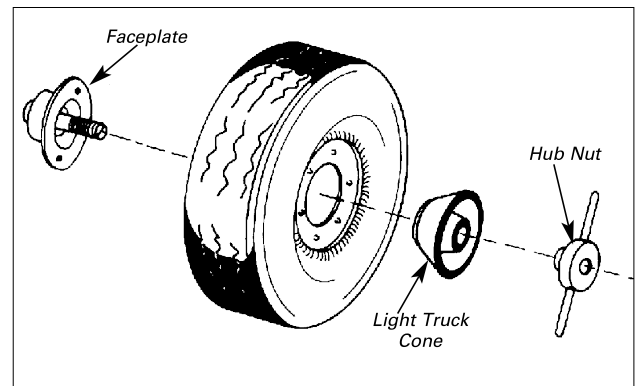

Figure 6 - Light Truck Cone (optional)

3. Thread the hub nut onto the shaft and tighten against the cone completely. The wheel must be forced firmly against the faceplate. The hub nut must engage the threads for at least three full turns.

WARNING Failure to tighten the hub nut properly may result in the wheel dismounting, causing personal injury and property damage.

Selecting Operating Options

Gram/Ounce Toggles unit between weight readings in ounces or grams. Press and hold SHIFT and press GRAM/OUNCE

Round Off Toggles unit between normal mode (0.25-ounce increments) and fine balance mode (0.01-ounce/1-gram increments). Normal mode is 5-gram increments from 0 to 50, and 10-gram increments from 50 to 100. Press and hold SHIFT and press ROUND OFF.

Calibrate Places unit in the calibration mode. Press and hold SHIFT and press CALIBRATE.

Mode Selects the balancing mode. Press MODE until the LED above the desired mode is illuminated.

Entering Wheel Measurements

Wheel measurement data is entered using the wheel measurement keys on the control panel. The top key is for wheel offset (the distance between the edge of the wheel and the balancer, Figure 7). The center key is for rim width (Figure 8). The bottom key is for rim diameter (this measurement is found on the sidewall of the tire).

1. Pull the offset handle out from the upper right side of the balancer and over to the wheel. Rotate the handle until the end touches the second surface of the rim flange.

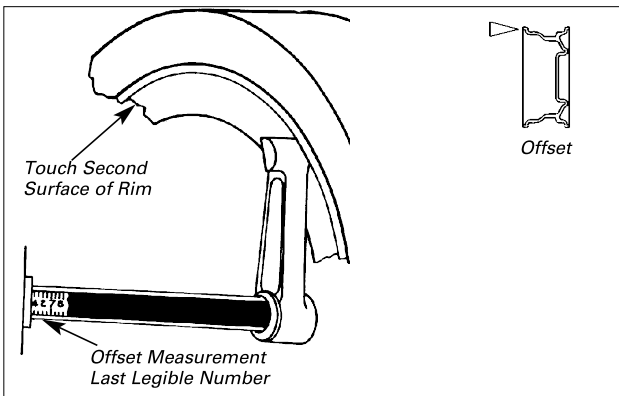
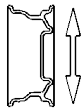

Figure 7 - Measuring Wheel Offset

2. Read the last legible number on the offset handle and enter this number by pressing the offset key then the appropriate numbers on the keypad (for example, press 6 then 5 to enter a measurement of 6.5 inches).

3. Press the diameter key and use the keypad to enter the wheel diameter shown on the tire sidewall.



4. Fit the calipers over the top of the wheel. Touch the ends of the caliper arms to the outside of the rim. On standard wheels, the calipers should touch the vertical rim surface (not the rolled rim flange). On mag wheels, the calipers should touch the flat rim edge.

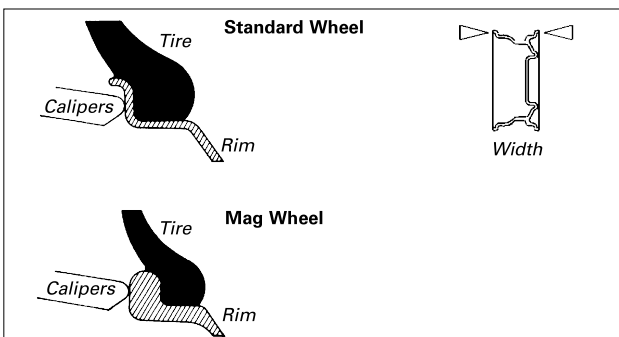

Figure 8 - Measuring Wheel Width with Calipers

5. Read the measurement on the calipers and enter it by pressing the width key and the appropriate numbers on the keypad (for example, press 8 then 5 to enter a wheel width of 8.5 inches)

Balance the Wheel

REMEMBER: This balancer does not have a hood to cover the spinning wheel. Exercise caution when using the balancer. Wear eye protection. Keep bystanders away from operating balancer. Do not attempt to stop the wheel manually - wait for the balancer to brake the wheel to a complete stop before coming in contact with the wheel.

1. Remove any weights from the wheel. Press START. The balancer will spin and stop automatically.

To use the fine balance mode (0.01-ounce increments) press and hold SHIFT and press ROUND OFF.

2. Wait for the wheel to stop completely.

As the wheel brakes to a stop, weight measurements will appear in the weight displays on the control panel. The left display is for the left plane of the wheel, and the right is for the right plane.

Next to each weight display is the weight positioning lights. The two LEDs in the middle of the positioning lights will blink alternately to indicate proper weight position. The LEDs above and below will indicate which way to rotate the wheel to reach the weight position.

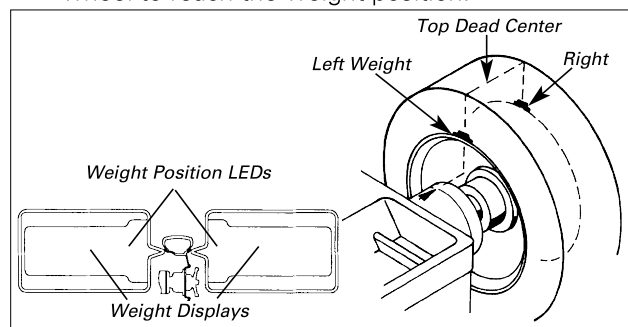

Figure 9 - Weight Positioning

3. Rotate the wheel until the left weight position LEDs blink. Attach the specified weight size at top dead center.
4. Rotate the wheel until the right weight position LEDs blink. Attach the specified weight size at top dead center.

NOTE: The more accurate you are in selecting the exact weight and position; the more often you will balance in one spin.

5. Respin the wheel. Your weight readings should now be 0.00 (in normal mode).
6. Remove the wheel. If you are balancing another wheel identical to this first one, you do not need to remeasure the wheel or reset the wheel measurements. Mount the tire, remove any weights, and press START.

Alloy Balancing

Specialty wheels, balanced with adhesive backed weights hidden on the inner surface of the wheel, should be balanced in the ALLOY mode. When the ALLOY mode is selected, the computer automatically calculates the outer weight position as the middle of the rim width. The inner weight position is under the inner flange of the wheel (Figure 10). All alloy wheel dimensions are measured and entered into the balancer in the same manner as described in the Entering Wheel Measurements section.

CAUTION Weights must be attached securely to wheel surfaces cleaned according to weight manufacturer's recommendation. Failure to do so may cause weight to come loose during a spin, resulting in personal injury.

Two Adhesive Weights, Outside Weight Visible

1. Mount wheel and remove weights.
2. Press Mode key until the ALLOY LED is illuminated.
3. Enter wheel offset, diameter and rim width measurements.
4. Press START. Wait for readings to appear and wheel to stop.
5. Rotate wheel until left weight position lights

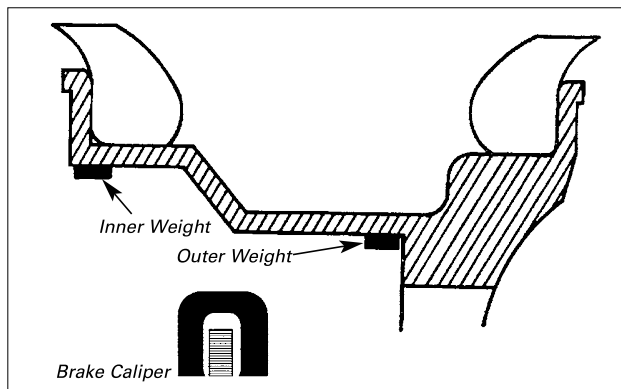

blink.

Figure 10 - Two Adhesive Weights, Right Weight Visible

6. Attach the specified weight to the left plane of the wheel.
7. Rotate wheel until the right weight position lights blink.
8. Attach the specified weight to the right plane of the wheel.
9. Respin the wheel. Repeat Steps 5 through 8 until readings are 0.00.

NOTE: It is recommended that adhesive weights are covered with aluminum foil or duct tape to keep the

weight clean and securely attached to the wheel.

IMPORTANT: After placing the balanced wheel on the vehicle, check for adequate clearance between the weight and the brake caliper.

Static Balancing

Static balanced wheels may wobble if the imbalance mass is large enough and off the centerline of the rim width. Wobble caused by an off center imbalance can be corrected only by dynamic balancing of the wheel.

When the STATIC mode is selected, the computer automatically calculates the middle of the rim width as the proper weight position (Figure 11).

All wheel dimensions are measured and entered into the balancer in the same manner as described in the Entering Wheel Measurements section.

1. Press Mode key until the STATIC LED is illuminated.
2. Press START. Wait for the reading to appear and the wheel to stop. The weight displayed is the weight required to balance the wheel (within 0.25-ounce).
3. Rotate the wheel until the weight position lights blink.

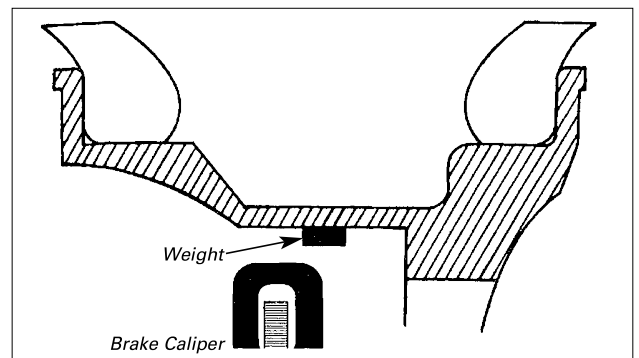

4. Attach the specified weight to the center of the wheel.

Figure 11 - Static Balance Weight Position

NOTE: It is recommended that adhesive weights are covered with aluminum foil or duct tape to keep the weight clean and securely attached to the wheel.

IMPORTANT: After placing the balanced wheel on the vehicle, check for adequate clearance between the weight and the brake caliper.

NOTE: If using static balancing mode with clip-on weights, add 1.5-inches to the rim diameter to compensate for weight placement.

Maintenance and Service



Do not use solvents, which leave an oily residue.



Never use compressed air or a water hose to clean any part of your balancer.

Preventative Maintenance

Daily Clean shaft and faceplate with a vaporizing solvent. Cones, hub nut, and other mounting hardware should be checked and cleaned.

Weekly Thoroughly clean entire unit. Remove all used weights, tools, and parts from under and around balancer. Perform a calibration check. Make calibration adjustments if required.

NOTE: Before each balancing operation, make sure that the back face of the wheel is clean. Use a wire brush to clean the back face of the wheel if needed.

Service

If service should ever be required for your balancer, contact the Service Department at (800) 688-6359. Have your model and serial number ready.

Calibration Check Procedure

This procedure can be performed by the operator to ensure the balancer is operating correctly and properly calibrated. The only purpose of calibration is to fine-tune the balancer to yield single-spin balancing.

Use the fine balance mode during this procedure (press and hold SHIFT and press ROUND OFF).

If the balancer fails to produce the results outlined in this procedure, perform a calibration adjustment.

1. Use normal mounting procedures to mount a standard domestic 14 by 6.5-inch wheel with a standard tire. Do not use a wheel that is bent or misaligned. The center hole must be free of nicks or burrs.
2. Enter the offset, rim width, and wheel diameter measurements into the balancer.
3. Balance the wheel. Remember to use the fine balance mode. Proceed to Step 4 when your weight displays read 0.10 ounces or less (you may need to trim weights to accomplish this).
4. Attach a 4-ounce test weight to the right side of the rim.
5. Spin the wheel. The reading in the right weight display should be between 3.85 and 4.15.

6. Rotate the wheel until the outer weight positioning lights flash. The test weight should be in the 6 o'clock position. The inner weight reading should be 0.15 ounces or less (this figure is the result of the interference between the two balancing planes).
7. Repeat Steps 4, 5, and 6 with the test weight on the left side of the rim.

Calibration Procedure

1. Mount a wheel that best represents the tire/wheel size most commonly balanced on this unit. In most cases, this will be a 14-inch diameter by 6-inch wide wheel. Remember to remove any weights attached to the wheel.
2. Enter the A (offset), W (width), and D (diameter) measurements.

NOTE: It is important that you are accurate in entering these measurements. Inaccurate measurements will adversely affect your calibration.

3. Press and hold SHIFT and press CALIBRATE. "CAL 0" will appear in the displays to indicate Calibration Mode.
4. Press START to spin the wheel. Wait for the wheel to brake to a stop.
5. The balancer will indicate a 4-ounce weight (100 grams in grams mode). Rotate the wheel until the right weight positioning lights blink. Attach the weight at top dead center on the right plane.

REMEMBER: The more accurate you are in locating the weight on the wheel, the more accurate your calibration.

6. Press START to respin the wheel. When the wheel brakes to a stop, calibration is complete and the balancer will automatically exit the Calibration Mode.

Troubleshooting

Special Problems

Customers will occasionally complain of vibration on the car after balancing. Some possible causes are:

1. Beads are improperly seated. Check bead seating and inflation pressure before balancing.
2. Stiffness variations in radial belts.
3. Tire or wheel out of round, wheel bent, or not running true. Visually check runout of wheel and tire during balance spin. Re-check mounting. Replace wheel or tire as necessary.
4. Suspension wear, misalignment, or loose vehicle components.
5. Wheels not correctly centered because of damaged hub, damaged or worn center hole, worn bolt circle holes, or imprecise original design. Check wheel runout before balance spin and again on the vehicle after re-mounting.
6. Sensitive suspension. Use the fine balance mode.

Operator Complaints

1. Balancer uses too many weights or several spins to balance.

Remedy: Re-check rim dimensions and correct balancer settings as necessary.

Remedy: Position weights at exactly top dead center when weight positioning lights flash.

Remedy: Calibrate balancer.

2. Weight or position readings fluctuate.

Remedy: Check cone and hub nut for slippage. Tighten as needed.

Remedy: Verify that the balancer is sitting solidly on its three mounting feet. Verify that the floor is flat and stable, that there are no tools or weights caught between the balancer and the floor.

Parts Identification

ITEM	PART NO.	QTY.	DESCRIPTION	ITEM	PART NO.	QTY.	DESCRIPTION
1	110936	1	Chassis	43	143847	1	Plug, 3/4
2	143862	1	Pad, Anti-Skid	44	308817	1	Shutter, Encoder
3	308860	1	Cover, Hand Hole	45	110902	1	Encoder Assembly
4	106301	10	Screw, 1/4 x 3/4 HH Self-Tap	46	308859	1	Cover, Encoder
5	106303	6	Nut, 3/8 Whiz Lock	47	301072	3	Washer, Lock #6
6	111036	3	Piezo Assembly	48	301063	3	Screw, 6-32 x 1/2
7	301017	3	Ball, Steel, 1/2" Dia., Piezo	49	301016	1	Bolt, Shoulder, 3/8 x 3/8 Lg.
8	307022	2	Bracket, Capacitor	50	301035	4	Nut, 3/8-16 Nyloc
	110558	1	Bracket Capacitor	51	308036	4	Ret, Piezo Spring
9	111815	1	Capacitor Assembly, 1P 110V	52	307008	4	Spring, Piezo
	111814	1	Capacitor Assembly, 1P 220V	53	111074	1	Cradle, Motor
10	112208	4	Standoff, 8-32 male, 3/8 high	54	120325	2	Screw, 5/16-18 x 1 Whiz Lock
11	301094	2	Screw, 8-32 x 3/4 Flat Head	55	301121	4	Washer, 1/2
12	301084	4	Nut, #8-32 Kep	56	308808	1	Flex Plate
14	106302	10	Screw, 3/8 Whiz Lock	57	301033	4	Nut 3/8-16 Jam
15	111218	1	Breaker, 2 Amp	58	108727	4	Stud, 3/8-16 x 6.75
16	301067	12	Screw, #6-32 Phillips PHM, Patch Lock	60	143845	1	Gasket, motor
17	305802	1	Switch, On-Off	61	111645	1	Scale, Distance Gauge
18	110897	1	Power Panel	62	143808	1	Assembly, Distance Gauge
19	106304	2	Skin Fastener, Tinnerman	63	111818	1	Harness, Power Panel
20	111793	1	PCB Assembly	64	110903	1	Harness, Piezo
21	110579	1	Touch Panel	65	111066-5	1	Wire Assembly, 22 AWG Brown
22	308878	1	Weight Tray	66	111802	1	Wire Assembly Switch to M/C Board
23	308017	1	Button, Rubber, Black	67	111803	1	Wire Assembly Transformer to M/C Board
25	306806	1	Transformer	68	111805-1	1	Wire Assembly PCB to M/C Board
26	111542	6	Screw, #8-32 x 1/2 Phillips Pan Head	69	111819	1	Wire Assembly Interlock Switch
27	111879	1	Motor Control Board	70	143796	1	Power Cord, 110V Plug
28	143956	2	Retainer, Bushing		143796-2	1	Power Cord, 1P 220V
29	110168	1	Stop, Distance Gauge	71	6058	1	Strain Relief
30	308023	1	Spring, Distance Gauge	72	308550	1	Arm, Distance Gauge
31	107635	2	Washer, 3/8" Flat	74	308535	1	Spacer
32	301142	1	Washer, Lock	75	308074	2	Bushing, Rear
33	104755	4	Nut, Tinnerman	76	104200	1	Washer, Int. Lock 3/8 ID
34	110543	1	Hub Nut	77	111136	2	Screw, 1/4 x 1/2 HH Self Tap
35	110542	1	Pressure Drum, Small				
36	308105	1	Ring, No-Mar				
37	110410	1	Cone, Small				
38	110411	1	Cone, Medium				
39	110412	1	Cone, Large				
40	308820	1	Spring, Cone Back				
41	308171	1	Stub Shaft				
42	110671-4	1	Motor, 110V				
	110671-5	1	Motor, 220V				

