

COATS®

IBS 2000

Interactive Balancing System

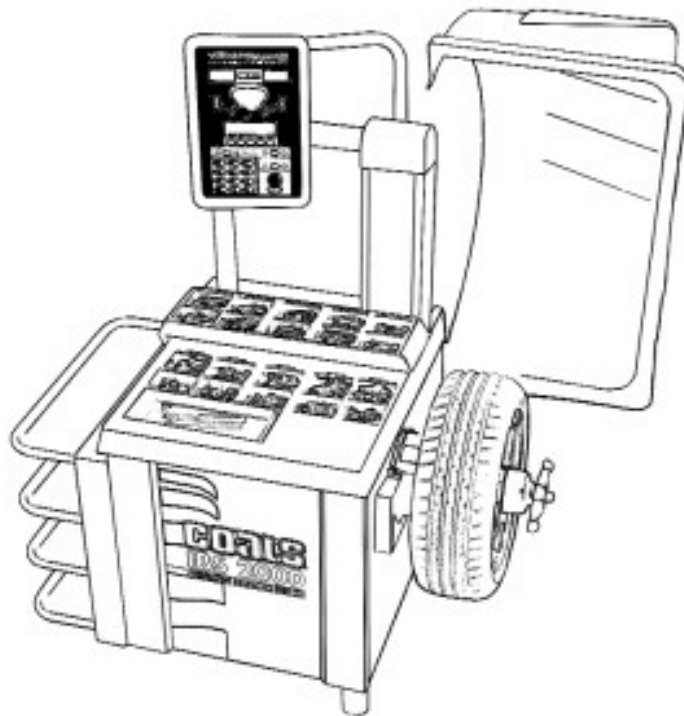

**Service Manual and
Troubleshooting Guide
*with Parts Identification***

***HENNESSY* INDUSTRIES, INC.**

P.O. Box 3002, 1601 J. P. Hennessy Drive, LaVergne, TN USA 37086 615/641-7533 800/688-6359

HENNESSY INDUSTRIES INC. Manufacturer of AMMCO®, COATS® and BADA® Automotive Service Equipment and Tools.

Manual Part No.: 9112388

Revision: 12/00 rev. 1

Direct Drive

Contents

Introduction	1	Spin and Stop Diagram	21
Safety Notes	1	Motor Controller Diagram	22
Principal of Operation	1	Optical Encoder Checking Procedure	23
Component Functions & Benefits	2	Rotary Shutter Checking Procedure	23
2000 Balancer Simplified Block Diagram	3	Piezo Output Test	23
Servicing	4	Piezo Crystal Checking Procedure	24
Equipment Needed	4	Balancer Display Diagnostics	24
Voltage & Phase Checking Procedure	4	Serial Loopback Test	24
Installation Instructions		Replacement Procedures for Model	
Unpacking and Setup	5	IBS 2000 Balancer	25-30
Hood Installation	5	Display Board Assembly Replacement	25
Faceplate Assembly Installation	5	E-Prom Replacement	25
Preliminary Inspection	5	LCD Board Replacement	26
Functional Checks		Start Switch Replacement	26
Operational Check	6	Touch Panel Replacement	26
Calibration Procedures		Hood Magnet Replacement	26
Balancer Calibration	6 - 7	Hood Switch Replacement	26
Plane Separation (Accuracy Check)	7	Safety Interlock Switch Replacement	26
Optimizing A (Distance Gauge Tape Placement)	7	On/Off Switch Replacement	26 - 27
Arm Calibration	7 - 8	Circuit Breaker Replacement	27
Accuracy Problems	8	Power Supply Board Replacement	27
Rotation Check	8	Motor Controller Board Replacement	27
Cycle Counters	8	CPU Board Replacement	27
Total Accuracy Verification (TVA)	9	Fan Motor Assembly Replacement	28
Error Codes		Rotary Shutter Replacement	28
LED Error Codes	9	Optical Encoder Assembly Replacement	28
LCD Error Codes	9 - 10	Drive Motor Assembly Replacement	28-29
Troubleshooting Flow Charts		Faceplate & Shaft Assembly Replacement	29
Pre-diagnostic Check	11	Piezo Assembly Replacement	29
Wheel Does Not Spin	12	Capacitor Assembly Replacement	30
Wheel Does Not Stop	13	Signal Harness Replacement	30
No Communications	14	A/D Arm Repair and Replacement	30-31
Keypad Problems	15	A/D Arm Replacement	56
No LCD Display	16	A Gear Assembly Replacement	57
LCD Contrast Won't Adjust	17	Small D Gear Assembly Replacement	57
No LCD Back-Light	18	Large D Gear Replacement	58
No LED Display	19	A/D Arm Subassembly Replacement	58
EE ERR	19	Parts Identification	32-35
A & D Arm Problems	20	IBS 2000 Parts Illustration	32-33
Diagnostic Procedures		IBS 2000 Wiring Diagrams	36-39
Motor and Motor Controller Checking Procedure	21		

IMPORTANT SAFETY INSTRUCTIONS

READ ALL INSTRUCTIONS

1. Eye and face protection recommendations:
“Protective eye and face equipment is required to be used where there is a reasonable probability of injury that can be prevented by the use of such equipment.” O.S.H.A. 1910.133(a) Protective goggles, safety glasses, or a face shield must be provided by the owner and worn by the operator of the equipment. Care should be taken to see that all eye and face safety precautions are followed by the operator. **ALWAYS WEAR SAFETY GLASSES.** Everyday glasses only have impact resistant lenses, they are not safety glasses.
2. Do not disable hood safety interlock system, or in any way shortcut safety controls and operations.
3. Be sure that wheels are mounted properly, the hub nut engages the arbor for not less than four (4) turns, and the hub nut is firmly tightened before spinning the wheel.
4. Read and understand this manual before operating. Abuse and misuse will shorten the functional life.
5. Be sure the balancer is properly connected to the power supply and electrically grounded.
6. Do not operate equipment with a damaged cord or if the equipment has been dropped or damaged – until it has been examined by a qualified serviceman.
7. Do not let cord hang over edge of table, bench, or counter or come in contact with hot manifolds or moving fan blades.
8. If an extension cord is necessary, a cord with a current rating equal to or more than that of the equipment should be used. Cords rated for less current than the equipment may overheat. Care should be taken to arrange the cord so that it will not be tripped over or pulled.
9. Keep guards and safety features in place and in working order.
10. Wear proper clothing. Safety toe, non-slip footwear and protective hair covering to contain hair is recommended. Do not wear jewelry, loose clothing, neckties, or gloves when operating the balancer.
11. Keep work area clean and well lighted. Cluttered and/or dark areas invite accidents.
12. Avoid dangerous environments. Do not use power tools or electrical equipment in damp or wet locations, or expose them to rain.
13. Avoid unintentional starting. Be sure the balancer is turned off before servicing.
14. Disconnect the balancer before servicing.
15. Use only manufacturer’s recommended accessories. Improper accessories may result in personal injury or property damage.
16. Repair or replace any part that is damaged or worn and that may cause unsafe balancer operation. Do not operate damaged equipment until it has been examined by a qualified service technician.
17. Never overload or stand on the balancer.
18. Do not allow untrained persons to operate machinery.
19. To reduce the risk of fire, do not operate equipment in the vicinity of open containers or flammable liquids (gasoline).
20. Adequate ventilation should be provided when working on operating internal combustion engines.
21. Keep hair, loose clothing, fingers, and all parts of body away from moving parts.
22. Use equipment only as described in this manual.
23. Use only manufacturer’s recommended attachments.

SAVE THESE INSTRUCTIONS

Direct Drive

Introduction

This service manual contains the functional checks, troubleshooting, adjustment, and part replacement instructions for COATS® Model IBS 2000 Wheel Balancer. Exploded views, illustrations, and an indexed parts list facilitate parts location, ordering, and replacement. All adjustments and replacements can be rendered with mechanic's or electrician's tools.

Safety Notes

HIGH VOLTAGES, HIGH TORQUE MOTORS, and HIGH SPEED ROTATING WHEELS are present in COATS wheel balancers. Follow the SAFETY RULES when servicing any balancer:

- 1.** DISCONNECT BALANCER from power source before starting any parts replacement or internal adjustment.
- 2.** LOWER GUARD HOOD before starting cycle.
- 3.** DO NOT WEAR LOOSE CLOTHING, such as neckties, while servicing the balancer.
- 4.** LONG HAIR should be worn UP, or under a HAT.
- 5.** WHEELS MUST BE MOUNTED PROPERLY:
 - Cones must be centered in the wheel before tightening.
 - The wheel must be forced up firmly against the faceplate.
 - The hub nut must be engaged by a minimum of four (4) full threads.
 - Tighten the hub nut rotating the wheel and striking a spoke of the hub nut with the heel of the hand.

Caution! Failure to tighten the hub nut could result in serious injury!

Principle Of Operation

The model IBS 2000 Wheel Balancer utilizes the principle that any rigid body rotating about an axis through the body can be balanced using weights mounted in two planes. In this case the rigid body is an automobile wheel and tire assembly which is mounted precisely on center and rotated to measure the imbalance forces in two planes. As the wheel rotates, any imbalance in the wheel results in radial outward forces on the wheel and the distances from the voltages produced by the piezo sensors.

With the forces known at the planes of the piezos the imbalance forces at the wheel planes can be calculated by using the distance from the force transducer planes to the wheel correction planes. These wheel imbalance forces are displayed for the wheel planes selected during the setup procedure so the correction weights can be added. A check spin is recommended to assure that the wheel is in fact balanced. For the measurement to be accurate:

- 1)** the wheel must be mounted precisely on center
- 2)** the wheel plane parameters must be entered accurately
- 3)** the distance and diameter arm and the balancer must be calibrated carefully.

The Model IBS 2000 Balancer uses several modules to control the balancing sequence. The COATS® Direct Drive system includes the following primary elements:

- Direct Drive Motor and Shaft Assembly
- Motor Controller Printed Circuit Board
- CPU Printed Circuit Board Assembly
- Touch Panel
- Display Printed Circuit Board
- LCD Display

The balancing operation is started by mounting the wheel and then selecting the planes for the desired placement of wheel weights from the touch panel. The wheel parameters are then entered for distance, width, and diameters appropriate for the correction planes selected.

The measurement is started by pushing the START switch or lowering the hood. The display PCB responds to the START command by sending the command to the CPU which begins the measurement cycle. The CPU turns the SPIN SSR ON which powers the motor in the forward direction. As soon as the motor reaches the measurement speed the power is removed and the wheel coasts while the signal from the piezos is being measured. When the measurement is completed the CPU turns on the BRAKE SSR which reverses the motor and brings the wheel to a stop. The WEIGHT and POSITION readings for each plane are sent from the CPU to the Display PCB where they are displayed. The correction planes can be changed if desired and the displays are updated automatically.

Direct Drive

Component Functions & Benefits

Motor Controller

Function: Controls the AC power for the spin and brake cycles of the motor.

Benefit: Solid State Relay (SSR) replaces mechanical contactor.

- Eliminates contact arcing, RF interference.
- Eliminates mechanical problems.
- Eliminates multiple wire connections.

Also: AC power is routed through this board for the:

- On/Off Switch
- Cooling Fan
- Power Supply PCB
- Phase Converter



The SSR is electrically HOT any time the unit is plugged into the wall!

Power Supply

Function: Supplies regulated voltage to operate the electronics used on the PCB's.

- +12 vdc (VDD)
- 12 vdc (VEE)
- +5 vdc (VBB)

Benefit: Separate PCB reduces board replacement cost.

Also: Input voltage is AC line voltage routed through the Motor Controller PCB

Display Board*

Function: Controls the lighting of all LED's.

Benefit: Separate PCB reduces board replacement cost.

Also: Manual start switch connects to this PCB.

Power for the LCD back light and control signals come from this PCB.

Has contrast pot adjustment.

Has +5 vcc (VCC) regulator

LCD*

Function: Displays operator interactive instructions.

Benefit: Makes the unit easier to operate and calibrate.

Single PCB replacement.

Proven technology.

Main CPU*

Function: Receives data from all input devices (piezos, encoder, A/D pots, hoodswitch).

Processes the information and sends it to the appropriate PCB.

Benefit: Separate PCB reduces board replacement cost. Latest microprocessor design.

Also: Has +5 vdc (VCC) regulator

Phase Converter

Function: Allows three phase motor to be used on single phase power.

Benefit: Allows the use of three phase motors in all balancers.

Easy to convert from one phase to three phase. Uses same capacitor as 1050 but different connectors.

Fan

Function: Keeps the motor from overheating.

Benefit: Allows us to use direct drive motors.

Also: These fans are 220v (950/1050 has 110v).

Piezos

Function: Measures the weight imbalance in a wheel.

Benefit: Proven Technology, reliable.

Also: Same as in the 1050 but different connector and isolated.

Encoder

Function: Aids in measuring the imbalance location, in a wheel.

Determines rotational speed and direction.

Benefit: Proven technology.

Same as a 1050 but different connector.

Motor

Function: Used for mounting and rotating the wheel.

Benefit: Direct drive, no need to balance.

No belts, less noise interference.

Replaceable faceplate and shaft assembly.

Optional 40mm faceplate and shaft assembly.

*Indicates electronic components which carry a three year warranty.

Direct Drive

2000 Balancer Simplified Block Diagram

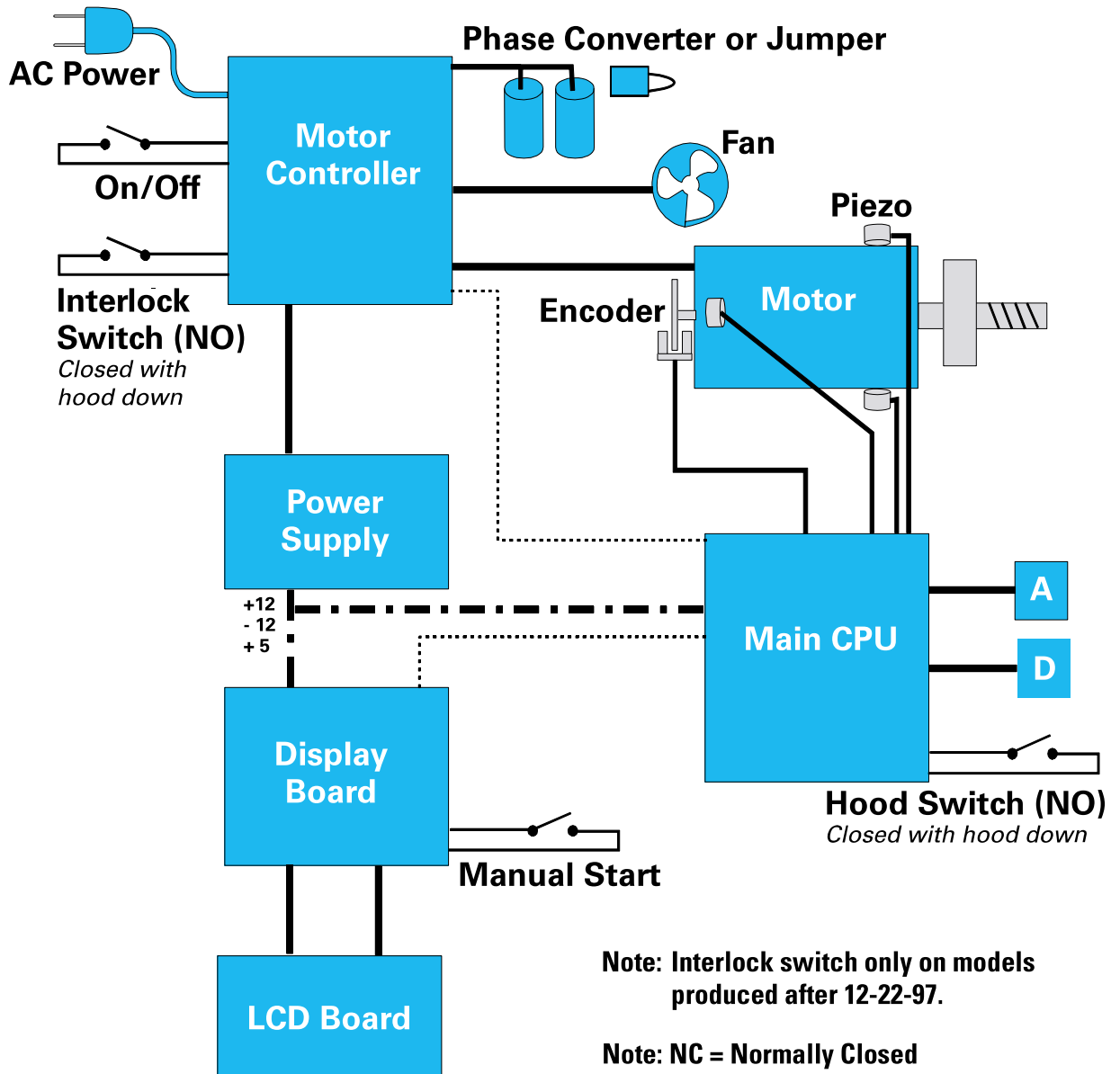

Note: Interlock switch only on models produced after 12-22-97.

Note: NC = Normally Closed
NO = Normally Open

The normal position is when the magnet is next to the switch.

Direct Drive

Servicing

Service should be performed only by a factory trained COATS® Service Technician. The troubleshooting and service procedures in this manual are arranged to allow rapid and thorough service. The steps are:

- Preliminary Inspection
- Functional Checks
- Repair Of Failure
- Replacement Or Adjustment
- Functional Checks

Identification of replacement parts required can be accomplished by using the pictorial breakdown and index in this manual. It is important that the FUNCTIONAL CHECKS be performed IN SEQUENCE and the PROBLEM ISOLATED. If an adjustment is made, the entire FUNCTIONAL CHECK must be performed SUCCESSFULLY before the balancer can be considered available for service.

Equipment Needed

1. AC / DC - Volt / Ohm meter (DVM).
2. Test Wheel - Domestic 14" x 6" steel wheel with a center hole suitable for mounting with a back cone. A new 195/70/14 tire properly mounted and inflated, balanced to within 0.02 ounces should be part of this wheel assembly. The lateral run out of this wheel should be less than 1/8". Modeling clay and 4 oz. test weight.
3. Flat and Phillips screw drivers, and dead blow hammer.
4. Tester for phone cables and jacks. (Modapt adaptor, Contact East Part #118-785, call 1-800-225-5334 to order.)
5. Thread locking anaerobic (Loctite 242 or equivalent). Retaining compound (Loctite 601 or equivalent).

6. Torque Wrench & a 5/16 X 6" hex socket for the torque wrench.

7. Small Allen wrenches, pot adjusting tools, & a 3/8" nut driver.

8. Chip extractor tool, Ammco part # 29977.

9. A dial indicator (runout gauge) , Ammco part # 2850, or 29752.

10. Sockets: 3/8, 7/16, 3/4, 1/2, 9/16 inch, a speed handle, or ratchet.

11. A drill and 1/8" drill bits, pop rivet gun, and 1/8" rivets.

12. A 7/16" - 3/8" box end wrench, and cutters for banding.

Voltage & Phase Checking Procedure

1. Unplug the Balancer from the power source.
 2. Perform all voltage checks shown in the appropriate diagram and chart at the power receptacle. If one or all voltage measurements is faulty be sure to check the status of the circuit breakers that supply the Balancer.
 3. Check from one of the power terminals to the ground terminal to verify a ground is present. The voltage measurement should be approximately one half of the available voltage (i.e. 220V should read 110V).
- Note: If any faults are found in the above procedure, it is the responsibility of the owner. COATS® authorized service personnel are not responsible for wiring within the building.**
4. Plug the balancer into a power source.
 5. Use an Ohmmeter to check the resistance between the frame of the balancer and the building ground. The resistance should be less than 1 ohm. If the resistance measurement is greater than one (1) ohm, check the power cord plug and frame connection for proper contact.

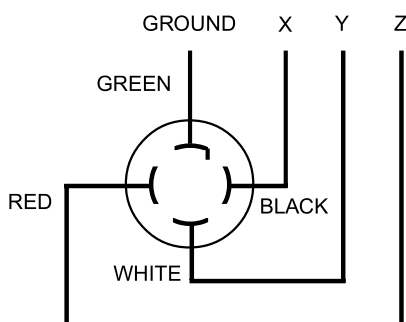

THREE PHASE VOLTAGE REQUIREMENTS / INFORMATION

	208V/220V/230V	380V	460V
X - Y	195-250	370-420	420-480
X - Z	195-250	370-420	420-480
Y - Z	195-250	370-420	420-480
Plug Installed	Hubbell 2421	Hubbell 2431	
Required Mating Outlet	Hubbell 2420 or Equivalent	Hubbell 2430 or Equivalent	

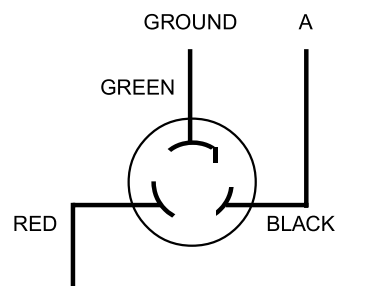

SINGLE PHASE VOLTAGE REQUIREMENTS/ INFORMATION

	208V/220V/230V
A - B	195 - 250
Plug Installed	Hubbell 5466-C
Required Mating Outlet	Hubbell 5462 or Equivalent

Direct Drive

Installation Instructions

Unpacking and Setup

1. Remove the staples from around the bottom of the carton, and carefully remove the box.

2. Unstrap and remove the hood, accessory box and all packing.

3. Inspect the unit and all accessories for damage.

Note: Report any damaged or missing parts to the Hennessy Order Entry Department immediately. CALL 1-800-688-6359.

4. Remove the three (3) hold down brackets from the machine & pallet. Do not discard. Retain for the customer, he may wish to use them to bolt his unit to the floor.

5. Remove the balancer from the pallet.

Caution! This unit is very heavy and will require assistance for lifting and moving. DO NOT DROP! DO NOT LIFT BY THE MOTOR SHAFT!

Note: If there is a bolt on the back of the hood support bracket, near the bottom right side of the accessory column, REMOVE IT. It will interfere with the hood installation.

6. Remove the Allen head bolt at the bottom of the pod tube, and retain for later use.

7. Loosen the four (4) bolts on the tube brackets, and slide the tube into position with the locating ring.

8. Install the Allen head bolt.

Caution! Be careful not to damage the wire harness.

9. "Snug" the bolts on the tube brackets, but do not overtighten. The Pod should swing with some resistance, but not loosely.

10. Push the harness into the pod tube, and install the plastic cover.

11. Check the power plug with the phase of the machine on the serial tag. Make sure the plug matches the customers outlet.

Hood Installation

1. Install the hood magnets (two sets, for hood switch and interlock switch to the holes on the hood cam. The nylon washer goes between the magnets and the cam. **Do not over tighten**, or the magnets will break.

2. Slide one of the nylon bushings onto the hood bar, flange to the cam.

3. Lift the hood up and slide the bar into the machine, you may need assistance. Let it rest on the hood stop.

4. Slide the other nylon bushing into position from the inside, slide on the washer and the retaining ring.

5. Attach the hood spring. The straight end goes at the bottom of the machine the hook end into the hood.

Note: The hood must be in the raised position, to install the spring. For Safety, you should have someone support it.

Faceplate Assembly Installation

1. Remove the hub nut and cones from the threaded shaft. Store on the accessory pegs.

2. Clean the contacting surfaces of both the motor shaft and faceplate assembly with a soft cloth. Note the witness marks on both, these should be aligned before installing.

3. Slide the 6 inch socket head bolt (included in the parts bag) and the (5/16 X 6") Allen wrench extension into the faceplate assembly. **Hand tighten.**

4. Attach the torque wrench. Hold the faceplate with one hand to keep from turning. Tighten to 20 ft/lb.

Caution! DO NOT OVER TIGHTEN. Over tightening will result in damage to the motor shaft.

5. Dial indicate the faceplate and shaft assembly there should be not more than .002-inch on the faceplate and not more than .001 runout on the shaft. If so refer to Faceplate Assembly Replacement procedures.

Preliminary Inspection

1. The floor should be a solid, flat surface that does not allow the balancer legs to set into a recess in the floor or sink into the floor itself.

2. The balancer should sit on all three (3) legs. Make sure the legs have not filled with dirt, wheel weights, or any foreign matter that may prevent a leg from making contact with the floor.

3. Inspect all cones, hub nut, pressure cup, motor shaft, faceplate, and shaft assembly for damage. Missing parts or accessories should be reported immediately to Hennessy Order Entry Department at 1-800-688-6359.

4. Check the power supply to the balancer. Refer to the VOLTAGE CHECKING PROCEDURE.

5. Check the operation of the cooling fan on the drive motor. The fan should run as soon as the balancer is turned on. If not, check the breaker on the Accessory Column of the balancer. If it has tripped, reset it. If it will not reset refer to the PRECHECK procedure.

6. Check the rotation of the motor. Press START, does the motor spin clockwise? If not, for a 3ph Balancer - switch any two of the hot leads on the plug.

Direct Drive

Functional Checks

Operational Check

1. Turn the power switch ON. The display should read as follows:

LCD: Grams/Ounces - Defaults to last selection.
Mode - Round off ON
Hood Start - Hood Start ON
A, W, D - 0.00
PRESS ANY KEY TO CONTINUE

If the LCD Does Not Light, see flow chart for No LCD Display.

LED: Weight Displays - 0.00
Mode - Dynamic
Operator - A

If the LED's do not light, see flow chart for No LED Display.

2. Mount your test wheel (described in EQUIPMENT NEEDED) on the balancer.

3. Enter the wheel parameter data using the automatic A/D arm.

Note: If you do not get proper wheel parameters from the A/D Arm, check the A&D potentiometers found in the CALIBRATION MENU, follow the procedures for Arm calibration. If the A/D arm has failed, you may manually enter the data. If the Keypad does not work, see TOUCH PANEL PROBLEMS.

4. If the balancer is in round off mode, go to the SET UP menu, select NON-ROUND OFF and press enter.

5. Go to the SET UP menu, select the desired weight mode (this procedure may be performed in either mode) GRAM or OUNCE and press enter.

6. Install a 4 oz./100 gram weight on the outer rim of the test wheel.

7. Choose the DYNAMIC balancing mode.

8. Lower the guard hood. (if HOOD START is on, the balancer will automatically cycle at this time, if not see step 9).

9. Push the START button. The machine should now cycle. If the machine does not cycle, see BALANCER DOES NOT SPIN.

10. The balancer should come up to speed, coast for several revolutions, and then brake to a stop. If the machine fails to brake and continues to coast, see BALANCER DOES NOT STOP.

11. The balancer should now have weight values and position lights displayed.

12. Rotate the wheel so the top and bottom position LED's for the outside (right) plane are flashing.

13. Note the position of the 4 oz. weight and the weight readings for both planes.

14. Now rotate the wheel so the center LED for the outer (right) plane is flashing. The 4 oz. weight should now be at (or near) the 6:00 position.

15. Perform five (5) cycles and note the positions and weight readings after each spin. The weight readings should repeat within .2 oz. and the position within + 1/2 inch. If they do not, see ACCURACY PROBLEMS.

Note: If the customer has problems with a specific wheel assembly only, make sure there is no water or debris inside the assembly.

Calibration Procedures

Balancer Calibration

1. Turn the power switch ON.

2. Mount your test wheel to the machine.

3. Enter the wheel parameters using the A/D arm and the rim calipers.

4. If the machine is in ROUND OFF mode go to the SET UP menu and select NON-ROUND OFF.

5. If the machine is not in OUNCE mode go to the SET UP menu and select OUNCES.

Note: This procedure can be performed using GRAMS or OUNCES. If using GRAMS, refer to a conversion chart for weight conversions.

6. Go to the MAIN menu and select CALIBRATE BALANCER to enter the calibration mode. The status bar should now read CAL 0. Follow the instructions on the display.

7. Push the START button, or lower the hood. The machine should now cycle. This cycle is referred to as the zero spin cycle.

8. The balancer should come up to speed, coast for several revolutions, and then brake to a stop.

9. The status bar should now read CAL 1. Follow the instructions on the display.

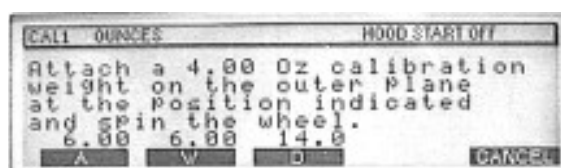

Direct Drive

10. Position the wheel so the display for the center position LED on the outside (right) plane is flashing.

11. Place a 4 oz. weight at the 12 o'clock position on the outside (right) of the wheel.

Note: If a weight is already in this position, place the 4 oz. weight as close to the indicated location as possible. Rotate it to the 12 o'clock position, and then press the Star (*) key.

12. Push the START button, or lower the hood. The balancer should now cycle and come to a stop.

13. The outer (right) weight display should read 4.00 ± .02 oz. and the center position LED for the outside (right) plane should be flashing when the weight is at bottom dead center. The display will now read CALIBRATION COMPLETE! PRESS ANY KEY TO CONTINUE.

14. Perform PLANE SEPARATION, if specified results are achieved calibration is complete. If specified results are not achieved, OPTIMIZE THE A.

15. Make sure to write down the new A value to use in the ARM CALIBRATION procedure. Center position LED for the outside (right) plane should be flashing when the weight is at bottom dead center. The display will now read CALIBRATION COMPLETE! PRESS ANY KEY TO CONTINUE.

Plane Separation (Accuracy Check)

1. Remove the 4 oz. weight from the wheel.

2. Use putty to fine balance the test wheel to obtain 0.00 (+0.02) weight readings on both planes. If unable to balance to zero See REPEATABILITY PROBLEMS.

Note: If the customer balances mostly larger wheels you may use a larger wheel for calibration.

3. Place a 4 oz. weight on the outside of the wheel.

4. Press start, or lower the guard hood. The readings for this cycle should be as follows:

Inner (Left) Plane = 0.00 ± 0.15 oz.

Outer (Right) Plane = 4.00 ± 0.15 oz.

Outer Position flashing = 4oz. at bottom dead center ± 1/2inch

5. Move the 4 oz. weight directly across to the inside plane. Press start, the reading should be as follows:

Inner (Left) Plane = 4.00 ± 0.15 oz.

Outer (Right) Plane = 0.00 ± 0.15 oz.

Inner Position flashing = 4oz. at bottom dead center ± 1/2 inch

6. If the above results are not achieved check the A, W, and, D dimensions. The ARM must be OPTIMIZED. Perform the ARM CALIBRATION.

7. If the above results are still not achieved, check the placement of the distance tape, see OPTIMIZING A(Distance Tape Placement).

8. If specified results are not achieved see ACCURACY PROBLEMS.

Optimizing A (Distance Gauge Tape Placement)

Note: Perform this procedure if the PLANE SEPARATION (Accuracy Check) fails.

1. Place a 4oz. wt. on the inside of the wheel, try entering an A dimension .1 higher than the one used originally. Spin the wheel. If the plane separation gets worse, try using an A dimension .1 lower than the one used originally.

2. If the plane separation gets better, keep increasing or decreasing the A dimension until an acceptable value is achieved.

3. Calibrate the machine and perform the PLANE SEPARATION CHECK. Repeat this procedure until the outer plane weight reading is at a minimum.

4. Once the A is Optimized and the distance tape moved, you must perform ARM CALIBRATION and BALANCER CALIBRATION with the new A value. Also recheck the PLANE SEPARATION.

5. Move the distance tape to this position to allow for proper A dimension entry.

Arm Calibration

1. Go to the menu and select CALIBRATION, select CALIBRATE ARM. Follow the instructions on the display. The A & D pot readings are displayed on the LCD display. With the arm in the HOME position, the readings should be within the tolerance brackets.

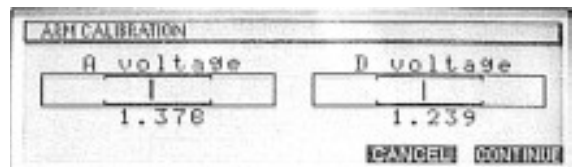

If not, the potentiometers should be adjusted. Refer to the A & D Arm Repair Procedures.

2. Place the arm in the **home position** (see decal on the motor). Follow the instructions on the display screen.

3. The A value is obtained by moving the distance arm out to the rim, and manually entering the new A value obtained from the PLANE SEPARATION and A OPTIMIZATION.

Direct Drive

4. Enter the D value from the tire. It should be within .10 of the reading from the automatic arm, if not the D pot should be adjusted (refer to A & D ARM REPAIR PROCEDURES). Manually enter the value.

5. After both values have been manually entered, move the distance arm to the rim and hold it in position while pressing CONTINUE.

6. Rotate the arm out and around to a second position on the rim. Holding the tip against the rim flange, press CONTINUE.

Arm Calibration is now complete. When the arm is returned to the HOME position, the balancer will return normal operating mode.

7. To verify the calibration, pull the arm out and hold the tip against the rim flange. The A & D readings automatically displayed should be +0.20 of the values entered during calibration. If not, see OPTIMIZING A (DISTANCE TAPE PLACEMENT) and A & D Arm Problems.

Accuracy Problems

Mounting Errors - Causes comebacks but not detectable with the balance. Check the runout of the shaft, faceplate and cones.

Wheel Slipping During Rotation - Causes repeated spins or inability to balance the wheel. Check by marking the wheel & faceplate, correct by tightening the hub nut or using front cone.

Improper Wheel Parameters - or Inaccurate Wheel parameters such as approximate ALU modes. Causes inability to balance the wheel. Enter more accurate parameters and or mount hidden weight closer to the PRESET position for hidden weights.

Uncalibrated Data Entry Arm - Causes repeated spins to balance. Perform Plane Separation (Accuracy Check)

Uncalibrated Balancer - Causes repeated spins to balance. Perform a PLANE Separation (Accuracy Check).

Something Touching The Motor Or Distance Arm - Causes inability to calibrate the balancer or achieve acceptable PLANE SEPARATION. Check for anything touching the motor.

Rotary Shutter Slipping - Causes weight position to change, repeat spins, or inability to balance. Perform Rotary Shutter Checking Procedure.

Rotation Check

Note: This procedure must be performed with a "Hub Centric" wheel. It should be performed as part of every routine calibration procedure.

1. Remove the 4oz. weight from the inner rim and perform a fine balance to obtain 0.00 (+.02) weight readings on inner and outer plane.

2. Position valve stem at 6 o'clock. Loosen hub nut just enough to allow the wheel to move. While holding the faceplate so it cannot turn, rotate the wheel 90 degrees relative to the faceplate. Tighten hub nut.

3. Press START. Weight readings should be 0.32 oz. or less.

4. Repeat steps 2 & 3. At 180 and 270 degrees weight readings should be .32 oz. or less.

5. If the specified results are not achieved see ROTATIONAL PROBLEMS.

Cycle Counters

These counters can be accessed through the DIAGNOSTICS menu. Each cycle counter is different. They may be beneficial to the shop owner as a management tool.

User Counter - can be reset at any time by anyone to determine number of spins per day, hour, or per user.

Calibration Counter - this automatically resets each time the balancer is calibrated. It can be a useful tool to see how often the balancer is being calibrated. As a routine this should be checked when a customer complains of weight chasing or calibration problems. A low count could indicate the customer is calibrating too often or calibrating incorrectly.

Total Counts - counts the total number of cycles on the balancer. It is not resettable, however if the CPU board is ever replaced it will reset.

Total Accuracy Verification (TVA)

Total Accuracy Verification or TAV means that when the balancer shows zeros in the weight display after balancing the wheel it is truly balanced. The model IBS 2000 includes software that will allow the user to check the accuracy of his machine periodically. The procedure is detailed below.

1. Go to the Main Menu and select SETUP. Press enter.
2. Arrow through the selections to TAV. Press enter.
3. The menu will now display several "preset" selections to choose from, or the customer may wish to SPECIFY. Press Enter.
4. If SPECIFY is selected, the menu will prompt to enter the number of cycles desired. Enter the number and press enter.

Note: If the preset number is less than 250 the first message will appear at the preset number. Subsequent messages will also appear at that interval.

Example A:

<i>Cycles Since Last Calibration</i>	<i>Message</i>
10	The preset number of TAV cycles has been reached, do you wish to perform TAV?
20	The preset number of TAV cycles has been exceeded, do you wish to perform TAV?

5. If NO is selected, the balancer will resume normal operation.

Note: If the preset number is equal to or greater than 250, the first message will appear at the preset number and again every 250 cycles.

Example B:

<i>Cycles Since Last Calibration</i>	<i>Message</i>
500	The preset number of TAV cycles has been reached, do you wish to perform TAV?
750	The preset number of TAV cycles has been exceeded, do you wish to perform TAV?

7. If YES is selected, the balancer will automatically enter the calibration mode. Follow the instructions on the display.

Error Codes

LED Error Codes

When the balancer is powered up, several communication checks are made. If the data is incorrect, or not received the balancer generates the following error codes in the weight amount LED's on the display.

LCD ERR - unable to communicate with LCD: Displayed when the Display board is unable to communicate with LCD board. This halts the program. Check the LCD ribbon, and all connections. Most likely the ribbon is not installed properly, backwards or on wrong pins. Possibly the LCD board.

EE ERR - unable to communicate with the EE PROM: Displayed when the EE PROM (on the display board) cannot read or write. It cannot restore display settings, this is a combination of messages 7 and 8. Replace the display board.

LCD Error Codes

The following list of error codes, are Built In Safety Features. When the balancer is cycled several operating parameters are checked. If one of these parameters is not within tolerance, the machine will generate an error message displayed on the LCD readout. An explanation of these messages and troubleshooting procedure is listed below:

#1 - The Motor Speed Was Excessive: Displayed when the motor exceeds normal operating speed at any time during the cycle. Check the SSR (solid state relay).

#2 - Time To Reach Minimum Operating Speed Too Long: Displayed when time to reach the minimum operating speed is greater than 20 seconds. Check cables, SSR, or CPU.

#3 - Time To Reach Maximum Operating Speed Too Long: Displayed when time to reach maximum operating speed exceeds 14 seconds. Check cables, SSR, or CPU.

#4 - The Measurement Time Was Too Long: Displayed after the motor gets up to speed but the time to set GAIN (an internal measurement) is too long. Check cables, optical encoder, or CPU.

#5 - The Measurement Time Was Too Long: Displayed when the time to FILTER (an internal process) is too long. Check cables, optical encoder, or CPU.

#6 - Not Used.

#7 - Internal Error Code: Displayed when a write error on the EE PROM (of the CPU board) has occurred. Calibration information, counters, etc. Replace CPU board.

Direct Drive

#8 - Internal Error Code: Displayed at power up when the data on the EE PROM is different than when the unit was turned off. Recalibrate the Balancer and the A/D Arm. If this message continues replace the CPU board.

#9 - An Invalid Model Selection Has Been Made: Displayed when the dipswitches on the CPU board are not set correctly, or the connections are bad. Check the dipswitch settings (they should all be in the ON position) and reset if necessary. If this does not correct the problem, replace the CPU.

#10 - The Automatic Arm Is Not Present: Displayed during Arm Calibration when the CPU cannot detect the arm. Check the arm cable/PCB connections, or the CPU connector.

#11 - The A & D Pots Are Not Properly Adjusted: Displayed during Arm Calibration if the pots were not properly adjusted. Press CONTINUE to readjust, or CANCEL to quit.

#12 - The A Pot Is Not Properly Adjusted: Displayed when the A pot is not reading correctly. Same as #11 except for the A pot only. Press CONTINUE to readjust, or CANCEL to quit.

#13 - The D Pot Is Not Properly Adjusted: Displayed when the D pot is not reading correctly, Same as #12 except for the D pot only. Press CONTINUE to readjust, or CANCEL to quit.

#14 - The Hood Was Raised During The Measurement Cycle: Displayed if the hood is raised during the cycle. Lower the hood and respin.

#15 - The Motor Ran In Reverse At Start Up: Displayed when the motor accelerated in reverse at start up. Check phase, AC power, or MC (motor controller).

#16 - The Arm Was Not In The Correct Position: Displayed during Arm Calibration if you get out of sequence. Press CONTINUE to repeat or CANCEL to quit.

#17 - No Encoder Pulses At Start Up: Displayed when no encoder is detected at start up. Check cable, AC power and motor. Refer to "Wheel Does Not Spin" flow chart.

#18 - No Phase A Encoder Pulse At Start Up: Same as #17, but for Phase A only. See "Wheel Does Not Spin" flow chart.

#19 - No Phase B Encoder Pulse At Start Up: Same as #17, but for Phase B only. See "Wheel Does Not Spin" flow chart.

#20 - The Hub Nut Is Loose Or There Is No Wheel Mounted: Displayed when the hub nut is not tight and the wheel slips, or the faceplate assembly is not tight

on the motor shaft. Recheck the hubnut or refer to "Faceplate Assembly Installation" on pg. 5. Press CONTINUE to proceed.

#21 - The Wheel Is Turning Too Fast For A Measurement To Be Made: The motor speed is greater than the maximum operating speed.

#22 - The Wheel Turned In Reverse After The Motor Was Started: Displayed when something interferes with the rotation of the wheel after start up (someone holding the wheel). Press CONTINUE to proceed. Check cables or SSR. Press CONTINUE to proceed.

#23 - The Wheel Turned Too Slow: Displayed under similar conditions as #22. Check cables or SSR. Press CONTINUE to proceed.

#24 - The Motor Accelerated Forward During Breaking: Displayed when there is a phase problem with the SSR, very rare. Check loose shutter wheel or loose faceplate. Check encoder cable, AC power, motor, and SSR. Press CONTINUE to proceed.

#25 - The Time Required To Stop The Motor Was Too Long: Displayed if a phase is lost on the SSR. Check AC power, cables, and SSR. Press CONTINUE to proceed.

Direct Drive

Troubleshooting Flow Charts

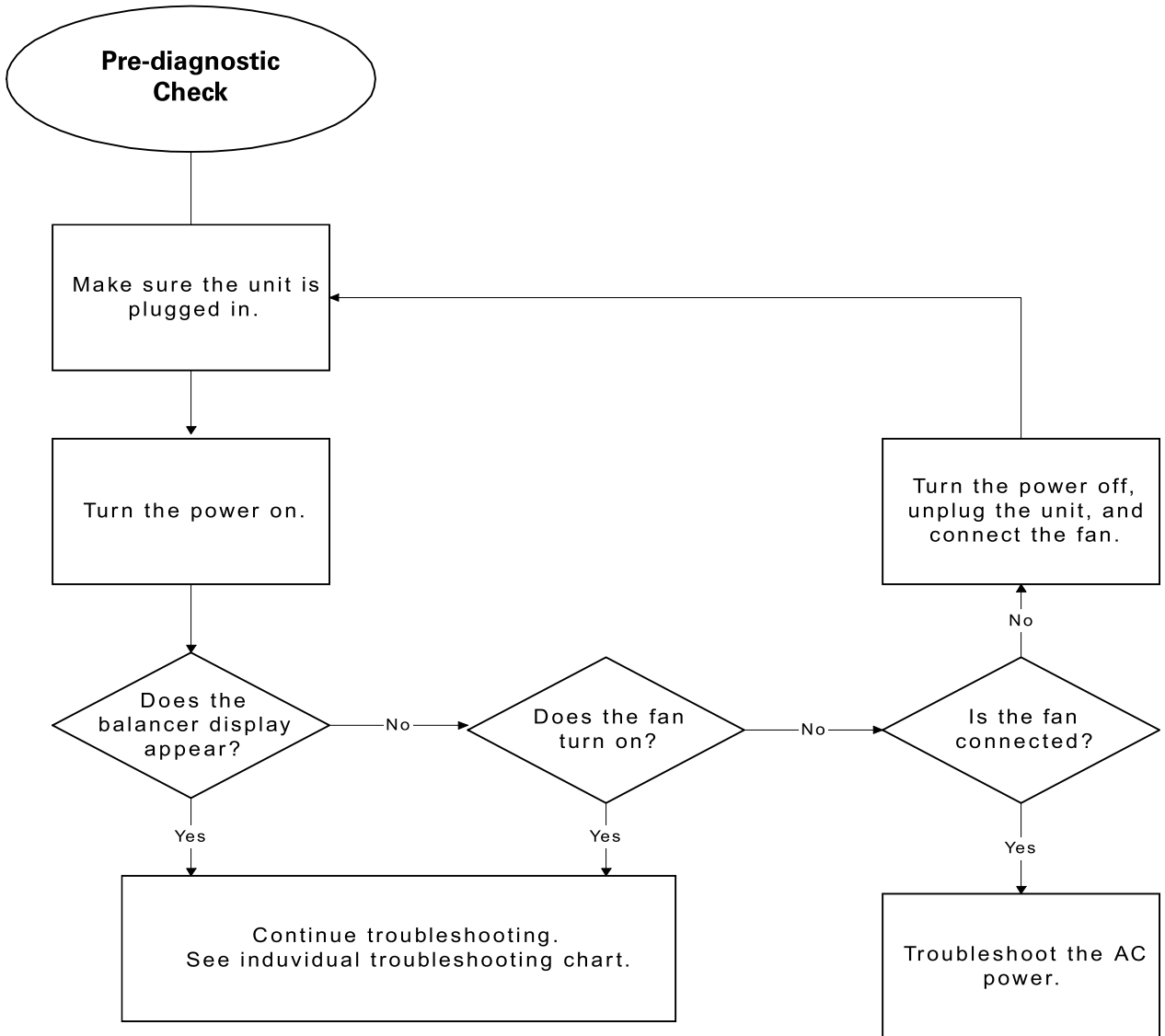

Direct Drive

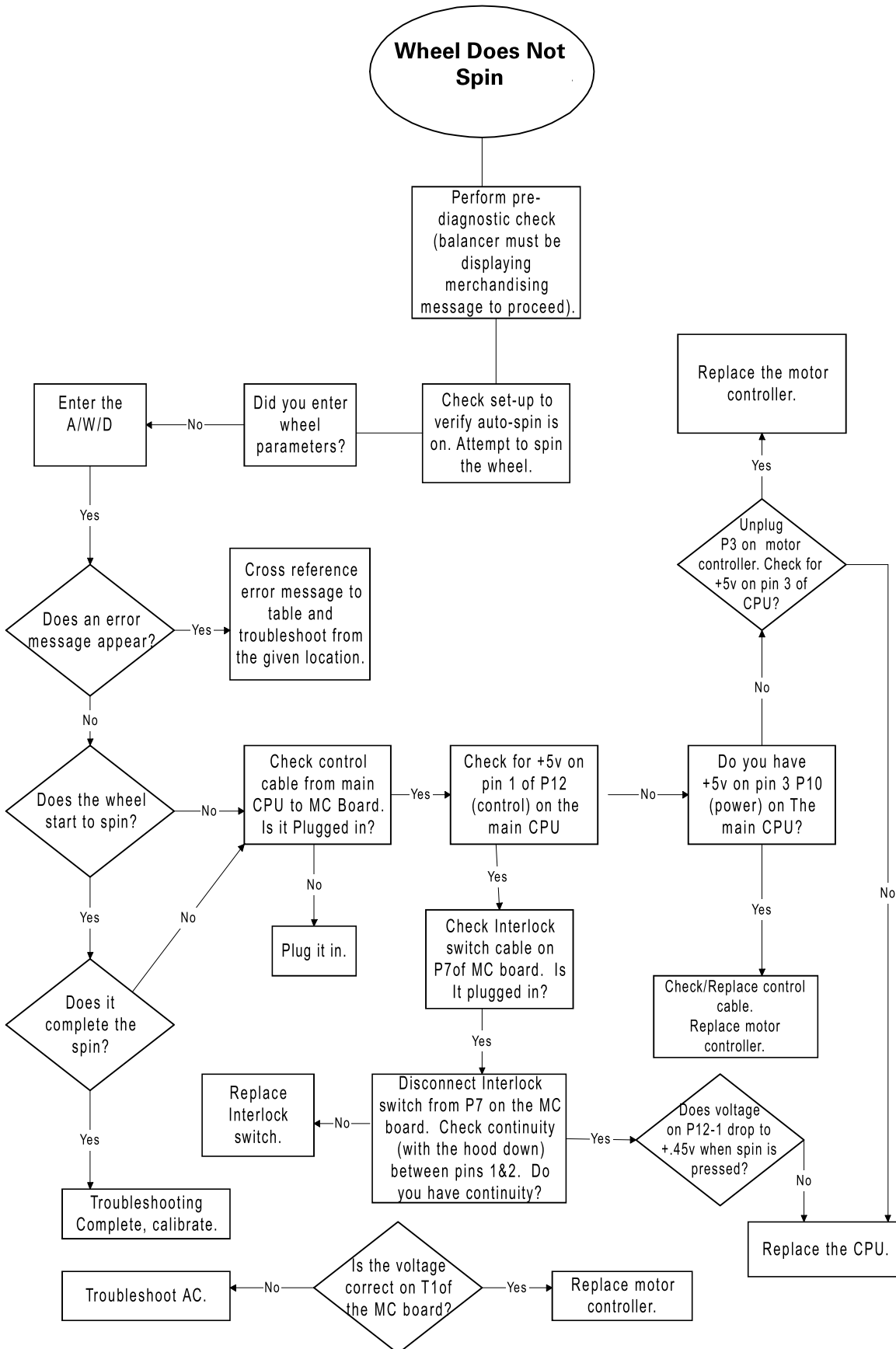

Direct Drive

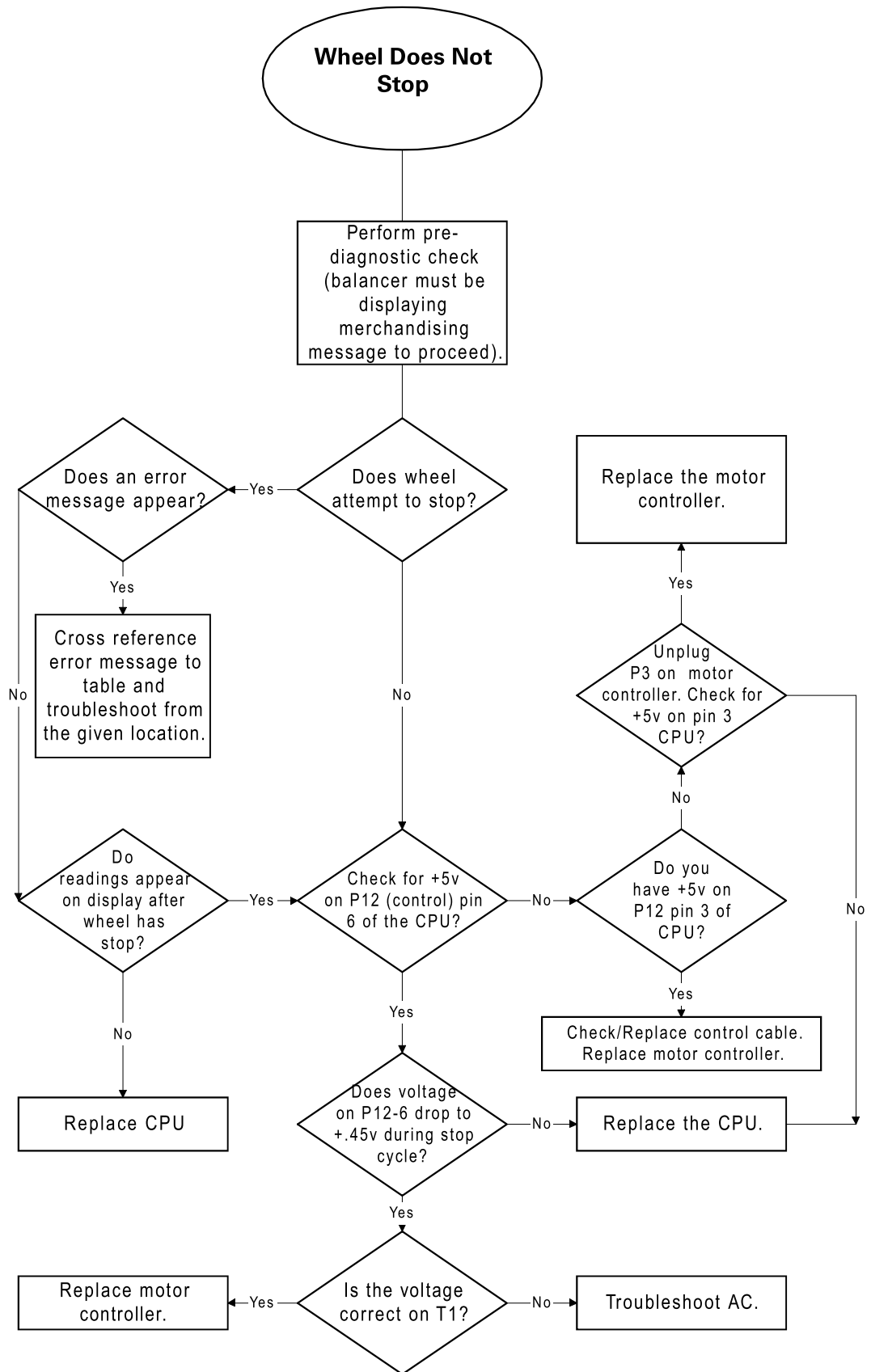

Direct Drive

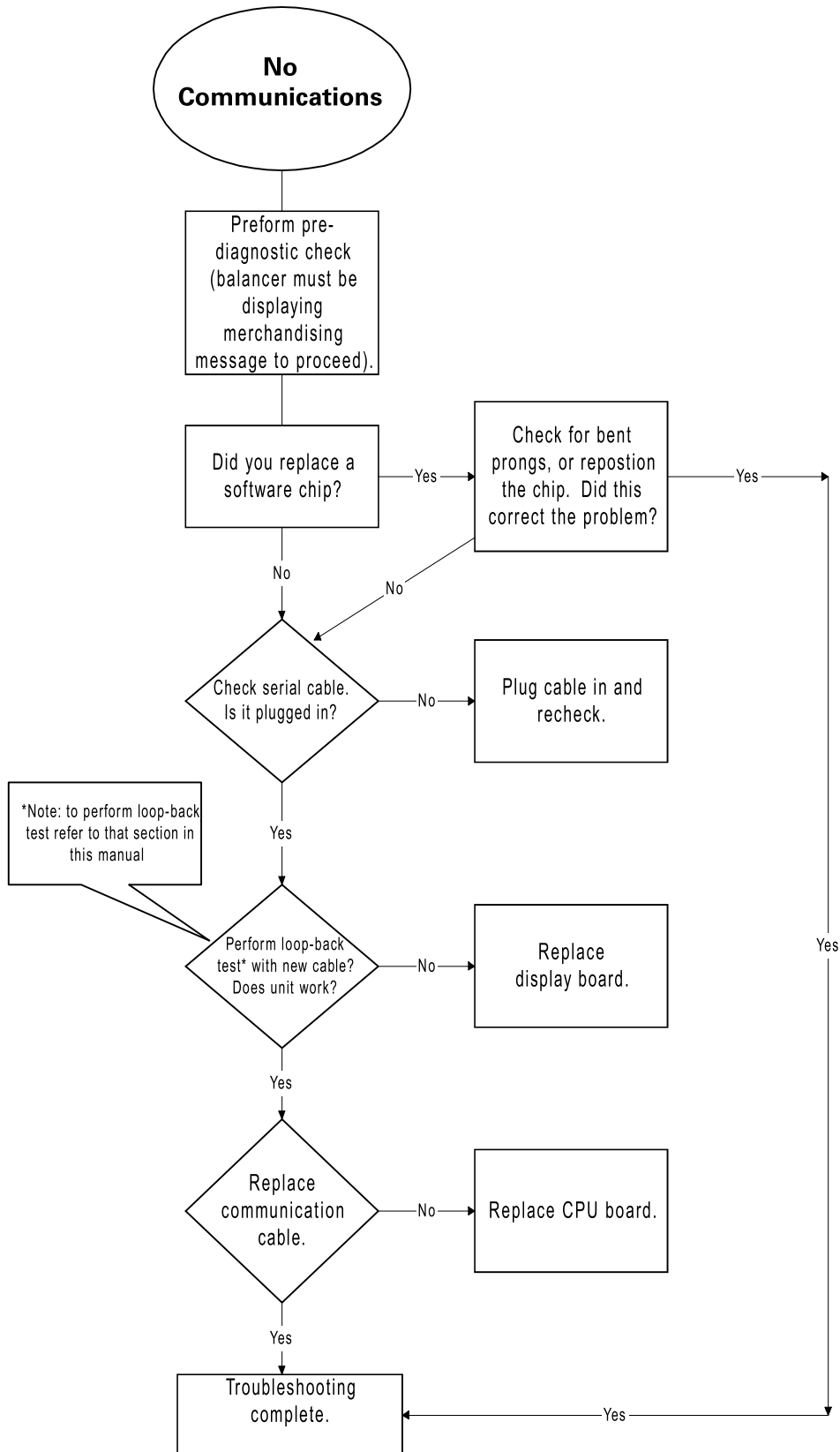

Direct Drive

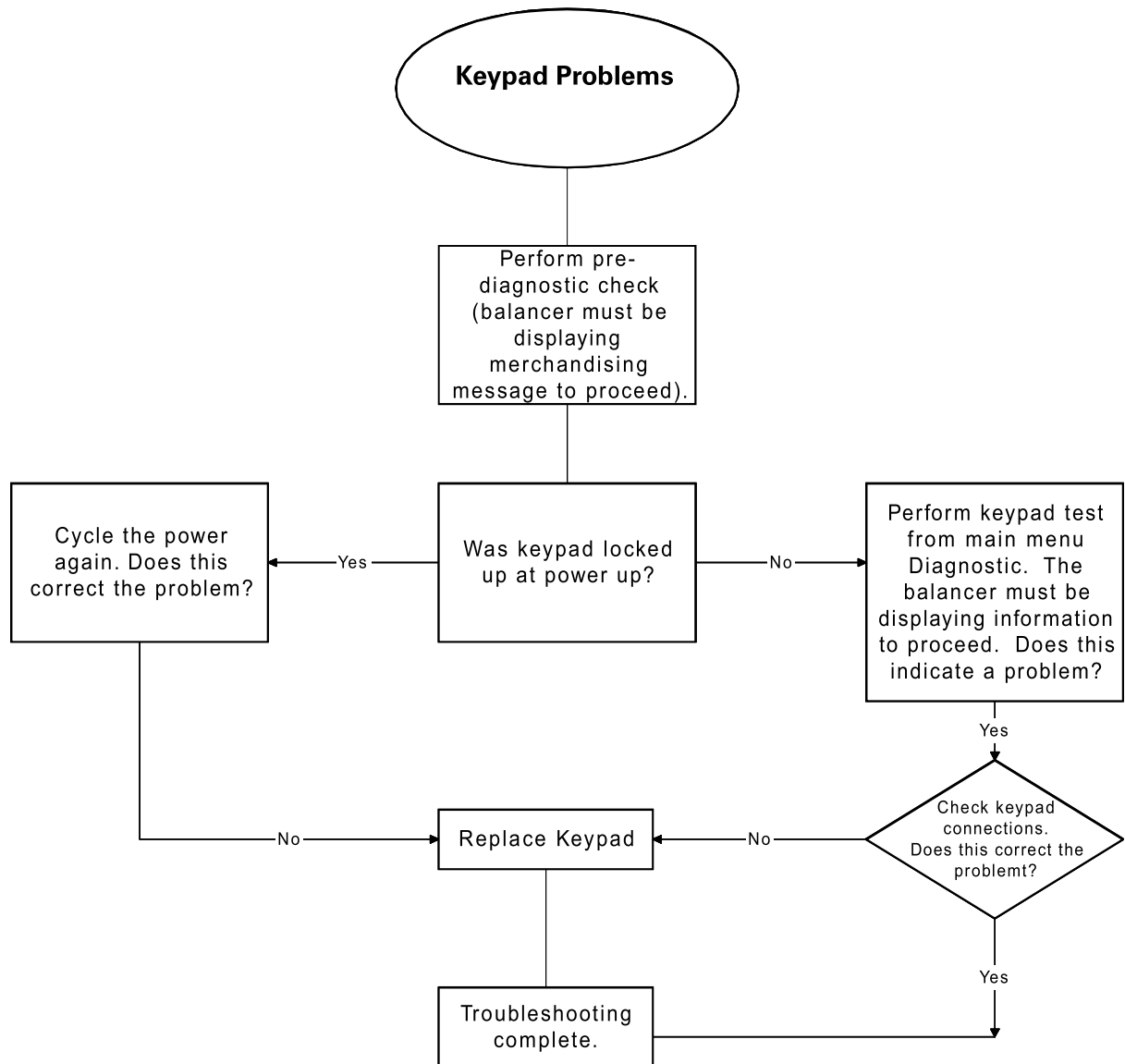

NOTE: When a key is shorted or locked down at power up,

1. the LCD may be lighted but blank.
2. the "Press Any Key to Continue" message may be displayed.
3. the LCD may be in another mode such as:
ADJUST LCD CONTRAST
BALANCER DISPLAY DIAGNOSTICS

Direct Drive

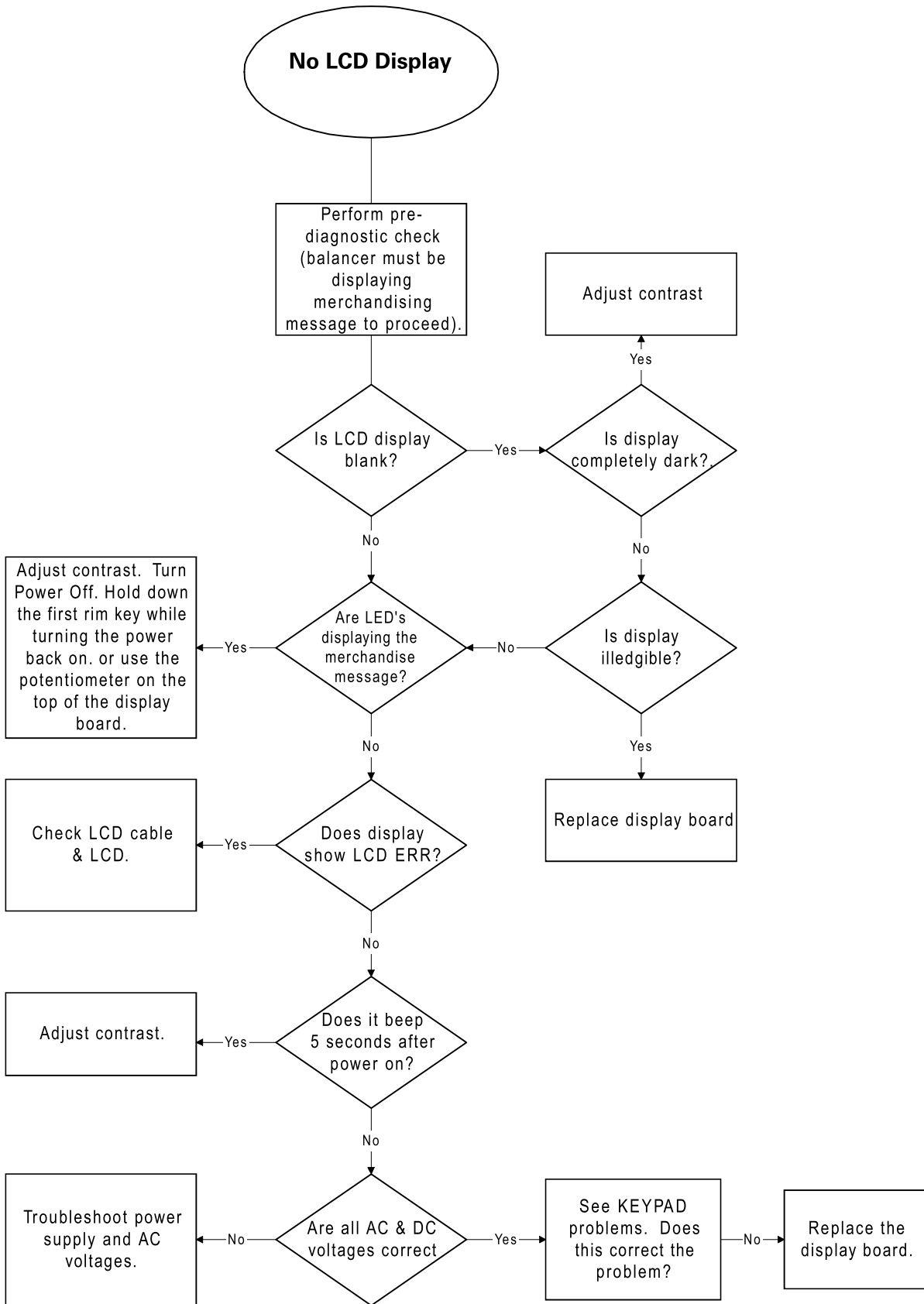

Direct Drive

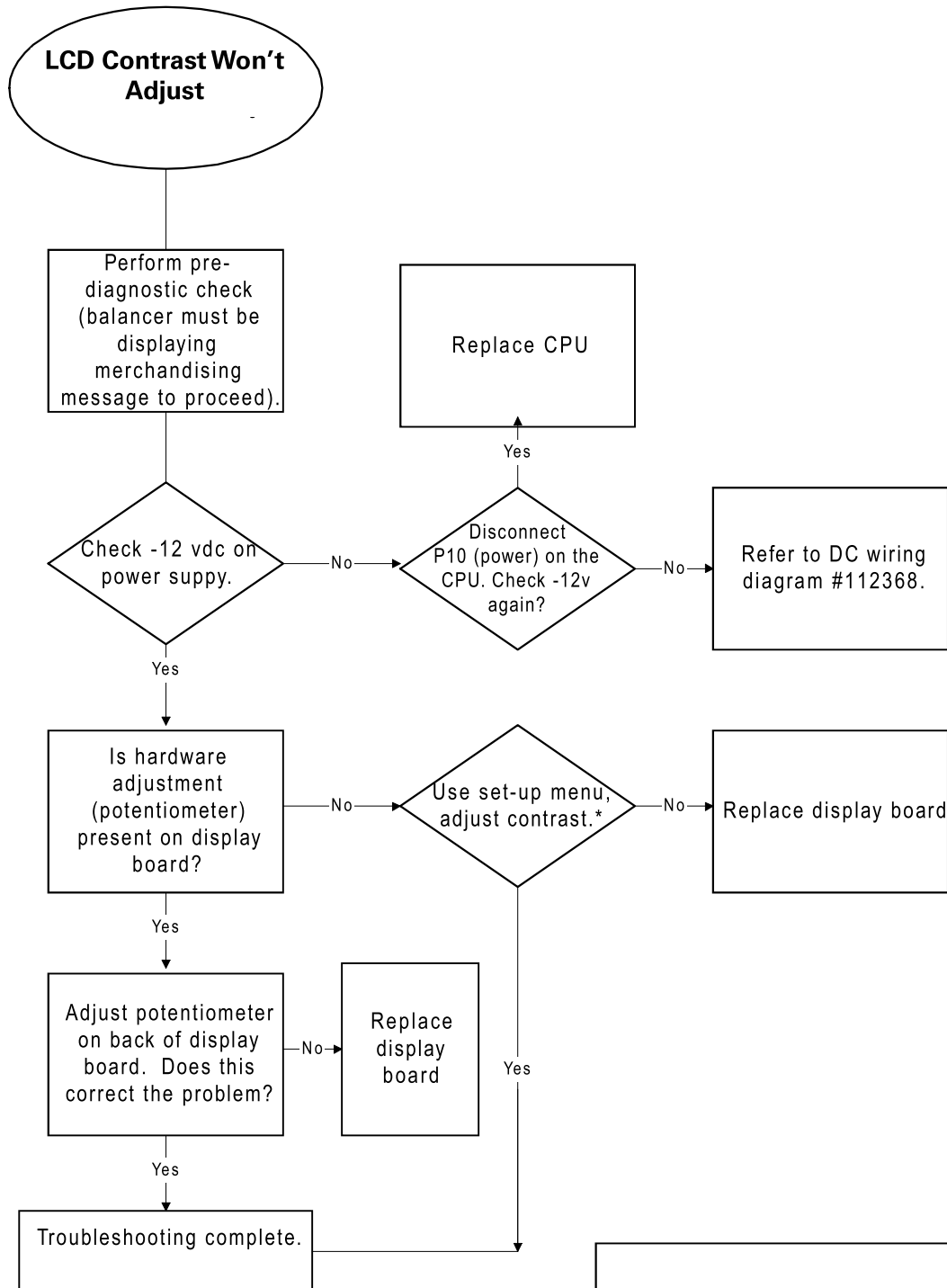

***NOTE:** Turn the power off. While holding down the first (from the left) rim weight locator key, Turn the power back on. This will get you into the contrast adjustment mode. Adjust as necessary and Save setting.

Direct Drive

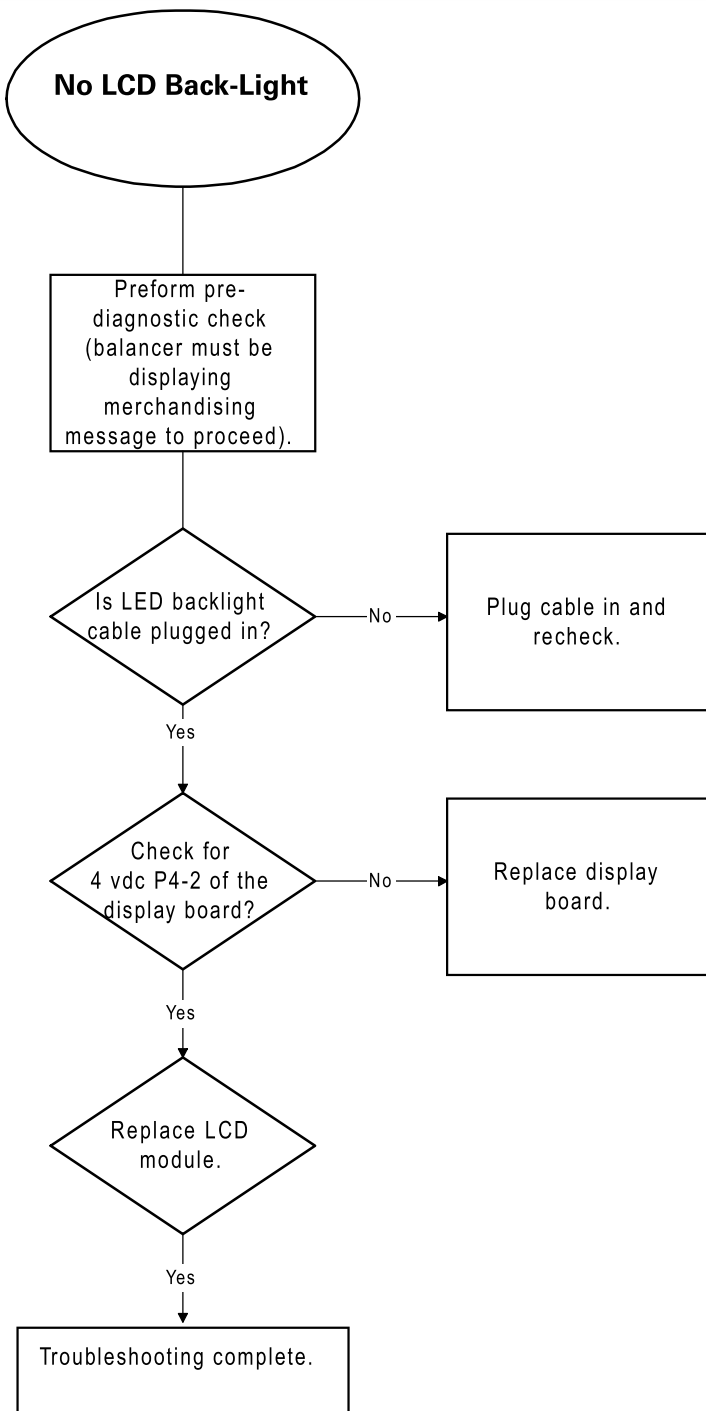

Direct Drive

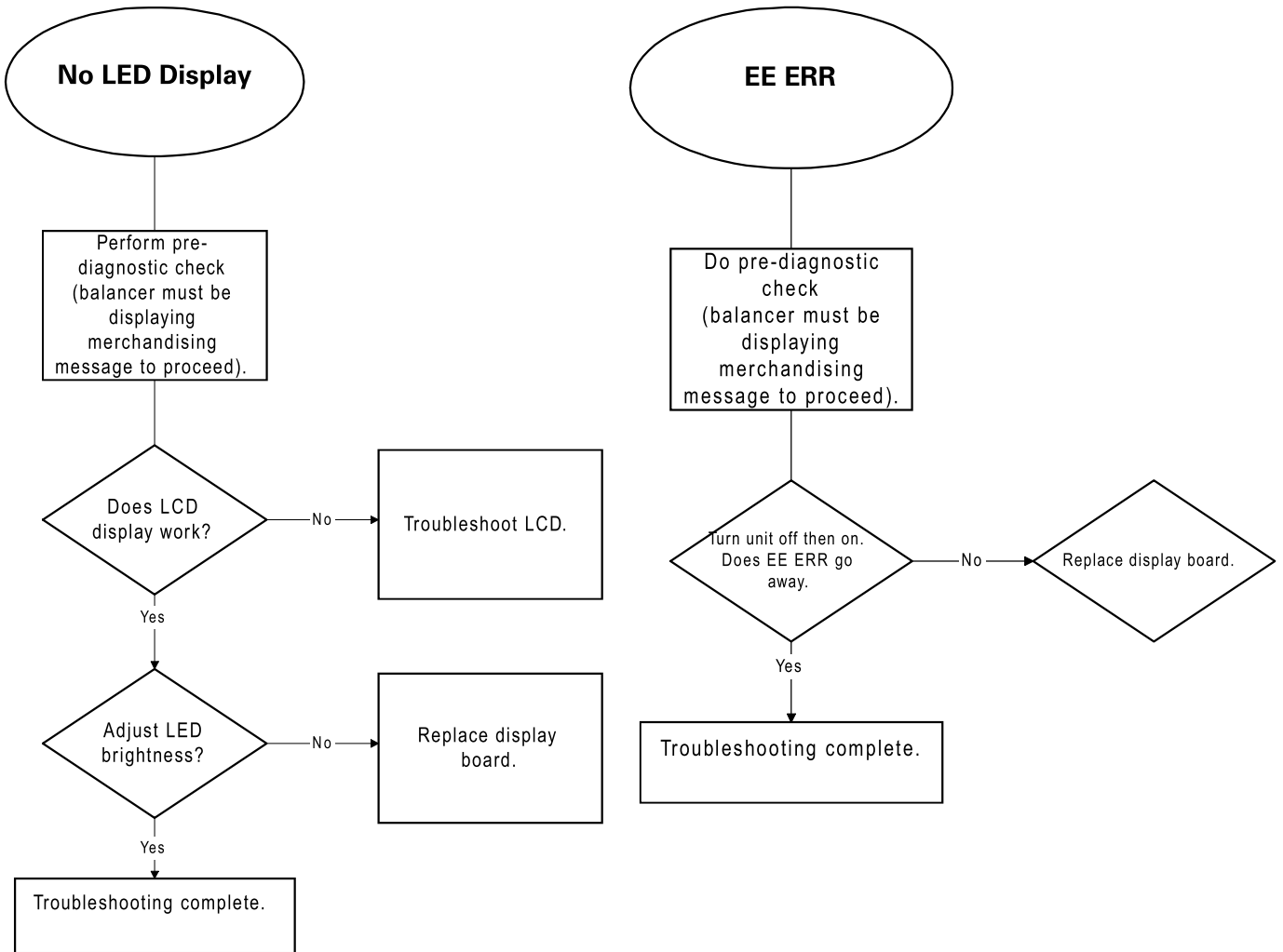

Direct Drive

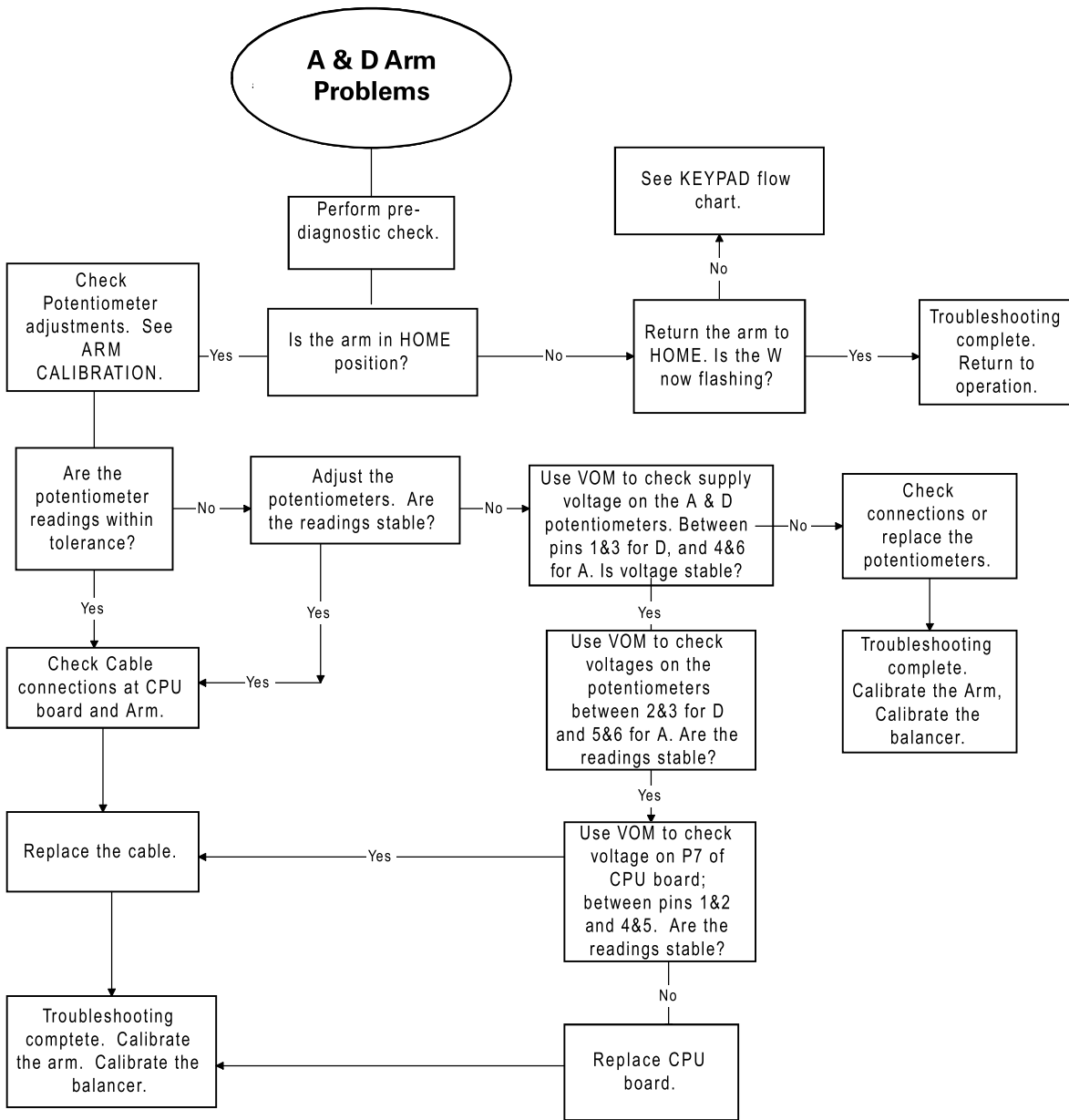

Direct Drive

Diagnostic Procedures

Motor and Motor Controller Checking Procedure

To verify the operation of the motor and motor controller the SSR's (Solid State Relays) must be activated. To do this it is necessary to simulate the signal produced by the CPU.

Note: Use of an in-line adapter is recommended for this procedure, like the one from Contact East, (part #118-785 Modapt Modular Adapter). For ordering information call, 1-800-225-5334.

Caution! If the spin and brake are activated at the same time, the motor controller will be destroyed!

Note: Use CIRCUIT GROUND for checking voltages. Refer to the wiring diagram #112368, in the back of this book.

1. Check for 5 vdc on the CPU location P12/CONTROL pins 1, 3 and 6 (Tabs 2, 4 and 7 of the Modapt Adapter). If Voltage is not present refer to the DC voltage checks.

2. To activate the spin, connect a jumper to circuit ground and touch pin 1 of P12/CONTROL (Tab 2 of the Modapt adapter). The motor should run clockwise. If the motor fails to respond refer to the WHEEL DOES NOT SPIN trouble shooting guide.

CAUTION! DO NOT perform this procedure for more than Two (2) seconds.

3. To activate the brake connect a jumper to circuit ground and touch pin 6 of P12/CONTROL (Tab 7 of the Modapt Adapter) The motor should spin counter clockwise. If the motor fails to respond, refer to the WHEEL DOES NOT STOP trouble shooting guide.

Caution! DO NOT perform this procedure for more than Two (2) seconds.

Spin & Stop Diagram

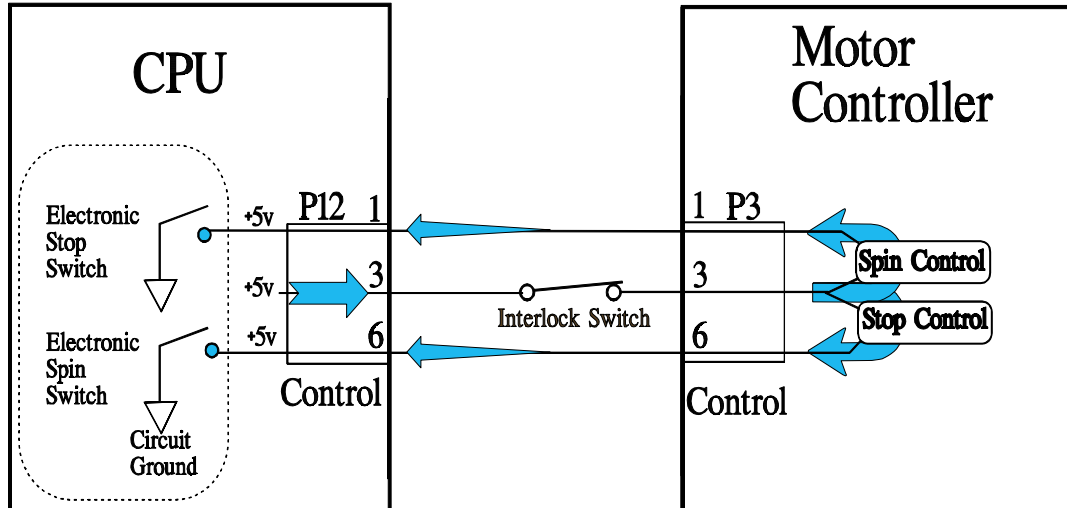

Modapt adaptor
Contact East #118-785
1-800-225-5334

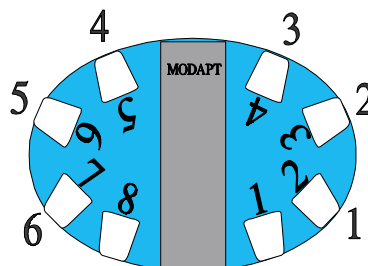

NOTE:
Outside numbers are
for a 6 pin connector.

3-13-98

Direct Drive

Motor Controller Diagram

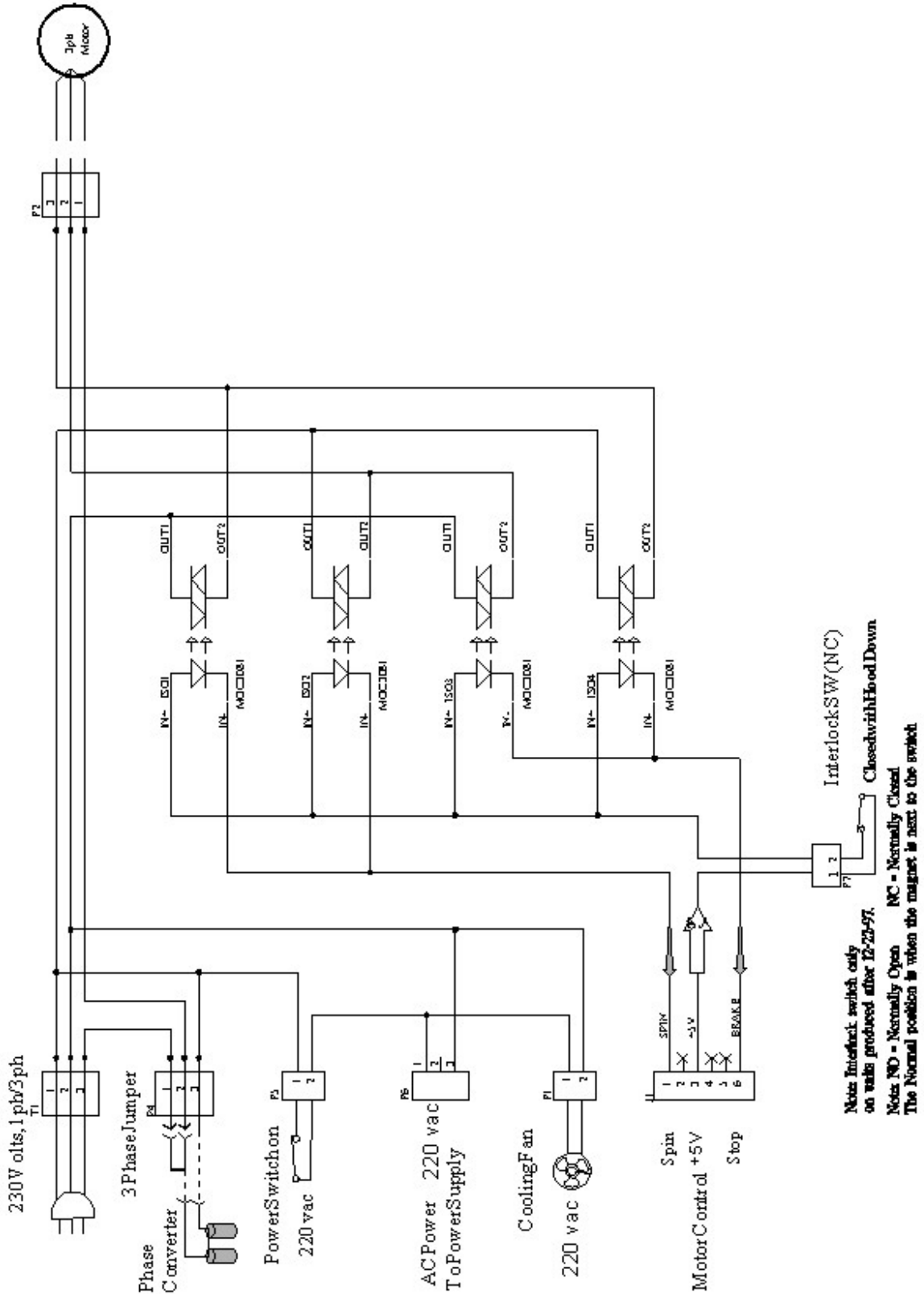

Direct Drive

Optical Encoder Checking Procedure

This procedure allows you to check the optical encoder to determine if it is operating properly. A defective encoder can result in spin or braking problems.

1. When reading the voltages on the white and green wires, turn the faceplate **slowly** by hand. The low voltage must be less than .7VDC. The high voltages must be greater than 4.0VDC.

2. Voltage readings are taken with all optical encoder wires connected.

Lead Color	Voltage
GREEN to PURPLE	- $2.4 \pm .5$ VDC
YELLOW to PURPLE	- Less than .7VDC; greater than 4VDC
BLUE to PURPLE	- Less than .7VDC; greater than 4VDC

Refer to the wiring diagram.

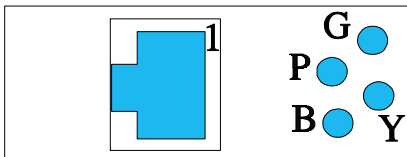

Rotary Shutter Checking Procedure

This procedure will detect movement of the rotary shutter during a spin cycle. Slippage of the shutter wheel can cause the weight location to change resulting in weight chasing, or spin error messages as a result of an incorrect encoder count.

1. Mount a balanced wheel on the machine. Add a 4 oz. weight to the outside plane and spin the wheel.

2. Rotate the wheel so the center position LED light is on. Mark the tire or wheel with respect to the witness mark on the motor.

3. Spin the wheel again, then rotate the wheel so the center position light comes on again. Note the position of the mark you made on the tire or wheel. You may need to make several spins.

4. If the position changes, the rotary shutter has slipped. Refer to the Rotary Shutter Replacement procedure to tighten and recheck.

Note: This procedure can be used to check for loose faceplate, however mark the faceplate instead of the wheel.

Piezo Output Test

This procedure allows you to look at the piezo output readings to diagnose a problem with any of the piezos. Piezo problems can cause incorrect weight readings resulting in weight chasing problems.

1. Go to the main menu and select DIAGNOSTICS, press enter.

2. Select PIEZO OUTPUTS, press enter. The screen will now display the piezo readings. Each piezo is measured individually, L = left, RF = right front, and RR = right rear.

3. The amplitude reading is the one we will refer to for diagnosis. Only use the first number to the right of the decimal, disregard all others.

4. Using a balanced wheel, put a 4oz. weight on the outside, spin the wheel. The left reading should be approximately 25% less than the right front and right rear readings. Both right readings should be approximately the same.

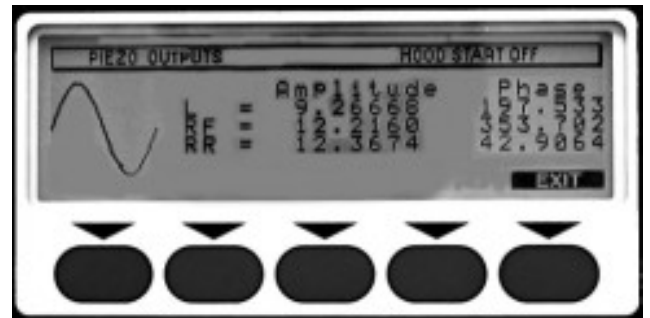

5. Spin the wheel for several revolutions and note the readings in between each spin. Look for consistency in the readings.

6. Now remove the 4 oz. wt., with a balanced wheel add a 1 oz. weight to the outside of the wheel. Spin the wheel and check the piezo outputs. Add a 2 oz. weight where the 1 oz. was, and spin the wheel. The readings should double. Add a 3 oz. weight and the readings should triple.

Note: If the readings fluctuate a great deal check the piezo connector and refer to the "Piezo Replacement Procedures".

Direct Drive

Piezo Crystal Checking Procedure

This procedure details how to check for an “upside down” piezo assembly (the crystal has been assembled upside down inside the piezo assembly). This can result in various problems; primarily high weight readings, or the position may read 180 degrees out. The piezos may be checked in or out of the balancer. The procedure below details checking them in the balancer.

1. Using a Digital Volt Meter select the DC setting.
2. Connect the red (positive) lead to the piezo tap.
3. Connect the black (negative) lead to ground (the bottom of the piezo assembly).
4. The meter may indicate a fluctuating or negative reading, ignore the reading at this time.
5. Apply firm downward pressure to the front of the motor (if out of the balancer apply pressure directly to the piezo) and note the signal.
6. If the piezo is good, the signal should read positive (+) at the instant pressure is applied for **right* piezos.
7. If the piezo assembly is “upside down” the signal will read negative (-) at the instant pressure is applied for **right* piezos.

***Note: When checking the *left* piezo the readings in step 6 and 7 will be opposite.**

Balancer Display Diagnostics

This is a diagnostic menu that should only be accessed by authorized Hennessy service personnel. It allows you to perform tests on the components within the POD. To access this menu you press the PLANE 2 key on the WEIGHT LOCATOR display and turn the power on simultaneously. You may use the RS232 cable or a spare “test” cable. The menu will display several tests. Each test will display step by step instructions.

Tests on this Menu Include:

- KEY PAD TEST
- LCD TEST
- LED TEST
- RAM TEST

Note: This is not the same RAM test on the main diagnostic menu. This RAM test is for the LCD board.

- SOFTWARE REVISION
- SERIAL LOOPBACK TEST

Serial Loopback Test

This is a Display Board software communication test. It checks the transmitted and received data. Follow the instructions on the screen.

1. Connect a cable between the CPU1 (P3) and TEST (P2) connections on the top of the display board. Refer to the wiring diagram #112368 on Press CONTINUE.
2. The screen will not display the **Transmit** data and the **Received** data.
3. You will then receive a PASSED or FAILED message.

Note: If the test FAILED, check and replace the cable or the display board. If the test PASSED, but you still get a communication error, check the CPU board RS232 cable or the CPU board itself.

Direct Drive

Parts Replacement Procedures for Model IBS 2000 Balancer

The procedures in this section will aid in replacing major subassemblies of the IBS 2000 balancer.

Do not disassemble, adjust or replace any part before performing the PRELIMINARY INSPECTION and FUNCTIONAL CHECK PROCEDURES. These procedures, along with the troubleshooting flow charts, will isolate the necessary adjustment or replacement. Perform checks in the order listed and exactly as specified.

Refer to the exploded parts view, parts list and wiring diagrams in this manual for parts identification. Standard commercial fittings and fasteners are used throughout and should be obtained locally.

Check all interconnecting wiring and connectors when an electrical malfunction is indicated. Check all fittings and fasteners when a mechanical malfunction is indicated.

New Repair Procedure - The model IBS 2000 is different from other Coats balancers in that it contains five (5) separate boards which can be replaced individually. Always refer to the Trouble Shooting section for diagnostic instructions to isolate the defective assembly.

Note: ALWAYS REFER TO THE WIRING DIAGRAM (#112368) in the back of this book for the following procedures.

Display Board Assembly Replacement

1. Unplug the balancer.
2. Remove the four (4) nuts on the back of the pod.
3. Disconnect the power supply wire from P1.
4. Disconnect the RS232 connector from P3.
5. Disconnect the (red) start switch wire from P8.
6. Disconnect the (grey) LCD backlight wire from P4.
7. Disconnect LCD ribbon from P5.
8. Remove the four (4) screws from the display board.
9. Carefully raise the board, and disconnect the keypad ribbon.

Caution! DO NOT raise the board more than 4-5 inches or you will destroy the keypad ribbon.

10. Replace the defective Display board and reinstall in reverse order.

11. Plug balancer in.

12. Perform FUNCTION CHECKS.

Caution! If the (red) start switch wire P8 and the (grey) LCD backlight wire P4 are not connected in the correct location of the Display Board; the LCD will work, and the LED's will light momentarily. The start switch will not work, then the LED's will blank.

Caution! If the RS232 Cable is in the wrong port the communication is disrupted and you will get a WARNING! COMMUNICATION HAS BEEN Disrupted. Check Serial Cable.

Note: The display board contains a replaceable E-prom chip for software revision. The above procedures should be followed in order to access this chip. Actual chip replacement procedures are detailed next.

E-Prom Replacement

Caution! Touch the balancer to discharge any static electricity in your body before servicing an E-Prom. A static strap should be worn. Static electricity can damage the chip.

1. Unplug the balancer.
2. Follow the DISPLAY BOARD REPLACEMENT procedures. Once you disconnect the keypad ribbon, you can turn the board over and access the E-prom chip.
3. Note the orientation of the chip before removing. The top right corner is not square but cut diagonally, and there are two locator dots (top left and bottom right) on the chip.
4. Insert the jaws of the chip extractor (Ammco # 29977) into the slots of the E-Prom chip. Remove the chip.
5. Install new chip the same way, note the orientation.

Caution! Be careful not to damage the connector pins.

Note: The CPU Board also has an E-Prom chip which should be replaced at the same time, unless specified by the manufacturer.

6. Reinstall display board.
7. Plug balancer in.
8. Perform FUNCTION CHECKS.

Direct Drive

LCD Board Replacement

Caution! This is a liquid crystal display do not bend or apply direct pressure. Store in a static bag at temperatures between 32° F - 95° F. Do not exceed 70% humidity. Do not apply DC Voltage (see notes in PIEZO REPLACEMENT procedures).

1. Unplug the balancer.
2. Remove the four (4) nuts on the back of the pod.
3. Disconnect the (red) start switch wire from the switch.
4. Disconnect the (grey) LCD wire from P4 of the Display Board.
5. Disconnect the LCD ribbon from the LCD board.
6. Remove the four (4) screws holding the LCD Board to the Touch Panel.

Note: The LCD board has a locating arrow ? on the back in the upper right corner. Make sure the arrow is in the UP position before reinstalling the new LCD. To adjust the contrast there is an adjusting potentiometer on the top of the display board.

7. Install rubber O-rings between the LCD board and the Touch Panel standoffs. Refer to the Instruction sheet provided with the new part.
8. Replace the defective LCD Board and reinstall in reverse order.
9. Plug in balancer.
10. Perform FUNCTION CHECKS.

Start Switch Replacement

1. Disconnect balancer.
2. Remove the four (4) screws on the back of the pod.
3. Disconnect the (red) start switch wire from the switch.
4. Remove the three (3) screws from the start switch.
5. Replace the defective switch and reinstall in reverse order.
6. Plug in balancer.
7. Perform FUNCTION CHECKS.

Touch Panel Replacement

1. Disconnect balancer.
2. Follow all procedures for Display Board and LCD Board replacement.
3. Replace defective Touch Panel.
4. Plug in balancer.
5. Perform FUNCTION CHECKS.

Hood Magnet Replacement

1. Remove the rubber hood stop from the hood bracket on the chassis.
2. Lean the hood back as far as it will go.
3. Remove the magnet from the hood bar.
4. Install the new magnet. Make sure the nylon washer is between the magnet and the bracket. DO NOT OVERTIGHTEN.
5. Place the hood in the down position and install the rubber hood stop.
6. Check to make sure that the motor starts with the hood down, but not with it up. The IBS 2000 automatically defaults with HOOD START on.
7. Perform FUNCTION CHECKS.

Hood Switch Replacement

1. Unplug the balancer.
2. Remove the UL cover on the back of the hood support bracket by drilling out the pop rivets.
3. Remove two (2) screws holding hood switch to hood bracket and remove hood switch.
4. Disconnect two (2) wires going to hood switch.
5. Connect wires to new hood switch and install.
6. Plug in the balancer.
7. Check to make sure that the motor starts with the hood down, but not with it up.
8. Perform FUNCTION CHECKS.

Safety Interlock Switch Replacement

1. Unplug the balancer.
2. Remove the UL cover on the back of the hood support bracket by drilling out the pop rivets.
3. Remove two (2) screws holding interlock switch to hood bracket and remove interlock switch.
4. Disconnect two (2) wires going to hood switch.
5. Connect wires to new hood switch and install.
6. Plug in the balancer.
7. Check to make sure that the motor starts with the hood down, but not with it up.
8. Perform FUNCTION CHECKS.

On/Off Switch Replacement

1. Unplug the balancer.
2. Remove the four (4) bolts from the lower accessory column and remove the cover.

Direct Drive

3. Squeeze the retainers on the switch and push it through the opening in the accessory column.
4. Disconnect wiring to the on/off switch.
5. Connect wires to the new switch and install into the column.
6. Install lower accessory column cover and plug in balancer.
7. Perform FUNCTION CHECKS.

Circuit Breaker Replacement

1. Unplug the balancer.
2. Remove the lower accessory column cover.
3. Remove the two (2) screws to the circuit breaker.
4. Squeeze the retainers on both sides of the circuit breaker and push it through the accessory column.
5. Install new circuit breaker. Connect wires.
6. Install lower accessory column cover.
7. Plug in balancer.
8. Perform FUNCTION CHECKS.

Power Supply Board Replacement

1. Unplug the balancer.
2. Remove weight tray and weight tray shield.
3. Disconnect the Power Supply connector from the main harness.
4. Disconnect the Powers Supply from the Motor Control board at P6.
5. Disconnect Chassis ground.
6. Compress the (4) plastic standoffs, and carefully remove the board.
7. Replace defective board and reinstall in reverse order.
8. Plug in balancer and perform FUNCTION CHECKS.

Note: This board contains a 2.5 amp, 250V fuse which can be replaced if blown. However, if the fuse does blow there could be some other problem with the machine. Make sure to follow all trouble shooting procedures after replacing a board.

Motor Controller Board Replacement

1. Unplug the balancer.
2. Remove weight tray and weight tray shield.

3. Disconnect the incoming power from T1 of the MC board. If single phase, disconnect the capacitor from P4 of the MC board.

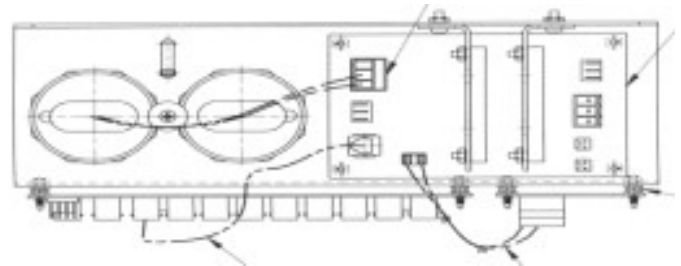

4. Disconnect the CONTROL from P3.
5. Disconnect the power supply from P6.
6. Disconnect the fan motor from P1.
7. Disconnect the motor from P2.
8. Unscrew both SSR's from the power panel.
9. Disconnect switch from P5.
10. Disconnect the Interlock switch from P7 (only models after 12/22/97).
11. Compress plastic standoffs and carefully remove the board.
12. Replace defective Motor Controller Board and reinstall in reverse order.
13. Install weight tray and weight tray shield and plug in balancer.
14. Perform FUNCTION CHECKS.

CPU Board Replacement

1. Unplug the balancer.
 2. Disconnect the Power Supply Board from P10 of the CPU.
 3. Disconnect the RS232 cable.
- Caution! If this cable is not plugged in or does not have a good connection after repair, you will get a WARNING message.**
4. Remove all other phone type cables: CONTROL, HOOD, ENCODER, and PIEZOS.
 5. Compress plastic (5) standoffs and carefully remove the board.
 6. Replace defective CPU Board and reinstall in reverse order.
 7. Plug in the balancer.
 8. Perform FUNCTION CHECKS.

Note: The CPU board contains a replaceable E-PROM chip for software revision. This chip should be replaced in conjunction with the E-Prom chip on the display board, unless specified by the manufacturer.

Direct Drive

Fan Motor Assembly Replacement

1. Unplug the balancer.
2. Remove weight tray and weight tray shield.
3. Disconnect fan motor plug from P1 of the Motor Controller Board.
4. Remove rear end bell cover.
5. Remove the two (2) nuts holding the fan motor to the drive motor and remove the fan motor assembly.
6. Install new fan motor assembly and tighten nuts.
7. Connect fan motor plug to P1 of the Motor Controller Board.
8. Install weight tray and weight tray shield and plug in balancer.
9. Perform PRELIMINARY INSPECTION & FUNCTION CHECKS.

Rotary Shutter Replacement

1. Unplug the balancer.
2. Remove weight tray and weight tray shield.
3. Remove rear end bell cover.
4. Remove the 3/8 by 3/8 shoulder bolt and the rotary shutter.

Note: Some motors will have a plastic shim, part number 8-143988 between the motor and the rotary shutter. Leave this shim in place when replacing the rotary shutter.

5. Install the new rotary shutter.
6. Put Loctite 242 or equivalent on the 3/8 shoulder bolt threads, install and tighten.
7. Install rear end bell cover.
8. Install weight tray and weight tray shield and plug in balancer.
9. Perform FUNCTION CHECKS.

Optical Encoder Assembly Replacement

1. Unplug the balancer.
2. Remove weight tray and weight tray shield.
3. Remove rear end bell cover.
4. Remove rotary shutter.
5. Disconnect optical encoder cable from the CPU Board.
6. Slide optical encoder from aluminum rear end bell casting.

Note: Some motors will have a plastic shim behind the optical encoder. Leave this shim in place when replacing the optical encoder.

7. Install new optical encoder.
8. Install rotary shutter.
9. Install rear end bell.
10. Connect optical encoder cable to the CPU Board.
11. Perform FUNCTION CHECKS.
12. Install weight tray and weight tray shield and plug in balancer.

Drive Motor Assembly Replacement

1. Unplug the balancer.
 2. Remove weight tray, weight tray shield and motor cover.
 3. Disconnect fan motor from the Motor Controller Board.
 4. Disconnect optical encoder cable from the CPU Board.
 5. Disconnect motor wires from P2 of the Motor Controller Board.
 6. Remove the four (4) piezo springs and piezo spring retainers.
 7. Remove the two (2) 1/2 - 18 X 1 washer head screws and washers, lift out the motor assembly.
 8. Position the motor on its side or back and remove the four (4) 3/8 - 16 washer head screws holding the flex plate to the motor.
 9. Remove the flex plate.
 10. Remove the four (4) 3/8 - 16 washer head screws holding the cradle to the motor.
 11. Remove the cradle from the motor.
 12. Apply Loctite 242 to the threads of the 3/8 -16 washer head screws and install the cradle on the new motor.
 13. Clean and apply Loctite to the surface of the flex plate and the cradle where they mate.
 14. Apply Loctite 242 to the threads of the 3/8 - 16 washer head screws and install the flex plate on the cradle.
 15. Ensure balls are inserted into each piezo assembly.
 16. Make sure the piezo ball protectors are installed over the piezo balls (see piezo replacement procedures if replacing new PIEZOS or balls).
 17. Install motor.
 18. Install 1/2 - 18 X 1 washer head screws holding flex plate to chassis.
- Caution! Make sure both washers are perfectly aligned before tightening the bolts, misalignment could cause motor interference.**
19. Install piezo springs, piezo retainers and 3/8 - 16 nyloc nuts.

Direct Drive

20. Tighten the nyloc nuts until the distance from the top of the motor cradle to top of the piezo spring retainer is two (2) inches.

21. Connect fan motor to P1 of the Motor Controller Board.

22. Connect optical encoder cable, and piezo cables to the CPU Board.

23. Connect drive motor plug to P2 of the Motor Controller Board.

24. Install the weight tray, weight tray shield and motor cover and plug in the balancer.

Caution! Always make sure there is nothing touching the motor or motor housing. This can affect weight readings.

25. Perform FUNCTION CHECKS.

Note: Always check the adjustment of the Left Front threaded piezo/motor rod. This adjustment is critical to the correct operation of the A & D arm. It should be adjusted so that the tip is 5.75 inches from the motor plate.

Faceplate & Shaft Assembly Replacement

Note: This procedure should be performed by Authorized Hennessy service personnel. Improper installation could result in damage to the motor shaft which would require a new MOTOR ASSEMBLY!

1. Remove the old faceplate assembly.

2. Clean the contacting surfaces of the motor shaft and inside the faceplate assembly with a soft cloth.

3. Check the runout of the shaft at two points, A & B. the runout should not exceed .0006 (6 ten thousandths) at either point. If runout exceeds this measurement, see MOTOR REPLACEMENT.

4. Slide the six inch socket head bolt (included with new assembly) and the Allen wrench into the shaft. **HAND TIGHTEN!**

5. Attach the torque wrench. Hold the faceplate with one hand to keep from slipping. Tighten to 20 ft./lbs.

Caution! DO NOT OVER TIGHTEN! Over tightening will result in damage to the motor shaft.

6. Check the runout on the faceplate. The runout should not exceed .002. Check the shaft on the inside portion (behind the threads). This runout should not exceed .001 (1 thousandths).

7. If the runout is excessive, loosen socket head bolt and rotate the faceplate assembly 90 degrees (1/4 turn) relative to the witness mark on the motor and retighten. Repeat until minimum results are achieved.

Piezo Assembly Replacement

Note: The piezo assemblies used in the IBS 2000 are different from the other Coats balancers in that they have a 6 pin phone cable connector instead of a wire and spade connector.

1. Unplug the balancer.

2. Remove weight tray, weight tray shield and motor cover.

3. Remove the four (4) 3/8 - 16 Nyloc spring retaining nuts, spring retainers and piezo springs.

4. Remove the two (2) 5/16 - 18 X1 washer head screws.

5. Disconnect the fan motor and optical encoder connections.

6. Disconnect cables to piezo assemblies.

7. Lift up on the motor, twist and lift the piezo assemblies to remove from the chassis.

Caution! Always plug piezos in before loading the motor. If the piezos are plugged after the motor is loaded it could discharge the electricity and short out the LCD BOARD.

Note: Before replacing a piezo assembly:

- Refer to the **PIEZO OUTPUT** test.
- Always check the connecting cables.
- Clean piezo balls with emery cloth (or replace with new balls) and reinstall with **AMMCO gel and plastic protectors.**

8. Use emery cloth to clean the mounting surfaces of the piezo assemblies and chassis, install new piezo assemblies and connect cables.

9. Install the two (2) 5/16 - 18 X1 washer head screws.

10. Install piezo springs, spring retainers and Nyloc nuts.

11. Tighten the Nyloc nuts until the distance from the top of the motor cradle to the top of the retainer is two (2) inches.

12. Connect the fan motor plug to P2 of the Motor Controller Board.

13. Connect the optical encoder cable and the piezo cables.

14. Install weight tray, weight tray shield, motor cover and plug in balancer.

15. Perform **BALANCER CALIBRATION** and **ARM CALIBRATION**.

16. Perform FUNCTION CHECKS.

Direct Drive

Capacitor Assembly Replacement

1. Unplug the balancer.
2. Remove weight tray and weight tray shield.
3. Disconnect plug to capacitor assembly from P4 of the Motor Controller.

Caution! Discharge stored electricity from capacitor before proceeding.

4. Remove the screw and washer holding the capacitors inside the panel.
5. Install new capacitor assembly.
6. Connect plug to P4 of the Motor Controller.
7. Install weight tray, weight tray shield and plug in balancer.
8. Perform PRELIMINARY INSPECTION and FUNCTION CHECKS.

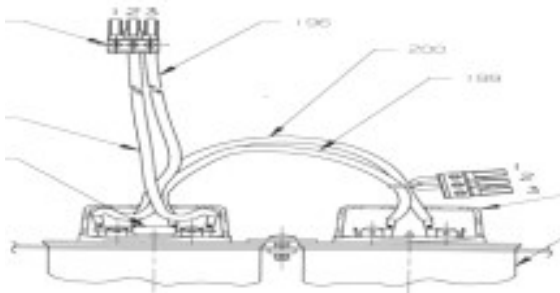

Note: Only one capacitor should have a resistor connected across its terminals. If both new capacitors have resistors, cut one out.

Signal Harness Replacement

1. Unplug the balancer.
2. Remove weight tray and weight tray shield.
3. Remove TOUCH PANEL assembly.
4. Disconnect plugs from TOUCH PANEL assembly.
5. Disconnect signal harness connections inside chassis.
6. Pull harness through the chassis, then out through the accessory column and through the pod tube.
7. Install new signal harness.
8. Connect signal harness connections inside chassis.
9. Connect plugs to TOUCH PANEL assembly.
10. Install TOUCH PANEL assembly.
11. Install weight tray and weight tray shield.
12. Perform BALANCER CALIBRATION and ARM CALIBRATION.
13. Perform FUNCTION CHECKS.

A/D Arm Repair And Replacement

The IBS 2000 uses an automatic Distance A and Diameter D Gauge Assembly, however it is different from the 1050. The arm assembly is repairable and you should refer to the A & D Arm Exploded Parts View in this section, and illustrated parts list in this manual for individual parts identification.

A/D Arm Replacement

Important! Arm Calibration And Balancer Calibration Must be performed after any repair to the A/D arm.

1. Unplug the balancer.
2. Remove weight tray and weight tray shield.
3. Disconnect the A/D arm cable from P7 (Inner Arm) of the CPU Board.
4. Remove the screw and nut from handle assembly and slide it off.
5. Loosen the four (4) Allen head screws from the arm bracket and take off the cover. Note the locating pin in the lower bracket.
6. Slide the arm back so it clears the cabinet and remove, note the locating hole in the arm rod.
7. Install new or repaired gauge assembly.
8. Connect cable to P7 (Inner Arm) of the CPU Board.
9. Plug in the balancer.
10. Perform "A & D Arm Calibration Procedure".
11. Install weight tray and weight tray shield.
12. Perform ARM CALIBRATION and BALANCER CALIBRATION.
13. Perform FUNCTION CHECKS.

Caution! The potentiometers in this machine, unlike potentiometers in other machines, are a three turn pot. Do not attempt to turn past the built in stop or you will destroy the potentiometer.

Note: A bad potentiometer can be detected by looking at the A/D Arm Calibration screen where the voltages are displayed. As the pot is turned the voltage should increase or decrease steadily. If it skips a range(s), the potentiometer is defective and should be replaced.

A Gear Assembly Replacement

Note: The A Potentiometer Adjustment procedure is included in the section.

1. Unplug the balancer.

Direct Drive

- 2.** Remove the weight tray and weight tray shield.
- 3.** Unplug the arm cable from P7 (Inner Arm) of the CPU board.
- 4.** Loosen the clamp screw and remove the plastic arm housing.
- 5.** Disconnect the A pot from the Arm PCB (Distance).
- 6.** Rotate the arm out so the A gear and set screw are positioned on top.
- 7.** Loosen the set screw with an Allen wrench and slide the gear off.
- 8.** Loosen the 1/2" retaining nut on the A pot shaft, and slide the pot out.
- 9.** Reinstall in reverse order. Do not completely tighten the set screw in the A gear until the pot is adjusted properly.
- 10.** Adjust the A pot with a screw driver or pot tool until it is within the appropriate range. Refer to the ARM CALIBRATION procedures.
- 11.** Perform ARM CALIBRATION and BALANCER CALIBRATION.
- 12.** Perform FUNCTION CHECKS.

Small D Gear Assembly Replacement

Note: The D Potentiometer Adjustment procedure is included in this section.

- 1.** Unplug the balancer.
- 2.** Remove the weight tray and weight tray shield.
- 3.** Unplug the arm cable from P7 (Inner Arm) of the CPU board.
- 4.** Loosen the clamp screw and remove the plastic arm housing.
- 5.** Disconnect the D pot (Diameter) from the Arm PCB.
- 6.** Loosen the set screw in the D gear with an Allen wrench. Pull the arm subassembly back enough so the small D gear clears the large D gear. Slide the gear off.
- 7.** Loosen the 1/2" retaining nut on the D pot and slide the pot out.
- 8.** Reinstall in reverse order.
- 9.** Adjust the D pot by sliding the arm sub assembly back so the small gear clears the large D gear.
- 10.** Rotate the small gear until it is within the appropriate range. Refer to the ARM CALIBRATION procedures.
- 11.** Perform ARM CALIBRATION and BALANCER CALIBRATION.
- 12.** Perform FUNCTION CHECKS.

Large D Gear Replacement

- 1.** Unplug the balancer.
- 2.** Remove the weight tray and weight tray shield.
- 3.** Disconnect the arm cable from P7 (Inner Arm) of the CPU board.
- 4.** Loosen the screw on the clamp and remove the plastic arm housing.
- 5.** Remove the screw and nut from the handle assembly and slide it off.
- 6.** Loosen the four (4) Allen head bolts from the arm bracket and remove the bracket cover.
- 7.** Slide the arm sleeve (with the large D gear on it) off the arm rod.
- 8.** Remove the three (3) gear retaining screws.
- 9.** Remove the large D gear and flange bearing.
- 10.** Replace large D gear and reinstall in reverse order.
- 11.** Adjust D pot within tolerance. See SMALL D GEAR REPLACEMENT.
- 12.** Perform ARM CALIBRATION and BALANCER CALIBRATION.
- 13.** Perform FUNCTION CHECKS.

A/D Arm Subassembly Replacement

- 1.** Unplug the balancer.
- 2.** Remove weight tray and weight tray shield.
- 3.** Follow the steps for A/D ARM REPLACEMENT.
- 4.** Loosen the clamp screw and remove the plastic arm housing.
- 5.** Remove the screw and retaining washer from the back of the arm rod.
- 6.** Remove the spring.
- 7.** Follow the instructions for the A GEAR & POT. REPLACEMENT.
- 8.** Follow the instructions for the D GEAR & POT. REPLACEMENT.
- 9.** Slide the subassembly casting and flange bearing off the arm rod.
- 10.** Install new subassembly and reinstall in reverse order.
- 11.** Adjust A & D pots.
- 12.** Perform ARM CALIBRATION and BALANCER CALIBRATION.
- 13.** Perform FUNCTION CHECKS.

Direct Drive

Parts Identification

IBS 2000 Parts Illustration

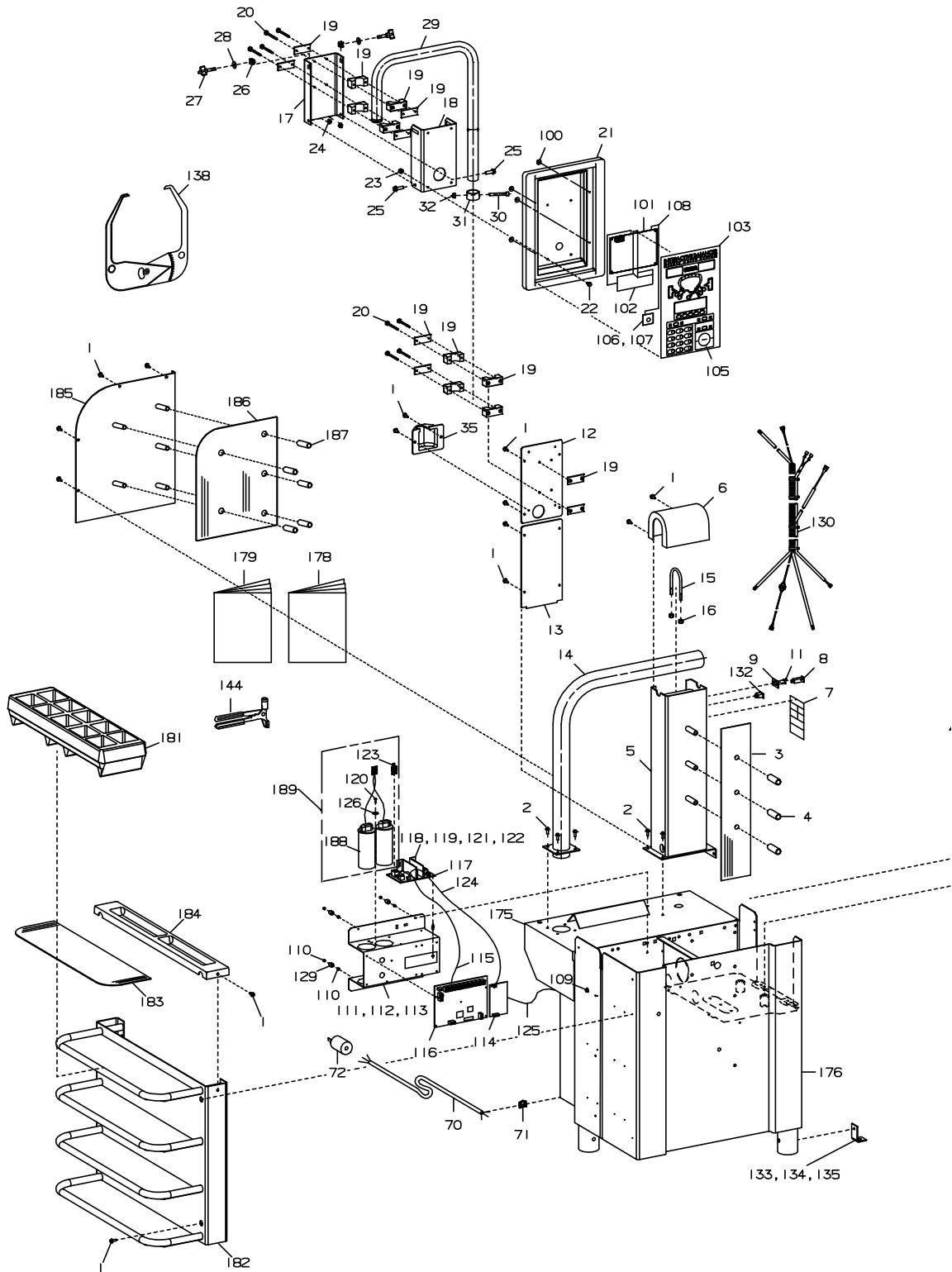

Direct Drive

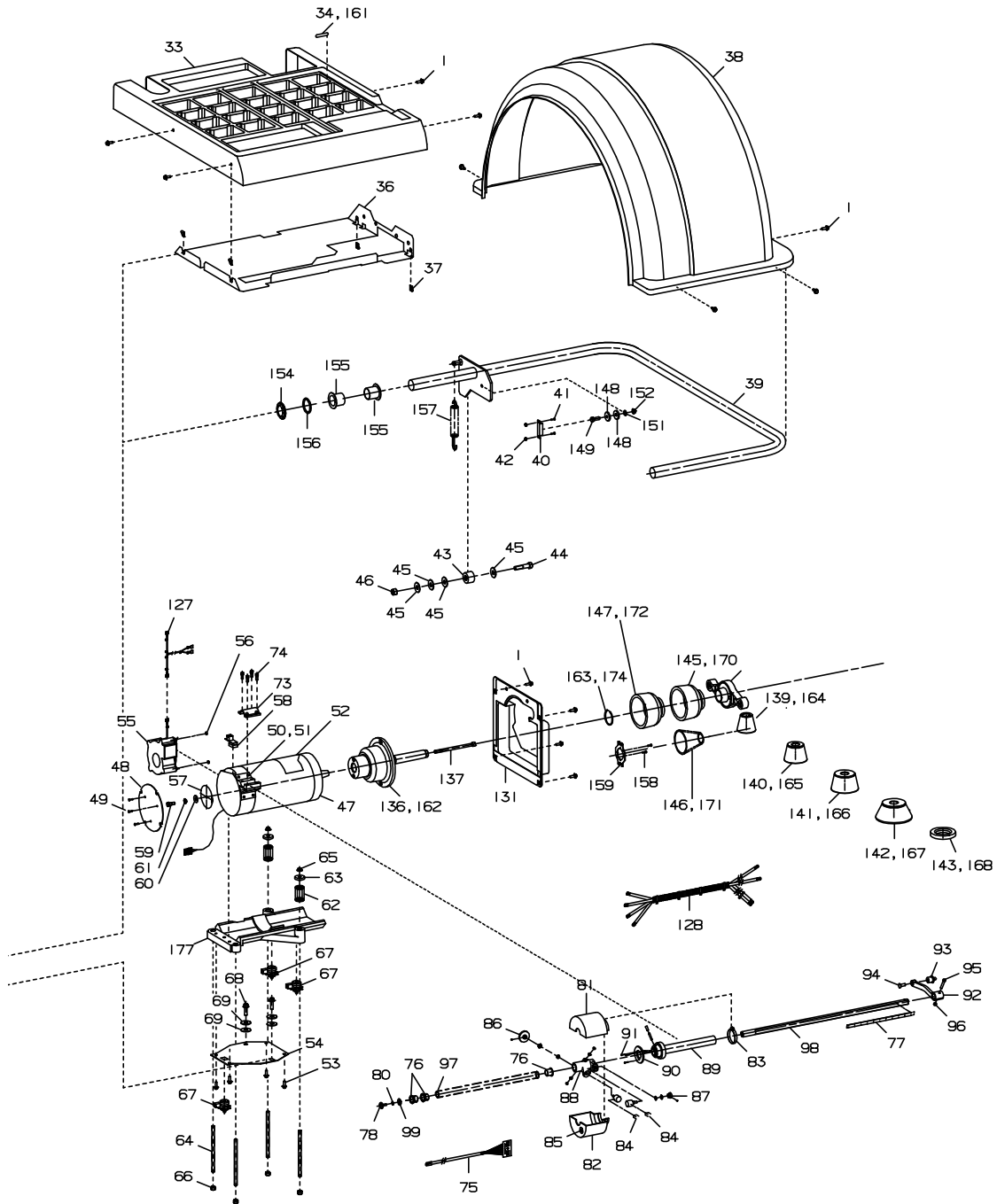

Direct Drive

ITEM	PART NO.	DESCRIPTION	ITEM	PART NO.	DESCRIPTION
1	8106301	1/4-20 St-Hhcs	50	8112329	Assembly, Distance Gauge Mount
2	8108852	3/8-16 St-Hhcs	51	8112054	Screw, 1/4-28 X 5/8" Lg Shcs
3	8112122	Rubber Protector, Cone Storage	52	8112332	Label, Top Dead Center
4	8112060	Sleeve, Accessory Peg	53	8106302	3/8-16 Hhcs
5	8112128	Painted Column	54	8112182	Flex Plate
6	8112154	Cover, Column	55	8112153	Fan Assembly, 230 Vac
7	8112185	Caution/Patent Decal	56	8301084	#8 Kep Nut
8	8111059	Circuit Breaker, 1 Amp	57	8308817	Disk, Encoder
9	8112194	Assembly, Circuit Breaker Mounting Plate	58	8112215	Assembly, Optical Encoder
11	8111542	#8-32 X 5/8 Lg Phms Bx	59	8301016	Bolt, 3/8 X 3/8 Shoulder
12	8112019	Upper Column Cover	60	8301032	3/8 Washer, Flat
13	8112159	Lower Column Cover	61	8104200	3/8 Washer, Internal Lock
14	8112187	Assembly, 2.5" Tube	62	8307008	Spring, Piezo
15	8110789	U Bolt 2.5" Tube	63	8308036	Retainer, Piezo
16	8181183	5/16-18 Lock Nut	64	8108727	Rod, Threaded Piezo
17	8112027	Bracket, Pod Mounting	65	8301033	Nut, 3/8 Jam
18	8112028	Bracket, Pod Adjustment	66	8106303	Nut, 3/8-16 Whiz Lock
19	8112029	Clamp, Pod Tube	67	8112203	Piezo Assembly
20	8112179	1/4-20 X 3" Lg Hhcs	68	8120325	5/16-18 Whhcs
21	8112030	Pod, Plastic	69	8301121	1/2 Washer, Flat
22	8143168	1/4-20 Wh Screw	70	8112318	Cord, Power
23	8143169	1/4-20 Wh Nut	71	8150128	Relief, Power Cord Strain
24	8301035	3/8-16 Hh Lock Nut	72	8140786	Plug, Electrical 230v 3" Only
25	8106302	3/8-16 Wl Hhcs		8305076	Plug, Electrical 230v 1" Only
26	8143044	3/8-16 Hh Tinnerman Nut	73	8112053	A/D Arm Clamp
27	8110817	Knob, 3/8-16 Thrd	74	8112054	112054 1/4-28 X 5/8 Lg Shcs
28	8301032	3/8 Flat Washer	75	8112205	112205 Cable, Modular A&D Arm
29	8112032	1.5" Dia Pod Tube	76	8112058	Bushing
30	8112176	3/8-16 X 2 1/2" Lg Shcs	77	8112148	Scale, Distance Gauge
31	8112175	Tube, Pod Locator	78	8106301	1/4-20 St-Hhcs
32	8106303	3/8-16 Wh Nut	80	8301142	1/4 Lock Washer
33	8112034	Assembly, Weight Tray, Plastic	81	8112118	Housing, Left A/D Arm
34	8112036	Labels, Weight Tray	82	8112115	Housing, Right A/D Arm
35	8112178	Cover, Rear Harness	83	8112120	Clamp, Large
36	8112038	Shield, Weight Tray	84	8112059	Assembly, Potentiometer
37	8106304	1/4-20 Tinnerman Clip	85	8112249	Strain Relief, Modular Cable
38	8112040	Wheel Guard, Plastic	86	8112062	Gear, "A"
39	8112041	Weldment, Hoodbar	87	8112061	Gear, "D" Small
40	8305050	Switch, Reed	88	8112056	Sub Assembly, A&D Body
40a	8111820	Interlock Switch	89	8112067	Sub-Assembly, A/D Arm Sleeve
41	8301063	#6-32 Phms	90	8112071	Gear, Large "D"
42	8301066	#6 Kep Nut	92	8112074	Handle, A/D Arm
43	8309008	Stop, Molded Hood	93	8112139	Tip, Distance Gauge
44	8301120	1/2-13 X 2.5" Lg Hhcs	94	8112140	5/16-18 X 7/8" Lg Fhms
45	8301121	1/2 Washer	95	8112141	1/4 - 20 X 1 1/2" Lg Bhms
46	8301122	1/2-13 Lock Nut	96	8181369	1/4-20 Nylon Insert Locknut
47	8112233	Motor Assy Wired	97	8112075	Spring, A/D Arm
48	8308513	Cover, Rear End Bell	98	8112077	Machined Complete, A/D Arm Rod
49	8112191	#10-24 X 1/2" Lg Hhms	99	8111032	Washer, Fender 1/4 Bx-1050
			100	8111055	#6 Lock Nut

Direct Drive

ITEM	PART NO.	DESCRIPTION	ITEM	PART NO.	DESCRIPTION
101	8112079	Display Pcb	152	8106303	3/8-16 Wh Nut
102	8112220	Lcd Display	154	8109945	Retainer, Hood Tube
103	8112225	Touch Panel Sub Assembly	155	8307014	Bearing, Flanged
105	8308017	Rubber Plunger, Black	156	8109944	Hood Washer
106	8301063	#6-32 Phms	157	8112048	Spring, Hood
107	8112219	Manual Start Pcb Assembly	158	28590	#10-24 X 1/2" Lg Phms, Phillips
108	8112248	Cable Assy	159	8112110	Bracket, Captive Back Cone
109	8110560	Ground Screw (Green)	161	8112142	Gram Decal Sheet
110	8112317	#10-32 Kep Nut	162	8112097	Face Plate/Stub Shaft 40mm Id
111	8112237	Bracket - Assy Power Panel	163	8110514	Retainer, Pressure Cup 1.125
112	8112208	Plastic Standoff	164	8112098	Cone, Small 40 Mm Id
113	8301084	Kep Nuts #8-32	165	8112099	Cone, Medium 40 Mm Id
114	8112081	Power Supply	166	8112100	Cone, Large 40 Mm Id
115	81122001	Cable Assy	167	8112101	Adapter, Large 40 Mm Id
116	8112082	Main Cpu Board	168	8112102	Ring, No Mar 40 Mm Id
117	8112083	112083 Motor Controller	169		
118	8112223	Heat Sink	170	8112103	Nut, Hub 40 Mm Id
119	8301063	#6-32 Phms	171	8112107	Spring, Back Cone 40 Mm Id
120	8301092	#8-32 X 1/2" Lg Phms	172	8112106	Pressure Cup 40 Mm Id
121	8301066	6-32 Nut	174	8112114	Retainer, Pressure Cup
122	3420	#6 Washer	175	8112132	Painted Weight Tray Support
123	8112224	Wiring - Jumper For 3 Phase	176	8112001	Chassis, Painted
124	8112207	Wiring Assy P.S. To Motor Control	177	8110430	Motor Cradle/Dampner - Assembly
125	8112319	Wire Assembly, Ground	178	8111537	Coats Accessory Catalog
126	8112236	Capacitor Washer	179	8112095	Owners Manual
127	8112240	Wire Assy - Fan	181	8112268	Sliding Weight Tray
128	8112209	Wiring Harness, Chassis	182	8112260	Accessory Side Tray
129	8112084	Vibration Isolators	183	8112190	Rubber Shelf Pad
130	8112206	Wiring Harness, Pod	184	8112255	Plastic Cover, Side Tray
131	8112161	Motor Cover /Shield Assembly	185	8112196	Panel Assembly, Pod Tube Backing
132	8305802	Switch, On/Off	186	8112189	Pad - Panel Pod Tube Backing
133	8112091	Machine, Hold Down	187	8112199	Sleeve, Accessory Peg
134	8109950	3/8 Washer, Flat Nylon	188	8112356	Capacitor, Assembly 230v, 1" Only
135	8112152	3/8-16 X 1 1/4 Lg Whcs	189	8112352	Capacitor Kit
136	8112129	Assembly, Face Plate/Stub Shaft 1.125 Id	190	8112120	Large Clamp
137	8112121	3/8-16 X 6"Lg Shcs	**	8112414	Magnet
138	8309011	Wheel Calipers	**	8112415	Magnet Spacer
139	8112167	Cone, Small 1.125 Id	**	8112373	Switch Cover
140	8112168	Cone, Medium 1.125 Id			
141	8112169	Cone, Large 1.125 Id			
142	8112170	Adapter, Large 1.125 Id			
143	8308105	Ring, No Mar 1.125 Id			
144	8111515	Tool, Wheel Weight			
145	8110543	Nut, Hub 1.125 Id			
146	8308820	Spring, Back Cone 1.125 Id			
147	8110542	Pressure Cup 1.125 Id			
148	8109947	Magnet, Hood Stop			
149	8111447	5/16-18 Nylon Bolt			
151	8109950	3/8 Washer, Flat Nylon			

Note: ** used on models with interlock switch produced as of 1/98

Direct Drive

IBS 2000 Wiring Diagrams

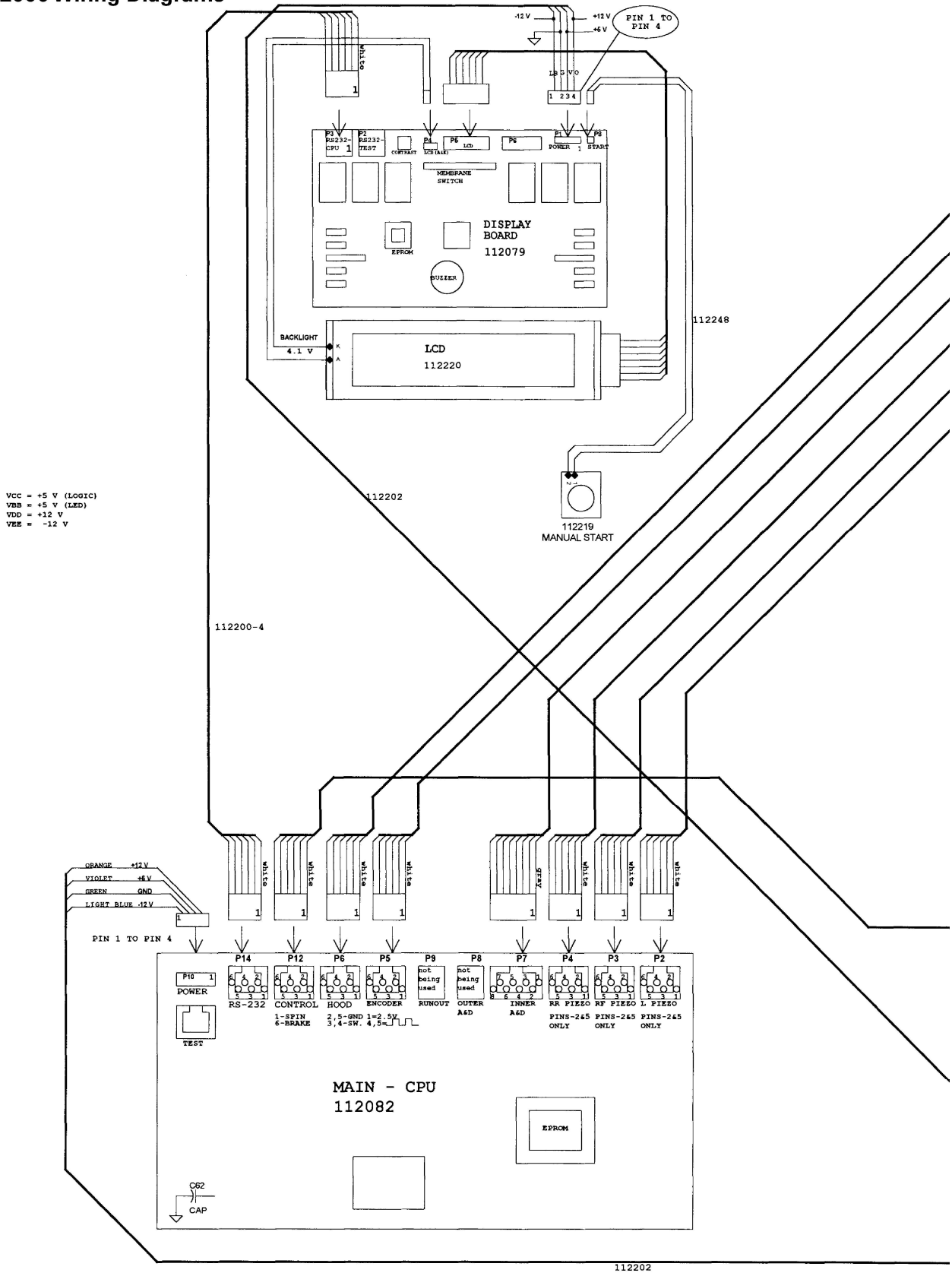

Direct Drive

REVISION				
SUM	CHG	REV	DATE	BY
0			RELEASE	17198

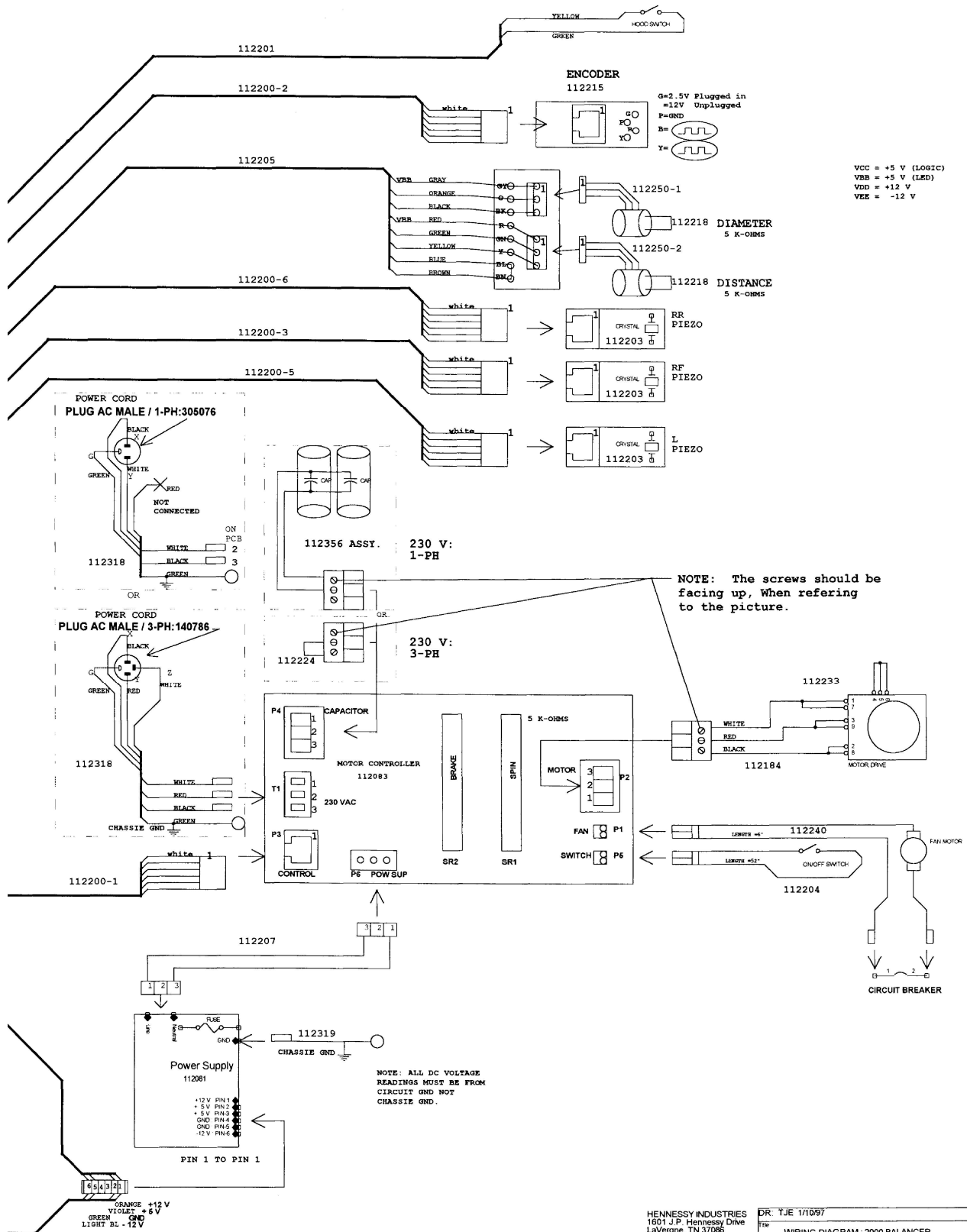

HENNESSY INDUSTRIES
 1601 J.P. Hennessy Drive
 LaVerne, TN 37086
 PH. 615-641-7533

DR: TJE 1/10/97
File: WIRING DIAGRAM - 2000 BALANCER
Size: B Document Number: 112368 Rev: 0
Date: Friday, May 29, 1997 Sheet: 1 of 1

Direct Drive

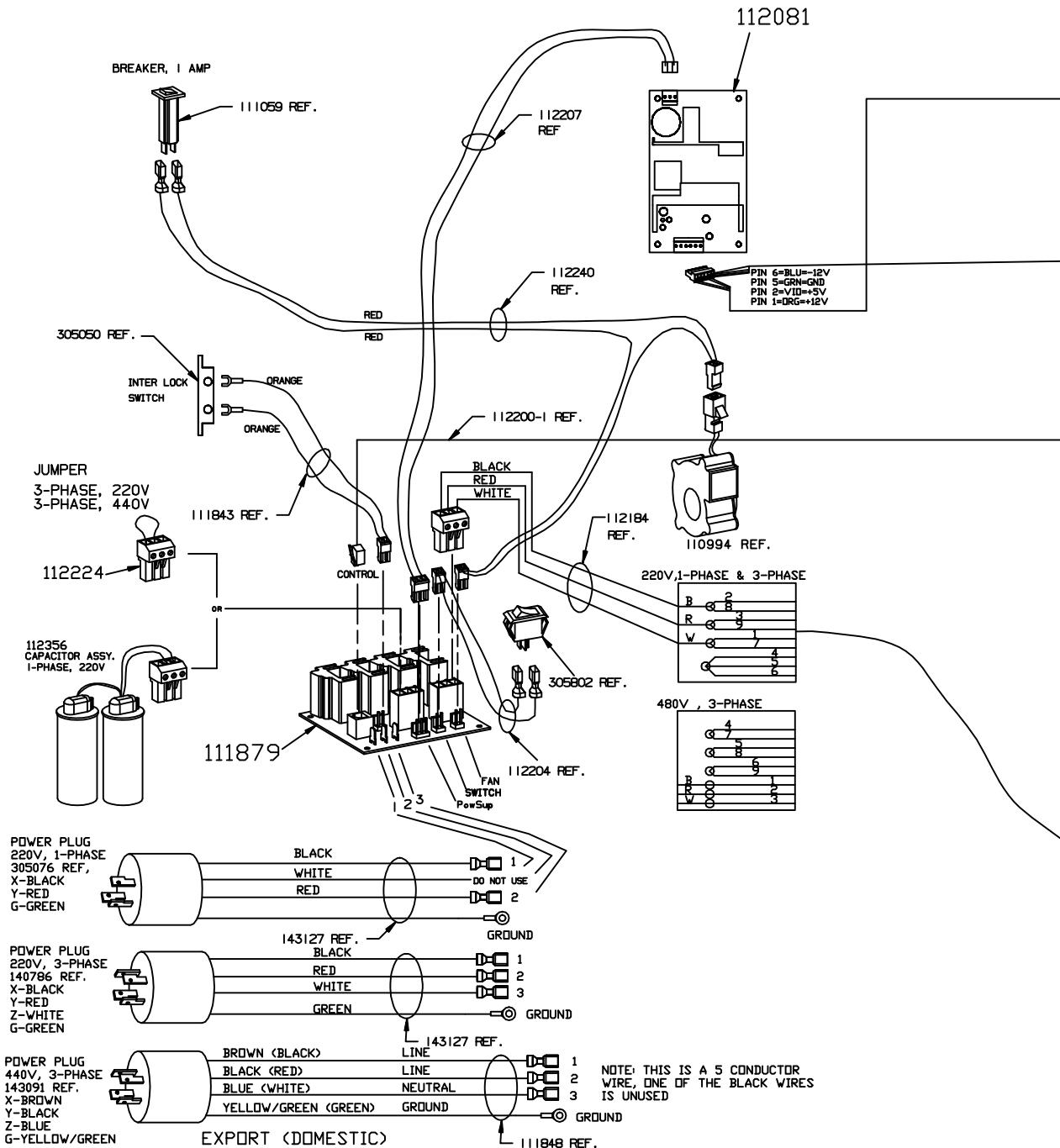

Direct Drive

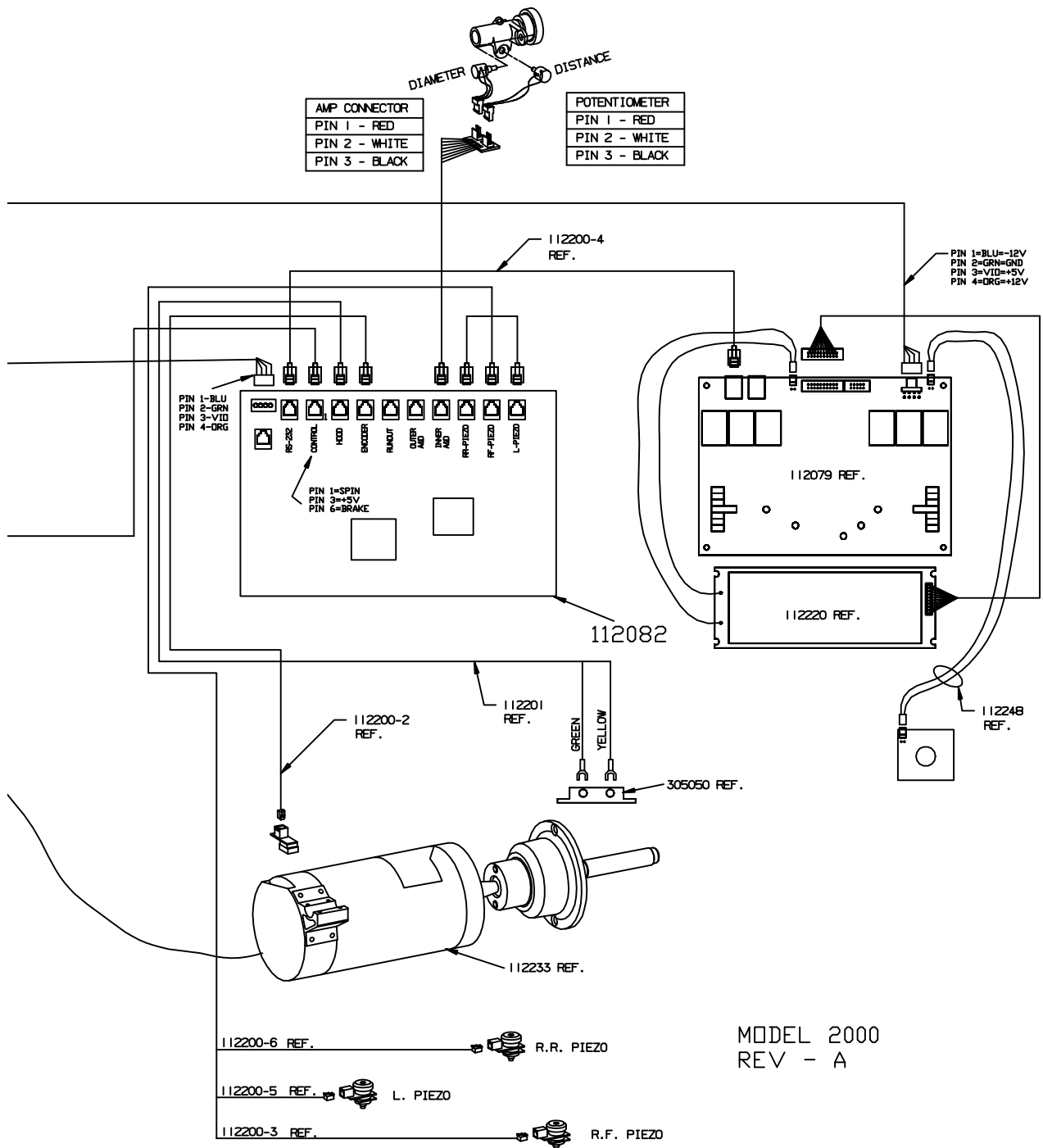

MODEL 2000
REV - A

