

COATS®

XR 1800/1850 Series Wheel Balancer

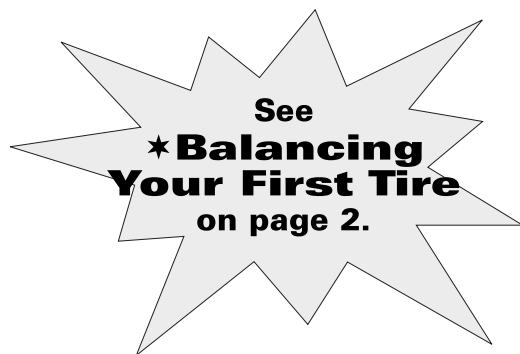

Installation Instructions Operating Instructions Safety Instructions Maintenance Instructions

READ these instructions before placing unit in service KEEP these and other materials delivered with the unit in a binder near the machine for ease of reference by supervisors and operators.

HENNESSY INDUSTRIES, INC.

1601 J. P. Hennessy Drive, LaVergne, TN USA 37086-3565 615/641-7533 800/688-6359 www.ammcoats.com
HENNESSY INDUSTRIES INC. Manufacturer of AMMCO®, COATS® and BADA® Automotive Service Equipment and Tools.

Manual Part No.: 8113423 07
Revision: 01/07

Safety

IMPORTANT SAFETY INSTRUCTIONS

READ ALL INSTRUCTIONS

1. Eye and face protection recommendations:
“Protective eye and face equipment is required to be used where there is a reasonable probability of injury that can be prevented by the use of such equipment.” O.S.H.A. 1910.133(a) Protective goggles, safety glasses, or a face shield must be provided by the owner and worn by the operator of the equipment. Care should be taken to see that all eye and face safety precautions are followed by the operator. ALWAYS WEAR SAFETY GLASSES. Everyday glasses only have impact resistant lenses, they are not safety glasses.
2. Do not disable hood safety interlock system, or in any way shortcut safety controls and operations.
3. Be sure that wheels are mounted properly, the hub nut engages the arbor for not less than four (4) turns, and the hub nut is firmly tightened before spinning the wheel.
4. Read and understand this manual before operating. Abuse and misuse will shorten the functional life.
5. Be sure the balancer is properly connected to the power supply and electrically grounded.
6. Do not operate equipment with a damaged cord or if the equipment has been dropped or damaged – until it has been examined and repaired by a qualified serviceman.
7. Do not let cord hang over edge of table, bench, or counter or come in contact with hot manifolds or moving fan blades.
8. If an extension cord is necessary, a cord with a current rating equal to or more than that of the equipment should be used. Cords rated for less current than the equipment may overheat. Care should be taken to arrange the cord so that it will not be tripped over or pulled.
9. Keep guards and safety features in place and in working order.
10. Wear proper clothing. Safety toe, non-slip footwear and protective hair covering to contain hair is recommended. Do not wear jewelry, loose clothing, neckties, or gloves when operating the balancer.
11. Keep work area clean and well lighted. Cluttered and/or dark areas invite accidents.
12. Avoid dangerous environments. Do not use power tools or electrical equipment in damp or wet locations, or expose them to rain.
13. Avoid unintentional starting. Be sure the balancer is turned off and power disconnected before servicing.
14. Disconnect the balancer before servicing.
15. Use only manufacturer’s recommended accessories. Improper accessories may result in personal injury or property damage.
16. Repair or replace any part that is damaged or worn and that may cause unsafe balancer operation. Do not operate damaged equipment until it has been examined by a qualified service technician.
17. Never overload or stand on the weight tray or any part of the balancer.
18. Do not allow untrained persons to operate machinery.
19. To reduce the risk of fire, do not operate equipment in the vicinity of open containers or flammable liquids (gasoline).
20. Adequate ventilation should be provided when working on or operating internal combustion engines.
21. Keep hair, loose clothing, fingers, and all parts of body away from moving parts.
22. Use equipment only as described in this manual.
23. Use only manufacturer’s recommended attachments and accessories.

SAVE THESE INSTRUCTIONS

Safety

Owner's Responsibility

To maintain machine and user safety, the responsibility of the owner is to read and follow these instructions:

- Follow all installation instructions.
- Make sure installation conforms to all applicable Local, State, and Federal Codes, Rules, and Regulations; such as State and Federal OSHA Regulations and Electrical Codes.
- Carefully check the unit for correct initial function.
- Read and follow the safety instructions. Keep them readily available for machine operators.
- Make certain all operators are properly trained, know how to safely and correctly operate the unit, and are properly supervised.
- Allow unit operation only with all parts in place and operating safely.
- Carefully inspect the unit on a regular basis and perform all maintenance as required.
- Service and maintain the unit only with authorized or approved replacement parts.
- Keep all instructions permanently with the unit and all decals/labels/notices on the unit clean and visible.
- Do not override safety features.

Operator Protective Equipment

Personal protective equipment helps make tire servicing safer. However, equipment does not take the place of safe operating practices. Always wear durable work clothing during tire service activity. Loose fitting clothing should be avoided. Tight fitting leather gloves are recommended to protect operator's hands when handling worn tires and wheels. Sturdy leather work shoes with steel toes and oil resistant soles should be used by tire service personnel to help prevent injury in typical shop activities. Eye protection is essential during tire service activity. Safety glasses with side shields, goggles, or face shields are acceptable. Back belts provide support during lifting activities and are also helpful in providing operator protection. Consideration should also be given to the use of hearing protection if tire service activity is performed in an enclosed area, or if noise levels are high.

Definitions of Hazard Levels

Identify the hazard levels used in this manual with the following definitions and signal words:

DANGER

Watch for this symbol:



It Means: Immediate hazards, which will result in severe personal injury or death.

WARNING

Watch for this symbol:



It Means: Hazards or unsafe practices, which could result in severe personal injury or death.

CAUTION

Watch for this symbol:



It Means: Hazards or unsafe practices, which may result in minor personal injury or product or property damage.



Watch for this symbol! It means BE ALERT! Your safety, or the safety of others, is involved!

Safety

Safety Notices and Decals



Failure to follow danger, warning, and caution instructions may lead to serious personal injury or death to operator or bystander or damage to property. Do not operate this machine until you read and understand all the dangers, warnings and cautions in this manual. For additional copies of either, or further information, contact:

Hennessy Industries, Inc.

1601 J.P. Hennessy Drive
LaVergne, TN 37086-3565
(615) 641-7533 or (800) 688-6359
www.amccoats.com

The Lateral Runout unit of this machine contains a Class IIIa laser with a maximum output less than 5mW at a wave length of 650-670 nm. **Avoid Exposure - Laser radiation is emitted from its aperture.**



Use of controls, adjustments or performance of procedures other than those specified herein may result in hazardous radiation exposure.

There are NO service procedures or adjustments which can be performed on the laser in this product.

In case of failure, the entire lateral runout unit (part no. 80180126) must be replaced.



This product, incorporating a laser, has been tested to the requirements of CDRH 21CFR and complies with standards 21CFR1040.10 and 21CFR1040.11

Hennessy Industries, Inc.
1601 J.P. Hennessy Drive
LaVergne, TN 37086

Manufactured:

8113909 01

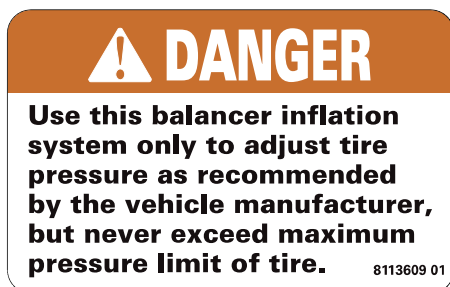

Safety

⚠ WARNING
Risk of Injury
This machine is provided with a wheel guard interlock. Do not defeat it's purpose.
8111840 02

⚠ WARNING
Maximum Size of Wheel Rating
Weight Diameter Width
160 lbs. 44 in. 20 in.
Maximum Duty Cycle
30 Wheels/Hour @ 160 lbs.
8113570 01

Standard Safety Devices

- Stop key for stopping the wheel under emergency conditions.
- A hood guard of high impact plastic that is designed to prevent the counterweights from flying out in any direction except towards the floor.
- A hood switch interlock system that prevents the machine from starting if the guard is not lowered and stops the wheel whenever the guard is raised.

⚠ WARNING
RISK OF EXPLOSION
This equipment has internal arcing or sparking parts which should not be exposed to flammable vapors. Do not locate in a recessed area or below floor level.
THIS EQUIPMENT MUST BE EARTH-GROUNDED
The earth-ground connector built into the power cord provides protection to reduce the risk of electrical shock.

⚠ CAUTION
Do not use below garage floor or grade level.
Disconnect power before servicing this equipment.
To prevent electrical shock, do not remove cover. No user serviceable parts inside. Refer servicing to qualified service personnel.

May Be Protected by one or more of the following patents:
USA - 4,423,632 - 4,499,768 - 4,939,941 - 5,311,777 - 5,337,256
AUSTRALIA - 564038

8113547 01



⚠ CAUTION
Connect only to 115 V, 60 HZ,
7 A, 1 PHASE power supply. 8113553 01

⚠ CAUTION
115 V, 60 HZ, 7 A, 1 PHASE
MAX. RECEPTACLE 8113551 00

Safety

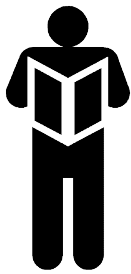

NOTICE

Read entire manual before assembling, installing, operating, or servicing this equipment.

Contents

Table of Contents

Important Safety Instructions	ii	Mounting Wheel on Spindle Shaft24 - 25
Owner's Responsibility	iii	Standard Back Cone Mounting24
Operator Protective Equipment	iii	Standard Front Cone Mounting25
Definitions of Hazard Levels	iii	Alternate Mounting25
Safety Notices and Decals	iv - v	Machine Self-calibration and	
Standard Safety Devices	v	Service Adjustments26 - 29
★Balancing Your First Tire2 - 3	Machine Self-calibration26
Principle Operating Parts4 - 9	Service Adjustments27
Power Switch6	Distance Arm Calibration27
Air Gauge Panel6	Width Sonar Calibration (If equipped)27 - 28
Positioning Pedal6	Diameter Arm Calibration (Plastic)28
Using the Offset Arm7	Diameter Arm Calibration (Metal)29
Sensor Measuring Systems8	Diagnostic Procedures29 - 34
Printer9	After Balance Vibration Problems29
Understanding the		Troubleshooting30 - 33
Video Display Screens10 - 13	Machine Self-Test "Green Screen"34
Monitor and Initial Screen Feature Reference11	Maintenance Instructions35
Menu Screen Flowchart12 - 13	Monitor Screen Adjustment35
Balancer Function		Installation Instructions36 - 37
Set-up and Review14 - 16	Receiving36
General Set-up14 - 15	Electrical Requirements36
★Balancing Set-up15	Setup36
Special Functions15	Air Supply Connection36
Additional Functions16	Connect to Power36
Advanced Balancing Functions16 - 19	Floor and Space Requirements37
Initial Screen Options16 - 17	Specifications38
Dynamic Modes17	Features38
Static Modes18	Required Accessories39
Special Modes18	Optional Accessories39
Additional Options19	Glossary of Terms41
Matching20 - 22	1750/1800 Functional Check for	
Automatic Runout Detection20	CalibrationBack Cover
Optimization (Match Balance)21		
Runout (Runout Match)22		
Manually Setting Wheel			
Dimensions (DIM)23		

Video Balancer

★Balancing Your First Tire

Important: Always read and follow the on-screen operating instructions.

1. Turn the machine OFF then ON (resets machine).

The initial screen is in dynamic mode using standard clip-on wheel weight locations and wheel dimensions.

2. Mount a tire/wheel on the balancer that will use standard clip-on wheel weights.

Use the most appropriate mounting method.

3. Always remove any weights already attached to the wheel.

Use the most appropriate mounting method. Always remove any weights attached to the wheel.

4. Enter A & D wheel dimensions using offset arm.

For Automatic Measurement — pull the offset arm out to the wheel, hold it still at clip-on weight position against the wheel flange, and wait for the BEEP.

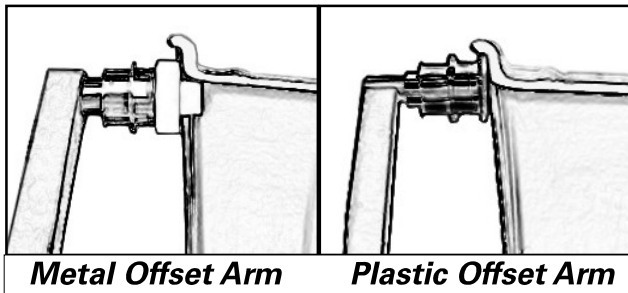

Figure 1 - Automatic Measurement

Clip-on Weight Location — viewed on a cut-away rim for clarification.

5. Enter Width wheel dimension.

Enter Width at DIM screen or, if equipped with the Hood Sensor System, lower the hood to automatically measure tire width.

6. The wheel spins and unbalances are measured and displayed.

The corrective weight amount appears on the video display screen for the left and the right planes of the wheel, see figure 3.

7. Raise hood after tire stops rotating.

Note: If the hood is raised before the end of the spin, an error screen will appear. Wait for the weight amounts to display before raising the hood.

8. Rotate wheel to position left side placement arrow at the center bar.

As illustrated in figure 3, rotate the wheel to position the left side placement arrow at the center red bar. Step on the positioning pedal to hold the tire in place.

9. Attach left side corrective weight amount at top-dead center on the inside flange of the wheel.

Attach specified corrective weight amount (0.25 oz in figure 3) at top-dead-center on inside flange of wheel.

10. Rotate wheel to position right side placement arrow at center bar.

Rotate the wheel to position the right side placement arrow at the center red bar. Step on the positioning pedal to hold the tire in place.

11. Attach the right side corrective weight.

Attach specified weight amount (0.75 oz in figure 3) at top-dead-center on the outside flange of the wheel.

12. Lower the hood to respin the tire/wheel and check balance.

Your weight readings should now be 0.00.

Note: Throughout this manual tire dimensions are referred to as A, W, and D, see figure 2.

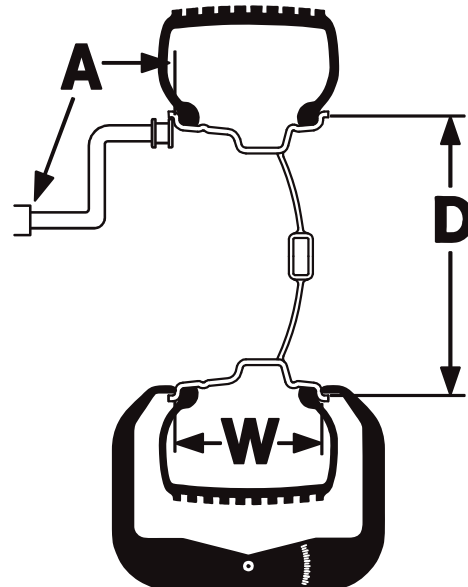

Figure 2 - A, W, and D Tire Dimensions

Video Balancer

Note: To reset the mode back to the initial screen at any time, press the DYNAMIC option **2** or press the **MENU** key, or turn the machine OFF then ON. Note that if an operator is in a balance mode, it may be necessary to finish the balance cycle first.

Important: Always read and follow the on-screen operating instructions.



Figure 3 - Weight Placement Screen Using Clip-on Weights in Dynamic Mode

Video Balancer

Principle Operating Parts

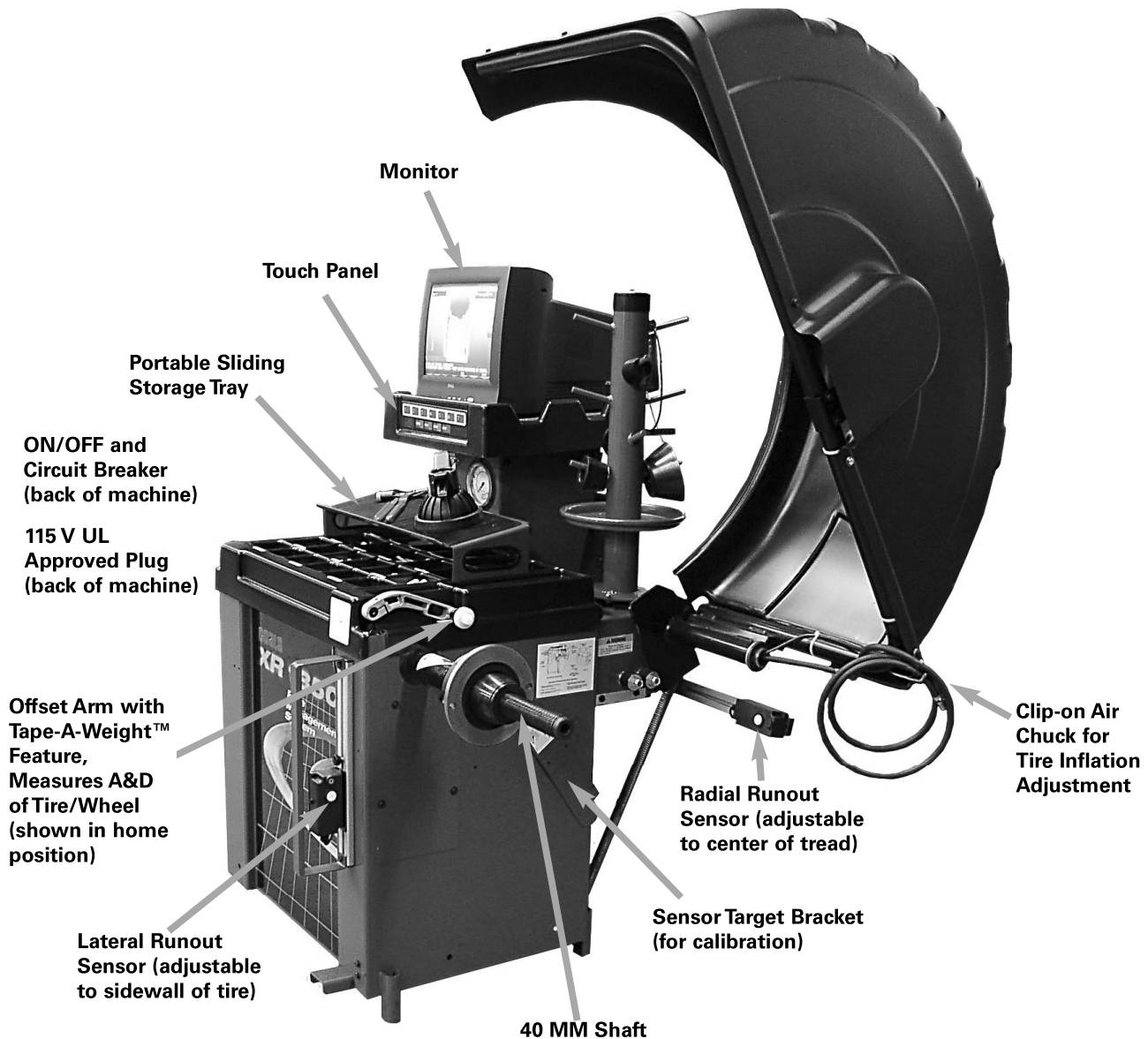

Video Balancer

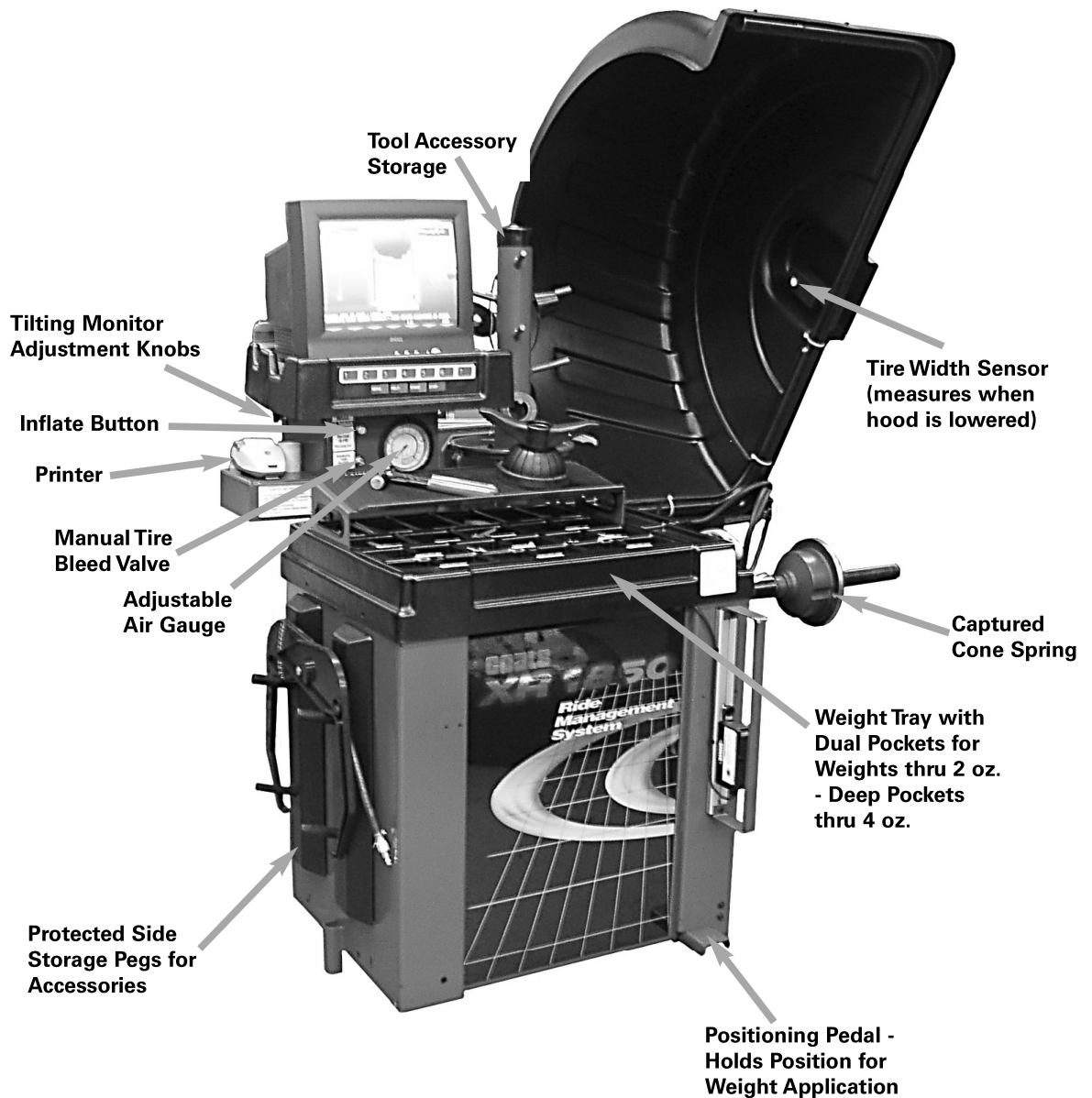

Important: Always read and follow the on-screen operating instructions.

Video Balancer

Power Switch

The ON/OFF decal, see figure 4, indicates the location of the ON/OFF switch at the back of the balancer. The circuit breaker reset button is also at this location.

Air Gauge Panel



NEVER exceed tire manufacturer's recommended air pressure. Tires can explode, especially if inflated beyond these limits. Keep hands, arms, and entire body back from inflating tire. Avoid distraction during inflation. Check tire pressure frequently to avoid over inflation. Excessive pressure can cause tires to explode, causing serious injury or death to operator or bystander.



Do not lower the hood with the clip-on air chuck attached to the tire's valve stem. With the hood start feature ON, the tire will start rotation causing damage to the wheel and balancer and possible personal injury.

As shown, the wheel balancer is equipped with the capability to adjust the air pressure of the tire. The INFLATE push button supplies air through the hose and clip-on air chuck located at the wheel guard. When the chuck is attached to the valve stem, air pressure is indicated on the gauge. Excess pressure can be reduced using the MANUAL TIRE BLEED VALVE. See figure 4.

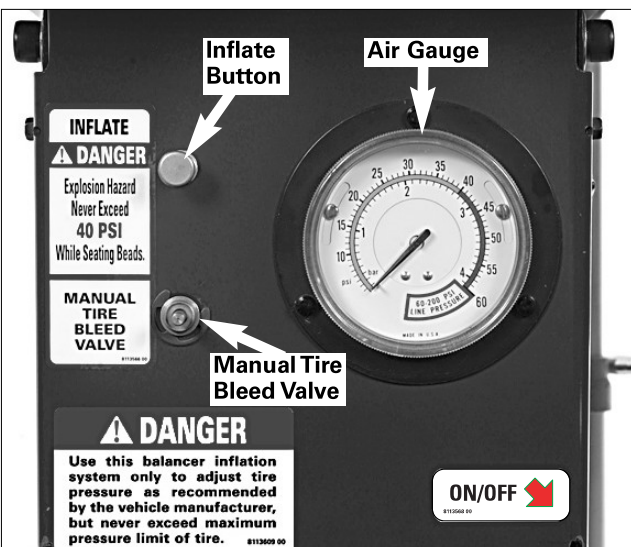

Figure 4 - Air Gauge Panel and ON/OFF switch decal that indicates ON/OFF switch location at the back of the balancer.

Positioning Pedal

Use the positioning pedal to hold the wheel position during weight application, as shown in figure 5.



Do not actuate the positioning pedal during the measurement cycle. Do not use the positioning pedal as a brake.



Figure 5 - Positioning Pedal

Video Balancer

Using the Offset Arm

When prompted by the on-screen instructions, use the offset arm, see figure 6, to enter A & D measurements automatically.



Figure 6 - Offset Arm

To measure for a clip-on weight location, place the offset arm at the wheel flange as shown in figure 7A (metal arm) or figure 7B (plastic arm).

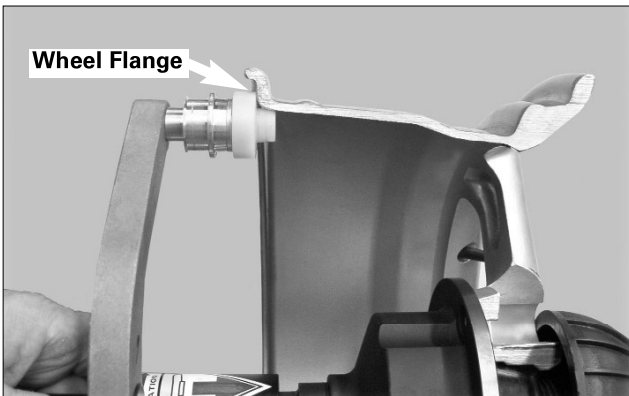

Figure 7A - Clip-on Weight Location Using Metal Offset Arm Viewed on a Cut-Away Rim for Clarification.

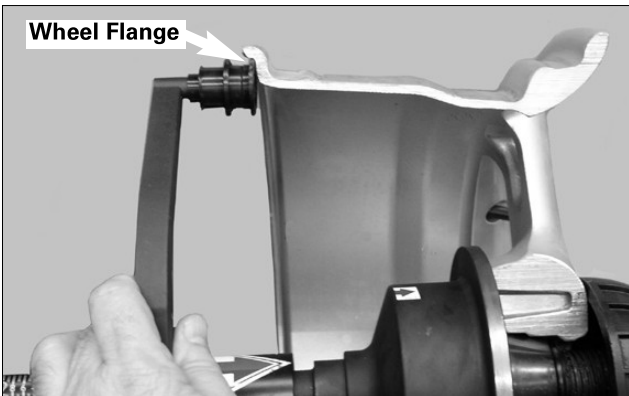

Figure 7B - Clip-on Weight Location Using Plastic Offset Arm Viewed on a Cut-Away Rim for Clarification.

To measure for a hidden weight location, place the offset arm at a hidden weight placement location as shown in figure 8.

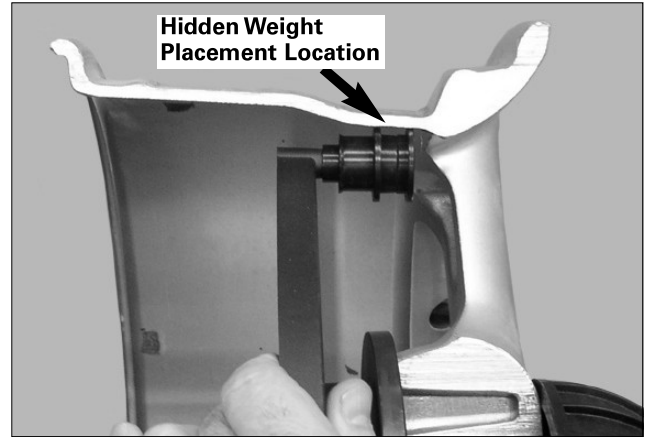

Figure 8 - Hidden Weight Location Viewed on a Cut-Away Rim for Clarification.

Use the offset arm Tape-A-Weight™ feature for accurate placement of hidden weights. See figure 9.



Figure 9 - Hidden Weight Placement Location Viewed on a Cut-Away Rim for Clarification.

Note: Throughout this manual wheel weights are referred to as Clip-on or Tape-A-Weight™ (Hidden Weight). Figure 10 shows an example of each weight.



Figure 10 - Corrective Weight Examples. For Best Results, use BADA® Brand Wheel Weights.

Video Balancer

Sensor Measuring Systems

By lowering the hood, measure wheel width automatically using the Tire Width Sensor. See figures 10 and 11.

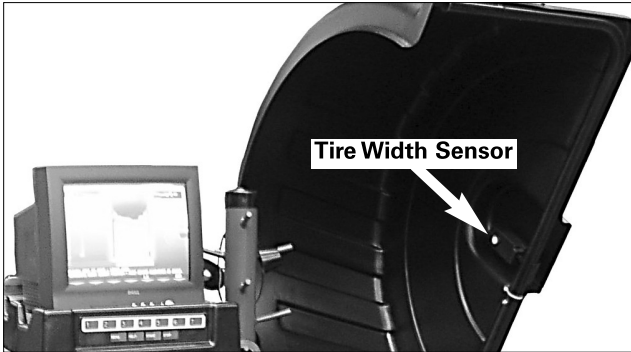

Figure 10 - Tire Width Sensor

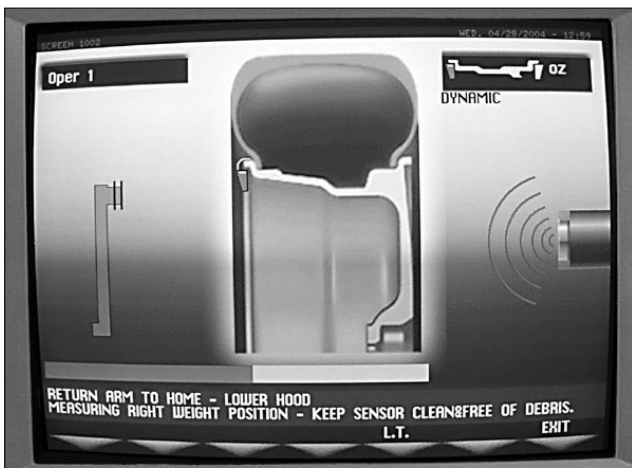

Figure 11 - Screen with Width Sensor Icon

The sensor, shown in figure 12, is mounted on an adjustable slide at rear of machine and is used to measure radial runout of the tire when the eye of the sensor is centered on the tread width.

Important: To activate the radial runout function, press the **MENU** button, select the GENERAL SET-UP option **5**, and set the RUNOUT UNLOADED ⇩ option **7** to SONAR.



Figure 12 - Radial Runout Sensor

The sensor, on especially equipped models, (shown in figure 13) is mounted on an adjustable slide and is used to measure lateral runout of the tire when the eye of the sensor is centered on the flat of the tire side-wall.

Important: To activate the lateral runout function, press the **MENU** button, select the GENERAL SET-UP option **5**, and set the RUNOUT UNLOADED ⇨ option **6** to SONAR.

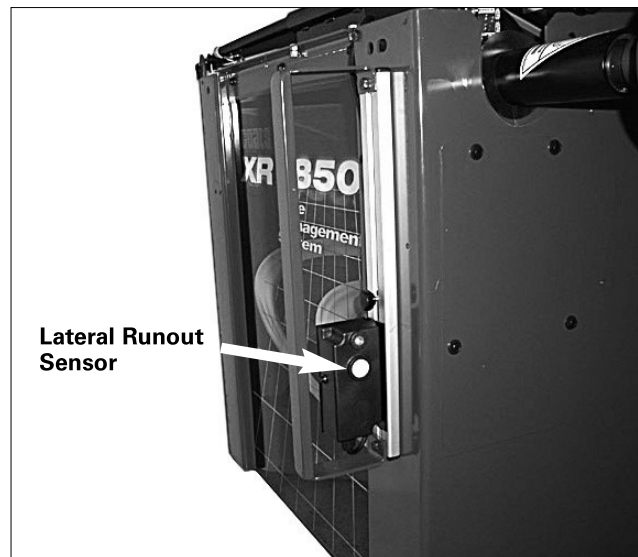

Figure 13 - Lateral Runout Sensor

Video Balancer

Printer

Use the printer, on especially equipped models, (shown in figure 14) to provide a BALANCER CERTIFICATE for the wheel balance service.

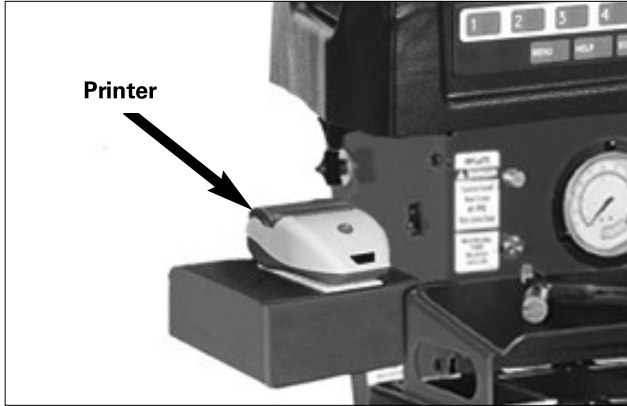
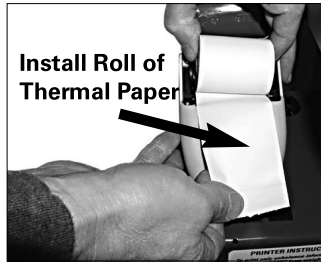

Figure 14 - Printer

Important: The software will not recognize the printer unless there is paper in the printer. This is also the case if the paper is threaded between the paper roller and the printer top cover.



The flashing LED on front of printer indicates power to the printer, but the printer could still be incorrectly connected or out of paper.

Important: To activate the printer function, press the **MENU** button, select the GENERAL SET-UP option **5**, select the PRINTER option **5**, and set the PRINTER option **1** to ON.

Also, toggle ON or OFF the following printer options for the printout (default is ON for all these options):

Option **2** OWNER ADDRESS - prints the owner's address (see page 15 to customize to the machine).

Option **3** SPIN NO. - records the spin no. from CYCLE HISTORY (see page 16 for more information).

Option **4** OPERATOR NO. - indicates the operator number and name (see page 17 to customize to the machine).

Option **5** VEHICLE TAG NO. - provides a space for the operator to write in the vehicle tag number.

Option **6** LOC. ON VEHICLE - operator uses this diagram to manually check the wheel location that was serviced.

Option **7** CORRECTED - operator uses this area to manually check either YES if runout was corrected or N.R. if not required.

On selected screens, to print the BALANCER CERTIFICATE press option **6**. Note that the printout option **7** CORRECTED is only available for RUNOUT DIAGNOSTIC (see MATCHING on page 20 for more information).

BALANCER CERTIFICATE

HENNESSY IND. INC.
1601 J.P. HENNESSY DR.
LaVERGNE, TN.
XR1850
DATE: 01/22/2004

SPIN NO. 29
OPERATOR NO. 1
VEHICLE TAG NO.

AZF-1850

UNBAL. READINGS
INNER PL. OUTER PL.
0.000z 0.000z

LOC. ON VEHICLE

RADIAL R.O.
ASSEMBLY - 0.059"
RIM - 0.006"
TIRE - 0.059"
% CORR. - 10
CORRECTED:
 YES N.R.

LATERAL R.O.
ASSEMBLY - 0.022"
CORRECTED:
 YES N.R.

Figure 15 - Completed Printer Balancer Certificate

Video Balancer

Understanding the Video Display Screens

The video display screens provide access to functions, options, and on-screen instructions for the operator. See figure 19 for the Monitor and Initial Screen Feature Reference.

1. Access additional functions by pressing one of the following four keys, at the bottom of the monitor.



MENU - brings up a menu screen. Press MENU again (toggle) to return to the previous screen.

HELP - provides on-screen help instructions for the current screen.

START - begins a measurement cycle, if the hood is lowered.

STOP - stops a measurement cycle or exits a screen as noted in instructions.

2. To select a screen option, press the numbered key that corresponds with the key icon along the bottom of each video display screen. See figure 16.



Figure 16 - Select an Option by Pressing Its Corresponding Numbered Key

3. Always refer to the screen dialogue area for important operating instructions.



4. Refer to the Mode Icon in the upper right hand corner of the screen for mode and weight placement type.

Mode Icon Examples:



5. An option with the symbol >>> indicates the presence of additional screens. In the example below, press key **1** to view the next screen.

Menu Option Example:

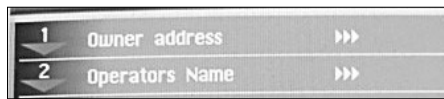

6. At the weight placement screen align the weight placement arrows for correct positioning of hidden weights. See figures 17 and 18.



Figure 17 - Weight Placement Arrows in 3D Mode.



Figure 18 - Weight Placement Arrows in Profile Mode.

Video Balancer

Monitor and Initial Screen Feature Reference

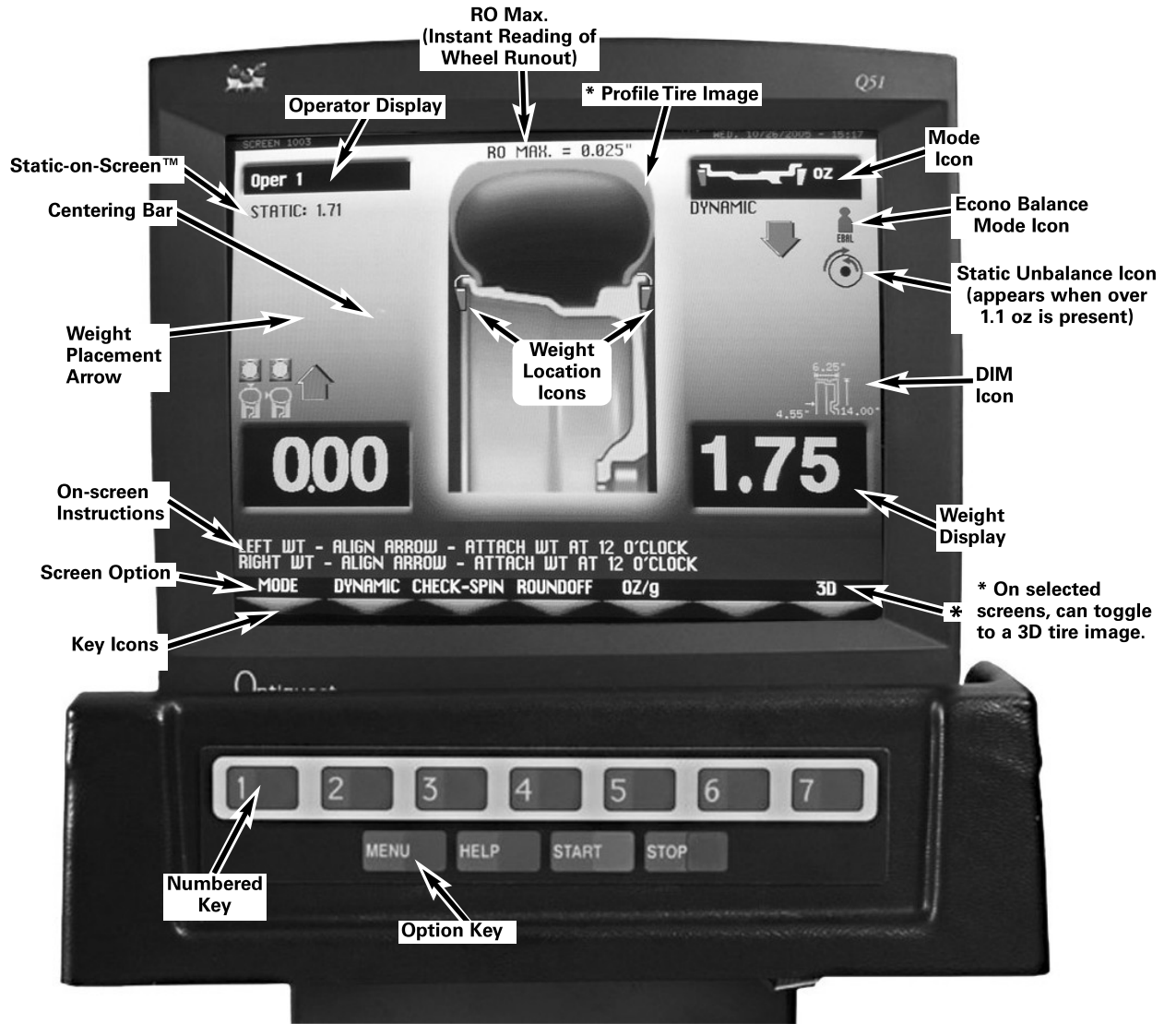
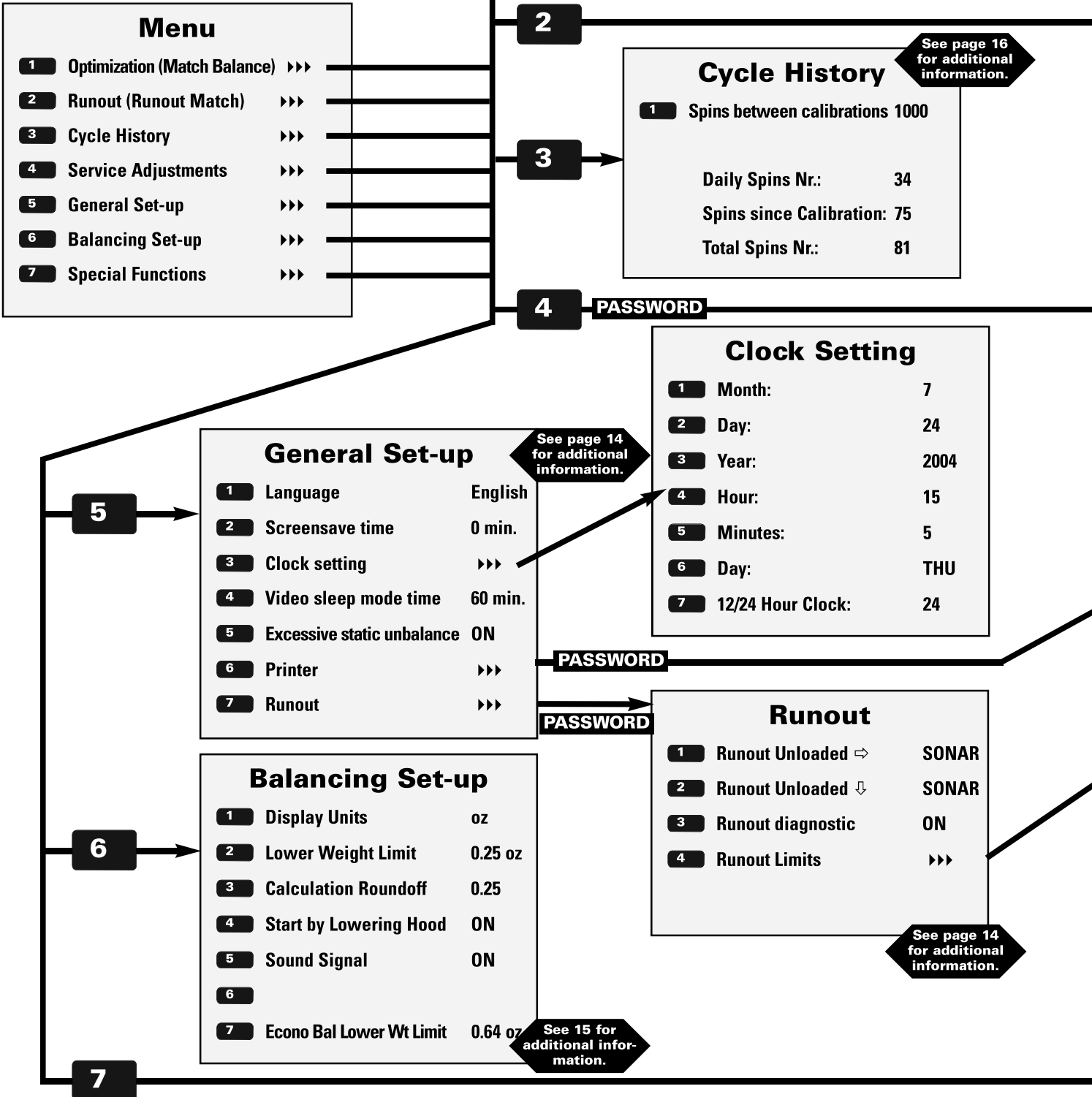

Figure 19 - Monitor and Initial Screen Feature Reference

Video Balancer

Menu Screen Flowchart

Press the **MENU** key for the Menu screen to access balancer function screens and to set configuration screens. See the flowchart below.



Video Balancer

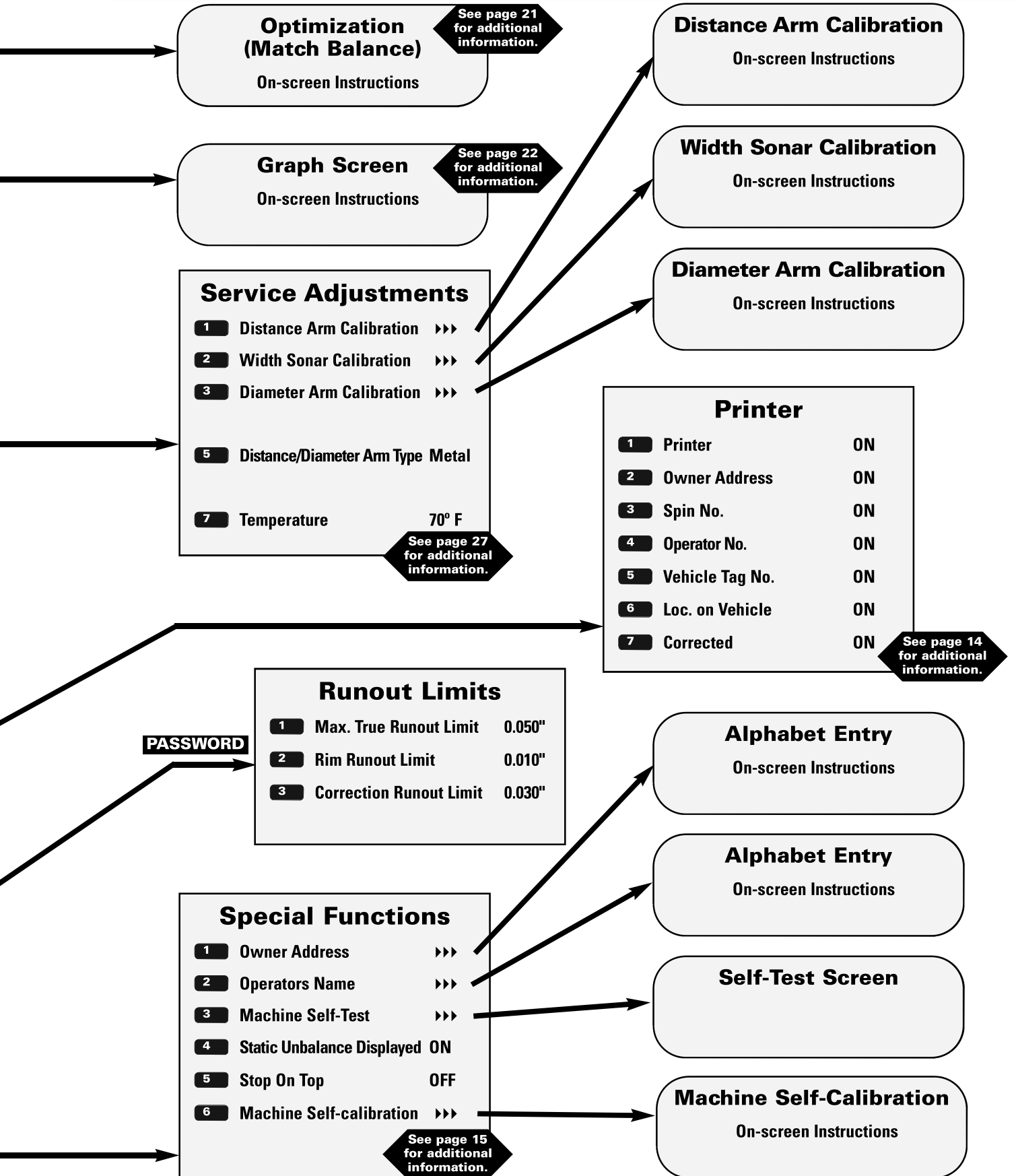

Important: Always read and follow the on-screen operating instructions.

Video Balancer

Balancer Function Set-up and Review

See the Menu Screen Flowchart on page 12 and 13 for screen access information.

* Indicates recommended settings.

General Set-up

Press the **MENU** key and select the GENERAL SET-UP option **5** for the following menu selections.

* Shown with Recommended Settings

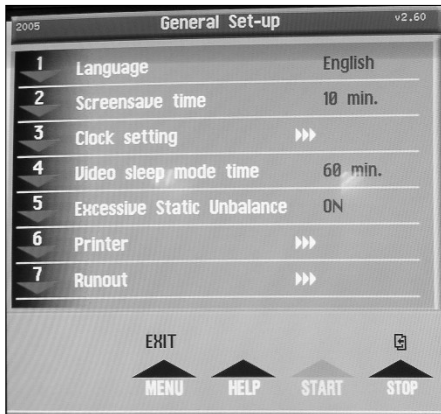

Figure 20 - *General Set-up Screen

- 1** **Language** - Toggle to display English, Español, or Français. * Set to ENGLISH.
- 2** **Screensave time** - Set from 1 to 10 minutes @ 1 minute increments.
- 3** **Clock setting** - Set the month, day, year, hour, minutes, day, and 12/24 hour clock.

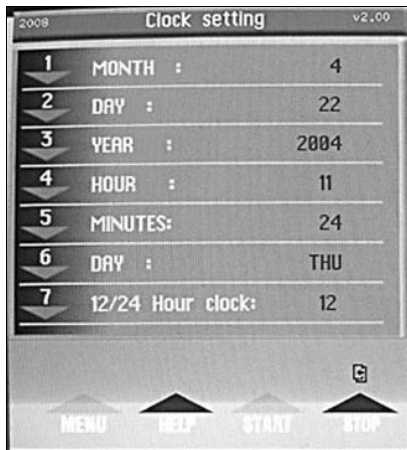

Figure 21 - Clock Setting Screen

- 4** **Video sleep mode time** - Set the range from 0 through 60 minutes. * Set to 60 min.
- 5** **Excessive Static Unbalance** - Toggle ON or OFF to detect whether the static unbalance limit is exceeded. * Set to ON.

- 6** **Printer** - Toggle ON or OFF to set the printer, owner address, spin no., operator no., vehicle tag no., loc. on vehicle, and corrected options.

See PRINTER on page 9 for further details.

* Shown with Recommended Settings

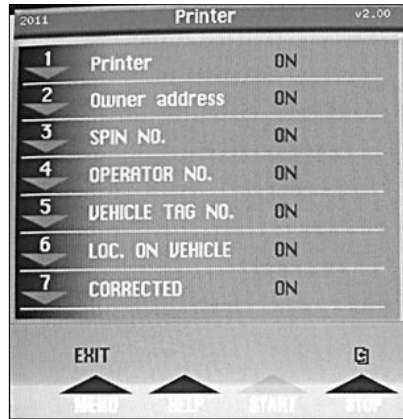

Figure 22 - Printer Screen

- 7** **Runout** - Set runout options from this menu.

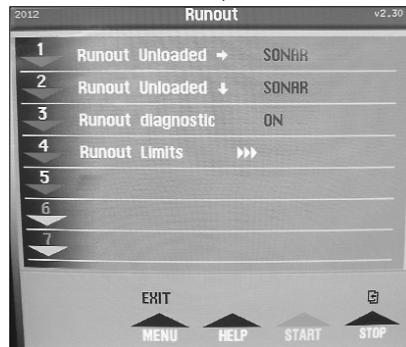

Figure 23A - Runout Screen

- 1** **Runout Unloaded ⇌** - (lateral) toggle to OFF or SONAR. * Set to OFF for the XR 1800 Model! * Set to ON for the XR 1850 Model!
- 2** **Runout Unloaded ↓** - (radial) toggle to set to OFF or SONAR. * Set to SONAR.
- 3** **Runout Diagnostic** - Toggle ON or OFF. See MATCHING pg. 20 for further details.
- 4** **Runout Limits** - Tolerances that indicate the limit of runout allowed on the tire/wheel. Set tolerances within the following range:

Note: See MATCHING on page 20 for further details.

Video Balancer

Select RUNOUT LIMITS option **4** for runout menu:

- 1 Max. True Runout Limit** - Tolerance that indicates the limit of runout allowed on the tire/wheel.
- 2 Rim Runout Limit** - Tolerance that indicates runout limit allowed on rim.
- 3 Correction Runout Limit** - Tolerance that indicates the limit of runout allowed on the tire/wheel.

*** Shown with Recommended Settings**

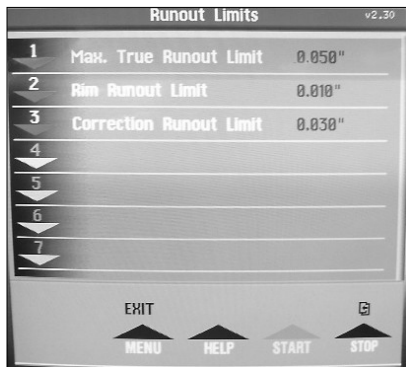

Figure 23B - Runout Limits Screen

Balancing Set-up

Press the **MENU** key and select the BALANCING SET-UP option **6** for the following menu selections.

*** Shown with Recommended Settings**

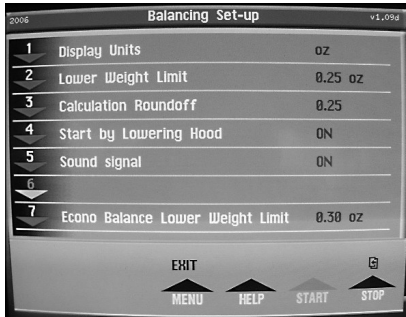

Figure 24 - *Balancing Set-up Screen

- 1 Display Units** - Toggle to set OZ (ounce) or G (gram) weight measurements.
- 2 Lower Weight Limit** - Set the limit within the following tolerances:
0.13 - 0.50 oz (ounces) @ 0.01 increments
4 - 10 g (grams) @ 1 gram increments

Note: The closer the Lower Weight Limit is set to 0.13 oz (4 g) the more respins you will have when attaching 0.25 oz (5 g) weights.

- 3 Calculation Roundoff** - Toggles the display of weight corrections roundoff from 0.25 OZ (most wheels) to 0.50 OZ (heavy wheels).
- 4 Start by Lowering Hood** - Toggle ON or OFF.
- 5 Sound Signal** - Toggle ON or OFF. Enable for an audible beep when a key is pressed, dimensions are acquired (automatic mode), correct weight placement is reached (measurement screen), and correct weight application point is reached (positioning screen).
- 7 Econo Balance Lower Weight Limit** - Set limit within the following tolerances:
0.20 - 0.90 oz (ounces) @ 0.01 increments
4 - 25 g (grams) @ 1 gram increments

Special Functions

Press the **MENU** key and select the SPECIAL FUNCTIONS option **7** for the following menu selections.

*** Shown with Recommended Settings**

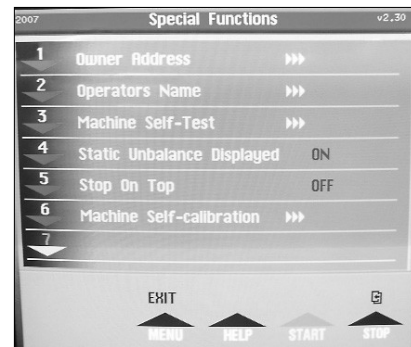

Figure 25 - Special Functions Screen

Customize the machine by following the on-screen instructions for functions **1** and/or **2**.

- 1 Owner Address** - This information appears on the screensaver. It consists of three lines, each a maximum of 30 characters.
- 2 Operators Name** - Enter up to four different machine user names, each a maximum of 15 characters. Follow the on-screen instructions to complete the customization.

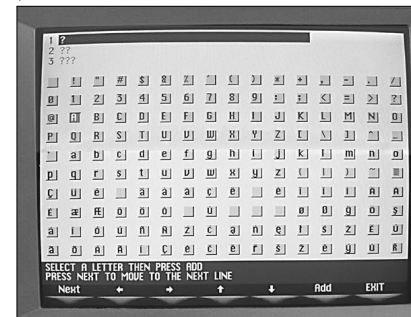

Figure 26 - Operator Name Entry Screen

Video Balancer

- 3 Machine Self-Test** - Provides software version, technical, and other machine diagnostic information (DIAGNOSTIC PROCEDURES section page 34).
- 4 Static Unbalance Displayed** - Toggles the display of the Static-on-Screen™ value ON or OFF. ★ *Set to ON.*
- 5 Stop On Top** - Toggle ON or OFF to automatically stop the wheel near TDC (top-dead-center) for outer weight placement. ★ *Set to OFF.*
- 6 Machine Self-calibration** - Calibrates the weight amount and placement. See MACHINE SELF-CALIBRATION AND SERVICE ADJUSTMENTS on page 26 for more information.

Additional Functions

Press the **MENU** key and select the CYCLE HISTORY option **3** for the following menu.

★ Shown with Recommended Settings

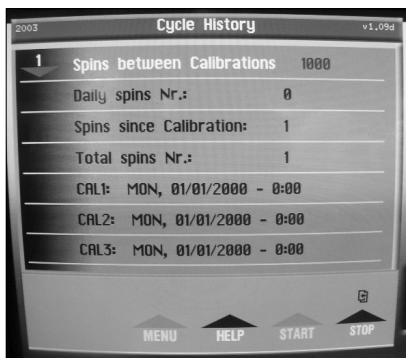

Figure 27 - Cycle History Screen

- 3 Cycle History** - Select option **1** to set the number of spins between calibrations (500 - 5000 @ 500 spin increments).

Also, the operator can view the following information when the CYCLE HISTORY option **3** is selected.

- The number of daily spins that is automatically reset after switching the machine off.
- View the number of spins since calibration.
- View the total number of spins.

Advanced Balancing Functions

This wheel balancer enables you to balance a variety of wheel configurations. Read through this section, it will help you determine which mode and options are best suited for certain wheel assemblies.

Remember: As with any balancing procedure, first remove any weights attached to the wheel, inspect the tire and wheel, and use the most appropriate balancer mounting method before beginning.

Initial Screen Options

At the initial screen (see page 11), press the numbered key that corresponds with the key icon along the bottom of the video display screen for the following options.

- 1 Mode** - select from several balancing types and weight placement locations.

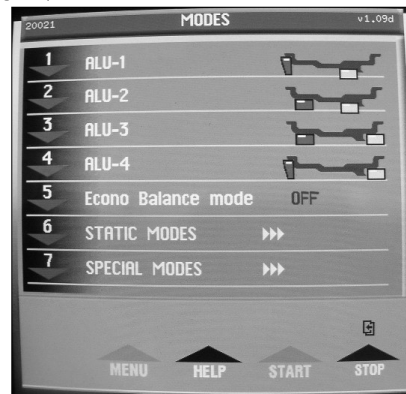

Figure 28 - Modes Screen

- 2 Dynamic** - the "initial screen" is a dynamic balance mode using two clip-on weight locations.

Note: To reset the mode back to the initial screen at any time, press the DYNAMIC option **2**, or turn the machine OFF then ON. Note that if an operator is in a balance mode, it may be necessary to finish the balance cycle first.

- 3 DIM** - (available in 3D view) select to enter dimensions manually. See MANUALLY SETTING WHEEL DIMENSIONS on page 23 for further details.

Video Balancer

- 3 Check-Spin** - press to save 2 to 3 seconds of time when a balancing wheel. This option eliminates the runout measurement during the Check-Spin.
- 4 Roundoff** - toggle between 0.25-ounce or 0.01-ounce weight increments.
- 5 Oper** - (available in 3D view) used to cycle through (recall) an operator's memorized measurements. This wheel balancer can be used simultaneously by four operators. See SPECIAL FUNCTIONS on page 15 for further details.
- 5 OZ/g** - (available in PROFILE view) toggle between ounce or gram weight measurements.
- 6 Printer** - (available in 3D view) prints a certificate with important balancing information. See PRINTER on page 9 for further details.
- 7 Profile or 3D** - Toggle between a profile or 3D tire image for weight placement.

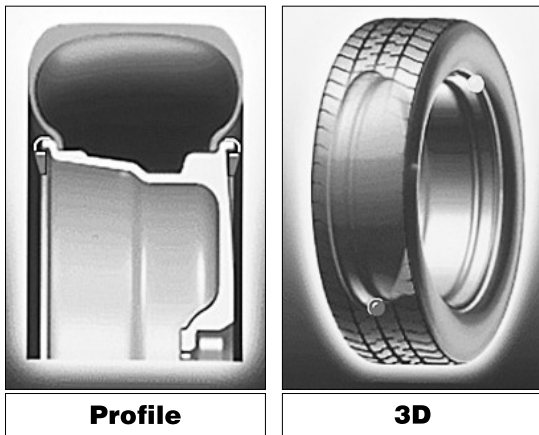

Figure 30 - The Profile and 3D Icons

Dynamic Modes

Clip-on Weights - the initial screen. This mode is used for most passenger and light truck tire assemblies using the most common location for corrective weights. Clip-on weights are placed on the inner and outer rim flanges.

Note: To reset the mode back to the initial screen at any time, press the DYNAMIC option **2**, or turn the machine OFF then ON. Note that if an operator is in a balance mode, it may be necessary to finish the balance cycle first.

Have the following items handy: steel rim passenger or light truck tire wheel assembly mounted on the balancer and clip-on weights.



Figure 31 - Clip-on Weight Placement Screen

ALU modes - Select the MODE option **1** for the modes menu. All the ALU modes are dynamic balance. Choose the option that best fits the available weight locations.

- 1** - ALU-1
- 2** - ALU-2
- 3** - ALU-3
- 4** - ALU-4

Have the following items handy: an appropriate wheel assembly mounted on the balancer and Tape-A-Weights™. You must use the appropriate measurement and weight placement technique for each plane selection (page 7) to balance the wheel.

Video Balancer

Static Modes

Choose a static balance for wheel assemblies that are not possible to balance dynamically or for narrow wheels. For example, a motorcycle wheel that has a small wheel width.

Select the MODE option **1** for the modes menu and then select the STATIC MODES option **6**. Choose the option that best fits the available weight locations.

a. For a "single weight," choose any one plane location.

b. For "two weights," choose any two plane locations. Using this approach can reduce the amount of induced dynamic unbalance by splitting the correctional weight value among two different planes.

- 1** - STATIC1 
- 2** - STATIC2 
- 3** - STATIC3 
- 4** - STATIC4 

Have the following items handy: an appropriate wheel assembly mounted on the balancer and a selection of weights.

Special Modes



Select the MODE option **1** for the modes menu. Select the SPECIAL MODES option **7** to choose a mode for the following special type wheel assemblies.

PAX Balance - Select the appropriate option for the PAX wheel that best fits the available weight locations.

- 1** - PAX1 
- 2** - PAX2 

Have the following items handy: a PAX wheel assembly mounted on the balancer and a selection of Tape-A-Weights™.

Patch Weight Balance - Use a static patch weight balance when there is a very large unbalance in a tire assembly or if a very large tire has a large unbalance. A weighted balance pad (patch weight) is placed inside the tire in the center to compensate for the large unbalance.

- 3** - PATCH (static) 
- 4** - DIAMETER ↑ 

Have the following items handy: measuring tape and various patch weight sizes.

Note: Before proceeding with Patch Weight Balance, it is recommended that you use the Optimization (Match Balance) procedure first, see page 21, in order to use the smallest patch weight.



The Patch Weight Balance involves the loosening of tire beads and the inflation of a tire. Training is necessary in tire changer operation and understanding the dangers involved during bead seating and tire inflation before attempting this stage of the Patch Weight Balance procedure. Read the operators manual supplied with the tire changer and consult a supervisor.

The patch weight balance steps are as follows:

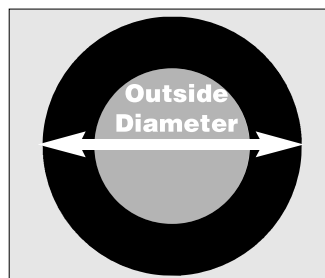

1. Measure the outside tire diameter, see figure 32, and enter this diameter manually on the patch menu screen, DIAMETER option **4**.

Figure 32 - Measure Outside Tire Diameter

2. Select PATCH option **3**. The balancer automatically sets itself for a STATIC balance.



Figure 33 - Patch Screen

3. Move the offset arm tip to the inside of rim to set tape-a-weight™ location. Wait for beep.

4. Spin the wheel.

5. Align the on-screen arrows. Next, mark the tire at 12 o'clock. Then remove the wheel assembly from the machine.

6. Disassemble the tire and rim. Place patch weight in the tire at location marked on the tire. Reassemble tire and rim matching the marks on the tire and rim.

7. Complete by balancing the wheel assembly following normal procedures.

Video Balancer

Additional Options

Be aware of the following options that appear on selected screens. Press the numbered key that corresponds with the key icon for each additional option described below.

- 5 OZ/g** - toggle between ounce or gram weight measurements. Note that this option appears on the weight placement screen (profile view) after the wheel has been spun.
- 6 Spoke** - To balance with adhesive weights located behind the spokes in the outer correction plane.

The spoke balance steps are as follows:

- 1.** Begin by balancing the wheel assembly following normal procedures for either the ALU-1 or ALU-2 mode.
- 2.** When the unbalance is displayed, attach the left side corrective weight.
- 3.** Next, select SPOKE option **6**.
- 4.** Rotate the wheel to position the right side yellow marker (ball) until it turns green. Select NEXT option **6**.
- 5.** Rotate tire toward you until the first spoke is at 12 o'clock or TDC. Hold location and press **1**.
- 6.** Rotate tire away from you (past unbalance point) until the next spoke is at 12 o'clock or TDC. Hold location and press **2**.
- 7.** Observe, by rotating the tire, that there are now two hidden weight locations located behind the two specified spokes (3D mode), See figure 34. Use the offset arm to attach the two right side corrective weights.



Figure 34 - Spoke Weight Placement Screen

- 6 Unspoke** - If you decide not to use the spoke option, press this option. Only one right side marker (ball) will display.
- 6 Printer** - (available in 3D view) prints a certificate with important balancing information. Note that this option appears on matching screen. See PRINTER on page 9 for further details.
- 6 L.T.** - For one spin only, press this to change the weight roundoff from 0.25 oz. to 0.5 oz. Note that this Light Truck option shows up after taking a dimension reading with the offset arm.

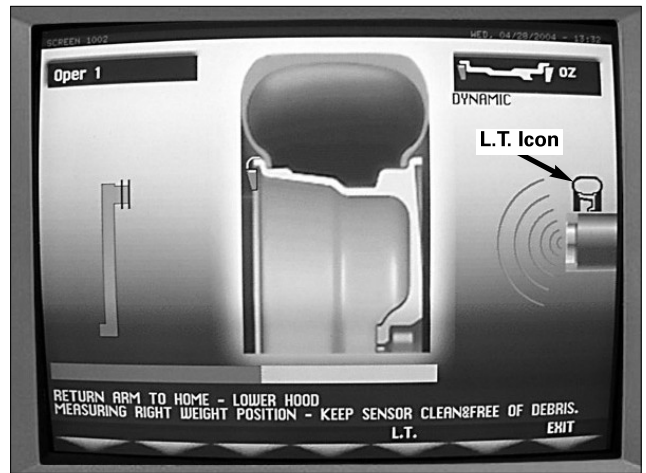

Figure 35 - The L.T. Icon Indicates Weight Roundoff Change

- 5 Econo Balance Mode** - Toggle the Econo Balance Mode ON or OFF. * Set to OFF.

EB (Econo Balance) is an alternate approach to balancing a tire and wheel assembly. The technology seeks first to eliminate the static imbalance in a wheel assembly then, based on several parameters, calculates the minimum amount of corrective weight needed to bring dynamic imbalance within acceptable limits.

Balancing wheel assemblies using EB mode often results in the application of less corrective weight. In addition to the potential productivity savings due to a reduction in the number of "re-spins" necessary to achieve an acceptable balance condition.

Video Balancer

Matching



A matching procedure may involve the loosening of tire beads and the inflation of a tire. Training is necessary in tire changer operation and understanding the dangers involved during bead seating and tire inflation before attempting this stage of a matching procedure. Read the operators manual supplied with the tire changer and consult a supervisor.

The operator can choose from two procedures to correct for a runout condition. Typically, if the static limit unbalance is exceeded, the operator will choose Optimization (Match Balance) to correct the situation. Or, if the radial runout limit is exceeded, the operator will choose to use the Runout (Runout Match) procedure to correct the situation.

Whenever a large unbalance or runout condition is detected, a runout procedure can be accessed manually by selecting the **MENU** button and then either the OPTIMIZATION (MATCH BALANCE) option **1** or the RUNOUT (RUNOUT MATCH) option **2**.

To view the Static-on-Screen™ value, press the **MENU** key, select the SPECIAL FUNCTIONS option **7**, and set the STATIC UNBALANCE DISPLAYED option **4** to ON. The Static-on-Screen™ reading, see page 11, will appear in the upper left-hand side of the screen.

Automatic Runout Detection

The wheel balancer software can be set to automatically detect a wheel assembly that exceeds the static limit unbalance or radial runout limit. A Runout Diagnostic screen will appear, see figure 36, that provides on-screen information for the operator.

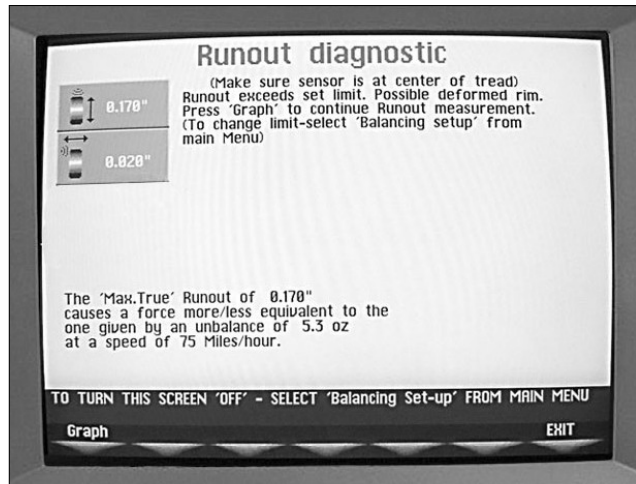

Figure 36 - Runout Diagnostic Screen

To set the wheel balancer to automatically detect runout, press the **MENU** button, select the BALANCING SET-UP option **6**, and set the RUNOUT DIAGNOSTIC option **5** to ON.

When the Runout Diagnostic option is ON, the radial runout sensor should also be set. Press the **MENU** button, select the GENERAL SET-UP option **5**, and set the RUNOUT UNLOADED ↕ option **7** to SONAR.

The Runout Diagnostic screen will always appear when the measured runout exceeds the MAX. TRUE RUNOUT LIMIT setting. To change this setting, press the **MENU** button, select the BALANCING SET-UP option **6**, and select the RUNOUT LIMITS option **7**. Then select the MAX. TRUE RUNOUT LIMIT option **1**; press and hold the button down to scroll to the desired amount.

Note: If the Runout Diagnostic screen appears and the runout is below the set limit, it is because the static unbalance exceeds 3.00 ounces. In this case, consider the OPTIMIZATION (MATCH BALANCE) procedure to correct the condition.

Also at the runout limits screen (RUNOUT LIMITS option **7**), select the RIM RUNOUT LIMIT option **2** to scroll to the desired rim tolerance amount and select the CORRECTION RUNOUT LIMIT option **3** to scroll to the desired tire/wheel tolerance amount.

Video Balancer

Optimization (Match Balance)

The Tire/Rim Weight Optimization procedure is used to determine the best mating of tire and rim that will result in the least amount of total unbalance of the assembly. It requires two spins and two rotations of the tire on the rim. Optimization may be needed when:

- The customer complains of ride problems.
- The balancer calls for total static weights in excess of 3 ounces (85 grams) on passenger car tires.

To set the wheel balancer to automatically detect an excessive static unbalance, press the **MENU** button, select the GENERAL SET-UP option **5**, and set the EXCESSIVE STATIC UNBALANCE option **5** to ON. A screen (see fig. 37A) will appear when the excessive static unbalance is detected.

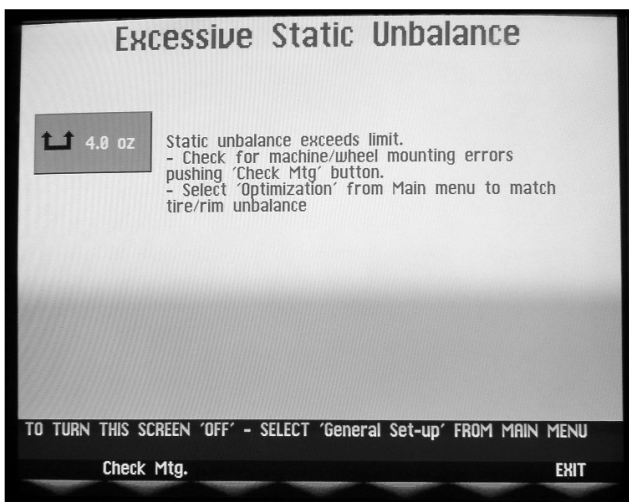

Figure 37A - Excessive Static Unbalance Screen

Note: A high unbalance may indicate the improper mounting of the assembly on the balancer, or a rim that is out of round or misformed, or a tire with a bubble or other problem. If the unbalance is excessive, it may be prudent to replace the rim, the tire, or both. If either is replaced, do not continue with optimization. Balance the new tire and rim and evaluate the readings.

To check for machine/wheel mounting errors, select CHECK MTG. **2** at the Excessive Static Unbalance screen and follow the on-screen instructions.

If you choose to use Optimization, then select the **MENU** key for the menu screen, and then select the OPTIMIZATION (MATCH BALANCE) option **1**. Follow the on-screen instructions for the TIRE/RIM WEIGHT OPTIMIZATION procedure as outlined in the following steps.

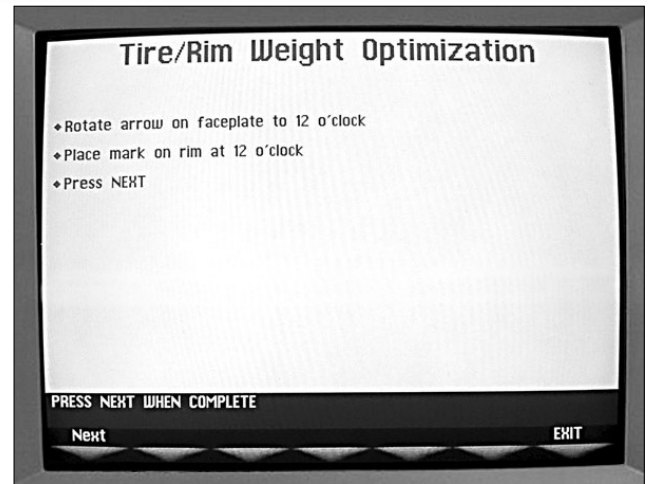

Figure 37B - Tire/Rim Weight Optimization Screen

Note: Use this procedure only after the wheel has spun and weights are displayed.

1. Rotate arrow on faceplate to 12 o'clock. Place a mark (backside of the wheel) on the rim at 12 o'clock. Press the NEXT option **1**.
2. Remove the wheel assembly from the balancer.
3. Using a tire changer, rotate the tire 180 degrees on the rim.
4. Replace wheel assembly on balancer and align the faceplate arrow with the mark on rim. Lower the hood and press the NEXT option **1**. The wheel spins.
5. Rotate the wheel until a red box appears at the yellow arrows. Put a second mark (frontside of wheel) on the rim at 12 o'clock.



6. Rotate the wheel until a red box appears at the green arrows. Put a third mark (frontside of wheel) on the tire at 12 o'clock. Press the NEXT option **1**.



Note: The rim unbalance and tire unbalance values are displayed on the screen.

7. Remove wheel assembly from balancer.
8. Using a tire changer, align the mark on the rim with mark on the tire.
9. Replace the wheel assembly on the balancer. Align the faceplate arrow with the previous mark (backside) on the rim to check improvement or just continue with step 10.
10. Press NEXT option **1** and balance the assembly.

Video Balancer

Runout (Runout Match)

Select the **MENU** button and then the RUNOUT (RUNOUT MATCHING) option **2** or, if the wheel balancer software is set to automatically detect runout, select GRAPH **1** at the Runout Diagnostic screen.

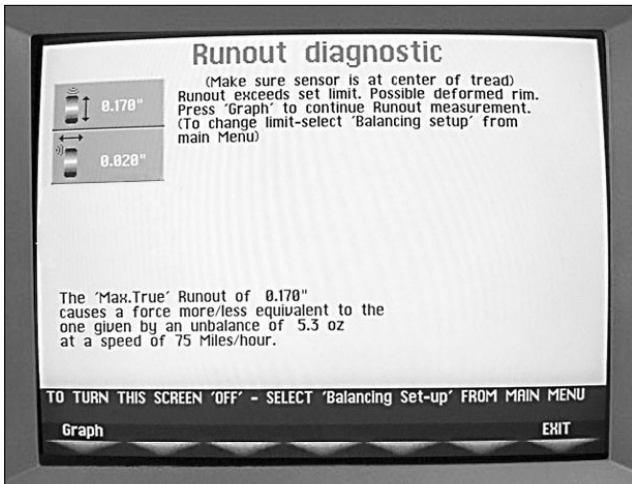

Figure 38 - Select Graph at the Runout Diagnostic Screen

Evaluate runout information at the "graph" screen, see figure 39. The red curve in the upper graph is the average radial runout of the assembly that is how much the runout of the assembly mimics running "off-center". The red curve in the lower graph is the average lateral runout of the assembly and a large number here indicates a bent rim, deformed sidewall, or both.

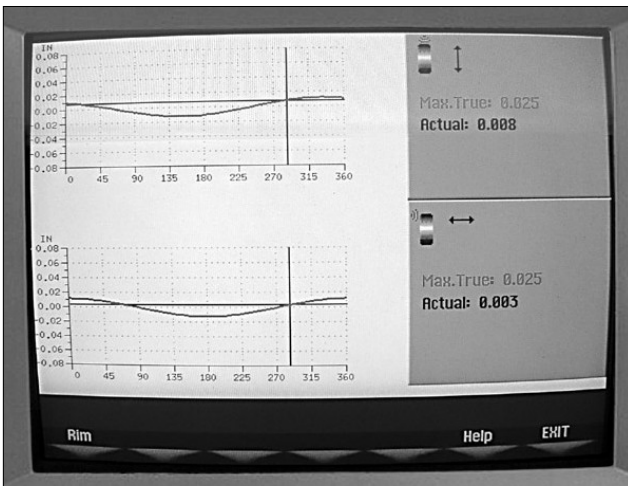

Figure 39 - Runout Measurement Screen

1. At the "graph" screen, select Rim to evaluate the rim versus the tire radial runout. Follow the on-screen instructions.

2. Touch the rim with the diameter arm.

Note: Place the offset arm, as shown on-screen, just under the inside of the barrel of the rim and hold in

place. **Do not place the offset arm at the clip-on weight location.**

3. Press **START** and turn the wheel slowly.

Note: Hold the offset arm in place one revolution until you reach 100%. Your progress is displayed on-screen.

The wheel balancer software calculates and displays a possible assembly runout reduction in inches based on the suggested tire on rim positioning. At this point, based on the possible reduction, choose to continue or exit the procedure. If the reduction amount does not exceed the CORRECTION RUNOUT LIMIT setting, the screen will display "Assembly Cannot Be Corrected by Matching"

4. 1. Mark tire and rim in the suggested position.

To mark the tire position, rotate the wheel in the direction of the black arrows until the red "chalk" icon appears on the tire. Step on the positioning pedal, then mark the tire on the outside at top-dead-center.

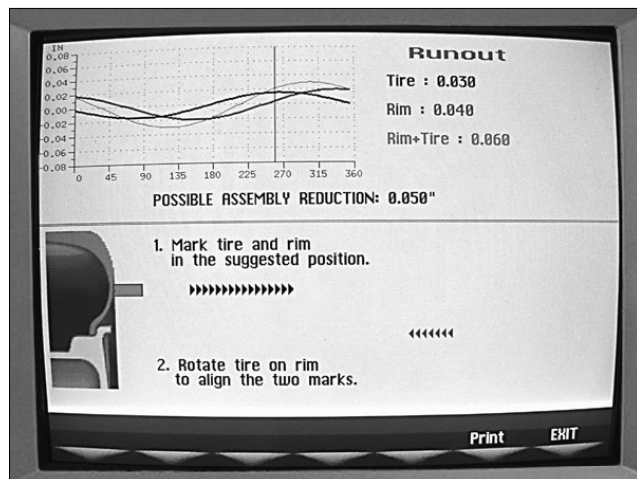

Figure 40 - "Chalk" Icon to Indicate TDC Tire Position

To mark the rim position, rotate the wheel in the direction of the blue arrows until the red "chalk" icon appears on the rim. Step on the positioning pedal, then mark the rim on the outside at top-dead-center.

5. 2. Rotate tire on rim to align the two marks.

Remove the wheel from the balancer. Using the tire changer, break down the assembly and position the tire and rim so that the marks line up. The tire is now optimized.

Complete by balancing the wheel assembly following normal procedures.

Video Balancer

Manually Setting Wheel Dimensions (DIM)

Definition of dimensions (DIM):

A = Offset The distance measured from the balancer ("0" on the offset arm) to the inner plane of the rim (inner weight location).

W = Width The width of the wheel at the rim flanges, measured with the calipers as shown in figure 42.

Note: Only use calipers provided by the wheel balancer manufacturer because others may not be the same.

D = Diameter The diameter of the wheel as indicated on the tire.



Figure 41 - Manual Measurements Screen

When necessary, the wheel dimensions can be inserted or edited in manual mode. At the initial screen or during calibrations follow these instructions on-screen when setting DIM option **3**.

Manually Setting "A" DIM

1. Press SELECT option **4** to highlight (in red) the rim offset (A) DIM.

2. Position offset arm at clip-on weight location on wheel and read the number, on the slide out offset arm, at the cabinet (this is the correct offset DIM).

3. Using + **5** or - **6**, manually set the offset DIM on-screen (highlighted red) to match the offset number of the mounted tire.

Manually Setting "W" DIM

1. Press SELECT option **4** to highlight (in red) the rim width (W) DIM.

2. Use the plastic calipers provided with the wheel balancer to measure the wheel width.

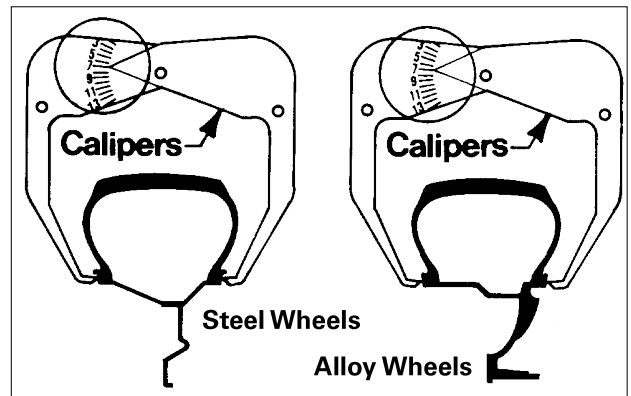

Figure 42 - Caliper Location Diagrams

3. Using + **5** or - **6**, manually set the rim width DIM on-screen (highlighted red) to match the measured caliper width of the mounted rim.

Manually Setting "D" DIM

1. Press SELECT option **4** to highlight (in red) the rim diameter (D) DIM.

2. Inspect mounted tire sidewall to determine the exact diameter that is printed on the tire.

3. Using + **5** or - **6**, manually set the tire diameter DIM on-screen (highlighted red) to match the tire sidewall size.

Video Balancer

Mounting Wheel on Spindle Shaft



Avoid back injury, seek assistance when lifting heavy tire/rim assemblies onto the balancer shaft.

Select the most appropriate mounting method for the wheel you are balancing. Using the proper method ensures secure mounting and safe balancer operation, and prevents damage to the wheel.

On most wheels, the inner side of the wheel hub usually has the most uniform surface for wheel balancing. Always center the wheel by the most uniform shaped side of the hub to achieve the most accurate balance.

Regardless of mounting type, always make sure that the wheel is forced firmly against the shaft faceplate and that the hub nut engages the threaded shaft for at least four complete turns. To assist in centering the wheel properly, rotate the wheel and the shaft while tightening the hub nut.

Standard Back Cone Mounting

Most original equipment and steel wheels can be mounted properly using this method. The wheel is centered on a cone from the inner side of the hub.

- 1.** Select the cone that best fits the center hole in the wheel. Slide the cone onto the shaft with the large end towards the faceplate.
- 2.** Lift the wheel onto the shaft and center it on the cone.
- 3.** Attach the pressure cup to the hub nut and install the assembly onto the shaft. Tighten securely.

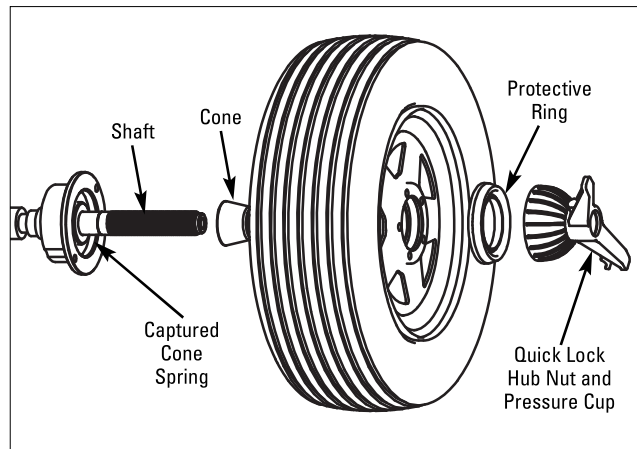

Figure 43 - Back Cone Mounting

Video Balancer

Standard Front Cone Mounting

A wheel should be centered by the outer side of the hub only when the inner surface will not provide an accurate surface to center on.

- 1.** Select the cone that best fits the center hole in the wheel.
- 2.** Lift the wheel onto the shaft and slide it back against the shaft faceplate.
- 3.** Slide the cone onto the shaft and into the center of the wheel. You will need to lift the tire to seat the cone in the center hole.
- 4.** Install the hub nut (without pressure cup) onto the shaft. Tighten it securely against the cone.

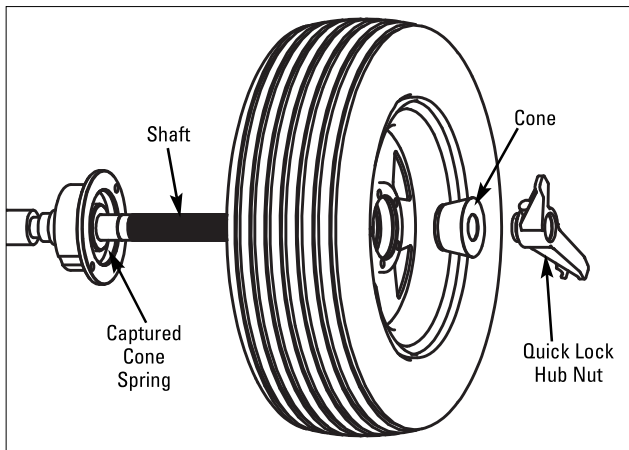

Figure 44 - Front Cone Mounting

Alternate Mounting

If the wheel has a protruding outer hub which will not permit the use of the pressure cup, or the cup will not permit the hub nut to engage at least four turns of the shaft, this alternate method should be used.

- 1.** Select the cone that best fits the center hole in the wheel. Slide the cone onto the shaft with the large end towards the faceplate.
- 2.** Lift the wheel onto the shaft and center it on the cone.
- 3.** Use the small nylon spacer (no-mar ring) or a centering cone to press against the outer wheel hub.
- 4.** Install the hub nut (without the pressure cup) onto the shaft. Tighten securely.

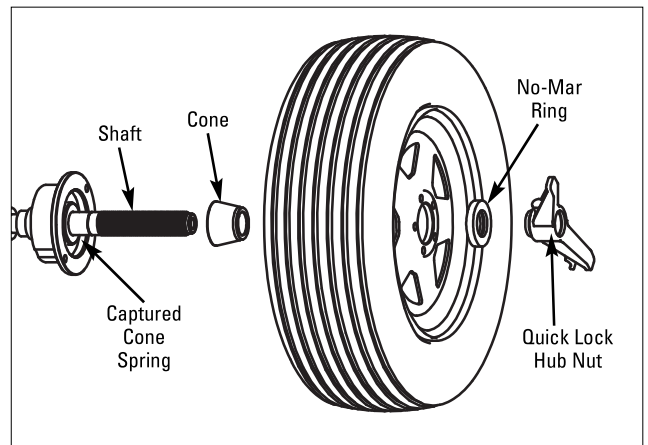

Figure 45 - Alternate Mounting

Video Balancer

Machine Self-calibration and Service Adjustments

The wheel balancer provides step by step on-screen instructions for MACHINE SELF-CALIBRATION and SPECIAL ADJUSTMENTS. Choose MACHINE SELF-CALIBRATION when on numerous wheels a one-spin balance is not achievable. Choose SPECIAL ADJUSTMENTS when components are added or replaced that may effect machine dimension measurements.

Machine Self-calibration

Important: Prior to performing the machine self-calibration, refer to the functional check for calibration on the back cover.

To access the Machine Self-calibration menu, press the **MENU** key, then select SPECIAL FUNCTIONS option **7** and choose MACHINE SELF-CALIBRATION selection **6**. Follow these instructions on-screen:

1. DO NOT CALIBRATE UNTIL YOU HAVE CHECKED THE FOLLOWING:

- Check Stub Shaft Tightness
- Check for Proper Mounting of Tire/Wheel and for Speed-Nut Slippage
- Manually Check Wheel Dimensions: Check That It Matches The Wheel Dimension Icon Within Approx. 1/4-inch.
- Perform Functional Check Per Procedure
- Check for Proper Phase at Machine Self-Test Screen

To check for these causes press EXIT or press NEXT to continue.

2. Mount a 14", 15", or 16" steel wheel with tire. A balanced tire/wheel works best. Press NEXT option **1** to continue.

3. At this DIM screen manually set the dimensions carefully before proceeding. See MANUALLY SETTING WHEEL DIMENSIONS (DIM) on page 23 for further instructions. Press NEXT option **1** to continue.

Important: Dimensions must match the "calibration wheel". A dimension cannot be zero.

4. Lower the hood; then press the **START** key.

5. After spin, raise the hood and add test weight to outside flange at any location: 4.00 oz. (Be sure there are no weights at same location on the inside rim flange.)

6. Lower the hood; then press the **START** key.

7. After spin, raise the hood and remove the test weight on the outside flange and place it directly across on the inside flange.



Figure 46A - Test Weight Inside Flange Position

8. Lower the hood; then press the **START** key.

9. Raise the hood, rotate the wheel until the test weight is at 12 o'clock or TDC and hold at this position.

Note: Step 8 is important, do not skip it.

10. While holding at the TDC position, press NEXT option **1**.



Figure 46B - Test Weight Inside Flange Position

11. Calibration Accepted, press NEXT to EXIT Machine Self-calibration.

Video Balancer

Service Adjustments

Press the **MENU** key and select SERVICE ADJUSTMENTS option **4** for the following menu selections.

Important: These service adjustments are password protected. Contact your factory trained COATS® Service Technician before attempting any upgrade or repair that may affect the machine dimension measurement system.

★ Shown with Recommended Settings

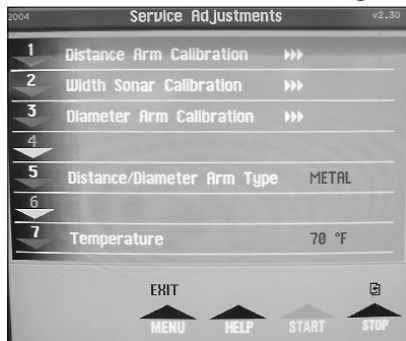

Figure 47 - Service Adjustments Screen

- 1 Distance Arm Calibration** - Calibrates the distance part of the offset arm.
- 2 Width Sonar Calibration** - Calibrates the width using a sensor.
- 3 Diameter Arm Calibration** - Calibrates the diameter part of the offset arm.
- 5 Distance/Diameter Arm Type** - Toggle to METAL or PLASTIC. Set to match the style/type of arm installed on the balancer.
- 7 Temperature** - Ambient temperature setting for sonar. ★ Recommended setting is 70° F.

Distance Arm Calibration

Note: Calibrate the offset arm first, since it is very important that the wheel dimensions are correct.

Follow these instructions on-screen when calibrating the DISTANCE ARM CALIBRATION option **1**:

- 1.** Move offset arm to position 0 on gauge, hold and press NEXT option **1**.
- 2.** Move offset arm to position 6 (not 0.6-inch) on gauge, hold and press NEXT option **1**.

Note: Position the gauge as shown in figure 48.



Figure 48 - Distance Arm Calibration

- 3.** Return offset arm to home position.
- 4.** Calibration Accepted.
- 5.** Press NEXT option **1** to return to Service Adjustments.

Width Sonar Calibration (If equipped)

Follow these instructions on-screen when calibrating the WIDTH SONAR CALIBRATION option **2**:

- 1.** Move the arm gauge to front of faceplate (outer edge of large diameter). Hold at position and press NEXT option **1**.

Note: It is highly important to position the gauge correctly as shown in figure 49A (plastic arm) or figure 49B (metal arm).



Figure 49A - Plastic Offset Arm Gauge to Faceplate

Video Balancer

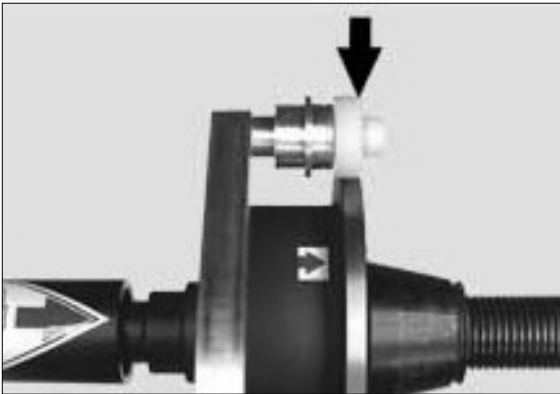

Figure 49B - Metal Offset Arm Gauge to Faceplate

2. Return offset arm to home position.
3. Pull out and position the Calibration Target Bracket to front of faceplate.
4. Leave in position and close the hood.

Note: The Calibration Target Bracket, shown in calibration position in figure 50, is used to allow the width sonar to measure the distance to the balancer faceplate during calibration.

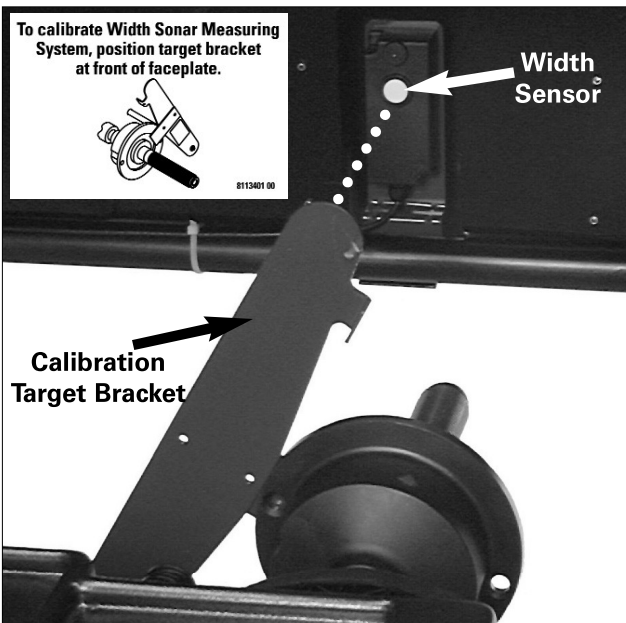

Figure 50 - Target Bracket Positioned for Calibration

5. Screen indicates "Reading Value".
6. Raise the hood and return the Width Sonar Calibration Bracket to the stored position.
7. Calibration accepted.
8. Return sensor target bracket to stored position then press NEXT option **1** to return to Service Adjustments.

Note: The sonar calibration target bracket is stored flush with the side of cabinet at all other times, see figure 51.

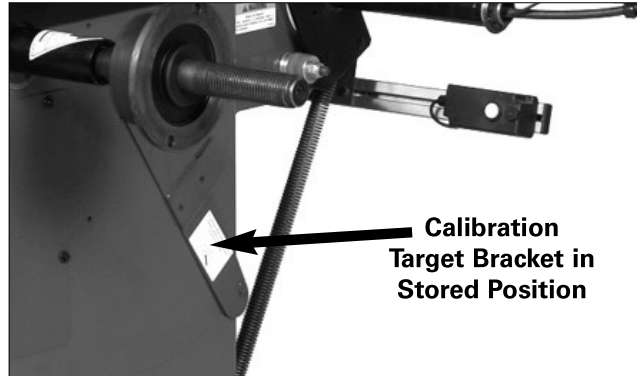

Figure 51- Sonar Target Bracket in Stored Position

Diameter Arm Calibration (Plastic)

Note: Be sure the correct Distance/Diameter Arm Type is set (See Service Adjustments page 27).

Follow these instructions on-screen when calibrating the DIAMETER ARM CALIBRATION option **3** (plastic arm type):

1. Mount a 14", 15", or 16" steel wheel with tire.
 2. Using the + or -, set the diameter to the same diameter as rim.
 3. Press NEXT option **1**.
- Note:** The diameter will display on the screen.
4. Position offset arm at clip-on weight location on wheel.



Figure 52 - Diameter Arm (Plastic) Calibration

5. Hold at location and press NEXT option **1**.
6. Screen indicates "Reading Value".
7. Return offset arm to home position.
8. Calibration Accepted.
9. Press NEXT option **1** to return to Service Adjustments or option **7** to EXIT.

Video Balancer

Diameter Arm Calibration (Metal)

Note: Be sure the correct Distance/Diameter Arm Type is set (See Service Adjustments page 27).

Follow these instructions on-screen when calibrating the DIAMETER ARM CALIBRATION option **3** (metal arm type):

1. Position the arm roller at upper position on the faceplate hub with the tip on back of flange.

2. Hold at position and press NEXT option **1**.

Note: The position will display on the screen.

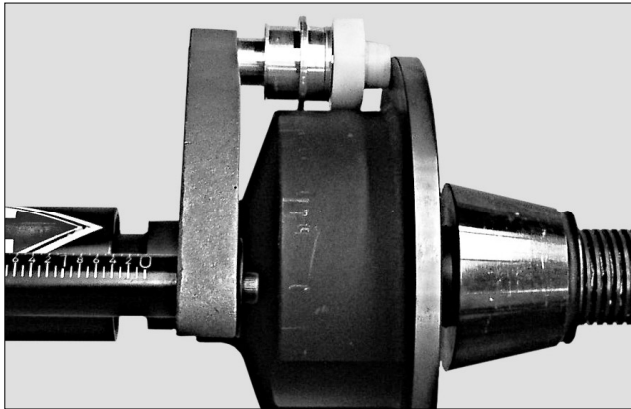

Figure 53 - Hold Roller Tip At Upper Position And Press NEXT

3. Rotate and position the arm roller at lower position on the faceplate hub with the tip on back of flange.

4. Hold at position and press NEXT option **1**.

Note: The position will display on the screen.

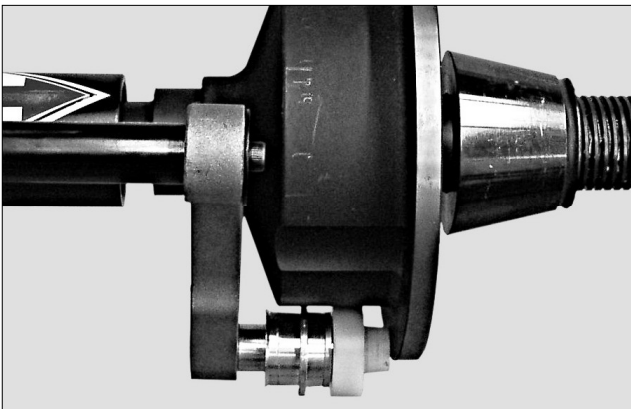

Figure 54 - Hold Roller Tip At Lower Position And Press NEXT

5. Return offset arm to home position.

6. Calibration Accepted.

7. Press NEXT option **1** to return to Service Adjustments or option **7** to EXIT.

Diagnostic Procedures

After Balance Vibration Problems

If vibration is still present after balancing the wheels and driving the vehicle on smooth pavement, remove the wheels and recheck the balance. If a wheel is out of balance the cause maybe:

- Wheel was not mounted/centered correctly on the balancer.
- A weight has come off the wheel (possibly the wrong clip style). Remove the other weights from the wheel and rebalance.
- Foreign material inside the tire. Remove the tire from the wheel, remove the foreign material, and remount. Remove wheel weights and rebalance the wheel.
- Stones or other foreign objects caught in the tire tread or rim. Remove the objects. Check and rebalance if needed.

If the balancer still indicates the wheels are balanced to within 0.05 ounces on both inner and outer displays, the problem is not in the balance of the wheels. Check the following possible sources of vibration:

- Tire pressure. Bring all tires up to the recommended PSI.
- Radial or lateral runout in the tire or wheel. Replace the damaged part.
- Unbalance in wheel covers or trim rings. Remove the wheel covers or trim rings and test drive. If the vibration is gone, remove the shaft and use an appropriate adapter to mount the wheel to the balancer. Balance the wheel with the wheel cover or trim ring attached to the wheel.
- Incorrectly mounted wheel. Remount correctly.
- Damaged wheel bolt holes. Replace wheel.
- Worn universal joints. Replace as required.
- Drive shaft unbalance or damaged. Balance, repair, or replace.
- Unbalance in brake rotor(s) or drum(s).
- Suspension out of alignment. Align the vehicle and replace any damaged or worn parts.

Video Balancer

Troubleshooting

A COATS® Service Technician may ask for information to help diagnose service concerns. Conveying this information to your service technician prior to servicing can help to expedite service to your equipment. Although much of the diagnostic information aids your COATS® Service Technician, several remedies for balancer misfunctions are available to the operator.

Note: Always EXIT error message and repeat function to see if error is eliminated.

The following lists error screens (numbered) that may appear indicating a problem with the balancer.

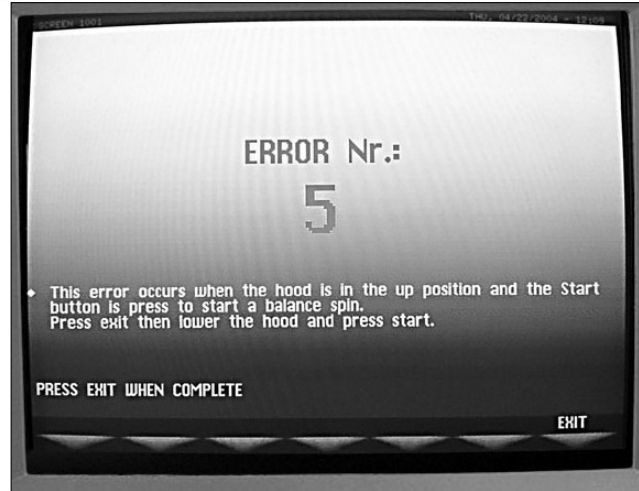

Figure 55 - Example Error Screen

Error	Symptom	Check
No Video	The balancer does not turn on.	<ol style="list-style-type: none"> 1. Check for proper connection to the power supply. 2. Check and replace fuses on the power PCB if necessary. 3. Check the monitor function - press monitor menu button. (see trouble shooting tips) 4. Check control transformer output. 5. Check FS1 & FS2 fuses on power PCB. 6. Check power cable to main PCB & output at power PCB. 7. Replace power PCB. 8. Replace the main PCB.
Err. 1	Rotation signal missing. Wheel spins too fast & no brake. Balancer does not start. Motor turns nut no rotation.	<ol style="list-style-type: none"> 1. Check the belt tightness. 2. Encoder disconnected, bad or damaged wiring, failed optical unit - no reset signal. 3. Check hood switch operation. 4. Replace the encoder unit. 5. Motor disconnected or bad wiring - check for motor voltage at power PCB - check circuit breaker - check machine power. 6. If motor hums - remove belt and check for motor rotation at pulley - if rotation, replace capacitor. 7. Check for faulty power PCB or main PCB.
Err. 2	Too low speed when taking the measurement. During turns to measure the unbalance value, the wheel speed has gone below 42 r.p.m.	<ol style="list-style-type: none"> 1. Very light / small wheel mounted on balancer - not enough inertia to keep wheel rotating. 2. Check belt tightening. 3. Check the operation and adjustment of the encoder and in particular, the reset signal. (in MACHINE SELF-TEST, Pos counts from 0 to 255 and then 0 again). UP = cw, DOWN = ccw. 4. Replace the main PCB.

Video Balancer

Error	Symptom	Check
Err. 3	Calculation Error. Incorrect Machine Self-Calibration.	<ol style="list-style-type: none"> 1. Check the wheel dimensions setting. 2. Check the piezo pick-ups connections - electrical & mechanical. (in MACHINE SELF-TEST, push on spindle shaft and verify that both piezo outputs change. 3. Execute the 4-ounce weight (machine self-calibration). 4. Mount a wheel having a known unbalance (lower than 4.00 ounces or 100 grams) and check the balancer reading. 5. Replace the PC board.
Err. 4	Counterclockwise rotation. After pushing START the wheel turns in the opposite direction.	<ol style="list-style-type: none"> 1. In MACHINE SELF-TEST - check the operation of UP/DOWN - RESET signals of the encoder. 2. Check the connection of the motor for rotation.
Err. 5	Wheel guard hood open or the START button has been pushed without closing the wheel guard hood.	<ol style="list-style-type: none"> 1. Reset the error by pushing button 7 = EXIT. 2. Close the wheel guard hood and press START button. 3. Check operation of the wheel guard micro-switch. 4. Press the START button.
Err. 6	Ram Error or defect.	<ol style="list-style-type: none"> 1. Reset NOVRAM & check operation or Replace PCB.
Err. 7 / Err. 8	Reading error of NOVRAM parameters.	<ol style="list-style-type: none"> 1. Repeat the entire balancer calibration. 2. Switch the balancer OFF. 3. Wait a minimum time of 1 minute (approx). 4. Switch the balancer ON and check the proper operation. 5. Replace the PCB board.
Err. 9	Access error in NOVRAM parameters writing.	<ol style="list-style-type: none"> 1. Replace the PCB board.
Err. 11	High speed error. During rotation to measure the unbalance value, the wheel speed has gone over 270 r.p.m.	<ol style="list-style-type: none"> 1. Check for possible damage or dirt on the encoder disc - clean dirt with a soft cloth - blow air across the optical units. 2. Check the operation and adjustment of the encoder and in particular, of the reset signal. (in MACHINE SELF-TEST, Pos counts from 0 to 255 and then 0 again). UP = cw. DOWN = ccw. 3. Replace the main PCB.
Err. 12	Error in the unbalance measuring cycle.	<ol style="list-style-type: none"> 1. Press EXIT and respin. Check PHASE in MACHINE SELF-TEST, if 180 deg diff., recalibrate & check piezos.. 2. Check encoder adjustment and operation. (clearance .020" to .035") 3. Check motor operation. 4. Check belt tightness. 5. Check hub nut tightness. 6. Replace the main PCB.

Video Balancer

Error	Symptom	Check
Err.13 Err.14 Err.17 Err.18	Error in the unbalance measurement.	<ol style="list-style-type: none"> 1. Press EXIT and respin. Check PHASE, VCO, VCI in MACHINE SELF-TEST. 2. Check the piezo pick-ups connection. (electrical & mechanical) 3. Check the balancer spindle connections. 4. Mount a wheel having a known unbalance (lower than 3.5oz or 100 grams) and check the balancer readings. 5. Replace the PC board.
Err.15 / Err.16 /	Over ranging - too much unbalance	<ol style="list-style-type: none"> A.) Follow screen instructions for "heavy side" down balancing to bring wheel unbalance into range and then balance normally. B.) Follow instructions 1 thru 5 above.
Err.19 Err.20	Wheel stopped before it was positioned or before taking runout reading.	<ol style="list-style-type: none"> 1. Wheel too light - not enough inertia. Use heavier wheel. 2. Check positioning of sonar unit behind wheel.
Err. 30	Clock error	<ol style="list-style-type: none"> 1. Replace the PC board
Err.40, 41, 42, 43	Error in the creating of the runout graph.	<ol style="list-style-type: none"> 1. Execute a new runout measurement.
Err.45, 46, 47, 48	Error in the reading of the values which are used to create the runout graph.	<ol style="list-style-type: none"> 1. Execute a new runout measurement.
Err.50, 51, 52, 53	Error in the writing procedure of the cursor for the current value of the runout graph.	<ol style="list-style-type: none"> 1. Execute a new runout measurement.
Err.54	Error in the Sonar reading. Sonar did not read any value.	<ol style="list-style-type: none"> 1. Before taking the measurement, make sure that the RADIAL RUNOUT SONAR is properly positioned. 2. Check the RADIAL RUNOUT SONAR connection. Unplug and replug at pwer PCB. 3. Check the power supplies on the power board. 4. Replace the RADIAL RUNOUT SONAR. 5. Check that the wheel doesn't stop before making at least 4 to 5 complete turns after the first breaking impulse. 6. Check belt tightening. 7. Replace the PC board

Video Balancer

Error	Symptom	Check
Err.55	Error in the Sonar reading. The values taken by the Sonar are insufficient for a correct runout measurement.	<ol style="list-style-type: none"> 1. Before taking the measurement, make sure that the RADIAL RUNOUT SONAR is properly positioned. 2. Check that the wheel doesn't stop before making at least 4 to 5 complete turns after the first braking impulse. 3. Check belt tightening. 4. Fit a medium-sized wheel (14" x 5-3/4") and execute an eccentricity measurement. If error 55 doesn't take place anymore, it means that the inertia of the wheel that gave the problem is the cause of the wheel stopping before the acquisition of the minimum number of values necessary for a reliable runout measurement.
Err.56	Error in Lateral Sonar reading. Sonar did not read any value.	<ol style="list-style-type: none"> 1. Before taking the measurement, make sure that the LATERAL RUNOUT SONAR is properly positioned. 2. Check the LATERAL RUNOUT SONAR connection. Unplug and replug at power PCB. 3. Check the power supplies on the power board. 4. Replace the Lateral Runout Sonar. 5. Check that the wheel doesn't stop before making at least 3 complete turns after the first braking pulse. 6. Check the belt tightening. 7. Replace the PC board.
Err.57	Error in the Lateral Sonar reading. The values taken by the Sonar are insufficient for a correct Lateral Runout measurement.	<ol style="list-style-type: none"> 1. Before taking the measurement, make sure that the LATERAL RUNOUT SONAR is properly positioned. 2. Check that the wheel doesn't stop before making at least 3 complete turns after the first braking pulse. 3. Check the belt tightening. 4. Fit a medium-sized wheel (14" x 5-3/4") and execute a lateral runout measurement. If error 57 doesn't take place anymore, it means that the inertia of the wheel that gave the problem is the cause of the wheel stopping before the acquisition of the minimum number of values necessary for a reliable runout measurement.
Err.58	Error in Radial and Lateral Sonar reading. No value was read by the Radial and Lateral Sonars.	<ol style="list-style-type: none"> 1. Check actions in Error 54. 2. Check actions in Error 56..
Err.59	Error in the Radial and Lateral Sonar reading. The values taken by the Radial and Lateral Sonars are insufficient for a correct Runout measurement.	<ol style="list-style-type: none"> 1. Check actions in Error 55. 2. Check actions in Error 57..
Err.65	Printer Not Connected.	<ol style="list-style-type: none"> 1. Check serial connector at computer PCB. 2. Check serial connections inside cabinet at wire tray.

Video Balancer

Machine Self-Test "Green Screen"

In the event of faulty wheel balancer operation, notify a COATS® Service Technician of all the machine self test readings. To view the self test screen, press the **MENU** key, select Special Functions option **7**, and select Machine Self-Test option **3**.

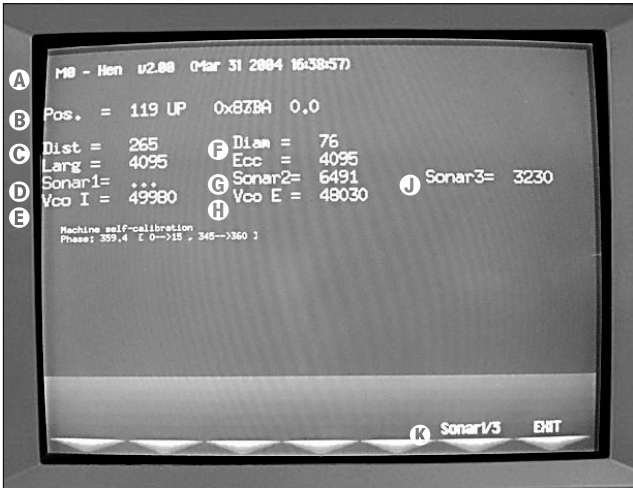

Figure 56 - Machine Self-Test Screen

A - This line provides software version and other technical information.

B (Pos.) - An encoder check. The word UP should appear when rotated clockwise and DOWN when rotated in the opposite direction.

C (Dist) - Check for correct operation of the distance arm gauge; the number increases when the gauge is pulled out.

D (Sonar 1) - Check of the hood width sensor (option): the number decreases when a surface is brought closer to the sensor device.

E (Vco I) - Piezo Output.

F (Diam) - Check for correct operation of the diameter gauge; the number increases when the offset arm is rotated outward.

G (Sonar 2) - Check of the radial runout sensor (option): the number decreases when a surface is brought closer to the sensor device.

H (Vco E) - Piezo Output.

J (Sonar 3) - Check of the lateral runout sensor (option): the number decreases when a surface is brought closer to the sensor device.

K - Toggle the Sonar 1/3 screen option **6**, to view either Sonar 1 or Sonar 3 diagnostic information.

Video Balancer

Maintenance Instructions

The balancer requires only minor maintenance to keep the unit operating properly.

- 1.** Keep the display clean and clear. Use a vaporizing cleaner only. Do not use cleaners or solvents which leave oily or filmy residues behind.
- 2.** Keep the adapters, cones, faceplate, threaded shaft, pressure cup, and hub nut clean. Grease and dirt buildup will cause inaccurate balancing and premature wear. Clean these items at least once a day with a vaporizing solvent.
- 3.** Clean the weight tray, accessory posts, pegs, and storage shelves with a vaporizing solvent. Weights stored in a dirty tray may pick up grease and dirt which may keep them from securely attaching to the wheel.



Do not hose down with water or bucket wash the balancer. Extensive damage to the balancer will result. Sensitive electronic components, wiring harnesses, and other devices housed in the balancer are not intended to be exposed to water.



Exposing the balancer to water, either by hose or bucket, or by exposure to rain or snow, may cause risk of shock or electrocution to operator or bystanders. Place, store, and operate the balancer only in a dry, sheltered location.

- 4.** Clean the sensor unit(s) using only a soft, water-dampened cloth (not wet). Do not use solvents as they may damage the white sensor area.
- 5.** Keep the area around the balancer clear. Remove any tools or other items that are leaning against the balancer. Keep the area under the balancer clear. Remove any items that may cause the balancer to not sit level. Be particularly cautious of new or used wheel weights on the floor, as they may cause personal injury due to falls.
- 6.** Use only COATS® accessories. Accessories from other manufacturers may not fit or function properly, and may damage the balancer.

Monitor Screen Adjustment

The monitor control panel buttons are located on the monitor. To access the buttons, lift the monitor front up.



Figure 57 - Monitor Control Panel Buttons

Video Balancer

Installation Instructions

Receiving

The shipment should be thoroughly inspected as soon as it is received. The signed bill of lading is acknowledgement, for the carrier, of receipt in good condition of the shipment covered by our invoice.

If any of the goods called for on this bill of lading are shorted or damaged, do not accept them until the carrier makes a notation of the shorted or damaged goods on the freight bill. Do this for your own protection.

NOTIFY THE CARRIER AT ONCE if any hidden loss or damage is discovered after receipt and request him to make an inspection. If the carrier will not do so, prepare an affidavit to the effect that you have so notified the carrier (on a certain date) and that he has failed to comply with your request.

IT IS DIFFICULT TO COLLECT FOR LOSS OR DAMAGE AFTER YOU HAVE GIVEN THE CARRIER A CLEAR RECEIPT.

File your claim with the carrier promptly. Support your claim with copies of the bill of lading, freight bill, invoice, and photographs, if possible.

Although COATS responsibility ceases upon delivery of the shipment to the carrier, we will gladly assist in tracing lost shipments. Our willingness to assist in every possible manner does not make COATS responsible for collection of claims, or replacement of lost or damaged materials.

Electrical Requirements

The wheel balancer requires a 115 VAC, 60HZ, single-phase power. Plugs into standard 15 amp outlet.

Always have a qualified electrician install 3-prong receptacles in accordance with state and local codes.

Some special order wheel balancers may require different voltages. See serial tag for the appropriate power requirements of your machine.

Setup



Do not use the monitor, monitor base, accessory storage, faceplate, hood or shaft to lift the balancer.



Do not attempt to install and setup the unit yourself. Contact COATS® as noted below.

A factory trained COATS® Service Technician must perform the install, setup, and initial test procedures on your wheel balancer. Do not attempt to install and setup the unit yourself. Accurate and reliable operation of your unit depends on proper installation. Please contact COATS® directly at 1-800-688-9240 for the Certified Service Partner nearest you.

Air Supply Connection

The wheel balancer requires a minimum 2 CFM air source at 60 PSI. This system is only intended for adjusting the inflation of tires.

Connect to Power

Your factory trained COATS® Service Technician should do the final check to verify the power installation before connecting the balancer to a power supply. Failure due to improper power connection may void the warranty.

Video Balancer

Floor and Space Requirements

The balancer must be located on a flat floor of solid construction, preferably concrete. The balancer must sit solidly on its three feet. If the balancer is not level, does not sit solidly on its three feet, or is placed on an unstable floor, the balancer will not function properly and may produce inaccurate balance readings.

Do not operate the balancer while it is on the pallet.

Select a location for the balancer that provides a level, solid floor, and adequate clearance around and above the balancer. Make sure the location selected has enough room above and behind the unit so the hood can be raised completely. The location must also provide working room for mounting and removing wheels. Make sure the area has adequate lighting.

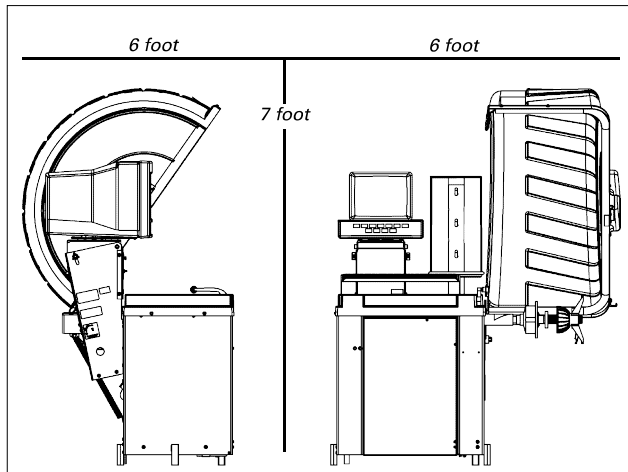

Figure 58 - Footprint Diagram

Video Balancer

Specifications

Cycle Time

8 seconds (average 50 pound tire)

Maximum Outside Tire Diameter

44 inches

Maximum Tire/Wheel Weight

160 pounds (72 kg)

Wheel Diameter Range (with Offset Arm or Manual)

10 - 24 inches

Wheel Width Range

2 - 20 inches

Balancing Display Increments

0.25 or 0.01 ounces

Resolution (Non-Round Off Mode)

0.01 ounce, position 0.70 degrees

Resolution (Round Off Mode)

0.25 ounce, position 0.70 degrees

Temperature at Balancer Location

50 degrees - 105 degrees Fahrenheit

Mounting Shaft Diameter

40 MM standard

Electrical (115 V, 1 Ph, 60 Hz)

standard 15 AMP 3-prong outlet

Shipping Weight

680 pounds (308 Kg)

Net Weight with Standard Accessories

465 pounds (211 Kg)

Balancer RPM

185 - 205 RPM

Features

- 15 inch VGA CRT Monitor w/Tilt and Swivel Adjustments
- Automatic Data Entry for Offset, Width, and Diameter - Manual Entry Backup on all Parameters
- Interactive Screens for all Modes and Functions with Superior Graphic Displays
- Static-on-Screen™
- Four Fixed Function Keys, Seven Program Keys for user Friendly Operation
- Many Balancing Modes
 - Dynamic (Standard): Clip-on Weights
 - 4 Alloy: User Defined
 - 2 PAX: User Defined
 - 4 Static
 - Patch (Tire Weight): Static Only
 - Behind the Spoke Weight Placement (All Modes with Inside Wheel Weights)
- Auto Start When Hood is Lowered
- Vertical Wheel Mounting System
- Single Spin Balancing - Dynamic and Static
- Easy-To-Read Position Indicators
- Interactive Tape-A-Weight™ Placement with Offset Arm
- Cone Spring Permanently Retained in Faceplate
- Hood Safety Interlock System
- Extended Mounting Faceplate for Deeper Wheels
- Removable Center Shaft for Closed Center Wheels
- Match Mount (Optimization) Function with Weight Optimization Program
- Can be Programmed for Four Different Users
- User Friendly Weight and Position Calibration
- Easy Calibration of Automatic Data Entry Devices
- No Bolt-down Installation
- Solid State Motor Control
- Econo Balance Mode
- UL/CSA Listing Pending

Video Balancer

Required Accessories

- 3 Piece Graduated Cone Assortment (Small Cone 8112098, Medium Cone 8112099, Large Cone 8112100), 40 MM ID, Hardened and Ground both ID and OD
- Large Adapter (Truck Cone 8112101)
- Cone Spring (Permanently Retained in Faceplate)
- Quick Lock Hub Nut and Pressure Cup (80180096)
- No-Mar Ring (80180097)
- Rim Width Calipers (8309011)
- Wheel Weight Pliers (8111515)



Optional Accessories



Video Balancer

Notes

Video Balancer

Glossary of Terms

BDC - an acronym for bottom-dead-center, also referred to as the 6 o'clock position.

Dynamic Balance - balancing a wheel using two planes for correction. Dynamic balance means the wheel is in balance when in motion about its rotational axis. Also, a wheel is statically balanced when dynamically balanced. However, a wheel that is statically balanced is not necessarily dynamically balanced.

Hub Centric - refers to mounting and means the wheel is centered to the vehicle by the center hole on the wheel and the pilot on the vehicle axle. The maximum clearance between the wheel's center hole or bore and the axle pilot is between 0.0015 and 0.006 normally.

Inner Plane - the closest corrective weight location from the balancer.

Lug Centric - refers to mounting and means the wheel is centered by the studs and nuts mounted on the axle of the vehicle. This is the least desirable way to mount a wheel; very difficult to maintain the wheel centering on the vehicle axle.

Offset Arm - pivoting arm that measures A & D wheel dimensions.

A - distance measured from the balancer ("0" on the offset arm) to the inner plane of the rim (inner weight location).

D - diameter of the wheel at the weight location, which is not always the same as the bead seat diameter that determines tire diameter.

W - width between the inner and outer planes.

Outer Plane - farthest corrective weight location from the balancer.

Static Balance - balancing a wheel with only a single corrective weight or splitting two weights at the same radial location.

TDC - an acronym for top-dead-center, also referred to as the 12 o'clock position.

Weight Planes - the location for corrective weights.

1750/1800 FUNCTIONAL CHECK FOR CALIBRATION

