

# COATS®

## 1001 Computer Wheel Balancer



### Installation Instructions Operating Instructions Safety Instructions Maintenance Instructions

READ these instructions before placing unit in service KEEP these and other materials delivered with the unit in a binder near the machine for ease of reference by supervisors and operators.

**HENNESSY INDUSTRIES, INC.**

P.O. Box 3002, 1601 J. P. Hennessy Drive, LaVergne, TN USA 37086 615/641-7533 800/688-6359

HENNESSY INDUSTRIES INC. Manufacturer of AMMCO®, COATS® and BADA® Automotive Service Equipment and Tools.

Manual Part No.: 8143259

Revision: 01/01 rev. 2

# Direct Drive

# Contents

## Table of Contents

<b>Operator Protective Equipment</b> .....	<b>iv</b>
<b>Owner's Responsibility</b> .....	<b>v</b>
<b>Definitions of Hazard Levels</b> .....	<b>v</b>
<b>Important Safety Instructions</b> .....	<b>vi</b>
<b>Specifications</b> .....	<b>1</b>
<b>Power Requirements</b> .....	<b>1</b>
<b>Standard Package</b> .....	<b>1</b>
<b>Installation and Setup</b> .....	<b>2</b>
Floor and Space Requirements .....	2
Unpacking .....	2 - 3
Hood and Pod Set-up .....	3
Electrical Power .....	4
Precautions .....	4
Initial Testing .....	5
New Features of (C) 1985 Microprocessor .....	5
<b>Balancing Procedure</b>	
Display Board Layout .....	6
1. Mount Wheel .....	6
2. Offset .....	7
3. Rim Width .....	8
4. Rim Diameter .....	9
5. Spin Mode .....	10
6. Take Readings .....	10
7. Attach Weight .....	10
<b>Balancing Special MAG Wheels (Adhesive Weights)</b> .....	<b>11</b>
1. Two Adhesive Weights (Outside Weight Visible) .....	11
2. Standard Clip Weight - One Adhesive Weight (Hidden Method) .....	12
3. Two Adhesive Weights (Hidden Method) .....	12
Static Balancing (Adhesive Weight) .....	13
<b>Wheel Mounting Options</b>	
Back Cone Mounting .....	14
Light Truck Cone .....	14
<b>Special Problems</b> .....	<b>15</b>
<b>Calibration</b>	
Calibration Check Procedure .....	15
Calibration Adjustment Procedure .....	16
<b>Optional Combi Adaptor</b> .....	<b>16 -17</b>
<b>Preventive Maintenance</b> .....	<b>17</b>

# Safety



**Failure to follow danger, warning, and caution instructions may lead to serious personal injury or death to operator or bystander or damage to property. Do not operate this machine until you read and understand all the dangers, warnings and cautions in this manual. For additional copies of either, or further information, contact:**

**Hennessy Industries, Inc.**

P.O. Box 3002, 1601 J.P. Hennessy Drive  
LaVergne, TN 37086-1982  
(615) 641-7533 or (800) 688-6359  
[www.Hennessy-Ind.com](http://www.Hennessy-Ind.com)

## **Operator Protective Equipment**

Personal protective equipment helps make tire servicing safer. However, equipment does not take the place of safe operating practices. Always wear durable work clothing during tire service activity. Loose fitting clothing should be avoided. Tight fitting leather gloves are recommended to protect operator's hands when handling worn tires and wheels. Sturdy leather work shoes with steel toes and oil resistant soles should be used by tire service personnel to help prevent injury in typical shop activities. Eye protection is essential during tire service activity. Safety glasses with side shields, goggles, or face shields are acceptable. Back belts provide support during lifting activities and are also helpful in providing operator protection. Consideration should also be given to the use of hearing protection if tire service activity is performed in an enclosed area, or if noise levels are high.

## **Important Information**

**Rubber Manufacturers Association**

1400 K Street N. W.  
Washington, DC 20005  
(202) 682-4800

**Tire Guides, Inc.**

The Tire Information Center  
1101-6 South Rogers Circle  
Boca Raton, FL 33487-2795  
(561) 997-9229  
[www.tireguides.com](http://www.tireguides.com)

# Safety

## Owner's Responsibility

To maintain machine and user safety, the responsibility of the owner is to read and follow these instructions:

- Follow all installation instructions.
- Make sure installation conforms to all applicable Local, State, and Federal Codes, Rules, and Regulations; such as State and Federal OSHA Regulations and Electrical Codes.
- Carefully check the unit for correct initial function.
- Read and follow the safety instructions. Keep them readily available for machine operators.
- Make certain all operators are properly trained, know how to safely and correctly operate the unit, and are properly supervised.
- Allow unit operation only with all parts in place and operating safely.
- Carefully inspect the unit on a regular basis and perform all maintenance as required.
- Service and maintain the unit only with authorized or approved replacement parts.
- Keep all instructions permanently with the unit and all decals/labels/notices on the unit clean and visible.
- Do not override safety features.
- If ownership of the unit is transferred, provide new owner all information, manuals, and provide COATS new ownership information.

## Definitions of Hazard Levels

Identify the hazard levels used in this manual with the following definitions and signal words:

### DANGER

Watch for this symbol:



It Means: Immediate hazards, which will result in severe personal injury or death.

### WARNING

Watch for this symbol:



It Means: Hazards or unsafe practices, which could result in severe personal injury or death.

### CAUTION

Watch for this symbol:



It Means: Hazards or unsafe practices, which may result in minor personal injury or product or property damage.



Watch for this symbol! It means BE ALERT! Your safety, or the safety of others, is involved!

# Safety

## IMPORTANT SAFETY INSTRUCTIONS

### READ ALL INSTRUCTIONS

1. Eye and face protection recommendations:  
“Protective eye and face equipment is required to be used where there is a reasonable probability of injury that can be prevented by the use of such equipment.” O.S.H.A. 1910.133(a) Protective goggles, safety glasses, or a face shield must be provided by the owner and worn by the operator of the equipment. Care should be taken to see that all eye and face safety precautions are followed by the operator. ALWAYS WEAR SAFETY GLASSES. Everyday glasses only have impact resistant lenses, they are not safety glasses.
2. Do not disable hood safety interlock system, or in any way shortcut safety controls and operations.
3. Be sure that wheels are mounted properly, the hub nut engages the arbor for not less than four (4) turns, and the hub nut is firmly tightened before spinning the wheel.
4. Read and understand this manual before operating. Abuse and misuse will shorten the functional life.
5. Be sure the balancer is properly connected to the power supply and electrically grounded.
6. Do not operate equipment with a damaged cord or if the equipment has been dropped or damaged – until it has been examined by a qualified serviceman.
7. Do not let cord hang over edge of table, bench, or counter or come in contact with hot manifolds or moving fan blades.
8. If an extension cord is necessary, a cord with a current rating equal to or more than that of the equipment should be used. Cords rated for less current than the equipment may overheat. Care should be taken to arrange the cord so that it will not be tripped over or pulled.
9. Keep guards and safety features in place and in working order.
10. Wear proper clothing. Safety toe, non-slip footwear and protective hair covering to contain hair is recommended. Do not wear jewelry, loose clothing, neckties, or gloves when operating the balancer.
11. Keep work area clean and well lighted. Cluttered and/or dark areas invite accidents.
12. Avoid dangerous environments. Do not use power tools or electrical equipment in damp or wet locations, or expose them to rain.
13. Avoid unintentional starting. Be sure the balancer is turned off before servicing.
14. Disconnect the balancer before servicing.
15. Use only manufacturer’s recommended accessories. Improper accessories may result in personal injury or property damage.
16. Repair or replace any part that is damaged or worn and that may cause unsafe balancer operation. Do not operate damaged equipment until it has been examined by a qualified service technician.
17. Never overload or stand on the balancer.
18. Do not allow untrained persons to operate machinery.
19. To reduce the risk of fire, do not operate equipment in the vicinity of open containers or flammable liquids (gasoline).
20. Adequate ventilation should be provided when working on operating internal combustion engines.
21. Keep hair, loose clothing, fingers, and all parts of body away from moving parts.
22. Use equipment only as described in this manual.
23. Use only manufacturer’s recommended attachments.

## SAVE THESE INSTRUCTIONS

# Direct Drive

## Specifications

- 5/16 Allen Wrench
- Single spin dynamic/static, twin plane.
- Vertical wheel mounting.
- Backcone and light truck cone mounting systems standard.
- Accuracy  $\pm 0.1$  ounce (or  $\pm 3$  gram).
- Exclusive direct drive system (no belt - no pulleys).
- Forced air cooling.
- Cycle time - 4 1/2 seconds (standard tire).
- Rim diameter 10-17 inches.
- Fully interlocked guard hood (safety feature).
- Maximum tire diameter 42 inches.
- Shipping Weight 650 lbs.
- Fewest moving parts of any balancer.
- Large dials for data entry.
- "No bolt down" installation.
- Static/mag feature.
- Large readout in 1/4 ounce or 1/10 ounce or gram increments.
- Greater distance from shaft to machine (better for front wheel drive application).
- 1 1/2 H.P. modified torque motor:
  - Large housing for heat dissipation.
  - Motor insulation - heavy duty for high temperature application.
  - Motor rated for 900 RPM use.
- Oversized weight bins.
- Standard adapters fit.
- ABS hood.
- Removable shaft for closed-center wheels.
- Control panel positioned for best visibility.
- Easy to read position lights.
- Scratch resistance surface.
- On-Off switch.
- Electronics isolated from motor heat.
- Simple calibration.
- Automatic rim gauge return.
- Strategically numbered dials for easy reading.
- 6-12-24 month guarantee.

## Power Requirements

Standard:	Optional:	(Factory Installed)
220 VAC	115 VAC	220 VAC
20 AMPS	20 AMPS	20 AMPS
60 Hz	60 Hz	60 Hz
3 Phase	1 Phase	1 Phase

## Standard Package

Includes balancer with built-in 17 bin weight tray, interlocked guard hood, passenger car backcone mounting system and light truck cone, 6 accessory pegs, instruction manual, wheel weight tool and calipers.

# Direct Drive

## Installation and Setup

A factory trained COATS® Service Technician must perform the install, setup, and initial test procedures on your 6401 balancer. Do not attempt to install and setup the unit yourself. Accurate and reliable operation of your unit depends on proper installation. Please contact COATS® directly at 1-800-688-9240 for the Certified Service Partner nearest you.

## Floor and Space Requirements

The balancer must be located on a flat floor of solid construction, preferably concrete. The balancer must sit solidly on its three feet. If the balancer is not level, does not sit solidly on its three feet, or is placed on an unstable floor, the balancer will not function properly and will produce inaccurate balance readings.

Do not operate the balancer when it is still bolted down or while it is on the pallet.

Select a location for the balancer that provides a level, solid floor, and adequate clearance around and above the balancer. Make sure the location selected has enough room above and behind the unit so the hood can be raised completely. The location must also provide working room for mounting and removing wheels.

## Unpacking

Check carton and pallet for crushed corners, broken slats, gouges, and punctures which may indicate hidden damage. Make a note of all external damage on the receiving waybill. Freight damage is the responsibility of the delivering carrier.

Initial testing and training are provided by our COATS® distributor.

Remove outer carton from pallet. Remove strapping holding hood in shipping position. Locate and remove accessories. Notify manufacturers representative of any missing accessories that were ordered.

Perform HOOD AND POD SET-UP.

Remove the single lag bolt and loosen the two (2) anchor bolts holding the balancer to the pallet. Locate and install the top two (2) accessory pegs. Carefully slide the balancer off the pallet and move to final location.



**Do not use the control pod, control pod arm, faceplate, hood or stub shaft to lift the balancer.**

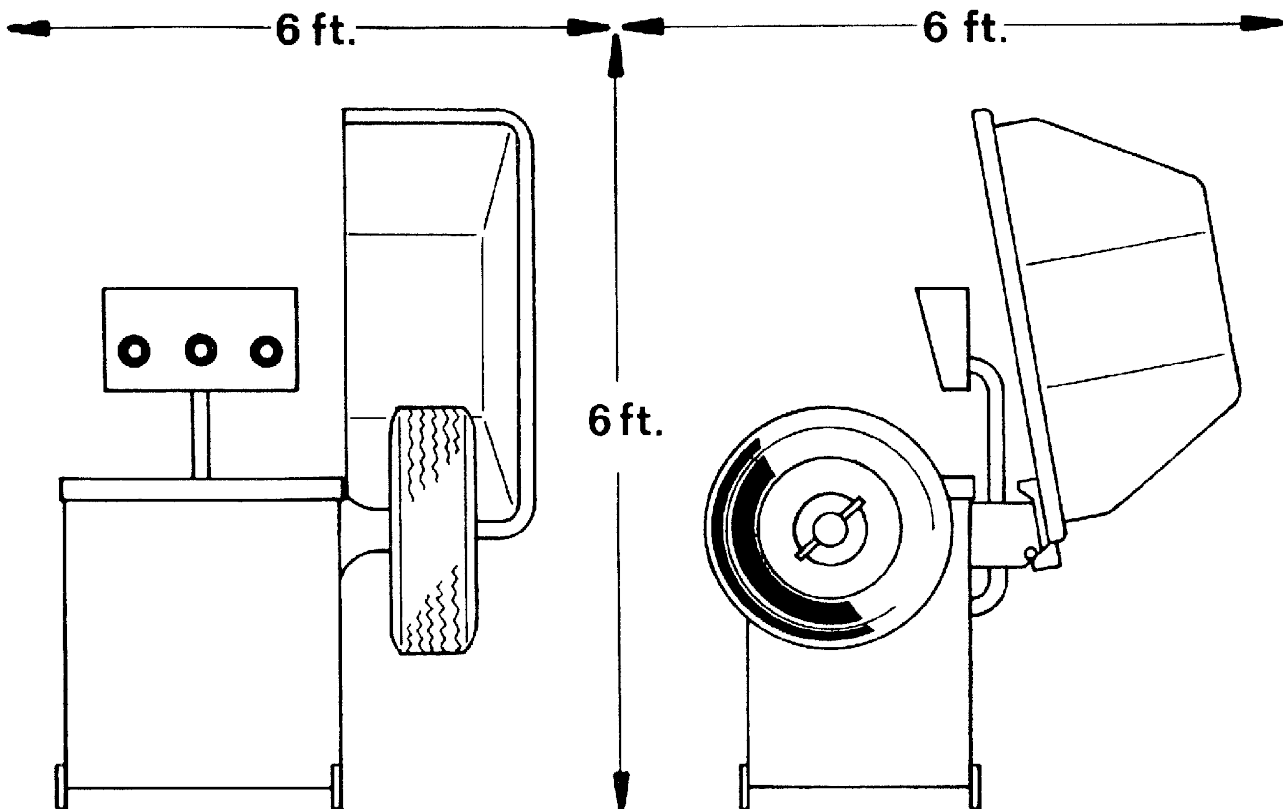

# Direct Drive

Install and tighten the four (4) remaining accessory pegs and hang the accessories.

**Note:** Balancer will not operate properly on pallet.

## Hood and Pod Set-up

To set up hood: Locate hood stop in accessory box and install as shown. Install hood spring as shown. Do not install hood spring until Control Pod has been set up.

Control Pod Setup: Carefully hold control Pod and Post while removing 4 retaining screws. Swing Pod upright as shown above and tightly reinstall the 4 screws. Now attach hood spring from hood bar pin to base.

**Note:** Certain models will have the control pod already in its operating position when received.



**DO NOT drop Control Pod when removing the 4 screws.**

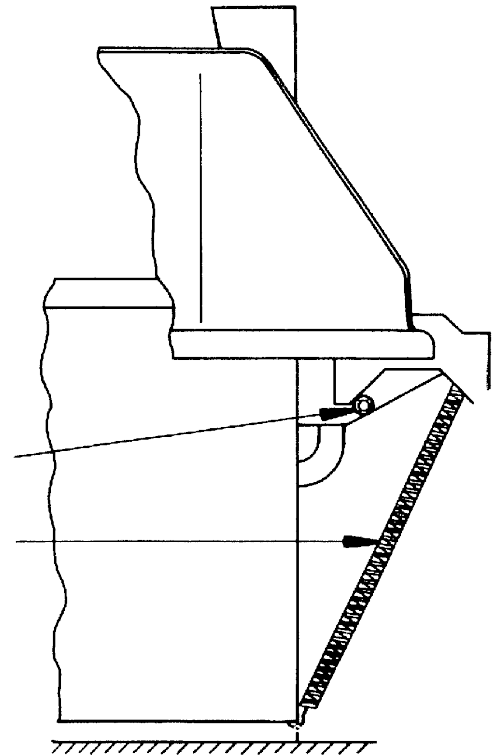
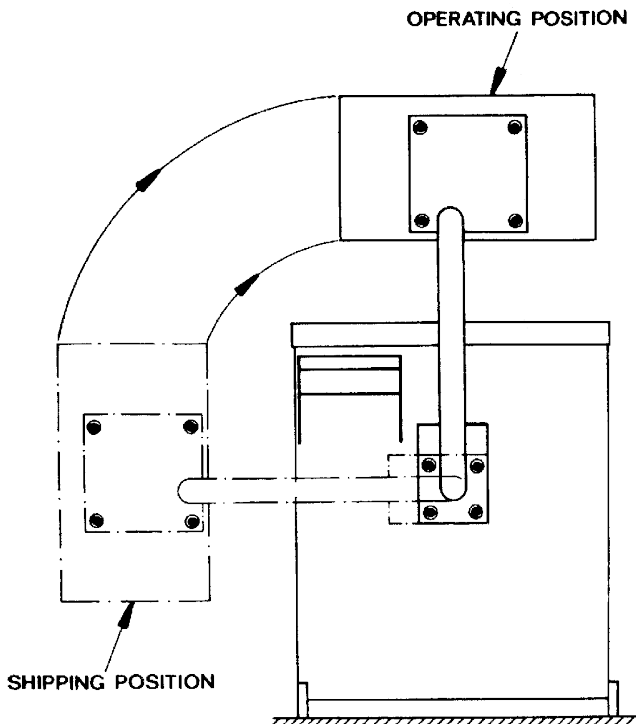

# Direct Drive

## Electrical Power

Consult a licensed electrical contractor for proper installation to local electrical codes. Power outlets must be enclosed in a floor raceway or overhead drop if pedestrian or equipment traffic can damage existing power cord.

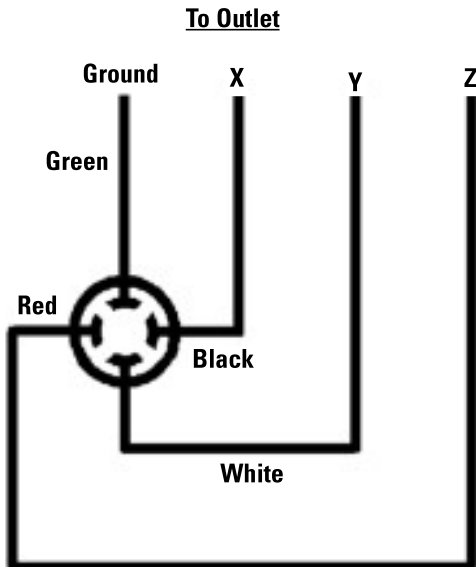

**Operation with a defective ground circuit will create a shock hazard for the operator and could damage the balancers electronics. Operation with a defective ground circuit may void warranty.**

## Precautions

Check voltage requirements on balancer ID plate. Balancer requires nominal 220VAC, 60 Hz, three-phase power with a 20-ampere fuse or circuit breaker. Mating outlet (not furnished) is Hubbel 2420 or Bryant 71520, connected as shown below. A factory installed option is available allowing operation from 115 VAC, single-phase power. A 20 ampere fuse or circuit breaker and a standard three-pin safety outlet wired as shown below is required. Electric outlets must have a solid connection (less than one ohm between ground and pin and building ground).

Voltage Reading Between:	220V Type
X - Y	200 - 250
X - Z	200 - 250
X - Z	200 - 250

Voltage Reading Between:	220V Type
A - B	105 - 130

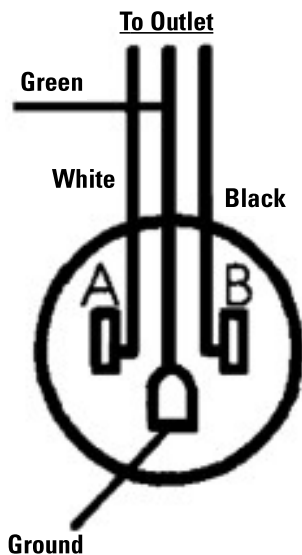

Power and ground requirements must be verified by installer or inspector before connecting balancer. Failure to observe this precaution may void warranty.

If balancer is bolted down, a licensed electrical contractor must be consulted. Most electrical codes require "hard" wiring when balancer is bolted down.

Consult a licensed electrical contractor for proper installation to local electrical codes. Power outlets must be enclosed in a floor raceway or overhead drop if pedestrian or equipment traffic can damage existing power cord.

# Direct Drive

## Initial Testing

Initial testing and training are provided by your COATS distributor. Complete instructions for unpacking and installing your balancer are contained in the INSTALLATION AND SETUP section of this manual.

**Precautions:** Initial testing should be performed by instructor. Power requirements must be verified by installer or instructor before connecting balancer. Failure to observe this precaution may void warranty.

**Power:** Plug power cable into power outlet receptacle. Set circuit breaker in building breaker panel ON. Set ON-OFF switch ON. Leave power on during working day.

**Cooling Air:** Check to verify cooling air blower is running. Do not operate Unit unless cooling air flow is present.

**Spin:** (Standard 220 VAC 3-phase units.) Press START button with hood down. Faceplate should rotate clockwise. If initial direction of faceplate rotation is incorrect, set ON-OFF switch OFF. Set building circuit breaker OFF. Interchange X-Y wires in outlet plug. Set building circuit breaker ON, set ON-OFF switch ON. Press START button. Faceplate initial rotation should be clockwise when facing faceplate.

**Spin:** (Alternate 115 VAC single-phase Units.) Press START button with hood down. Faceplate should rotate clockwise for an Interval and then stop.

If the above conditions cannot be obtained during initial test, call the distributor for service advice.

## New Features of (C) 1985 Microprocessor

1. "HUB" error message if wheel comes loose or no wheel.
2. "rr" error message if wheel goes up to speed in reverse direction.
3. Display dims after 3 minutes if wheel is stationary.
4. "HI-ACC" active only when button held down. Initiated by static and mag or by pushing start button 3 times.
5. Duty cycle display more accurate.

For all 1001 boards with S/N greater than 506625.

# Direct Drive

## Balancing Procedure

### Display Board Layout

1. Start button
2. INNER weight display.
3. INNER position display.
4. OUTER position display.
5. OUTER weight display.
6. STATIC balance button.
7. "MAG" balance button.
8. Wheel diameter (D) knob.
9. Wheel width (W) knob.
10. Wheel offset (A) knob.

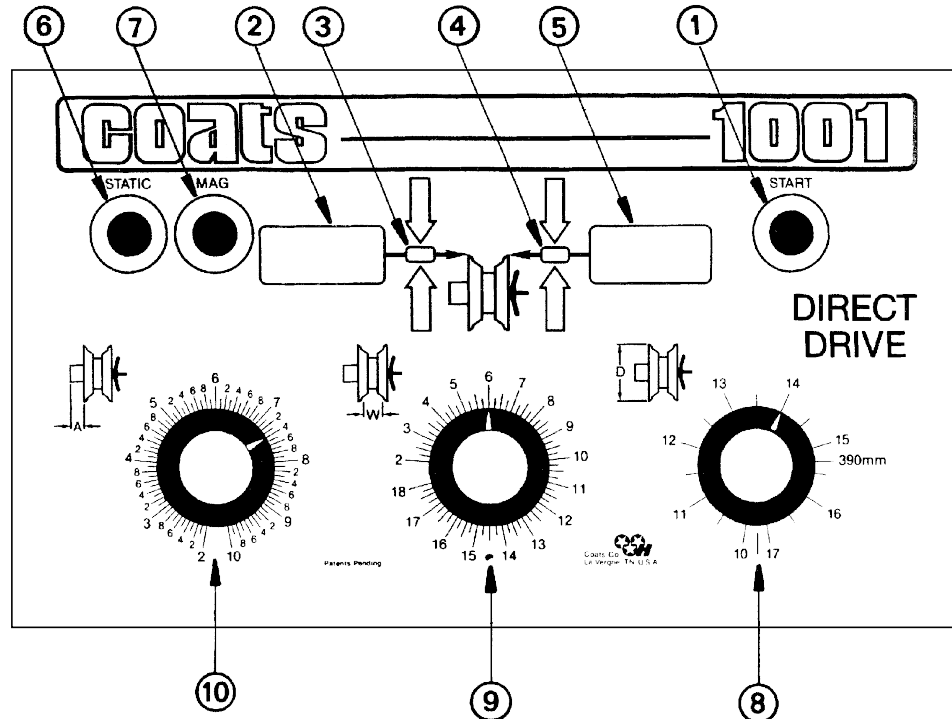

### Leave balancer power on all day.

Static power use is approximately 70 watts.

#### 1. Mount Wheel

Select proper adapter. Adapter selected should center wheel the same as the wheel is centered on the vehicle.

Almost all wheels, including aftermarket or "mag" wheels, can be mounted using the standard back-cone mounting kit.

Light truck wheels can be mounted using The standard light truck cone. Aftermarket wheels with larger than OE center holes can be mounted using lug adapters.

Wheels that center off the lug pattern, i.e., 68 and older VW, Peugeot, etc., can be mounted using the optional lug adapter.



**The hubnut or lug nut threads must engage four full turns. Rotate wheel while tightening to ensure centering. Failure to tighten hubnut securely may result in serious personal injury.**

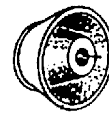
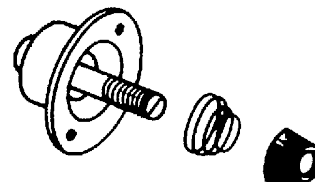

# Direct Drive

## 2. Offset

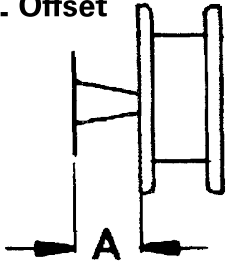

1

Enter offset distance with this knob.

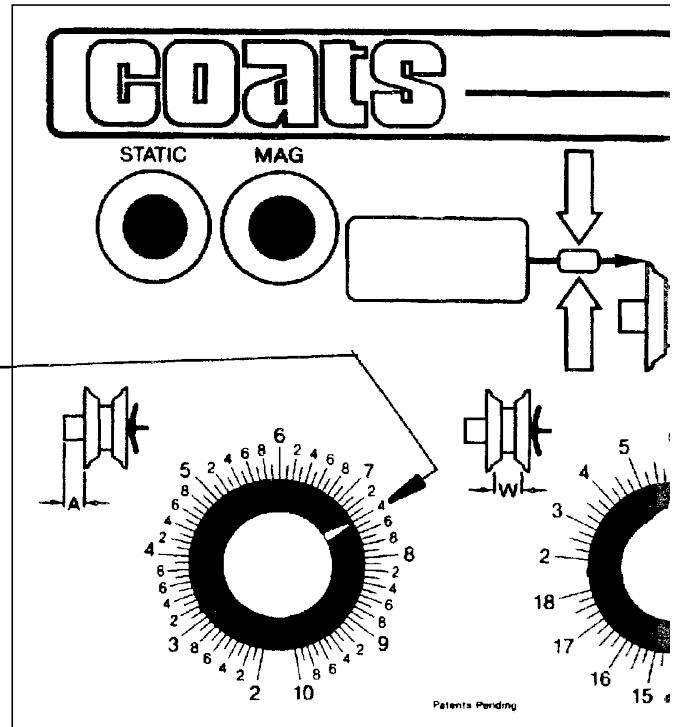

2

Move distance gauge to touch edge of wheel.

3

Enter this distance measurement with offset (A) knob. (Shown in Fig. 1).

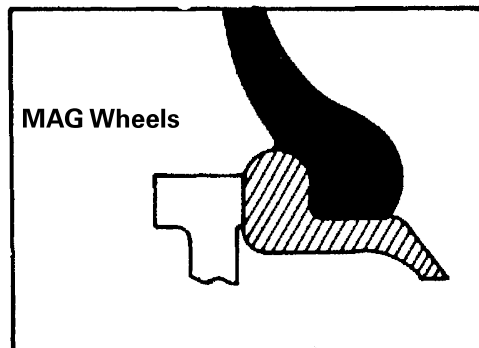
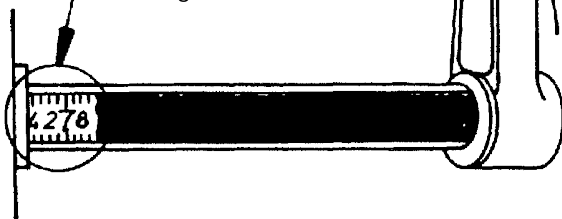

Setup for hidden weights on "mag" is the same as for standard wheels.

# Direct Drive

## 3. Rim Width

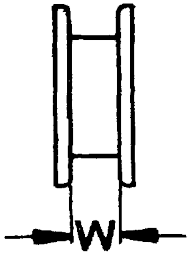

1

Enter wheel width information with this knob.

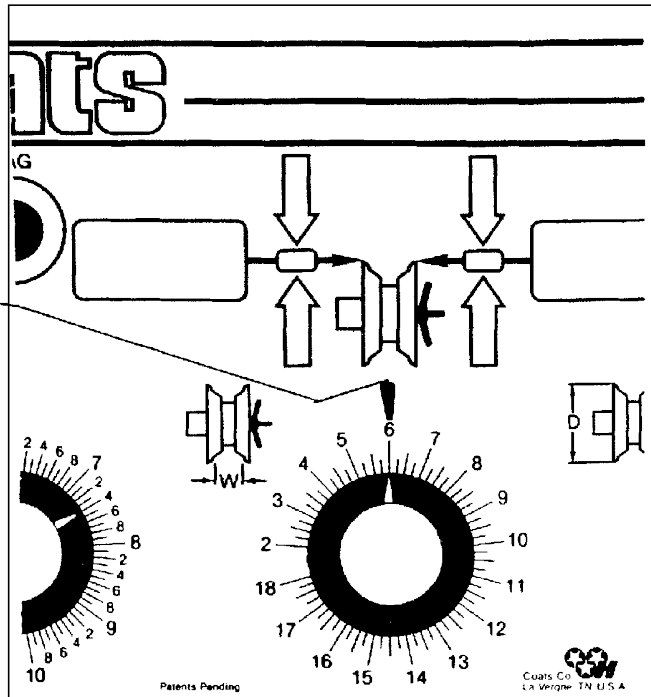

2

Use rim width calipers to measure wheel at points shown.

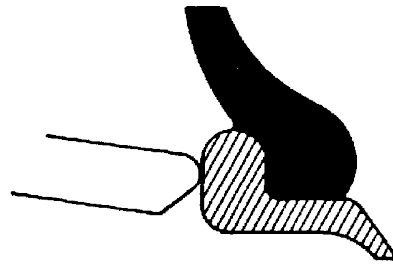
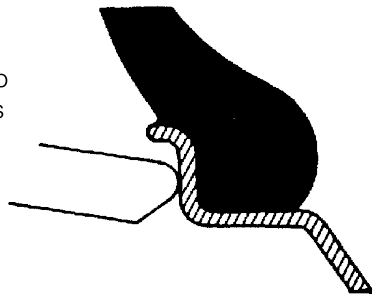

### MAG Wheels

Setup for hidden weights on "mag" wheels is the same as for standard wheels.

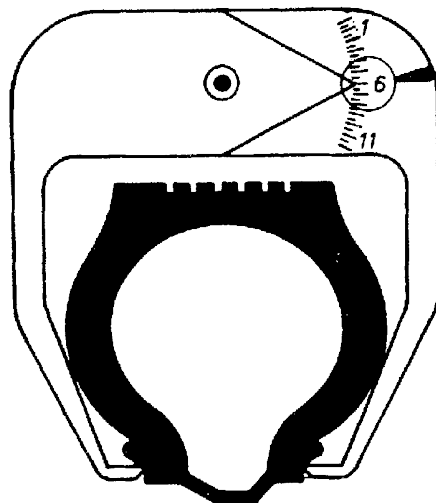

3

Enter this width reading with the width (W) knob. (Shown in Fig. 1).

# Direct Drive

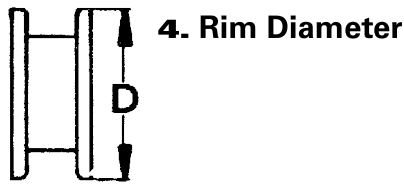

① Enter rim diameter size as read from tire sidewall.

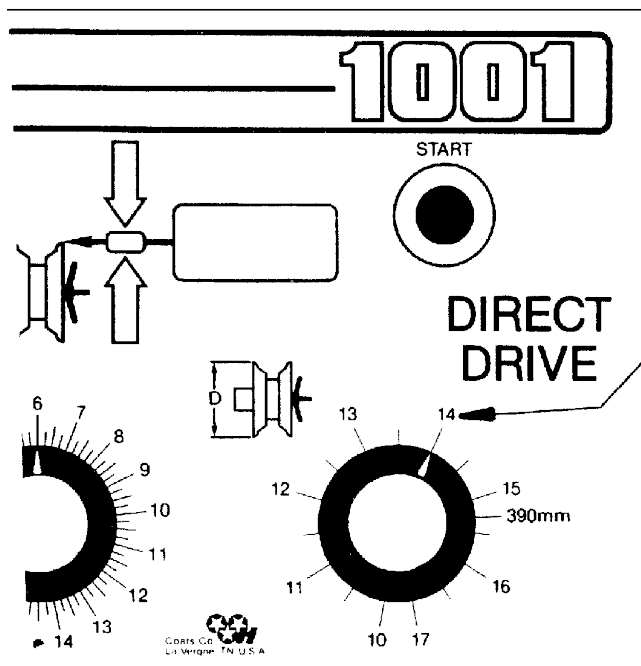
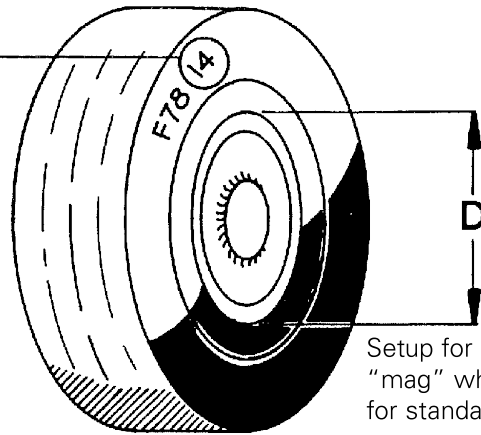

② Enter this diameter reading with the diameter (D) knob. (Shown in Fig. 1).

# Direct Drive

## 5. Spin Mode



**Lower Guard Hood Before Starting Spin.**

Press start button to obtain normal readings. Balancer will spin and stop automatically.

## 6. Take Readings

Weight and position readings will appear on displays as balancer is braking tire.

**FINE BALANCE (for unbalance of 0.2 ounce or less):** hold button down during spin cycle. Position readings will always appear. (Not needed in normal use.)

## 7. Attach Weight

1. Rotate wheel until right (OUTER) twin lights blink alternately.
2. Attach a weight equal to outer weight reading to outer rim at top dead center. (See #2)
3. Rotate wheel until left (INNER) twin lights blink alternately.
4. Attach a weight equal to inner weight reading to inner rim at top dead center. (See #4)

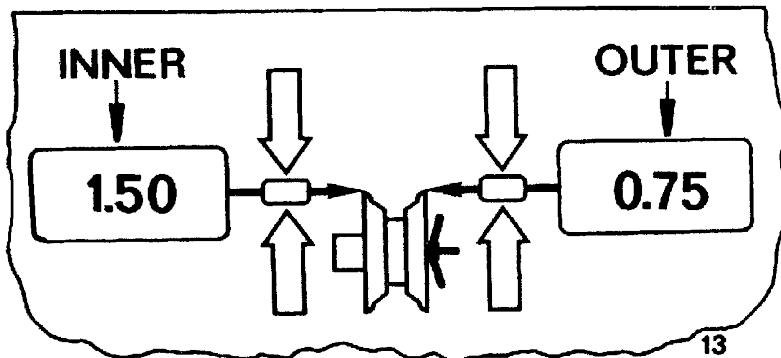
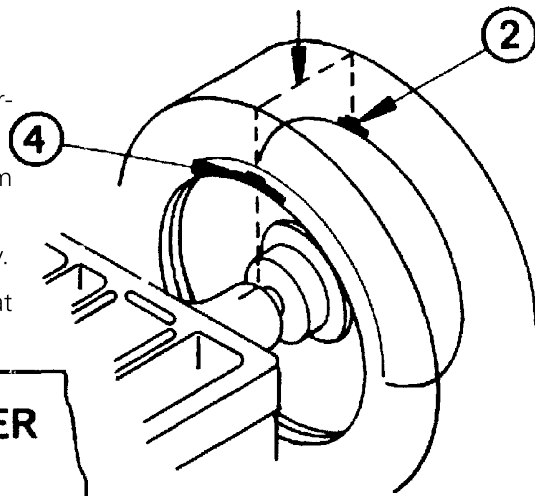

**Note:** The more accurate you are in selecting the exact weight and position, the more often you will balance in one spin. Respin after applying weights to obtain 0.00 reading.

# Direct Drive

## Balancing Special MAG Wheels (Adhesive Weights)

If standard clip weights are to be used, balance as a "standard" wheel. The mag button is used when some specialty wheels are to be balanced or when adhesive weights are required (i.e., hidden weight method).

**Note:** Some specialty wheels do not require the hidden weight method of balancing. See example 2. If adhesive weights must be used, follow these instructions.

See examples 1, 2 and 3 and select how weights will be applied.

Set distance gauge, wheel width, and wheel diameter as indicated in the proper example.

Lower hood and push appropriate button.

Read weight amount and locate position as with a "standard" wheel.

Raise hood. Apply required weights.

Lower hood. Push appropriate button and check weight application.

**Note:** Since hiding adhesive weights involves approximations to actual wheel width and wheel diameter, additional spins may be required. Simply respin and apply weights as called for.



**Be sure wheel surfaces are clean as per adhesive weight manufacturer's recommendations. Apply weight securely, failure to do so may cause weights to come loose resulting in serious personal injury.**

### 1. Two Adhesive Weights (Outside Weight Visible)

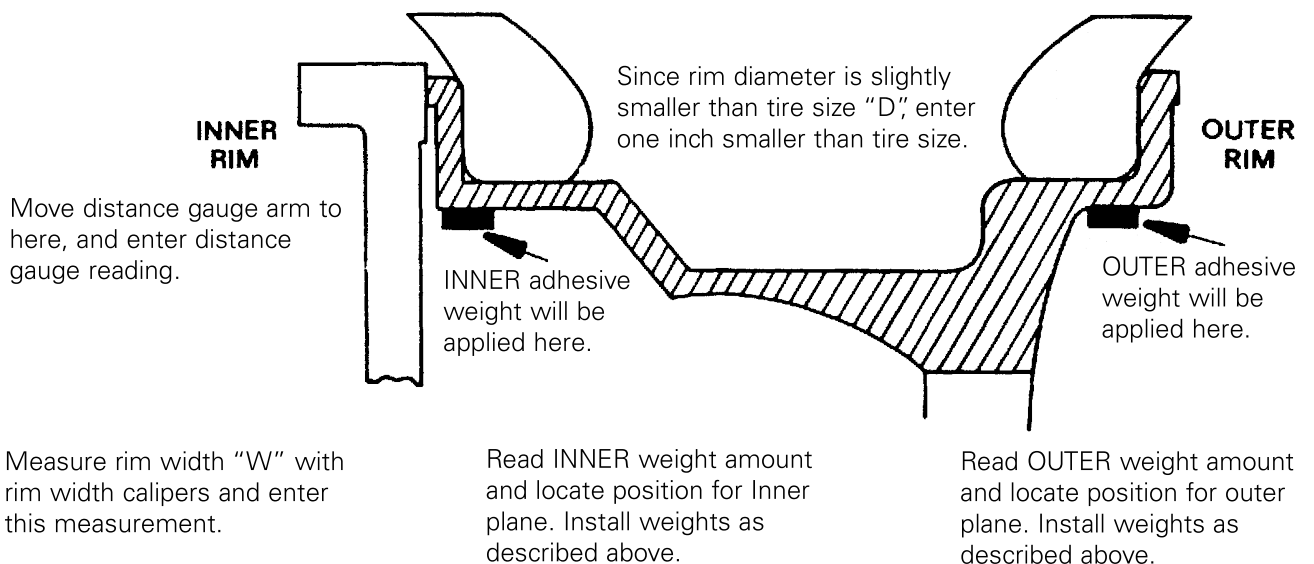

**Note:** Be sure adhesive weights will clear disc brake calipers.

# Direct Drive

## 2. Standard Clip Weight - One Adhesive Weight (Hidden Method)

**MAG**

Use Mag Button.

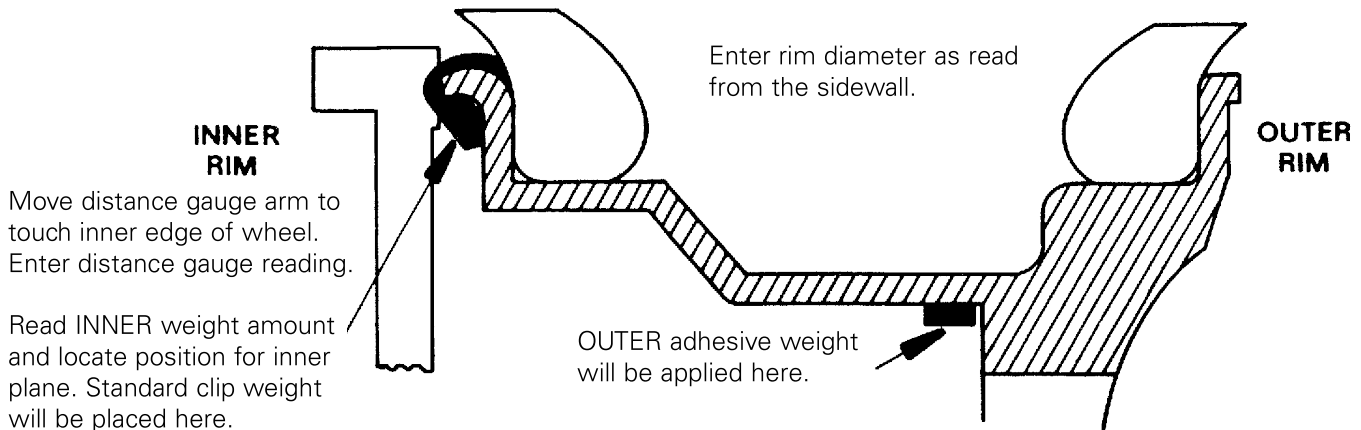
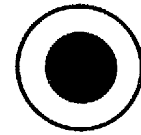

Measure rim width "W" with rim width calipers and enter this measurement.

Read OUTER weight amount and locate position for outer plane, Install weight as described on page above.

**Note:** Be sure adhesive weights will clear disc brake calipers.

## 3. Two Adhesive Weights (Hidden Method)

**MAG**

Use Mag Button.

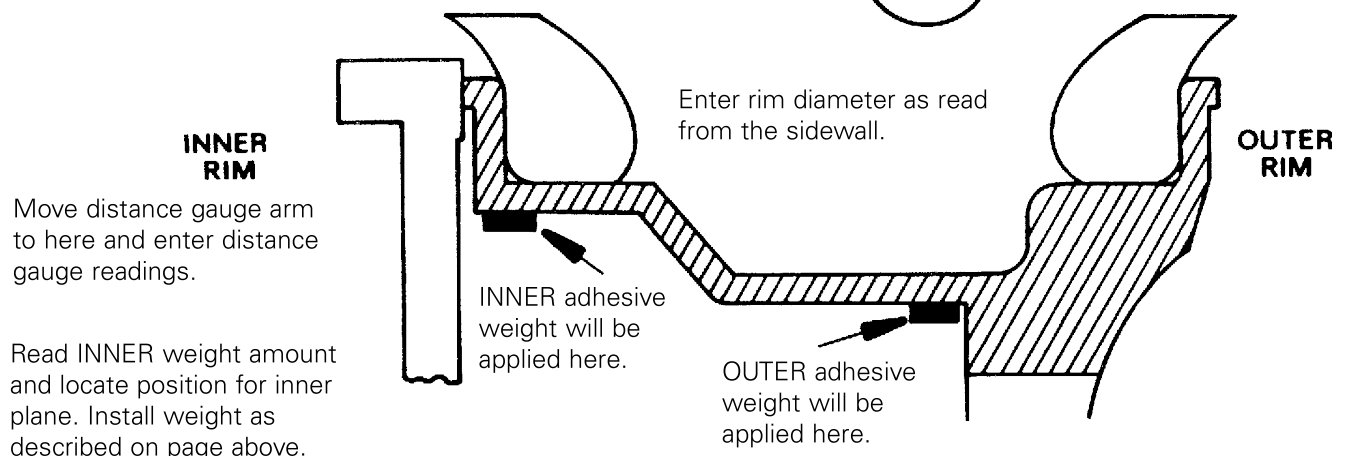
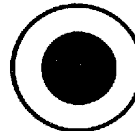

Measure rim width "W" with rim width calipers and enter this measurement.

Read OUTER weight amount and locate position for outer plane. Install weight as described on above.

**Note:** Be sure adhesive weights will clear disc brake calipers.

# Direct Drive

## Static Balancing (Adhesive Weight)

**Note:** This method should *only* be used when the customer requests no visible weights (outer plane) and there is a caliper clearance problem on the inner plane.

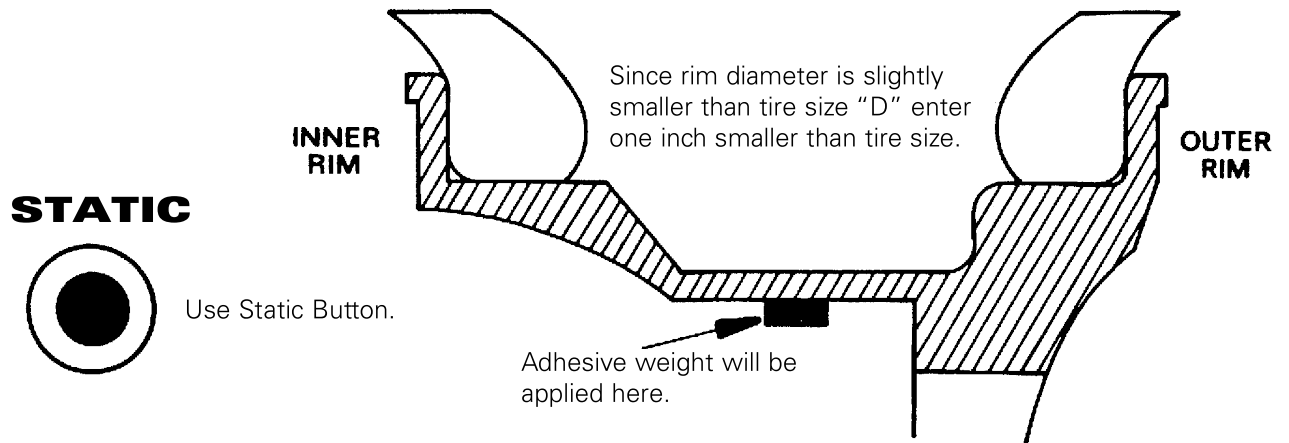

**Note:** Since Static balancing is not as good as twin-plane (Dynamic/Static) balancing, the offset (A) and width (W) knobs do not have to be set.

Read INNER weight amount and locate position for static imbalance. Install weight as described on above.

**Note:** Be sure adhesive weights will clear disc brake calipers.

# Direct Drive

## Wheel Mounting Options

### Back Cone Mounting

1. Place spring over threaded stud with the large end inside of the faceplate.
2. Select a cone that best fits into wheel center hole.
3. Slide selected cone onto threaded shaft with the large end against the spring.
4. Lift wheel onto shaft and center on cone.



Cone centers wheel—Cone must be centered in wheel center hole before tightening.

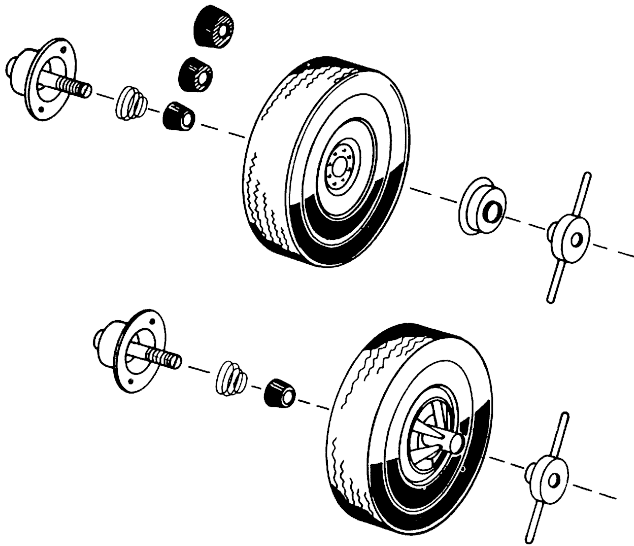

The wheel must be forced firmly against the faceplate. Thread hubnut on and tighten by rotating wheel and striking both arms of hubnut with palm of hand. Hubnut must engage threads for at least four full turns. Failure to tighten hubnut securely may result in serious personal injury.

### Light Truck Cone



Cone must be centered in wheel center hole before tightening. Thread hubnut on and tighten by rotating wheel and striking both arms of hubnut with palm of hand.

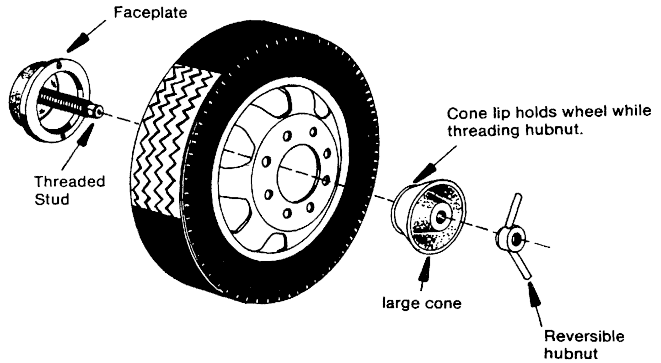

Hubnut must engage threads for at least four full turns. Reverse hubnut when necessary. Hubnut and cone must force wheel firmly against faceplate. Failure to tighten hubnut securely may result in serious personal injury.

# Direct Drive

## Special Problems

Customers will occasionally complain of vibration on the car after balancing. Some possible causes are listed below:

- 1.** Beads improperly seated. Check bead seating and inflation pressure before balancing spin.
- 2.** Stiffness variations in radial belts.
- 3.** Tire out of round; wheel out of round, bent, or not running true. Visually check runout of wheel and tire during balance spin. Re-check mounting. Replace wheel or tire if necessary.
- 4.** Suspension wear, misalignment, or loose vehicle components.
- 5.** Wheels not correctly centered due to damaged hub, damaged or worn center hole, worn bolt circle holes, or imprecise original design. Check wheel run out before balance spin and on the vehicle after mounting.
- 6.** Sensitive suspensions. Use FINE BALANCE (See page 10).

**Complaint:** Balancer uses too many weights or several spins to balance.

**Remedy:** Recheck rim dimensions entered. Position the weights exactly top dead center when green position lights are on.

**Complaint:** Weight or position readings fluctuate.

**Remedy:** Check cone/hubnut for slippage. Check that the balancer is resting firmly on three mounting points, floor is flat and stable, and that no tools or weights are between balancer and floor.

## Calibration

### Calibration Check Procedure

The calibration check procedure can be performed by the operator to ensure that the balancer is operating correctly and is properly calibrated. The only purpose of calibration is to trim the balancer to yield single-spin balancing.

**Note:** If the balancer is set up to display weights in grams instead of ounces, then observe the parenthesis (0.00 gram) values in the CALIBRATION CHECK PROCEDURE and the CALIBRATION ADJUSTMENT MODE.

Throughout the calibration, check procedure, keep the start button depressed during each cycle. This is the FINE BALANCE mode which allows the balancer to read in .01 ounce (1 gram) increments.

**1.** Mount a standard domestic 14" x 6" wheel with an F78-14 or 206/75-14 tire using the proper back cone. Ensure that the wheel is not bent or misaligned and that the center hole is free of nicks and burrs.

**2.** Program the distance, rim width, and rim diameter information into the balancer by setting the knobs on the front panel.

**3.** Balance the wheel using FINE BALANCE until 0.00 weight readings appear on INNER and OUTER displays while holding down the start button during the entire cycle.

**4.** After getting 0.00 to appear while holding the start button, change the Rim Diameter adjustment to read 10.5. If any weight reading appears, repeat step 3.

**5.** Return the Rim Diameter adjustment to 14.

**6.** Install a 4 ounce (113 gram) test weight on the outer rim.

**7.** Spin. The new weight reading should be 3.80 to 4.20 ounce (108 gram to 119 gram). Rotate the wheel so that the central position lights on the outer position indicator come on. The test weight should be directly across (at 6 o'clock).

Weight readings on the inner display should be 0.20 ounce (6 gram) or less. (This results from interference between the two balancing planes.)

**8.** Repeat steps 6 and 7 with the 4 ounce (113 gram) test weight on the inner rim.

**9.** If the balancer fails to yield the results required by this procedure, perform the CALIBRATION ADJUSTMENT PROCEDURE.

# Direct Drive

## Calibration Adjustment Procedure

**Note:** Do not perform Calibration Adjustment when motor is excessively hot.

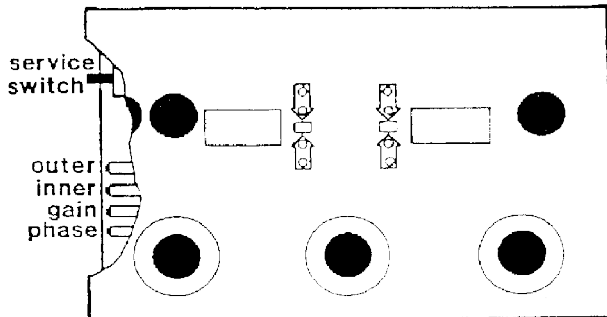

### High Accuracy Mode For Calibration

1. Perform the calibration check procedure steps one (1) through seven (7) (See Page 15).
2. Remove the four (4) screws holding the control panel shroud and lift the shroud off.
3. Place an 8 ounce (226 gram) test weight on outer rim of wheel.
4. Set service switch to upper position (test mode). Press the START button. The display will now read "TEST". The outer and inner position lights will now act as bar graphs. First adjust the gain trimpot until the minimum number of lights are on or flashing. Alternately adjust the gain and phase trimpots until all the lights are off.
5. Set service switch to bottom position (NORM). Remove the test weight and then balance the wheel. A maximum imbalance of .07 ounce (2 gram) on the inner and outer weight displays is allowed.
6. Place a 4 ounce (113 gram) test weight on the outer rim.
7. Set the service switch to center position (non-stop). Press the START button. Wheel will come up to speed, but not go into braking mode. Now adjust the outer weight trimpot (affects outer magnitude). After each adjustment of the trimpot, press and hold the START button until a new reading appears on the display. Continue this procedure until the outer weight display reads 4 ounce (113 gram). The inner weight reading should be .21 ounce (6 gram) or less. Set the service switch to the bottom position so that the wheel will brake to a stop.
8. Place the 4 ounce (113 gram) test weight on the inner rim. Set service switch to center position. Press the START button.

9. Adjust the inner weight trimpot (affects inner magnitude) until display reads 4 ounce (113 gram). Use the same procedure as in Step 7. The outer weight reading should be .21 ounce (6 gram) or less. Set the service switch to the bottom position (NORM).

10. Calibration is now complete. To return the balancer to the normal operating mode: Switch off the power and then turn it on again (On/Off switch located on rear of machine). This clears the high accuracy mode and the balancer is ready to use.

## Optional Combi Adaptor

Combi adaptor may be used for 3, 4, 5, 6, 8, or 10-Lug wheels by installing swivel plates in Combi plate hole pattern. Set up adaptor as follows:

Install a swivel plate in combi plate "common" hole. Line up number gear to match "345" mark with index mark on swivel plate. Insert swivel plate bolt through back of combi plate and run up. DO NOT TIGHTEN.

**Note:** This swivel plate is used for all bolt circle patterns.

Install proper number of swivel plates in combi plate holes marked "3", "4", or "5" as required. Insert swivel plate bolts through back of combi plate and run up, DO NOT TIGHTEN. Ensure that index marks on all swivel plates line up with the appropriate "3", "4", or "5" mark on the number gear.

Install combi adaptor on wheel. Run up lug nuts by hand. Tighten lug nuts with adapter wrench, using a star or criss-cross pattern.



**Lug nuts must be centered and threaded at least four full turns Reverse lug nuts as required. Use only adapter wrench furnished with adapter Do not use air tools or impact wrenches.**

Tighten swivel plate bolts with alien wrench.

Attach wheel and adapter to faceplate with two faceplate nuts.



**Faceplate nuts must be hand tightened. Rotate wheel while tightening to ensure centering.**

Adapter should remain on faceplate for additional wheels with same bolt circle.

# Direct Drive

## Optional Combi Adapter

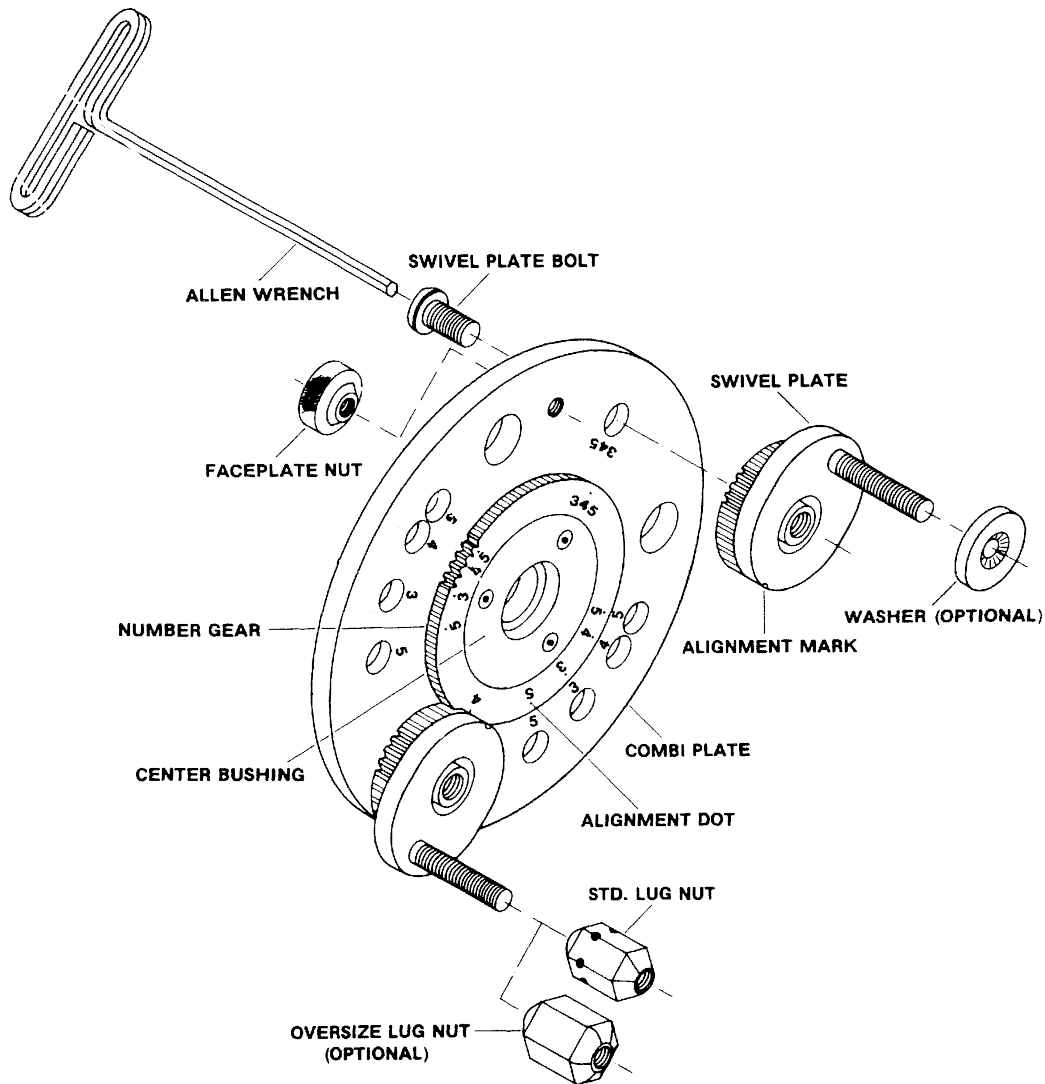

## Preventative Maintenance



**DO NOT** use a solvent which leaves an oil residue.



**NEVER** use compressed air or a water hose to clean any part of your balancer.

**Daily:** Clean shaft and faceplate with a vaporizing solvent. Cones, hubnut and other mounting hardware should be checked/cleaned at this time.

**Monthly:** Clean entire machine. Remove all used weights, tools and parts which may be under, or leaning against balancer. Perform Calibration Check Procedure. Make adjustments only if required.

**Yearly:** Have your COATS authorized service personnel perform the following: Clean Optical Sensor, Clean Fan Motor Air Inlet.

