

Kim Dawson

(503) 824-5888

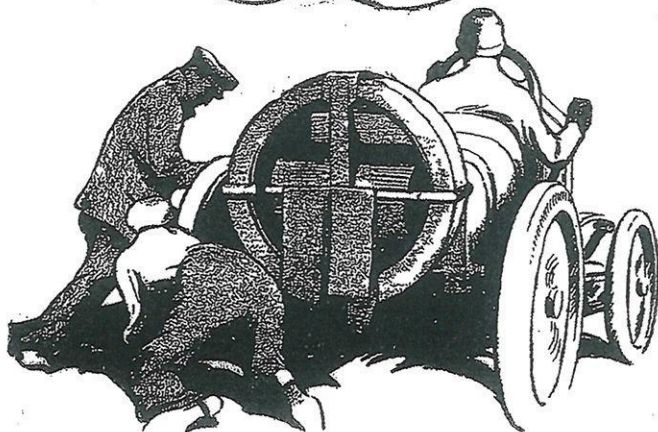

ANTIQUE AUTO  
TOP HARDWARE  
COMPANY



30688 S. MARIAN ST.  
MOLALLA, OR 97038

Authentic Parts  
and Accessories

Round Leather  
Top Stay Straps

Leather Straps and Parts  
Made to Order

In offering this catalog to the restorer, we have ventured to select and reproduce parts that are hard to find, and leather craftsmanship of exceptional quality. If you don't find an item you need in our catalog, please ask and we may make it or locate it for you. Let us make your top our top priority.

**ORDERING:**

This is a mail order business. You are welcome to stop by. Please call first. When ordering, please use part numbers and or description. List year and model of car. I keep a file of ads and articles on early cars and if I have information on your car, I'll send copys. Include the appropriate information sheet for leather parts.

**SHIPPING & HANDLING:**

Please add 10% for shipping and handling or if your domestic order will fit in a flat rate Priority Mail Box, the cost should be no more than \$22. Longer, heavier parts usually adds more to the shipping cost. Minimum shipping charge is \$9. Foreign orders please allow for higher shipping charges.

**SHIPPING ADDRESS:**

Please make sure your street address is on the order. UPS cannot deliver to a post office box. Most orders will be sent USPS Priority Mail.

**TERMS OF PAYMENT:**

Include full payment plus shipping charge in your check or money order. Checks can be made out to Kim Dawson or Antique Auto Top Hardware Company. If you have a special order or are unsure of calculating price, send order and I'll figure cost.

**PRICES:**

I will try to maintain prices in this catalog, but I reserve the right to change prices whenever my cost of supplies increases.

**DELIVERY TIME:**

Hardware orders usually completed and shipped right away. Leather orders usually take a few days. Please don't wait until you need it yesterday. All orders completed promptly.

3

Authentic style top hardware and round leather top stay straps are our specialties. Most parts are made using the investment casting (lost wax) process.

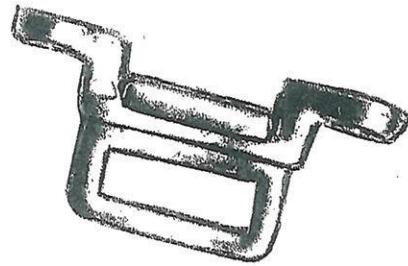

DISCONNECT LINK WITH FOOTMAN, LOOP

Part No. 101  
Overall length 3"  
For 1" strap  
Mounts on front of front top bow allowing quick, easy removal of top stay straps when top is folded. Release lower end of strap, turn link 90 degrees, and slide the link off of one side of the footman loop.  
Bronze  
Link/Loop Set (one link, one loop) \$36

Note about Disconnect Link/Loop: Original parts were cast in iron with a tensile strength of 54,000 psi. These parts are cast in silicon bronze with a tensile strength of 55-65,000 psi.

FRAME BRACKET

Part No. 103  
Overall length 2½"  
Mounts on frame  
Has ½" eye  
Brass

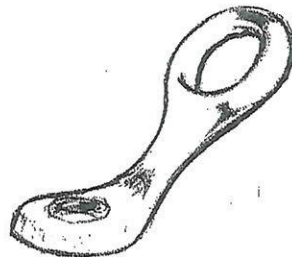

\$18

SNAP LOOP

Part No. 207  
Overall length 2½"  
Mounts on front top bow or on frame.  
Has ½" eye  
Brass

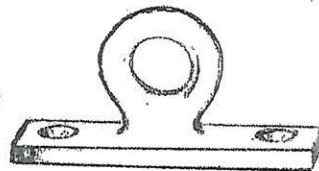

\$18

4

HD SNAP LOOP

Part No. 206  
Overall length 2"  
Width 1½"  
Oval eye ¾" x 9/16"  
Mounts on frame or bow.  
Takes #10 screws  
Brass



\$19

BACK STAY LOOP

Part No. 133  
Overall width 2"  
Mounts on back of body with #10 screws.  
For 1" strap  
Brass

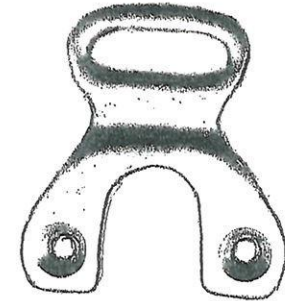

\$19

DOUBLE STRAP LOOP

Part No. 150  
Overall length 2 ¾"  
For two 1" straps  
Mounts on back of body on each side for back stay straps.  
Uses #12 screw  
Brass

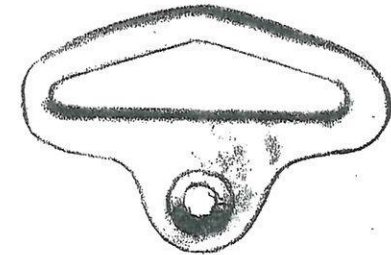

\$19

3-HOLE FOOTMAN LOOP

Part No. 169  
Overall length 3"  
Width 1½"  
For 1¼" or 1½" strap  
Use as hood strap bracket, door strap loop, or on step board.  
Brass



\$20

5

BOLT MOUNT STRAP LOOP

Part No. 111  
For 1" strap  
Takes 1/4" carriage bolt  
or countersunk screw.  
Mounts on front or rear bow  
or on body or frame.  
Brass



\$18

SQUARE STRAP LOOP

Part No. 202  
For 1" strap  
Various uses.  
Brass



\$14

BOW BRACKET

Part No. 104  
Overall length 2 5/8"  
For 1", 1 1/8", or  
1 1/4" strap.  
Mounts on front or rear  
bow, or on step board.  
Brass

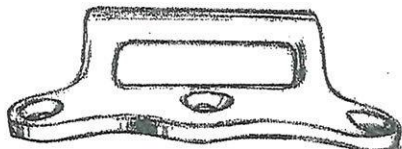

\$20

HOOD STRAP BRACKET

Part No. 105  
Overall length 2 3/4"  
For 1 1/2" strap  
Mounts on frame beside hood  
Brass

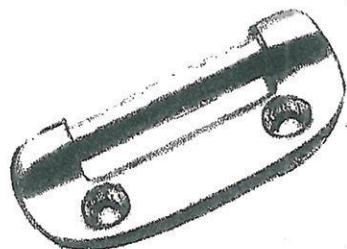

\$22

HOOD STRAP SPRING

Part No. 501  
Overall length 3 5/8"  
For 1 1/2" strap  
Stainless Steel  
Each

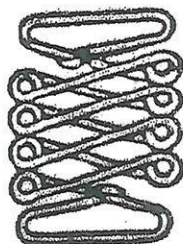

\$26

6

CHECK STRAP BRACKET

Part No. 187  
Width 1"  
Height 1 5/8"  
For 1 3/8" strap or  
1 1/4" strap wrapped  
with Upholstery leather.  
Cast Brass  
Each

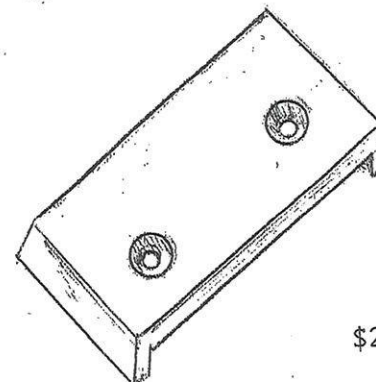

\$22

OFFSET DOOR STRAP LOOP

Part No. 124  
Overall Length 2 1/4"  
For 1 1/4" to 1 1/2" strap  
Various uses  
20s & 30s cars  
Takes #12 screws  
Brass  
Each

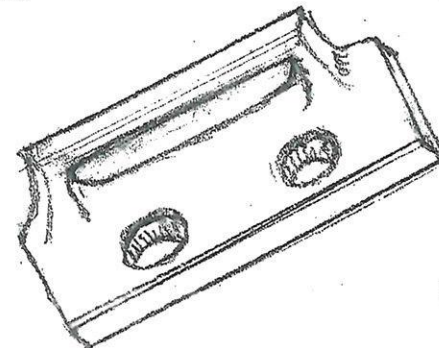

\$22

SMALL FOOTMAN LOOP

Part No. 208  
Overall length 2"  
For 3/4" strap  
Various uses  
Takes #6 screws  
Polished  
Brass

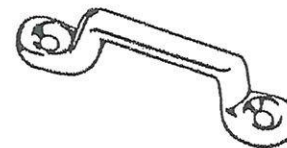

\$5

TALL FOOTMAN LOOP

Part No. 209  
Overall length 2"  
For 3/4" strap  
Polished  
Brass

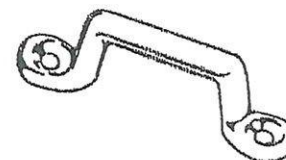

\$5

STAMPED FOOTMAN LOOPS

7



For 1" strap, overall length 2 5/8"

NICKEL Plated Steel For 1" Strap  
Part No. 630 Each \$3

STAINLESS STEEL For 1" Strap  
Part No. 631 Each \$3

PAINTED BLACK For 1" Strap  
Part No. 431 Each \$5

For 1 1/4" strap, overall length 2 3/4"

NICKEL Plated Steel For 1 1/4" Strap  
Part No. 632 Each \$3

STAINLESS STEEL For 1 1/4" Strap  
Part No. 633 Each \$3

PAINTED BLACK For 1 1/4" Strap  
Part No. 433 Each \$5

For 1 1/2" strap, overall length 3 1/8"

NICKEL Plated Steel For 1 1/2" Strap  
Part No. 634 Each \$3

STAINLESS STEEL For 1 1/2" Strap  
Part No. 635 Each \$3

PAINTED BLACK For 1 1/2" Strap  
Part No. 435 Each \$5

For 2" strap, Overall length 3 5/8"

ZINC Plated Steel for 2" Strap  
Part No. 636 Each \$5

PAINTED BLACK For 2" Strap  
Part No. 437 Each \$8

DECO DOOR STRAP LOOP

8

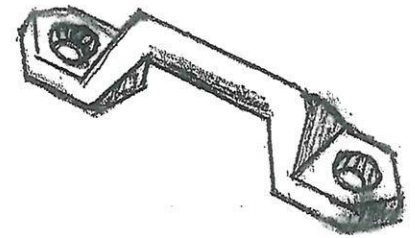

Part No. 123  
Overall Length 3"  
For 1 1/4" strap  
Various uses  
20s cars, Buick, etc.  
Takes #10 screws  
Brass  
Each \$20

HD FOOTMAN LOOPS

Part No. 102  
Overall length 2 3/4"  
For 1" strap  
Various uses  
Takes #10 screws  
Brass \$18

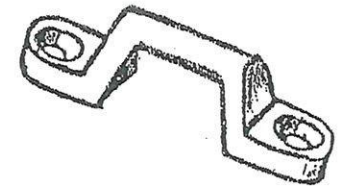

Part No. 110  
Overall length 3"  
For 1 1/4" strap  
Door straps, hood straps  
Various uses  
Takes #10 screws  
Brass \$19

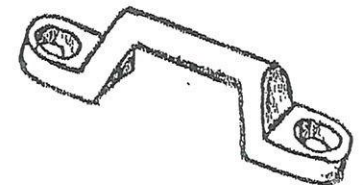

Part No. 109  
Overall length 3 1/4"  
For 1 1/2" strap  
Door straps, hood straps  
Various uses  
Takes #10 screws  
Brass \$20

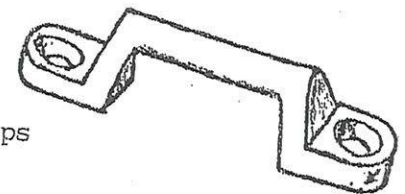

9

TOP BOOT STRAP LOOP

Part No. 156  
Overall length 2 3/4"  
For 1" strap  
Mounts on back of body  
Top boot straps fasten  
on loops, 2 or 3 needed  
Brass

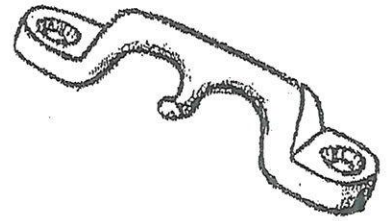

\$18

HD RUNNING LOOP

Part No. 120  
Overall length 2 3/4"  
For 1 1/4" strap  
Holes not countersunk  
Hood straps, trunk straps  
Various uses.  
Low profile.  
Used on Pope hood to  
guide hood straps.  
Brass

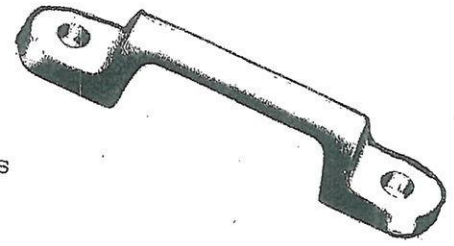

\$18

RUNNING LOOP

Part No. 132  
Overall length 3 1/4"  
For 1 1/2" strap  
Intended to be a guide for  
hood straps or trunk straps.  
Used on Pierce trunk rack.  
Brass

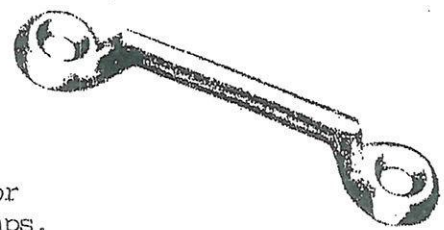

\$18

TALL RUNNING LOOP

Part No. 640  
Overall length 2 5/8"  
For 1" strap  
Clearance 9/16"  
Running loop for 2 straps  
Used on trunks  
Chrome plated steel  
Each

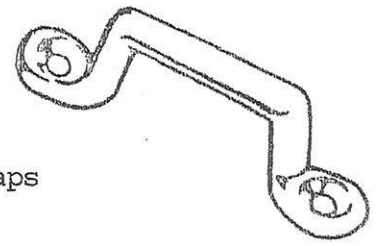

\$8

10

EARLY FOOTMAN LOOPS

Part No. 113  
Overall length 2 3/4"  
For 1" strap  
Mounts on front or rear bow.  
Various uses  
Takes #10 screws  
Brass

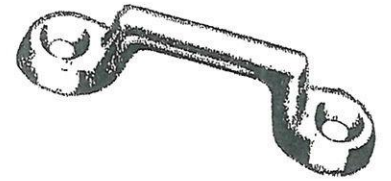

\$18

Part No. 112  
Overall length 3"  
For 1 1/4" strap  
Back stay straps, door  
straps, hood straps.  
Various uses  
Takes #10 screws  
Brass

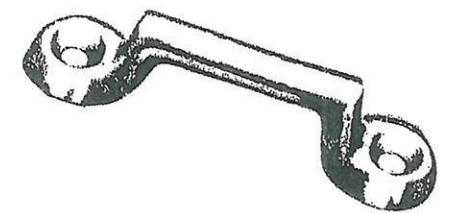

\$19

Part No. 131  
Overall length 3 1/4"  
For 1 1/2" strap  
Various uses  
Pierce door strap loop.  
Takes #12 screws  
Brass

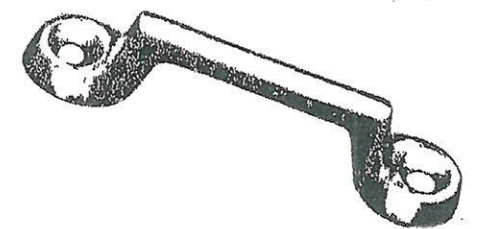

\$20

Part No. 122  
Overall length 3 3/4"  
For 2" strap  
Various uses  
Pope door strap loop.  
Takes #12 screws  
Brass

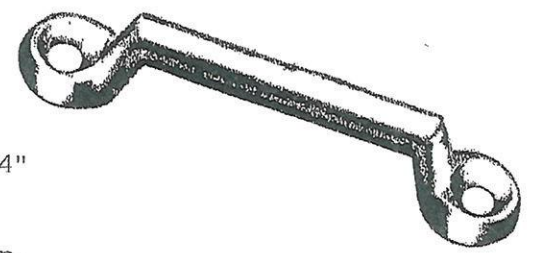

\$23

DOOR STRAP LOOPS

Part No. 108  
Overall length 3"  
For 1 1/4" strap  
Takes #12 screws  
Brass

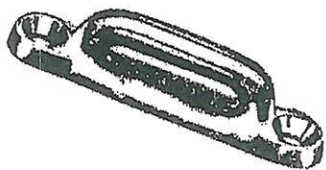

\$20

Part No. 107  
Overall length 3 1/4"  
For 1 1/2" strap  
Takes #12 screws  
Brass

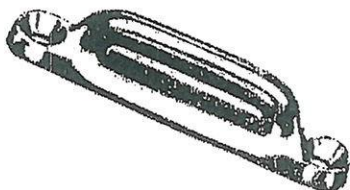

\$22

Part No. 175  
Overall length 2 7/8"  
For 1 1/4" strap  
Takes #10 screws  
Brass

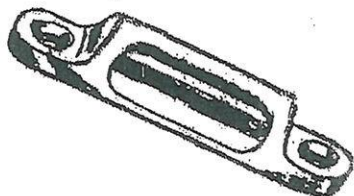

\$22

Part No. 121  
Overall length 4 1/2"  
For 2" strap  
Takes #12 screws  
Brass

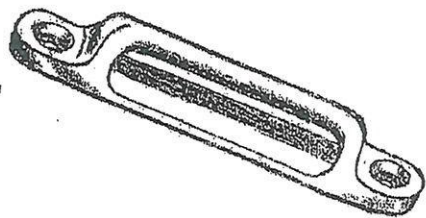

\$26

DOOR STRAP LINKS

Part No. 119  
For 1 1/4" strap  
Allows the door strap  
assembly to fold up flat  
against the body or door.  
Brass

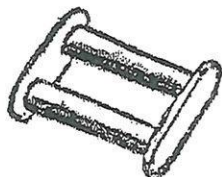

\$18

Part No. 118  
For 1 1/2" strap  
Strap lasts longer because  
it hinges, instead of  
bending.  
Brass

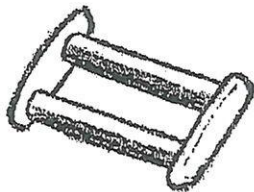

\$18

HARNESS LEATHER DOOR CHECK STRAPS

Beautifully hand stitched for strength and appearance. Black, saddle, or oiled chestnut brown color. Made to your dimensions on your loops or on ours (add cost of loops and \$6 per loop for polishing). There are fourteen different loops in our catalog suitable for door check straps.

STANDARD CHECK STRAP

Price is for leather & labor.

- 1" Wide @ \$28 Each
- 1 1/4" Wide @ \$32 Each
- 1 1/2" Wide @ \$36 Each
- 2" Wide @ \$40 Each

Send us your loops or add the cost of our loops and polishing. State length of check strap (center to center of loop mounting holes when door is in the open position). Mark leather color black, saddle, or oiled chestnut brown.

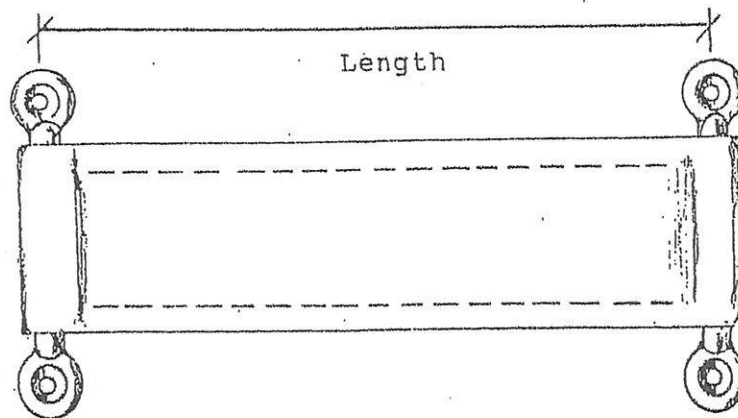

Note: Some automobile makers used a door strap link which allowed the door strap assembly to fold up flat against the body or door. This makes a neat, out-of-the-way appearance and the strap lasts longer because it isn't bent back and forth each time the door is opened and closed. The drawing on the next page illustrates how a door strap assembly looks with and without the door strap link.

13

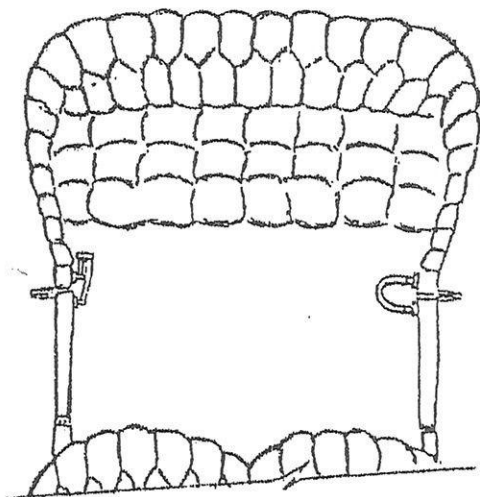

**DELUXE CHECK STRAP**

Price is for leather, labor, door strap link, and polishing door strap link.

1 1/4" Wide @ \$60 Each

1 1/2" Wide @ \$62 Each

Send your loops or add the cost of our loops and polishing. State length. Also need center to center of loop mounting holes when door is closed. Choose black, saddle, or oiled chestnut brown.

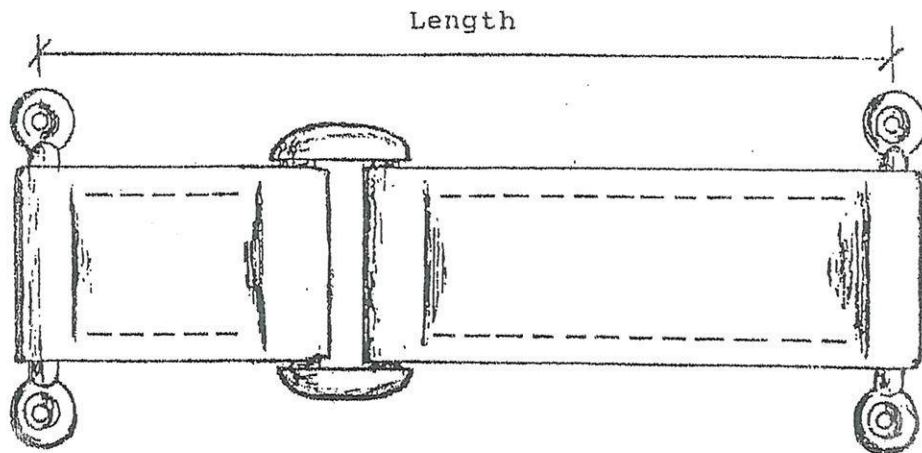

14

**ORDERING YOUR CRANK BOOT/STRAP**

On the order form, specify boot style and leather color (black, saddle, oiled brown). State buckle style and finish desired. Also state width of strap (5/8" or 3/4" are typical) and circle crank handle style. To make your crank boot/strap look like it belongs on your car, we need a few measurements. Please fill them in on the order form.

The crank strap usually goes around a bracket, around the frame, or through a loop. The "total distance" measurement allows us to make the strap the correct length so you won't have to cut it off. If your strap does go around something large (like the frame), add 2 or 3 inches to the "total distance" measurement.

**Crank Handle Styles:**



Cylindrical



Curved

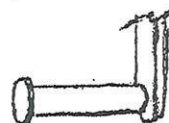

Cylindrical with ring

**CRANK BOOTS WITH STRAPS**

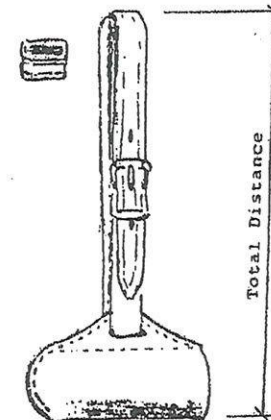

STYLE A  
Part No. 450  
Curved end

\$90

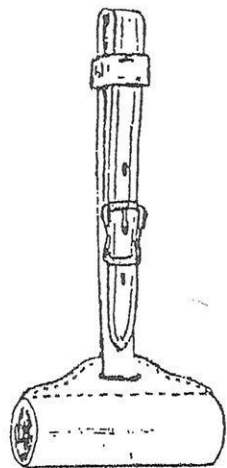

STYLE B  
Part No. 451  
Open both ends

\$80

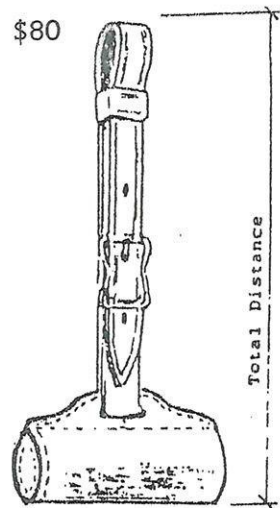

STYLE D  
Part No. 453  
End stitched in

\$100

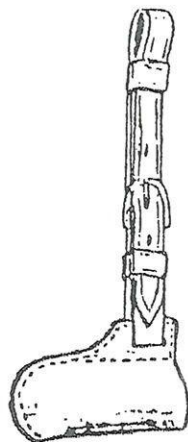

STYLE C  
Part No. 452  
Curved end with  
offset strap

\$90

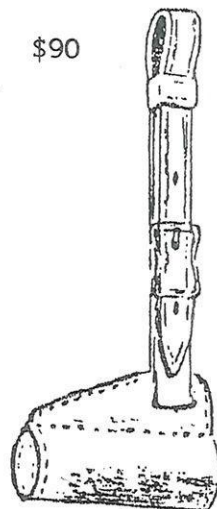

STYLE E  
Part No. 454  
End stitched in  
with offset strap

\$100

CRANK BOOT WITH STRAP ORDERING INFORMATION

Boot Style \_\_\_\_\_

Leather Color \_\_\_\_\_

Buckle Style \_\_\_\_\_

Buckle Finish \_\_\_\_\_

Strap Width \_\_\_\_\_

My crank handle style is \_\_\_\_\_

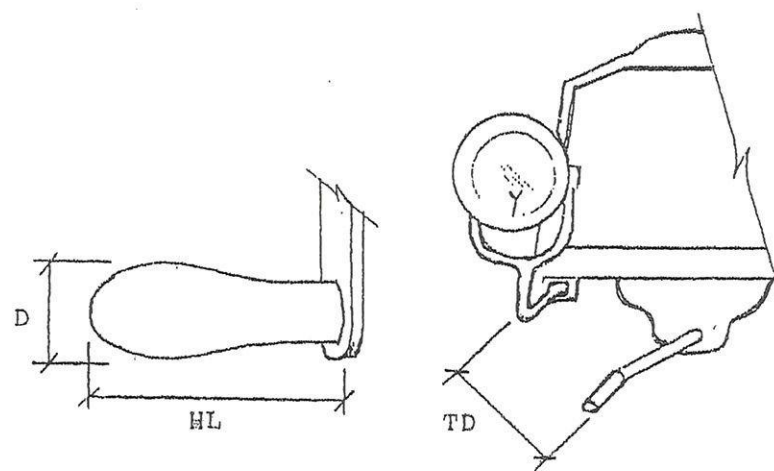

HL (Handle Length) \_\_\_\_\_

D (Diameter of largest part of handle) \_\_\_\_\_

TD (Total Distance) \_\_\_\_\_

To get the "Total Distance", measure from the bottom edge of the handle to the top edge of what the strap will go around with the crank handle positioned where you want it to be. If your strap does go around something large (like the frame), add 2 or 3 inches to the "total distance" measurement.



(17)

WIDE BOW REST BRACKET

Part No. 167  
Overall length 3"  
Slot for 7/8" strap  
5/8" hole, set screw.  
You drill & tap.  
Used on Marmon  
Special Order  
Brass Each

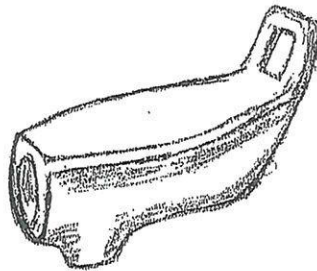

\$50

DOUBLE SADDLE BOW REST BRACKET

Part No. 280  
Early European Style  
Length 7 3/4"  
Brass sand casting  
You drill hole  
Pair

Part No. LC280  
Completely finished, black leather covered  
All hand stitched, polished brass  
Drilled 1/2" hole, right & left  
Greater support for top assembly  
Pair

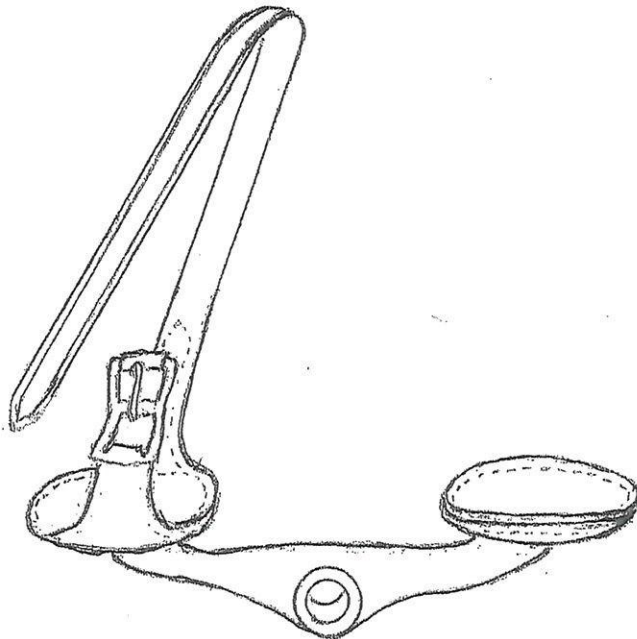

\$150

\$450

(18)

BOW REST BRACKET

Part No. 106  
Overall length 3 3/8"  
Slot for 3/4" strap  
1/2" Hole  
With set screw  
You drill & tap  
Brass  
Each

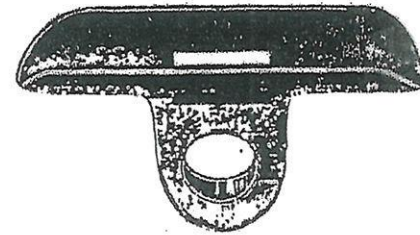

\$50

LEATHER COVERED BOW REST BRACKET

Part No. LC106  
Black, saddle or oiled  
brown leather.  
Polished brass or black painted.  
1/2" or 5/8", or 3/4" hole.  
Drilled/tapped with set screw.  
3/4" strap with your choice of  
buckle style.  
Hand stitched.  
Pair

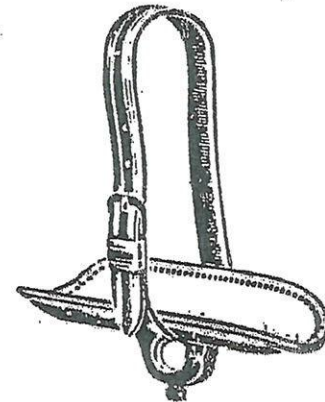

\$180

OFFSET LOOP BOW REST

Part No. 138  
Overall length 3 3/4"  
Slot for 7/8" strap  
5/8" hole  
With set screw  
You drill & tap  
Brass  
Each

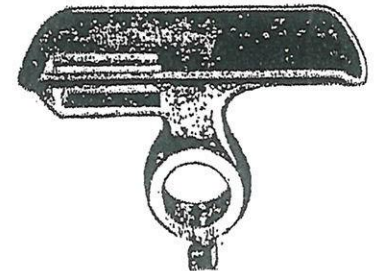

\$50

Part No. LC138  
Polished Brass  
Leather pad installed  
Two 7/8"x24" straps  
Drilled & tapped  
Black, saddle or oiled brown leather  
Pair

\$160

EMCO BOW REST

(19)

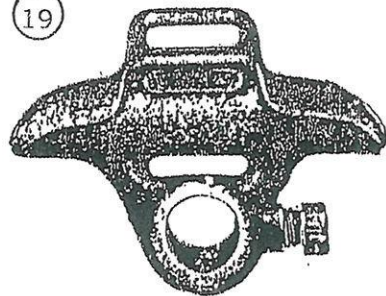

Part No. 139.  
Overall length 3 3/4"  
Slot for 3/4" strap  
5/8" hole  
With set screw  
You drill & tap  
Brass  
Each

\$60

EMCO BOW REST PADS & STRAPS

Part No. L139  
Black, saddle or oiled  
chestnut brown leather.  
Your choice of buckles.  
Two pads & two straps.  
Hand stitched  
Set



\$42

EMCO BOW RESTS COMPLETE

Part No. 139POL  
Polished Brass, drilled & tapped, pads & straps  
included, black, saddle, or oiled brown leather  
Pair

\$225

EARLY BOW REST BRACKET

Part No. 162  
Height 3"  
Slot for 3/4" strap  
Recessed for leather pad.  
3/4" hole, set screw.  
Can sleeve to 5/8".  
You drill & tap.  
Brass  
Each

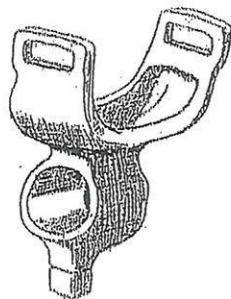

\$50

EARLY BOW REST BRACKET COMPLETE

Part No. 162POL  
Polished Brass, drilled & tapped, pads & straps  
included, black, saddle, or oiled brown leather  
Pair

\$200

HOOVER BOW REST

(20)

Part No. 135  
Overall length 3 3/8"  
Buckle cast into bracket  
5/8" hole  
With set screw  
You drill & tap.  
When adjusted, four sharp  
edges and the set screw  
grip securely on the bow  
arm, preventing it from  
working loose.  
Pads & 3/4" straps  
included with rivets.  
Black, saddle, or  
oiled chestnut brown.  
Brass  
Pair

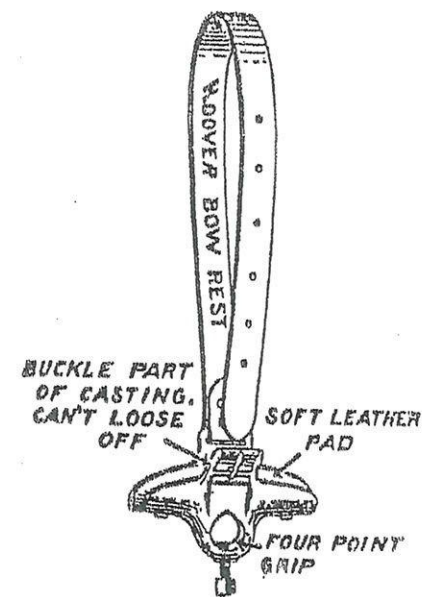

\$130

Part No. 135POL  
Polished, tapped & assembled  
Pair

\$180

GOLDE-TYPE TOP HOLDER

Part No. 125  
Bronze castings  
Steel rod  
5/8" hole with set screw.  
Attaches to your bow arm.  
Early style wing nut.  
Black leather pad riveted  
to lower saddle.  
Black Powder painted.  
Completely assembled.  
A superior top holder  
that was available to  
early auto body builders  
and auto supply outlets.  
Pair (right & left)



\$200

21

BUICK TOURING 28-31 BOW REST

Part No. 126  
Overall length 4 1/4"  
Width 2 3/8"  
Two slots for 3/4" strap  
1/2" Hole  
Brass  
Pair



\$200

TOP BOW RETAINING PINS WITH STRAPS

Part No. 410  
Brass 5/32" cotter pin, 7/16" wide strap, Black,  
Saddle or Oiled Chestnut Brown color.  
Dimension X will be 5" or your dimension.  
Pair

\$15

Part No. S410  
Same as above except Stainless Steel cotter pin.  
Pair

\$15

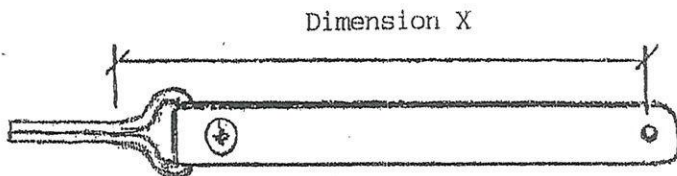

22

1912 CADILLAC TOP HOLD DOWN ASSEMBLY

Part No. 502  
May fit other years. Brass & Bronze castings.  
Steel rods. Upper & Lower Saddles have leather  
pads. Uses a tall wing nut with a locking wing  
nut. Lower saddle has a 3/4" hole and a set  
screw. Upper saddle has a spring so it remains  
adjustable. Bolts into a 5/8" hole.  
Painted Black and completely assembled.

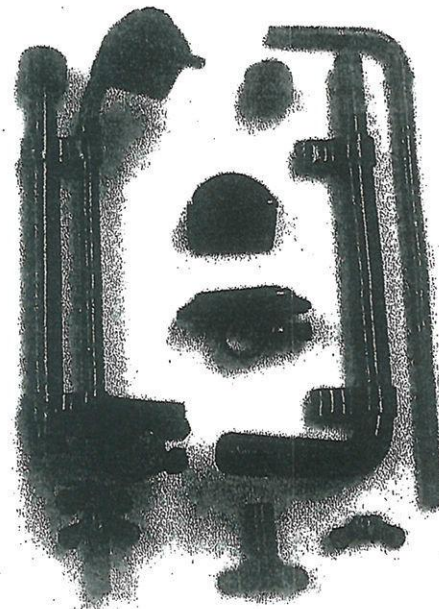

Pair

\$750

CADILLAC LOWER SADDLE

Part No. 503  
Bronze casting  
3/4" hole  
Leather pad  
Painted Black  
Pair



\$100

BLADE BOW SEPARATOR

Part No. 114  
Overall length 2"  
Alligns bows in down position  
Takes #6 screws  
Brass  
Set (one male, one female)

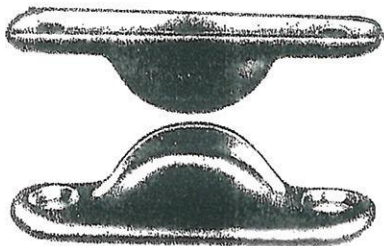

\$30.

4-SCREW BOW SEPARATOR

Part No. 115  
Overall length 1 1/2"  
Alligns bows in down position  
Takes #6 screws  
Polished  
Brass  
Set (one male, one female)

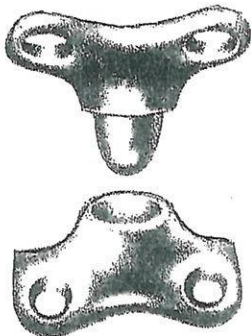

\$30

WIDE BOW SEPARATOR

Part No. 116  
Overall length 2"  
Width 3/4"  
Alligns bows in down position  
Takes #6 screws  
Brass  
Set (one male, one female)



\$30

IROQUOIS BOW SEPARATOR SET

Part No. 192  
The Iroquois Auto Top Co in Utica, N.Y. used these bow separators on tops they built that were fitted to cars such as Stanley around 1908. Style A went on the front bow, Style B on the back bow, and Styles C and D went on the center bows. All styles held on with brass machine screws. Separators are tapped for 10-24 flat head brass screws which are included. Lost wax castings. Brass

One set includes:

- Style A 2
- Style B 2
- Style C 4
- Style D 4
- Screws 8

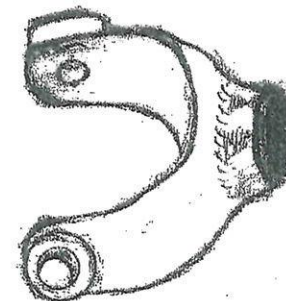

Style A

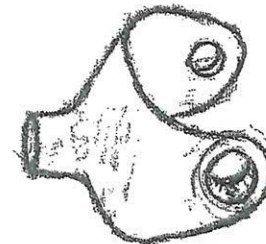

Style B



Style C



Style D

Complete Set 4-Bow Top

\$300

(25)

SHORT TOP TO WINDSHIELD BRACKET

Part No. 147  
Bronze castings  
Overall length 3 1/8"  
5/8" center of hole to bow  
3/8" threaded thumb screw  
5/8" hole  
Each

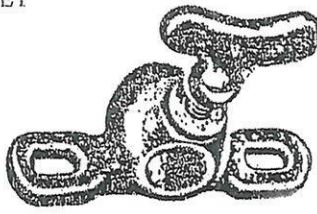

\$50

TALL TOP TO WINDSHIELD BRACKET

Part No. 149  
Cast iron NOS  
Black  
Overall length 3 1/4"  
1 1/2" center of hole to bow  
3/8" threaded thumb screw  
5/8" hole  
Each



\$50

FLAT THUMB SCREW BLANK

Part No. 148  
Bronze casting  
You thread up to 3/8"  
Width is 2"  
Part for threading is 7/8"  
Each



\$18

S-THUMB SCREW BLANK

Part No. 145  
Bronze casting  
You thread up to 5/16"  
Width is 1 1/2"  
Part for threading is 1 1/8"  
Each



\$18

(26)

WS ROD LOWER SUPPORT BRACKET

Part No. 218  
Overall length 1 7/16"  
3/8" Hole  
3/16" thick tongue  
Can use with No. 163  
Variable mounting bracket  
Brass  
Each

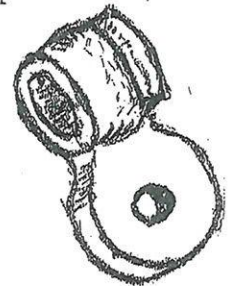

\$18

WS ROD UPPER SUPPORT BRACKET

Part No. 219  
Overall Length 1 3/4"  
Width 7/8"  
Large opening 1/2"-  
Hole 3/8"  
Boss for set screw  
Brass  
Each

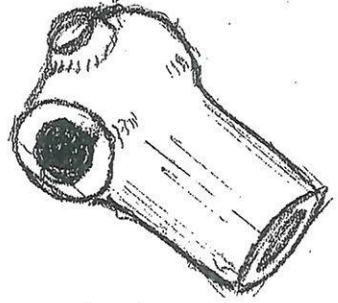

\$22

PROP NUT KEEPERS

Part No. 314  
Tabs bend on sides of  
prop nut to keep it  
secure.  
7/16" size  
Stainless Steel  
Each

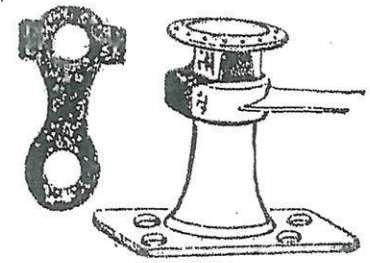

\$15

PROP NUT KEEPER

Part No. 315  
1/2" size  
Steel  
NOS  
Each



\$15

SMALL BRASS BEADED PROP NUT

27

Part No. 301  
1 1/8" Diameter  
7/16" Thread  
Square nut  
Cast Brass  
Polished  
Each



\$60

BRASS BEADED PROP NUT

Part No. 302  
1 1/4" Diameter  
7/16" Thread  
Square nut  
Cast Brass  
Polished  
Each

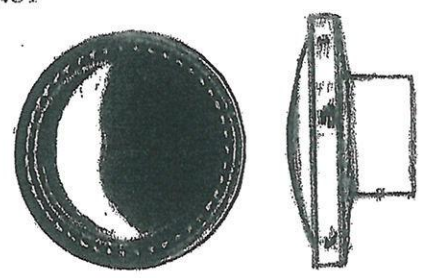

\$60

SMALL TOP PROP NUT

Part No. 303  
Painted Black  
Square nut  
1 1/4" diameter  
7/16" thread  
Brass  
Each



\$15

LEATHER COVERED, HAND STITCHED TOP PROP NUT

Part No. 311  
1 3/4" Diameter  
7/16" Thread  
Black leather  
Black square  
Brass  
Each



\$65

STRAP RAIL WITH BRASS HANDLES

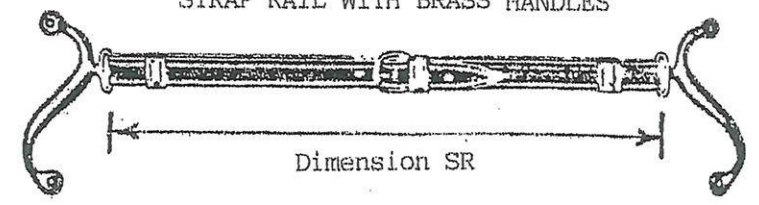

BRASS "S" HANDLES

Part No. 136  
Loops for 1" strap  
Unpolished  
Pair

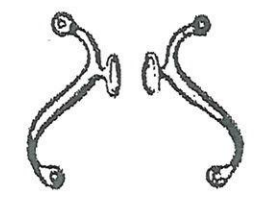

\$100

Part No. 136P  
Polished  
Pair

\$190

FLAT LEATHER STRAP RAIL

Part No. 460  
Width 1"  
Black, Saddle or Oiled Brown leather  
With leather loops  
Holes not punched in strap unless requested.  
State your choice of buckle  
Each

\$65

ROUND LEATHER STRAP RAIL

Part No. 461  
Width on ends 1"  
7/16" round leather  
Black, Saddle or Oiled Brown leather  
Hand stitched onto your handles  
State "Dimension SR"  
Each

\$120

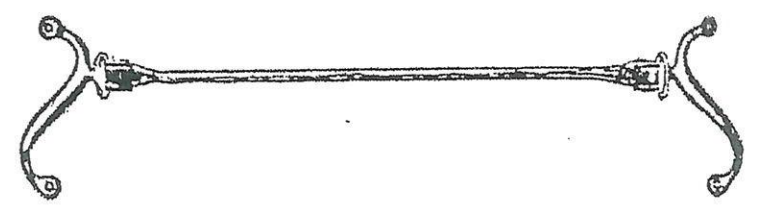

29

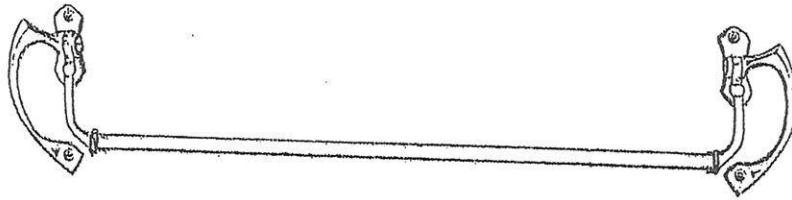

DELUXE FOLDING ROBE RAIL ENDS

Part No. 170  
Four lost-wax castings  
and two screws.  
You drill, tap and fit.  
Brass 5/8" tube needed  
to complete.  
Has right and left grab  
handles to assist when  
entering or exiting car.  
Brass 6-piece kit

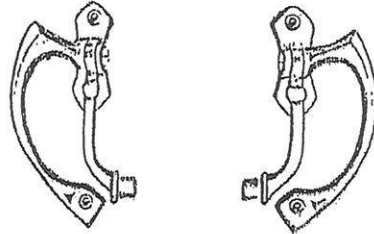

\$125

ROBE RAIL TUBE

Part No. 171  
5/8" Brass tube  
36" Length  
Each

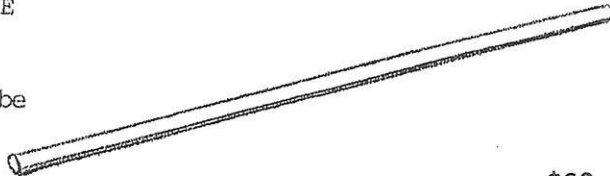

\$60

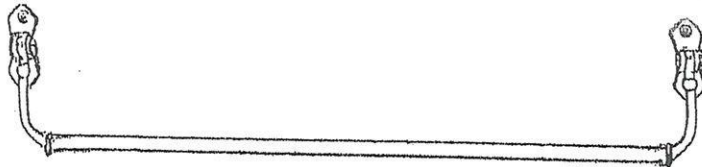

FOLDING ROBE RAIL

Part No. 172  
Four lost-wax castings  
and two screws.  
You drill, tap and fit.  
Brass 5/8" tube needed  
to complete.  
Brass 6-piece kit



\$100

30

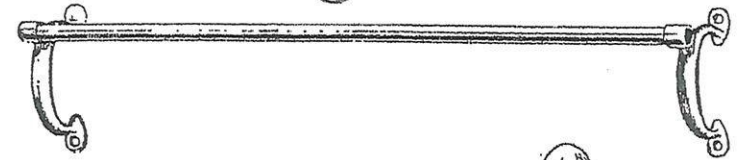

"C" TYPE ROBE RAIL ENDS

Part No. 232  
Nice brass sand castings  
You drill & fit.  
Longest dimension 6 1/2".  
5/8" brass rod needed  
to complete assembly.  
Right & left  
Pair

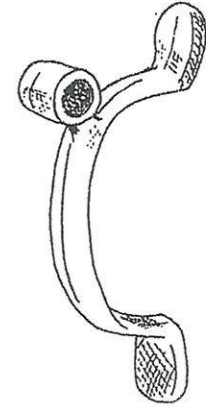

\$120

"S" TYPE ROBE RAIL ENDS

Part No. 230  
Nice brass sand castings  
You drill & fit to 5/8"  
brass rod.  
Height is 5 1/2".  
Right & left  
Pair

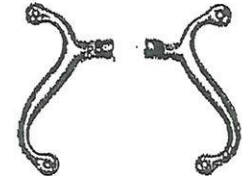

\$25

BODY GRAB HANDLE

Part No. 284  
Longest dimension 4 3/4"  
Height 1 7/8"  
Mounts to body or pillar  
Brass  
Each



\$65

31

## CURVED INSIDE HANDLE

Part No. 345  
 Overall length 4"  
 Square hole 5/16"  
 Used by Franklin  
 in the 1920s and  
 possibly others  
 Brass  
 Each

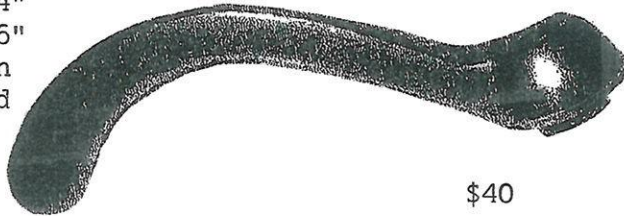

\$40

## INSIDE HANDLE

Part No. 178  
 Overall length 4 3/16"  
 Square hole 3/8"  
 Brass  
 Each

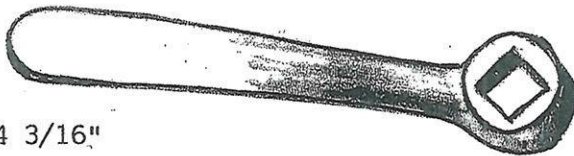

\$25

## TOP CLAMP HANDLE

Part No. 343  
 Overall length 5 1/4"  
 Overcenter handle used  
 with top clamps made by  
 Bair for many makes.  
 End will need to be  
 shaped around the  
 heavy spring. This  
 part can be used to  
 replace a broken or  
 missing handle.  
 This type of top clamp  
 was used about 1910 and  
 into the teens.  
 Bronze  
 Each



\$40

32

## LARGE FOOT REST BRACKETS

Part No. 264  
 Overall length 8"  
 Machined for 1" tube  
 Center to center of pivot  
 point to tube is 6 1/2".  
 Drilled for 5/16" screw.  
 Nice brass sand castings.  
 Pair

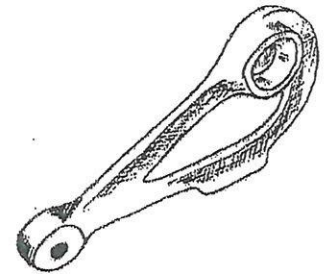

\$120

## L &amp; M FOOT REST MOUNTING BRACKET

Part No. 164  
 Overall length 2 1/16"  
 Width 7/8"  
 Tapped for 5/16-18 brass,  
 countersunk, oval-head,  
 slotted screw, included.  
 Fits Large & Medium Foot Rest  
 Mounting Brackets.  
 Brass  
 Each

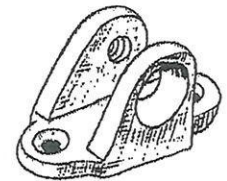

\$24

## MEDIUM FOOT REST BRACKETS

Part No. 268  
 Overall length 7"  
 Machined for 1" tube  
 Center to center of pivot  
 point to tube is 5 5/8".  
 You drill for rivet or  
 screw.  
 Nice brass sand castings.  
 Pair

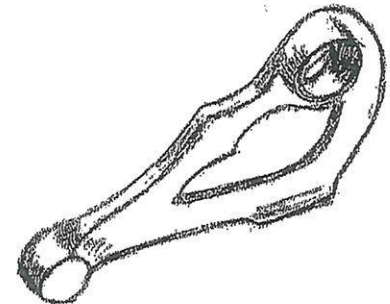

\$110



M & S FOOT REST MOUNTING BRACKET

Part No. 168  
Overall length 2 1/4"  
Width 3/4"  
Holes for 1/4" rivet included,  
or use Clevis pin.  
For Medium & Small Foot Rest  
Brackets.  
Brass

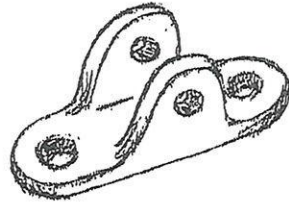

\$22

SMALL FOOT REST BRACKETS

Part No. 263  
Overall length 6 1/8"  
Machined for 1" tube  
Center to center of pivot  
point to tube is 4 3/4".  
You drill for rivet or  
screw.  
Nice brass sand castings.  
Pair

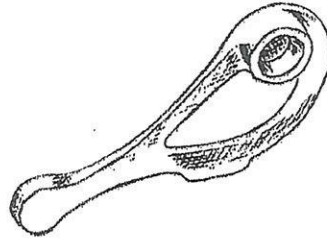

\$95

VARIABLE FOOT REST MOUNTING BRACKET

Part No. 163  
Overall length 2 1/16"  
Width 9/16"  
You drill for proper height  
of pivot point.  
Made for Small Footrest Bracket  
but has various uses.  
Brass  
Each

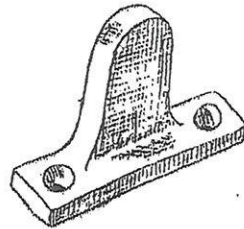

\$18

FOOT REST TUBE

Part No. 260  
1" seamless brass tubing  
Wall thickness .065  
Length 30" or specify if  
needed longer or shorter.  
Each



\$65

UNIVERSAL TIRE HOLDER

Part No. 270  
Longest dimension 5 5/8"  
You machine slots for 1"  
strap.  
Has 9/16" hole that  
you machine for 5/8"  
or 3/4" rod.  
Add two set screws  
to secure on rod.  
Brass sand casting.  
Each

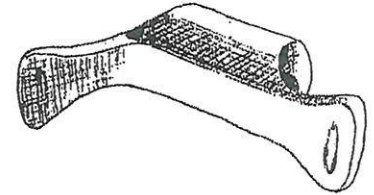

\$55

LOWER TIRE HOLDER

Part No. 271  
Longest dimension 6 1/8"  
You machine for 1" strap.  
Drill holes and mount on  
your running board.  
Brass sand casting  
Each



\$55

FLANGE MOUNT TIRE HOLDER

Part No. 272  
Brass sand casting  
You machine slots for 1" or smaller straps and drill  
holes for mounting.

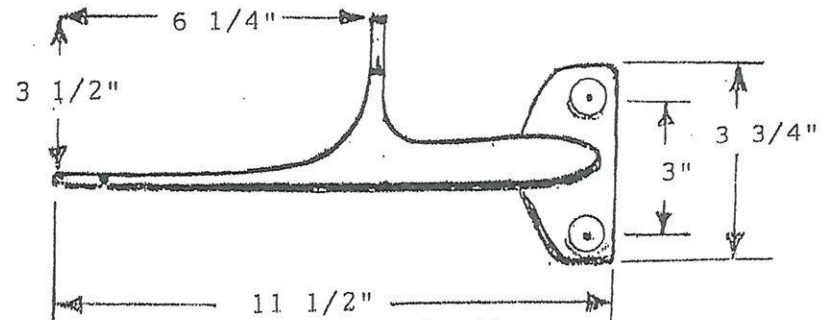

Each

\$100

OFFSET TIRE ARM

Part No. 273  
 Brass sand casting  
 Use Tire Arm Socket (No. 174) to mount.  
 Has support pad on arm if needed.  
 You machine slots for 1" or smaller straps.  
 Can be cut and welded to different dimensions.

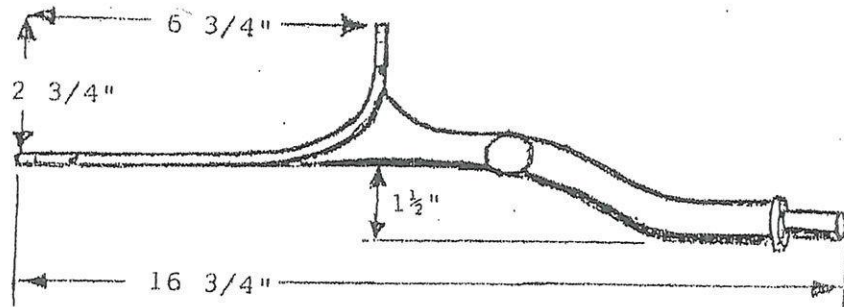

Each

\$100

STRAIGHT TIRE ARM

Part No. 274  
 Brass sand casting  
 Use Tire Arm Socket (No. 174) to mount.  
 You machine slots for 1" or smaller straps.

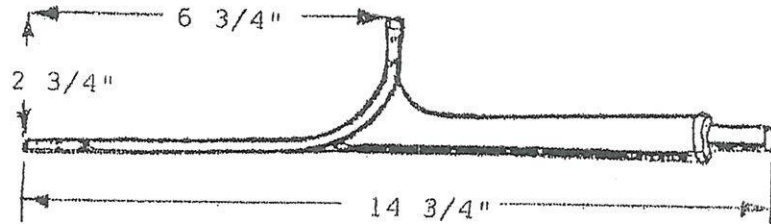

Each

\$95

TIRE ARM SOCKET

Part No. 174  
 Base is 2 1/2" x 1 1/2" x 1/4"  
 Holes for #12 screws.  
 You drill & tap for  
 set screw included.  
 Brass

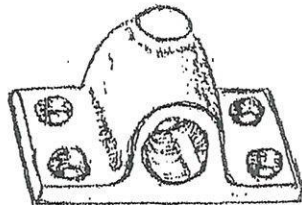

\$30

TRIGGER SNAP

Part No. 401  
 Overall length 2 3/8"  
 For 1" strap  
 Solid Brass, Each

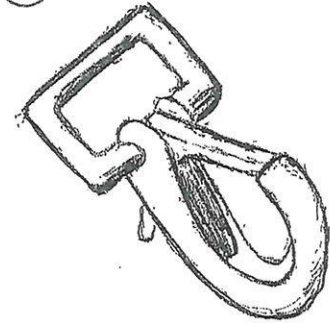

\$4

Part No. 401SS  
 Stainless Steel, Each

\$7

HEAVY DUTY BOLT SNAP

Part No. 402  
 Overall length 3"  
 For 1" strap  
 Swivel loop  
 Solid Brass, Each

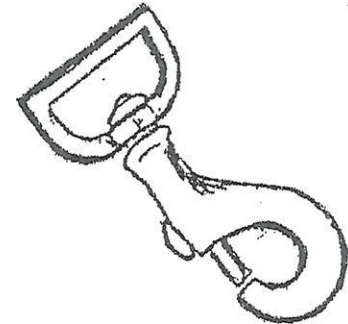

\$4

Part No. 402SS  
 Stainless Steel, Each

\$7

HEAVY DUTY SPRING SNAP

Part No. 403  
 Overall length 3"  
 For 1" strap  
 Fixed loop  
 Brass with SS spring, Each

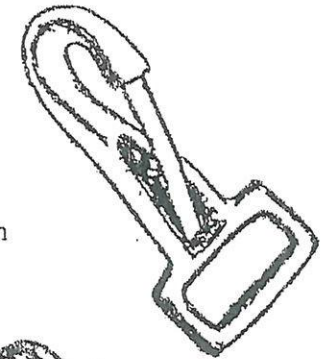

\$4

Part No. 403SS  
 Stainless Steel, Each

\$7

SPRING SNAP

Part No. 404  
 Overall length 3"  
 For 1" strap  
 Nickel plated iron  
 Each

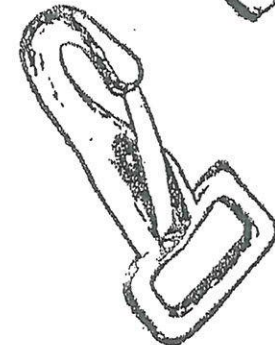

\$4

GAS KEY & BOTTLE OPENER

(37)

Part No. 213  
 Key for your Prest-o-lite  
 bottle or gas tank  
 Bottle opener  
 Perfection on key  
 Used in early tool kits  
 Bronze  
 Each

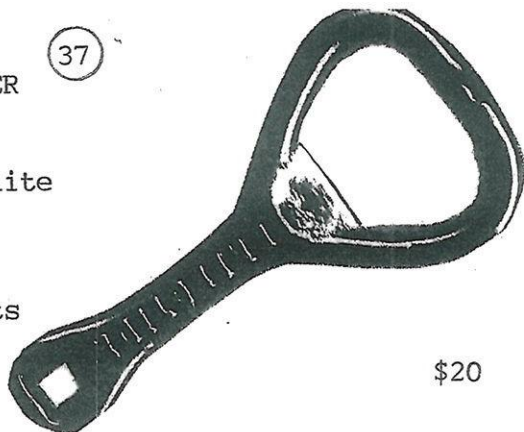

\$20

TIGHTENING BUCKLE

Part No. 165  
 For 1" strap.  
 Buckle the strap  
 while the buckle  
 is in its open  
 position, then  
 close the buckle  
 (as illustrated)  
 to draw the  
 strap up tight.  
 Polished brass  
 Each

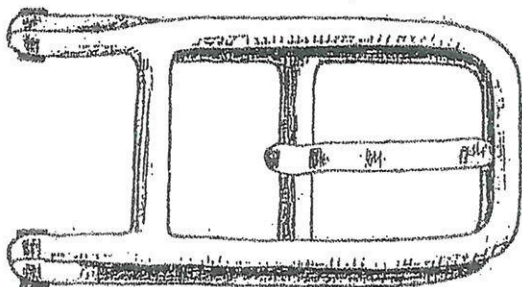

\$90

Part No. 165K  
 Two castings, two rivets, one tongue.  
 Drilled and countersunk for rivets.  
 You polish and assemble.  
 Each kit

\$60

FORD HOOK BUCKLE

Part No. 129  
 For 1" strap.  
 For '09 to '22 Ford front top  
 stay straps that connect to  
 frame bracket or windshield.  
 Silicon bronze  
 Polished  
 Each

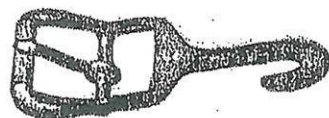

\$35

Part No. 129SS  
 Stainless Steel For 7/8" strap  
 Each

\$15

(38)

ROUND LEATHER FRONT TOP STAY STRAPS

Over the years, many cars have had their weathered or broken round top stay straps replaced by easier to obtain flat straps. If this has happened to your car, now you have the opportunity to change them back to the round style again.

Top stay straps have been made in many styles. . . some better than others. We can make most any style that you require. A less desirable design is one which puts all the tension on the hole in the leather that the buckle tongue goes through. Like this:



Better designs take the pressure off of the hole in the leather and offer mechanical advantage (as in pulley systems) when tightening. Styles, sizes, and combinations of top hardware are endless. We can copy any design or style that you need. Following are six styles that can be ordered. They come standard with footman loops #102 or #113 at the top, and either #402 bolt snaps or #403 spring snaps at the bottom. These will be polished brass and cleared. The 150 center bar roller buckle is standard and also polished & cleared. Other buckles, hardware, or finishes on request. The #101 Disconnect Link with footman loop can be used for an additional \$40 on Styles A, B, E, and F. For Styles C and D an additional \$80 is needed. The more accurate your Total Length dimension, the better the straps will fit and look. Below are the older style buckles that are available.

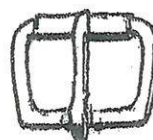

50 Buckles

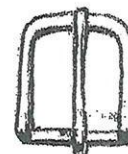

12 Buckles

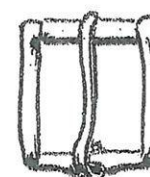

49 Buckles

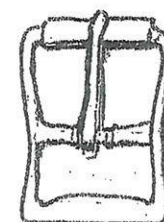

150 Buckles

(39)

ROUND LEATHER FRONT TOP STAY STRAPS

STYLE A

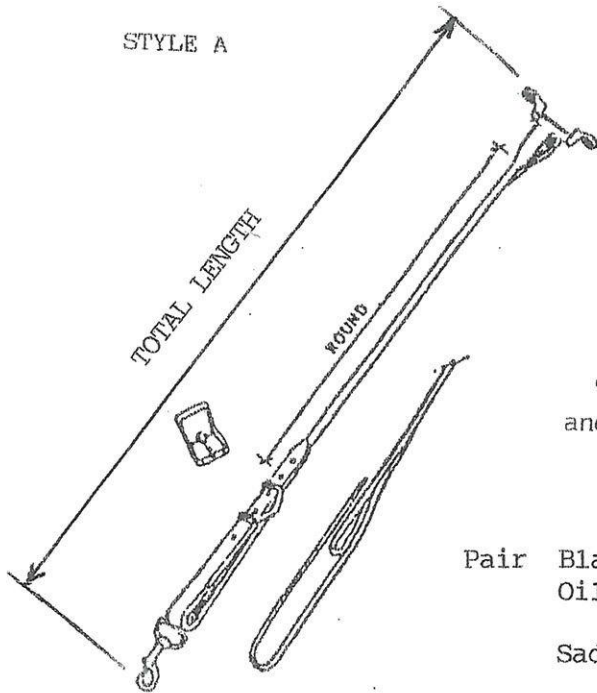

The strap is 1" wide and the round is 7/16".

Pair	Black or Oiled Brown	\$260
	Saddle	\$280

STYLE B

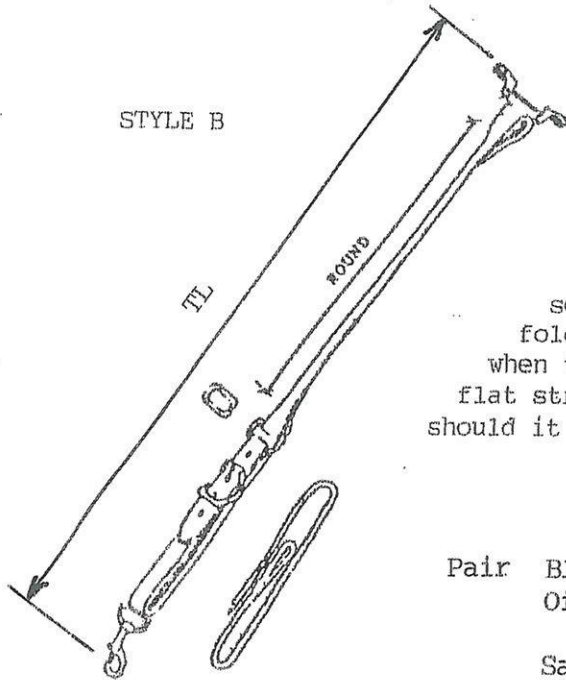

This style uses a brass square link. The strap folds easily for storage when the top is down and the flat strap is simple to replace should it become worn in the future

Pair	Black or Oiled Brown	\$260
	Saddle	\$280

(40)

"Y" ROUND LEATHER FRONT TOP STAY STRAPS

STYLE C

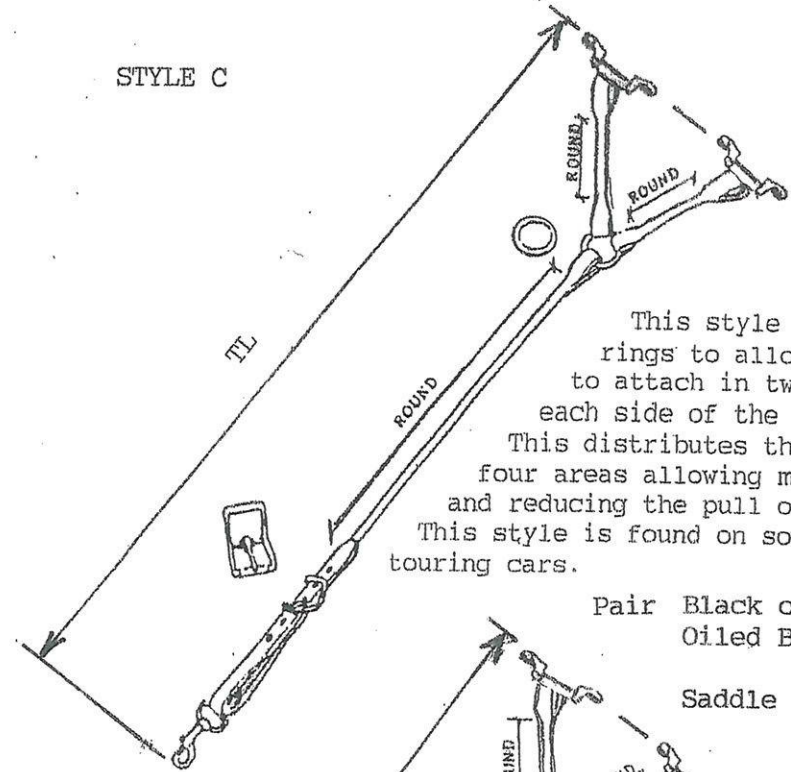

This style uses brass rings to allow the straps to attach in two places on each side of the top bow. This distributes the pull to four areas allowing more stability and reducing the pull on the loops. This style is found on some large touring cars.

Pair	Black or Oiled Brown	\$400
	Saddle	\$420

STYLE D

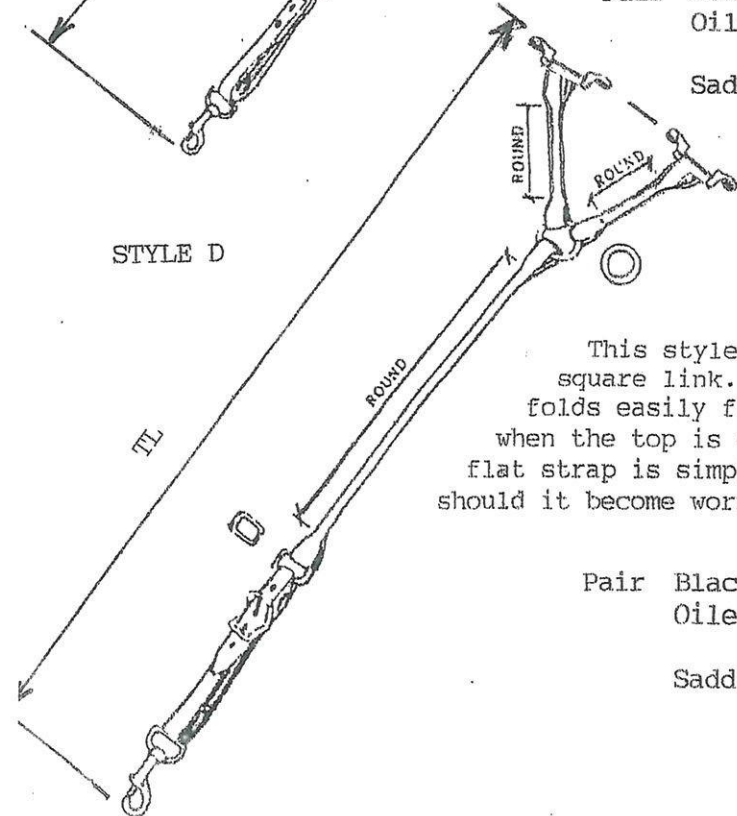

This style uses a brass square link. The strap folds easily for storage when the top is down and the flat strap is simple to replace should it become worn in the future.

Pair	Black or Oiled Brown	\$400
	Saddle	\$420

41

FLAT FRONT TOP STAY STRAPS

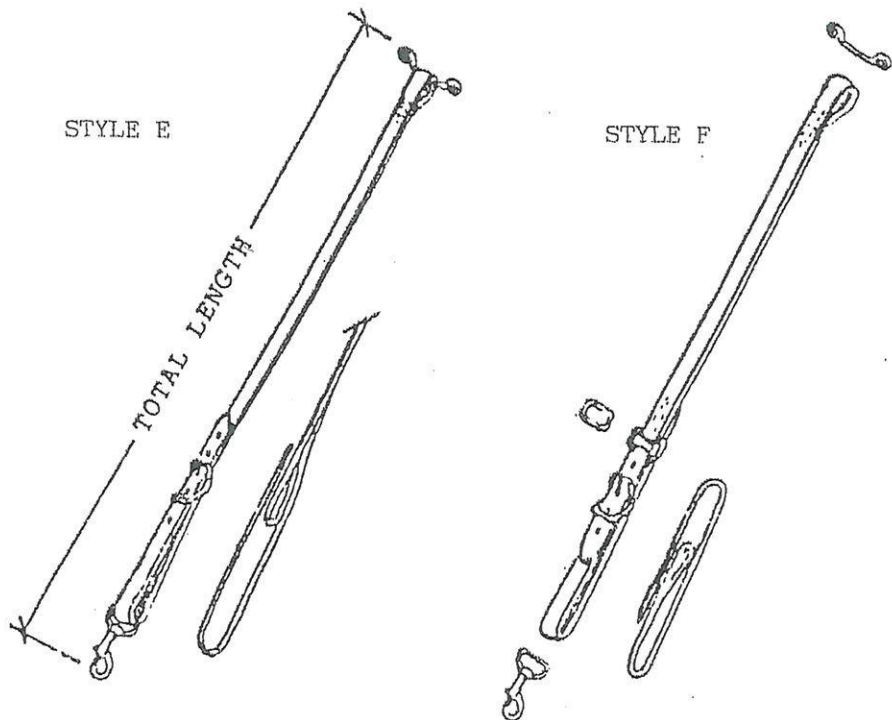

Black, Saddle, or Oiled Chestnut Brown Leather.  
 Beautifully hand stitched.  
 1" wide leather straps.  
 Brass Center-bar roller buckles.  
 Brass square links on Style F.  
 Upper attachment: #102 or #113 polished.  
 Lower attachment: #402 Bolt Snap  
 Other combinations of hardware available.  
 Give Total Length of strap assembly (from bow to point Bolt Snap will attach).

To order Flat Straps above:

State Style E or Style F  
 State Total Length  
 State Black or Saddle or Oiled Chestnut Brn.

Pair	Black or Oiled Chestnut Brown	\$160
	Saddle	\$180

42

BACK STAY STRAP STYLES

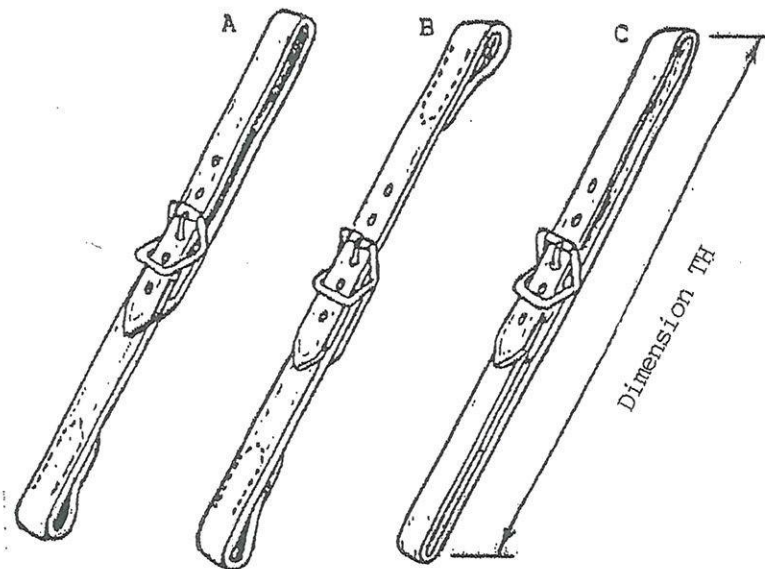

TH = \_\_\_\_\_ Total Height on strap assemblies.  
 NOTE: If you punch holes in straps then TH Dimension is not extremely critical. It is usually best to fit straps and then punch holes. If you want holes already punched in straps, then a simple drawing showing mounting points on bow and body with dimension would be helpful.

COMPLETELY FINISHED ASSEMBLIES (hand stitched)  
 Using your upper/lower attachments:

1" Wide	Pair \$90
1½" Wide	Pair \$100

COMPLETELY FINISHED ASSEMBLIES (hand stitched)  
 Using our upper/lower attachments:

List and add the cost of the attachments needed plus \$6 each for dressing, polishing, and clearing

Prices are for Black or Oiled Chestnut Brown.  
 Saddle color add \$10

CURTAIN ROLL-UP STRAPS

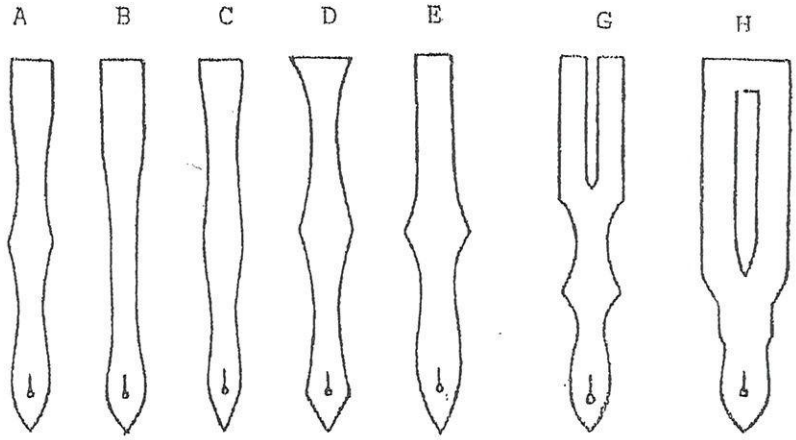

STYLES A, B, C, D, E

Part No. 420

Pair

\$32

STYLES G, H

Part No. 422

Pair

\$36

Black, Saddle, or Oiled Brown Chestnut color leather. Holds rolled up rear window curtain to back bow. State style and length (usually 10 to 12 inches).

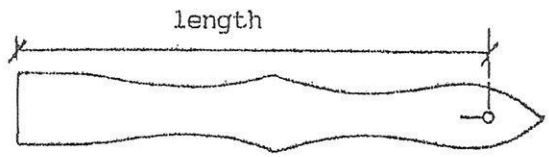

CARRIAGE KNOB

Part No. 421

For curtain roll-up straps.

New

Each



\$2

LEATHER STRAPS MADE TO ORDER

We can make back stay straps, hood hold down straps, spare tire securing straps, luggage rack straps, trunk straps, or any other straps that you need. Please send accurate description of what you need (width of strap, style and finish of buckle or hardware, black, saddle, or oiled chestnut brown leather, length dimensions) and I'll send you a price quote.

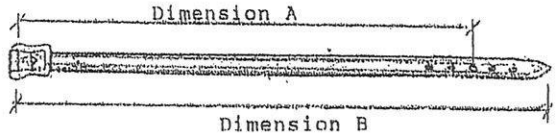

Above is an example of length dimensions. Dimension A shows where you plan to position the buckle on the strap. If you prefer to fit the strap and punch the holes yourself, then Dimension B is all we need. Holes in straps are placed about one inch apart. Straps are glued and beautifully hand stitched around buckles and loops.

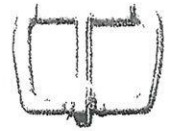

50 Buckles



12 Buckles

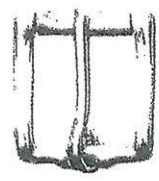

49 Buckles

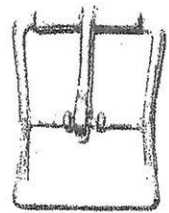

150 Buckles

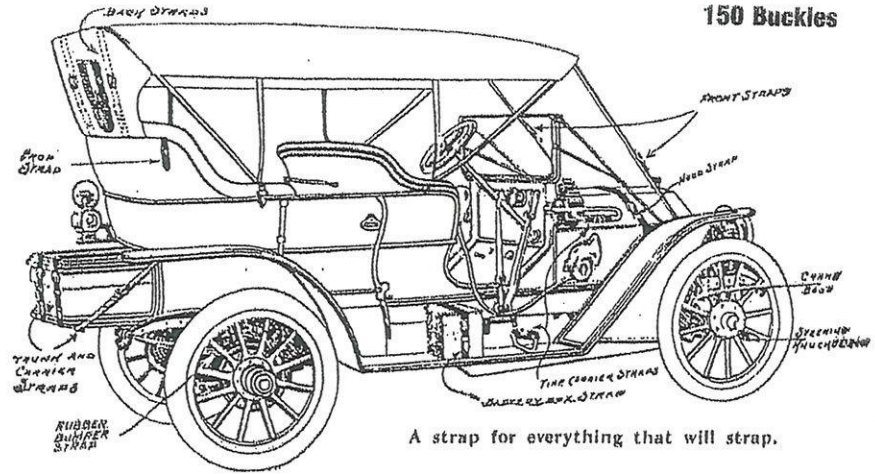

AUTO STRAPS

FOR TIRE CARRIERS, BOW RESTS, TRUNKS, MIRRORS, ETC.

Hand stitched, heavy leather straps with your choice of buckles. We keep a large selection of brass buckles in stock. We also have nickel, black powder painted, and chrome buckles. Decide the Total Length (Dim. B) that the strap needs to be. When I install straps, I prefer to fit the straps to the car and then punch the holes. I won't punch holes unless you request me to and you give me Dimension A which should be at least 4 inches shorter than Dimension B. Look on the chart to find the cost of BLACK or OILED CHESTNUT BROWN straps. If you want SADDLE color, add \$5 per strap and allow a little more time for me to make them. To order, state: WIDTH, LENGTH, BUCKLE STYLE & FINISH, LEATHER COLOR, and if you want holes punched, DIM. A.

PRICES ARE FOR BLACK & OILED CHESTNUT BROWN STRAPS

5/8" & 3/4" WIDTH	1 1/8" & 1 1/4" WIDTH
up to 24" = \$20	up to 30" = \$29
25" to 30" = \$22	31" to 36" = \$32
31" to 36" = \$24	37" to 42" = \$35
37" to 42" = \$26	43" to 48" = \$38
43" to 48" = \$28	49" to 54" = \$41
49" to 54" = \$30	55" to 60" = \$44
7/8" & 1" WIDTH	1 1/2" WIDTH
up to 24" = \$22	up to 30" = \$35
25" to 30" = \$24	31" to 36" = \$38
31" to 36" = \$26	37" to 42" = \$41
37" to 42" = \$28	43" to 48" = \$44
43" to 48" = \$30	49" to 54" = \$47
49" to 54" = \$32	55" to 60" = \$50

FOR SADDLE COLOR, ADD \$5 PER STRAP

Below are five styles 1 1/2" wide. Prices are for Black or Oiled Brown Leather sewn onto your loops. Saddle color add \$20. All hand sewn with leather pads under buckles. Price includes leather, labor, SS springs where shown, and polished & cleared Brass Buckles. Black, Stainless Steel and Chrome buckles also available. Check nickel buckle availability and price (sent out special). We will sew on your loops, or add the cost of ours (brass castings add \$5 each for polishing & clearing).

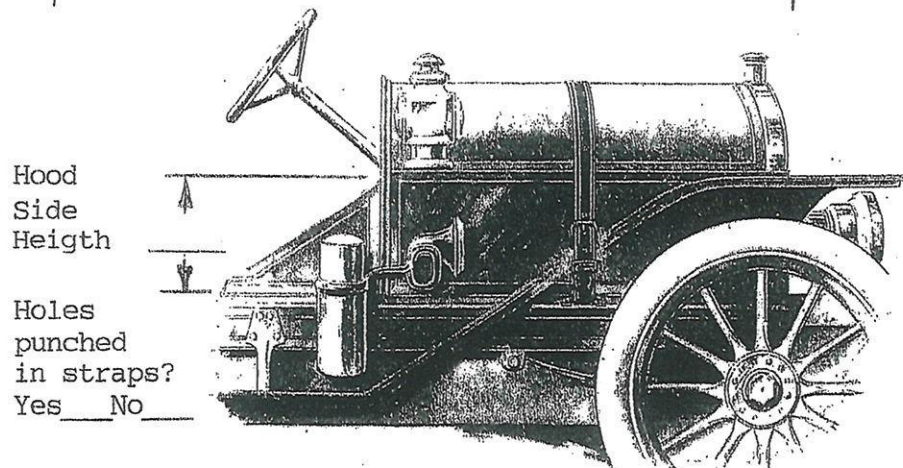
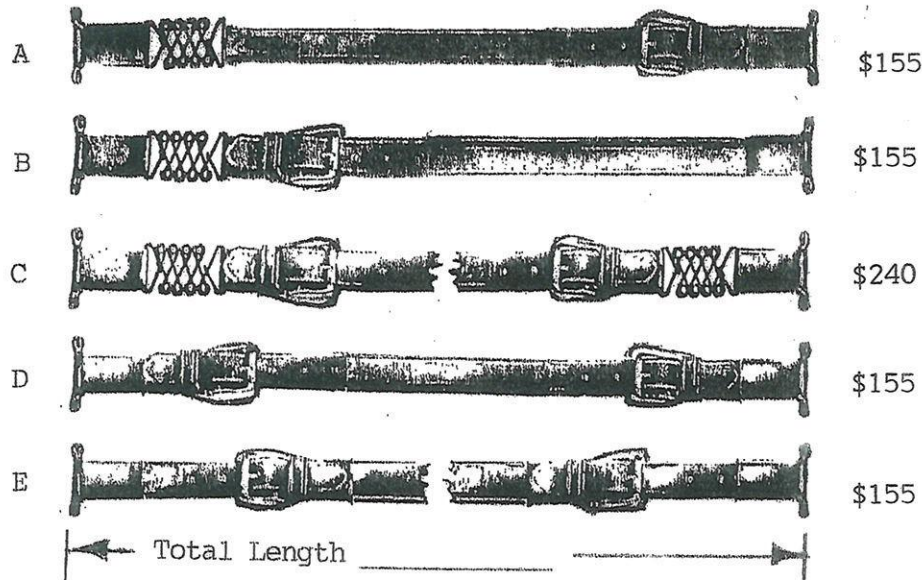

A car with a hood strap over the hood conveys the impression of greater horse-power and strength than does one without.

47

SPEEDOMETER SHAFT BRACKET

Part No. 155  
Overall length 2 5/16"  
7/8" hole  
Use where speedo  
shaft goes through  
floorboard, side  
apron or fender.  
Solid Brass  
Each

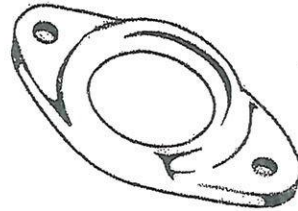

\$18

SPEEDOMETER SHAFT STRAP

Part No. 455  
Overall length 3"  
1" hole  
3/4" wide strap  
Eliminates sagging of  
the speedometer shaft.  
Prevents marring or  
scratching.  
All black  
Each

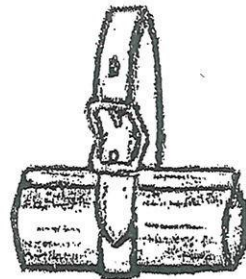

\$45

LUGGAGE RACK BRACKET

Part No. 151  
Length 2 1/2"  
Width 1"  
Height 1 1/4"  
Between blades 7/16"  
Brass

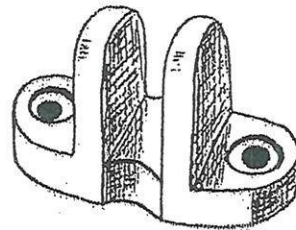

\$27

BRASS WING NUT

Part No. 128  
Width 1 5/8", height 7/8"  
Base 3/4" diameter.  
You drill & tap to 7/16" maximum.  
Each



\$17

48

MURPHY-TYPE FASTENERS

SINGLE STUD  
Part no. 413  
Cast Brass  
Polished  
Each

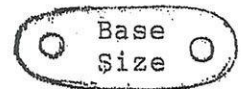

\$14.50

DOUBLE STUD  
Part No. 414  
Cast Brass  
Polished  
Each

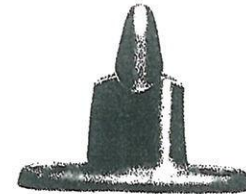

\$15.00

TRIPLE STUD  
Part No. 407  
Cast Brass  
Polished  
Each

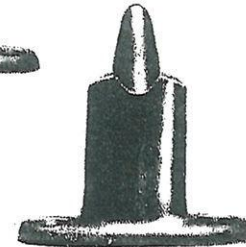

\$15.50

SINGLE WIDE-BASE STUD  
Part No. 408  
Cast Brass  
Polished  
Each

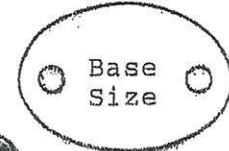

\$15.50

DOUBLE WIDE-BASE STUD  
Part No. 409  
Cast Brass  
Polished  
Each

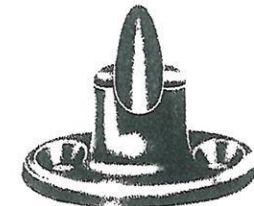

\$16.00

SINGLE CURVED-BASE STUD  
Part No. 411  
Cast Brass  
Polished  
Each

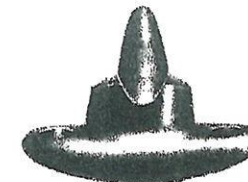

\$15.50



DOUBLE CURVED-BASE STUD

Part no. 412  
Cast Brass  
Polished  
Each



\$16.00

ROUNDED EYELET/WASHER SET

Part No. 442  
Brass  
Original early style  
formed in our dies.  
1 eyelet/washer set



\$2.00

FLAT EYELET/WASHER SET

Part No. 440  
Brass  
Common Sense fastener  
1 eyelet/washer set



\$1.00

MURPHY BACK PLATES

Part No. 415  
For attaching studs to side  
curtains, door pockets, etc.  
New, brass, each



\$1.75

SPLIT RIVETS

Part No. 416  
3/8" Length  
Just under 1/4" head Dia.  
Brass plated steel  
Package of 12



\$4.00

"THE CLIMAX" TWIST FASTENER

Part No. 141  
Single stud  
Cast Brass  
Polished  
Made from 2 castings,  
1 screw & 1 spring.  
Used on '03, '04 Winton  
and others of that era.  
Each



\$25

"THE CLIMAX" DOUBLE

Part No. 140  
Double stud  
Cast Brass  
Polished  
Accepts 2 eyelets (No. 442  
works well.)  
Each



\$28

RIBBED EYELET/WASHER SET

Part No. 445  
European style  
formed in our dies.  
Polished Brass  
1 eyelet/washer set



\$6

OAK TOP BOWS

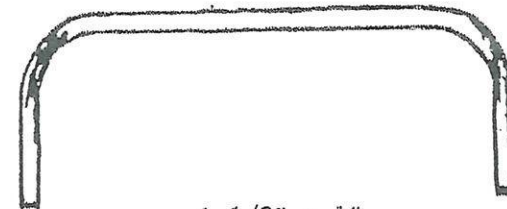

1 1/2" x 1"  
Steam Bent Oak  
Measure from outside to outside  
Prices vary according to size and quantity  
Write or Call

CABLE LOOP

51

Part No. 176  
Overall Length 2 1/4"  
For 7/8" to 1" strap  
For front top stay cable  
Used on some Oaklands,  
Cadillacs, etc.  
Brass  
Each

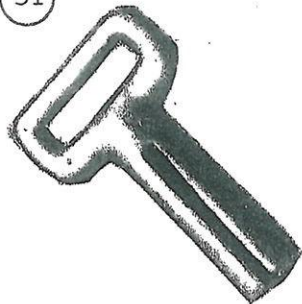

\$22

CABLE HOOK

Part No. 177  
Overall Length 2 3/4"  
For front top stay cable  
Cable solders into casting  
Brass  
Each



\$22

CADILLAC CURTAIN BRACKET

Part No. 182  
Length 1 1/4"  
Width 3/4"  
Height 9/16"  
Circa 1911, 1912  
Back curtain is rivited between this bracket  
and Murphy fastener.  
Brass

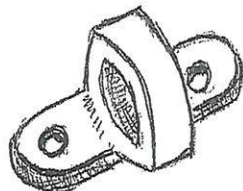

\$18

CADILLAC BACK STAY BODY BRACKET

Part No. 184  
Overall length 6 1/8"  
Mounts on each side  
of back of body.  
Circa 1911, 1912  
Uses 2 #182 for  
each bracket.  
Brass  
Pair

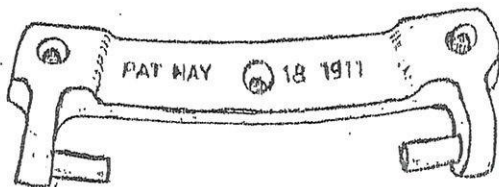

\$160

POINTED ASSIST STRAP BRACKETS

52

Part No. 189  
Height 2 1/4"  
Brass casting with  
Brass ring.  
Spring assembly keeps  
tension on ring.  
Nickel Plated  
Pair



\$170

OVAL ASSIST STRAP BRACKETS

Part No. 190  
Height 1 7/8"  
Brass casting with  
Brass ring.  
Spring assembly keeps  
tension on ring.  
Nickel Plated  
Pair



\$155

SINGLE GROOVE ASSIST STRAP BRACKETS

Part No. 191  
Overall length 2 1/4"  
Solid Brass casting  
Mounts with two #8  
oval head screws  
Nickel Plated  
Pair



\$65

TRIPLE GROOVE ASSIST STRAP BRACKETS

Part No. 560  
Overall length 2 1/4"  
Stamped brass  
Mounts with two #8  
oval head screws  
Chrome Plated  
Pair



\$30

53

NARROW BASE ASSIST STRAP BRACKETS

Part No. 561  
Overall length 2 3/8"  
Stamped steel  
Mounts with two #10  
oval head screws  
Nickel Plated  
New Old Stock  
Pair



\$25

SPECIAL ORDER INTERIOR TRIMMINGS

TWISTED CORD ASSIST STRAPS  
Part No. 570  
Length about 10 1/2"  
Crocheted band at top.  
Brass bell is covered  
and crocheted above  
the pompom.  
Twisted cord surrounds  
a spring originally done.  
Need your interior colors  
for best color choice.  
Made on your original  
assist strap brackets  
or add the cost of ours.  
Pair



\$450

POMPOM WINDOW SHADE PULLS

Part No. 575  
Normal size  
Crocheted bell  
Need your interior colors  
for best color choice.  
Each



\$85

54

ASSIST STRAP LOOP

Part No. 157  
For 1", or 1 1/8" strap  
1/2" hole  
Various uses  
Brass

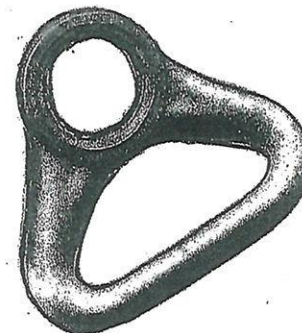

\$20

SCREW HOOK

Part No. 144  
For hat rack  
or luggage net.  
Bronze  
Each



\$15

SOLID BRASS SNAP FASTENERS

Part No. 610  
Line 24 snap fasteners  
Outside diameter is 19/32"  
Post is 5/16"  
Solid Brass (not plated)  
50 Sets of 4 pieces

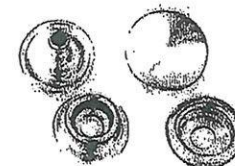

\$35

BLACK SNAP FASTENERS

Part No. 612  
Line 24 snap fasteners  
Outside diameter is 19/32"  
Post is 5/16"  
Blackened Steel  
100 Sets of 4 pieces

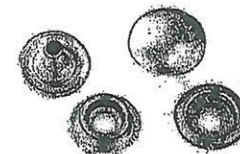

\$35

SIDE LAMP BRACKET

55

Part No. 185  
Total Height 5 1/4"  
Width 3 1/4", 2 1/2" out  
You Drill & polish  
Brass  
Pair



\$170

TAIL LAMP BRACKET

Part No. 199  
Total Height 3 3/4"  
Width 2 1/4"  
Cylindrical section  
is 1/2" at top and  
5/8" at lower end.  
You drill & polish  
Brass  
Each

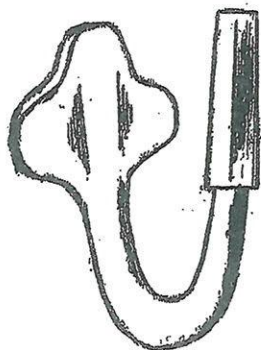

\$75

CURTAIN ROD CAP

Part No. 427  
Keeps door curtain rods  
from poking through ends  
of sleeves.  
Fits all rods up to  
1/2", round or oval.  
Black on steel.  
New old stock  
Each 2-piece set

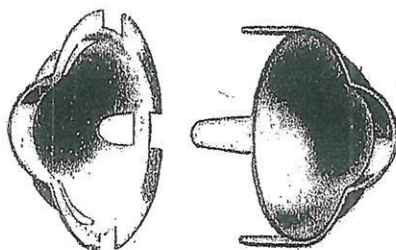

\$25

56

EUROPEAN TRUNK LATCH

Part no. 166  
Overall length 6 1/4"  
Width 1 3/4"  
Four lost-wax castings.  
You polish & fit.  
Suitable for antique &  
classic era.  
One of the best looking,  
highest quality drawbolts  
that was available.  
Brass (4 casting set)  
Each

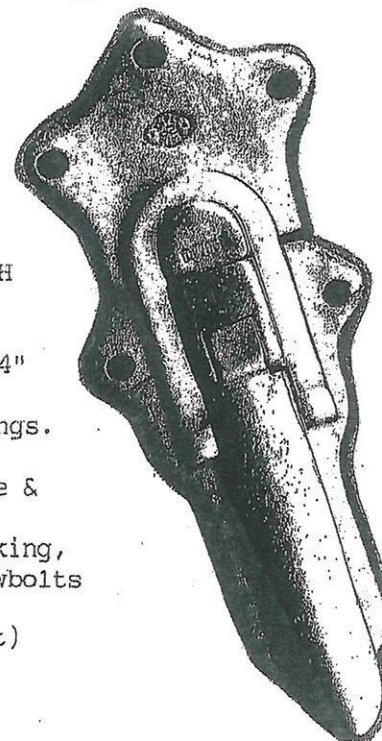

\$120

CURVED TOP EUROPEAN TRUNK LATCH

Part No. 166X  
Same as No. 166 except  
it has a curved top  
piece which is  
outlined to show the  
the shape.  
Because these parts  
are lost wax castings,  
when they are in the  
wax, the top could be  
shaped for a different  
radius on special  
order.  
Brass (4 casting set)  
Each

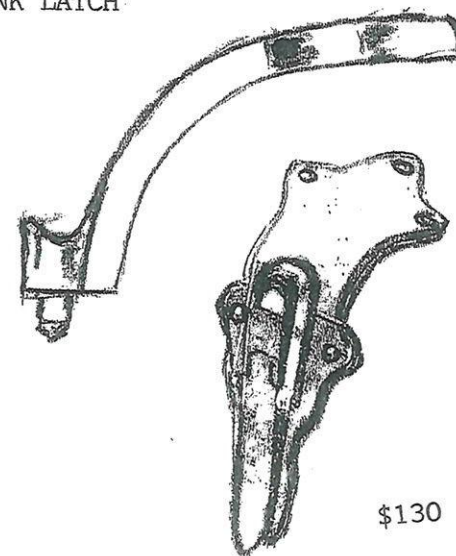

\$130

57

OCTAGON TRUNK HANDLE

Part No. 198  
 European Style  
 Used on high quality  
 trunks.  
 Screws on from inside  
 the trunk.  
 Total height is 4 1/2"  
 Width is 3"  
 Hidden limit stop keeps  
 handle at 45 degrees  
 when carrying.  
 Bronze  
 Sold in pairs  
 (2 handles and  
 2 bezels)  
 Pair

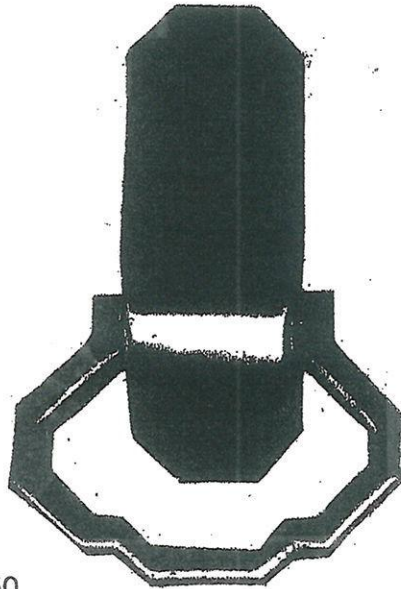

\$150

DRAWBOLT LOCK

Part No. 802  
 Size: 2" x 3 1/2"  
 With key  
 Nickel Plated  
 Steel  
 Each

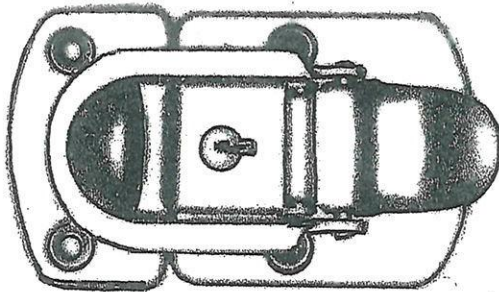

\$20

TRADITIONAL LEATHER TRUNK HANDLE

Part No. 480  
 Overall length 9 1/4"  
 Thickness is 5/16"  
 Use #481 or #482 Handle Loop  
 Sewn  
 Choose Black, Natural, Saddle  
 or Oiled Chestnut Brown leather.  
 Pair



\$95

58

9 1/2" LEATHER TRUNK HANDLE

Part No. 479  
 Overall length 9 1/2"  
 Thickness is 1/4"  
 Use #481 or #482 Handle Loop  
 Sewn  
 All Black  
 Pair

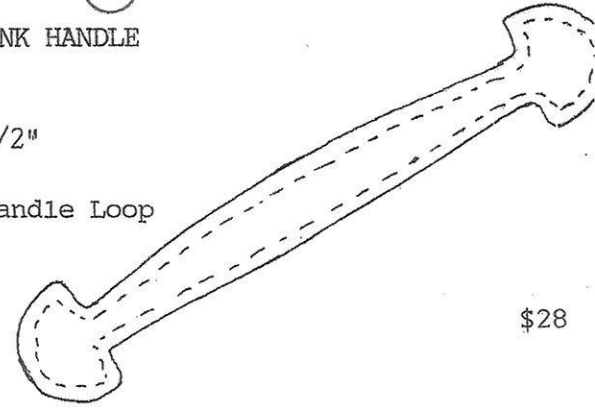

\$28

10" LEATHER TRUNK HANDLE

Part No. 485  
 Overall length 10"  
 Thickness is 1/4"  
 Use #483 or #484 Handle Loop  
 Sewn  
 All Black  
 Pair

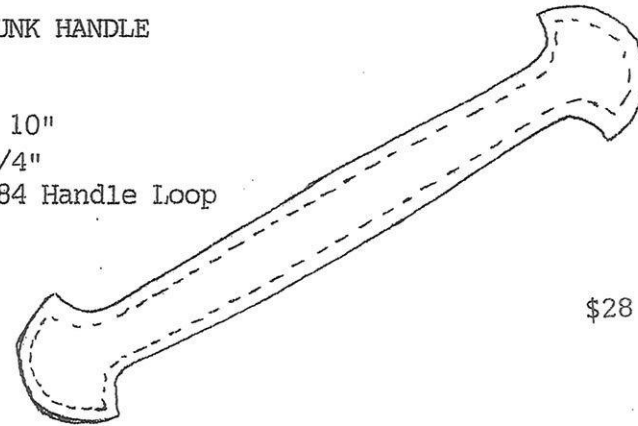

\$28

HANDLE LOOP

Part No. 481  
 Overall length 1 7/8"  
 Width is 5/8"  
 Brass plated steel  
 Each



\$3

Part No. 482  
 Nickel plated steel

\$3

Part No. 483  
 Overall length 3 1/4"  
 Width is 1 1/4"  
 Brass plated steel  
 Each

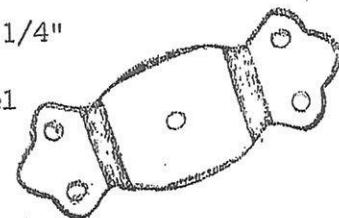

\$5

Part No. 484  
 Nickel plated steel

\$5

59

TRUNK DOWEL

Part No. 186  
 Height 2 5/8"  
 Width 2"  
 Two Brass Castings  
 Aligns trunk lid  
 Each 2-piece set

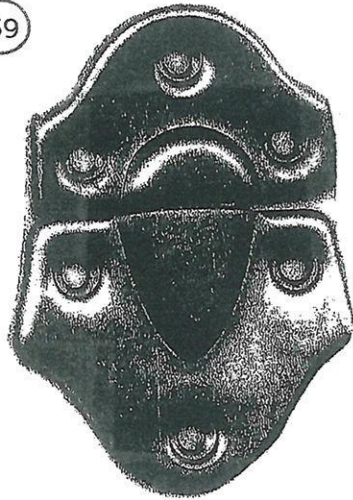

\$40

STAMPED DOWEL

Part no. 822  
 Size: 1 3/4" x 2 1/8"  
 Aligns Lid  
 Polished & Cleared  
 Solid Brass  
 Each

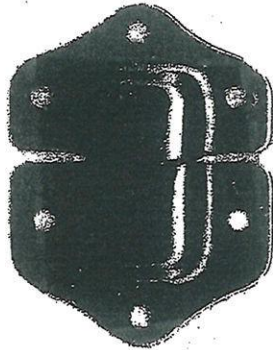

\$12

Part No. 823  
 Lide No. 822 except  
 Nickel Plated steel  
 Each

\$6

Part No. 824  
 Like No. 822 except  
 Brass Plated steel  
 Each

\$6

STOP HINGE

Part No. 840  
 Overall length 4 3/4"  
 Width 1 1/4"  
 Opens 90 degrees  
 Brass plated steel  
 Each

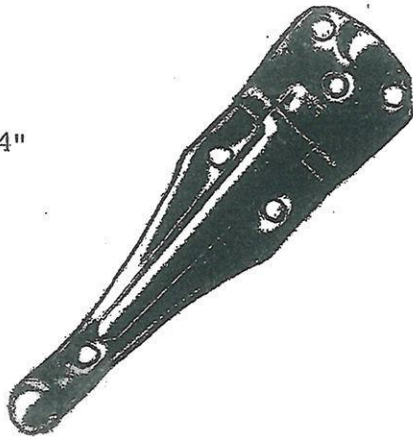

\$10

Part No. 841  
 Like No. 840 except  
 Nickel plated steel

\$10

60

BRASS OVAL HEAD SLOTTED WOOD SCREWS

#4 x 1/2"	Pkg. of 10	2.50
#4 x 3/4"	Pkg. of 10	2.50
#5 x 3/4"	Pkg. of 10	2.50
#6 x 1/2"	Pkg. of 10	2.50
#6 x 5/8"	Pkg. of 10	2.50
#6 x 3/4"	Pkg. of 10	2.50
#8 x 1"	Pkg. of 6	2.50
#8 x 1 1/4"	Pkg. of 6	3.00
#10 x 1"	Pkg. of 4	2.50
#10 x 1 1/4"	Pkg. of 4	3.00
#10 x 1 1/2"	Pkg. of 4	3.50
#12 x 1 1/2"	Pkg. of 4	4.00



BRASS COUNTERSUNK FINISHING WASHERS

#4	Pkg. of 12	.75
#6	Pkg. of 12	.75
#8	Pkg. of 12	1.00
#10	Pkg. of 12	1.25
#12	Pkg. of 12	1.25
#14	Pkg. of 12	1.75



SOLID BRASS RIVETS & BURRS

Part No. 601  
 #9 Flat head (1/2" Dia)  
 Burrs are 7/16" Dia  
 Length 1"  
 Solid Brass is more attractive  
 and causes less decay than copper.  
 Package of 12 sets.



\$8

NAILS & TACKS

5/16" Diameter Head Nails  
 1/2" long  
 Nickel plated  
 Pack of 100



\$12

7/16" Diameter Head Nails  
 1/2" long  
 Gloss black  
 Most popular for top  
 and interior trim.  
 Pack of 100



\$12

#6 Brass Gimp Tacks  
 1/8" Diameter Head  
 1/2" long  
 1/4 pound



\$12

#4 Steel Gimp Tacks  
 Black Zinc  
 1/4 pound



\$12

#6 Steel Gimp Tacks  
 Black Zinc  
 1/4 pound



\$12

#6 Trunk Tacks  
 1/4" Head  
 Black Zinc  
 1/2" long  
 1/4 pound



\$12

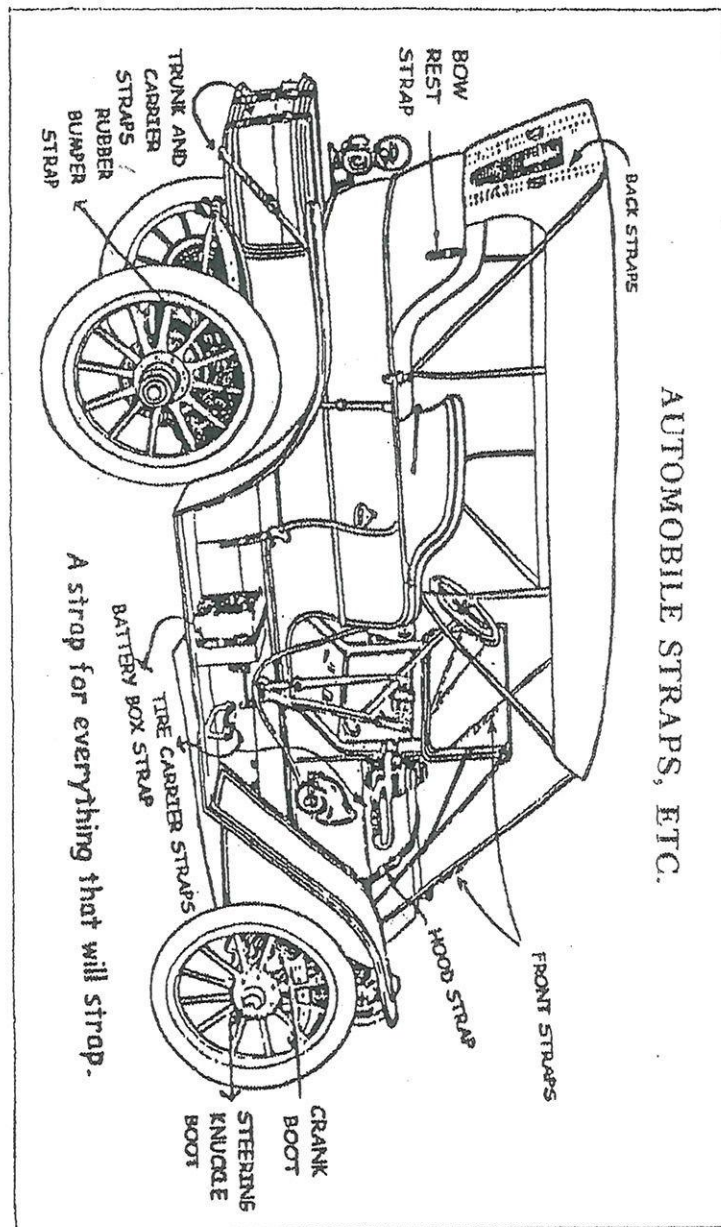

AUTOMOBILE STRAPS, ETC.

