

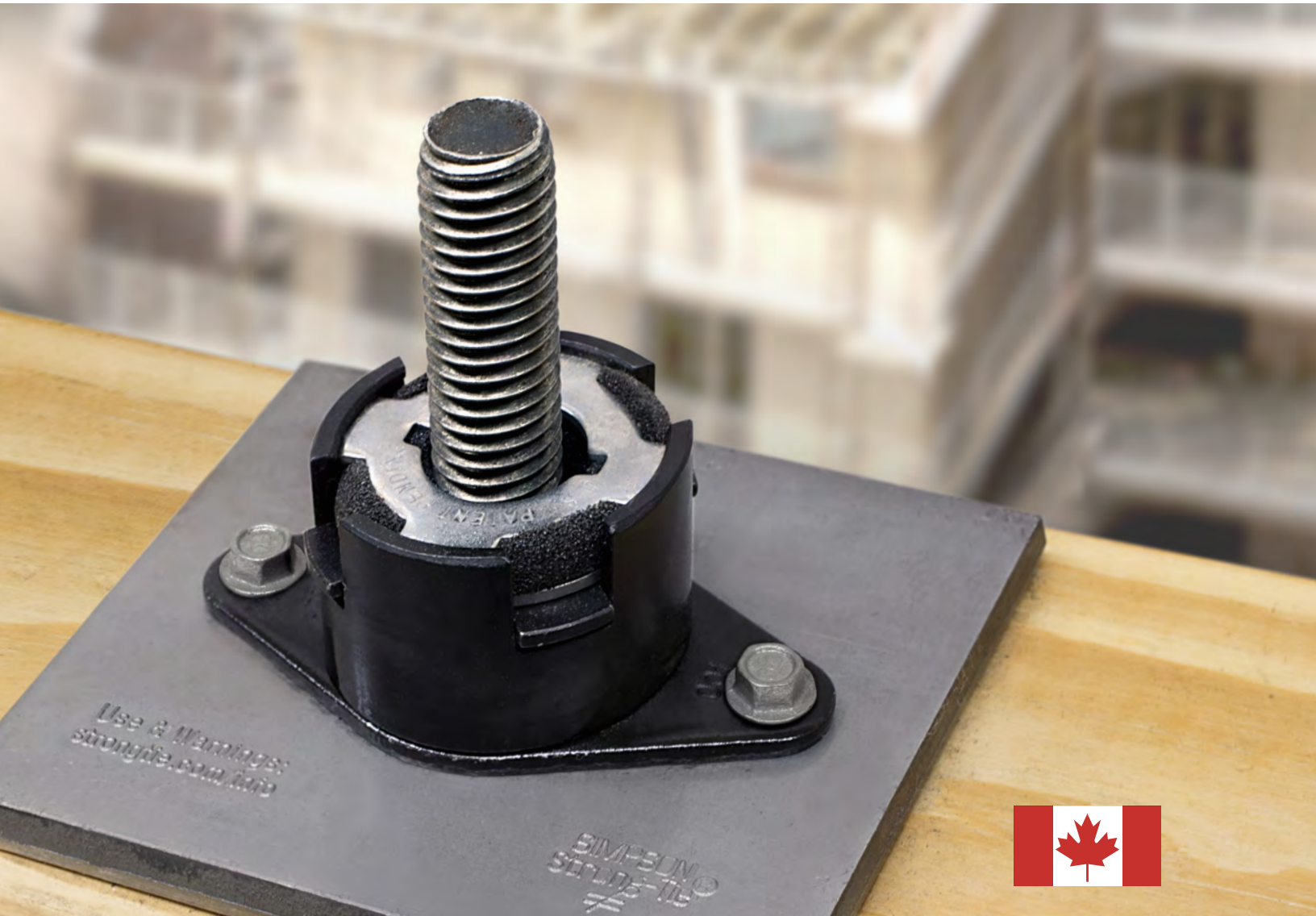

Strong-Rod™ Systems



SEISMIC AND WIND ANCHOR TIEDOWN SYSTEM GUIDE



Smart design from product to project

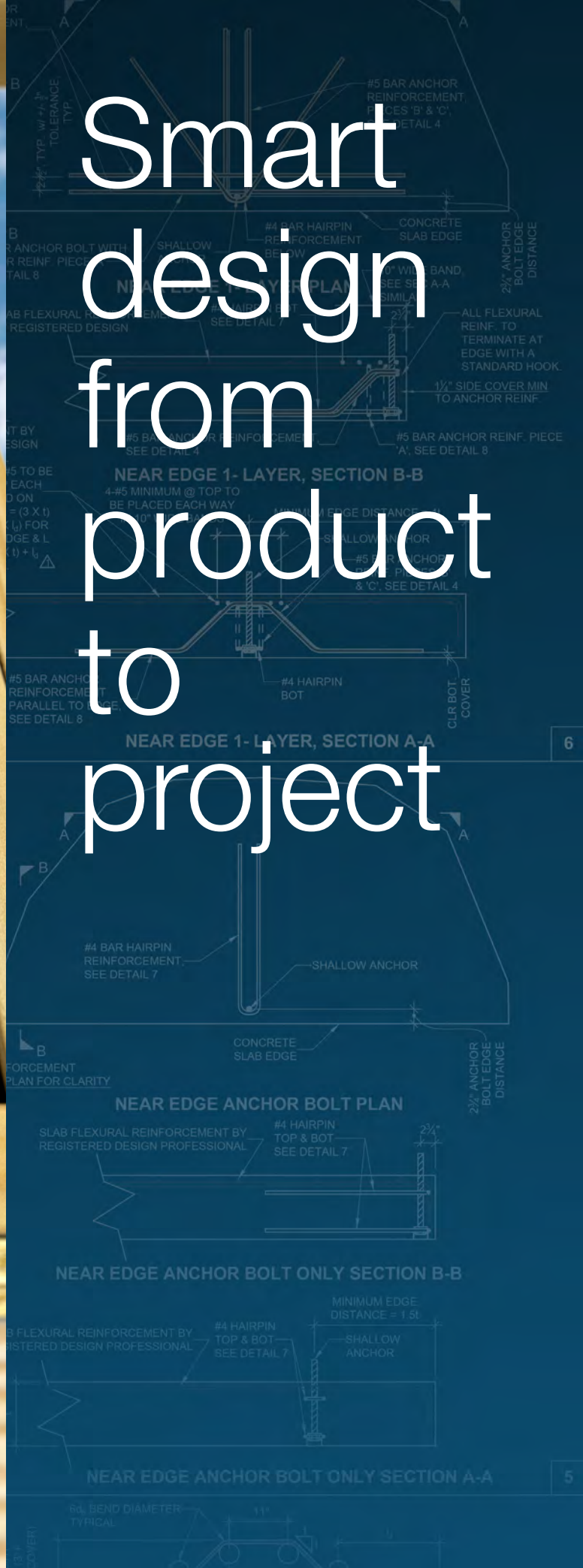

Product Design

We put our product designs through rigorous testing at our cutting-edge research and development facilities in order to deliver best-in-class structural solutions to the market. Our high-performance Strong-Rod™ systems are used for securing mid-rise, wood-framed buildings against forces caused by seismic and wind events. With innovative components that work together to create a continuous load path, Simpson Strong-Tie rod systems are built for maximum resilience and installation efficiency.

Engineering Design Services

No company knows light-frame wood construction better than Simpson Strong-Tie. Our design support services provide the technical expertise needed to tackle the complex challenges posed by mid-rise buildings. Using your project's unique design considerations and specifications, we can quickly create whole system designs, providing you a submittal-ready package of code-compliant components and plans to keep your project on time and within budget.

(800) 999-5099 | strongtie.com



Company Profile

For over 60 years, Simpson Strong-Tie has focused on creating structural products that help people build safer and stronger homes and buildings. A leader in structural systems research and technology, Simpson Strong-Tie is one of the largest suppliers of structural building products in the world. The Simpson Strong-Tie commitment to product development, engineering, testing and training is evident in the consistent quality and delivery of its products and services.

For more information, visit the company's website at strongtie.com.

The Simpson Strong-Tie Company Inc. No Equal pledge includes:

- Quality products value-engineered for the lowest installed cost at the highest-rated performance levels
- The most thoroughly tested and evaluated products in the industry
- Strategically located manufacturing and warehouse facilities
- National code agency listings
- The largest number of patented connectors in the industry
- Global locations with an international sales team
- In-house R&D and tool and die professionals
- In-house product testing and quality control engineers
- Member of WWTA, OWTFA, QWTFA, AWTF, WRLA, LBMAO, ABSDA, TPIC, and PEO



The Simpson Strong-Tie Quality Policy

We help people build safer structures economically. We do this by designing, engineering and manufacturing “No Equal” structural connectors and other related products that meet or exceed our customers’ needs and expectations. Everyone is responsible for product quality and is committed to ensuring the effectiveness of the Quality Management System.

Karen Colonias
Chief Executive Officer

Getting Fast Technical Support

When you call for engineering technical support, we can help you quickly if you have the following information at hand.

- Which Simpson Strong-Tie literature piece are you using? (See the back cover for the form number.)
- Which Simpson Strong-Tie product or system are you inquiring about?
- What is your load requirement?

We Are ISO 9001-2008 Registered

Simpson Strong-Tie is an ISO 9001-2008 registered company. ISO 9001-2008 is an internationally-recognized quality assurance system that lets our domestic and international customers know they can count on the consistent quality of Simpson Strong-Tie® products and services.



Table of Contents

Important Information and General Notes	6-7
Mid-Rise Wood-Frame Construction Permitted in Multiple Jurisdictions	8
Why Continuous Rod Tiedown Systems?	9-10
Strong-Rod™ Anchor Tiedown System (ATS) for Shearwall Overturning Restraint	11
What Is the Load Path?	12
Building Lateral Deflection and Shrinkage Compensation Devices	13-14
Key Considerations for Designing a Strong-Rod ATS	15-18
Strong-Rod ATS Components	19-36
Rod System Design Considerations for Shearwall Overturning Restraint	37
Specifying Rod Systems for Shearwall Overturning Restraint	
Specify Pre-Engineered Runs	38-40
Handling Deferred Submittals	41
Strong-Rod ATS Pre-Engineered Runs	
One-Storey Systems	42-43
Two-Storey Systems	44-45
Three-Storey Systems	46-50
Four-Storey Systems	51-55
Five-Storey Systems	56-63
Six-Storey Systems	64-71
Strong-Rod ATS Run Termination Details	72
Strong-Rod ATS Run Start Details	73
Additional Solutions for Light-Frame, Multi-Storey Wood Construction	74-75



**Let Simpson Strong-Tie
Help Design Your System.**

Here's how to reach us:

- **(800) 999-5099**
- **strongtie.com/srscontact**

General Notes for the Designer

1. Simpson Strong-Tie reserves the right to change specifications, designs, and models without notice or liability for such changes.
2. The term “Designer” used throughout this catalogue is intended to mean a qualified licensed professional engineer or a qualified licensed architect.
3. When designing for shearwall overturning restraint, the Designer is responsible for verifying that the building drift is within the acceptable code limitations. Based on U.S. Building Code requirements, Simpson Strong-Tie suggests that rod elongation and shrinkage compensating device deflection for limit states loads be limited to 0.30" or 7.6mm at each level or between restraints.
4. Steel used for each Simpson Strong-Tie® product is individually selected based on the product's steel specifications, including strength, thickness, formability, finish and ability to weld. Contact factory for steel information on specific products.
5. The Designer is responsible for verifying that all design loads do not exceed the catalogue resistance listed for each component in the restraint system.
6. Unless otherwise noted, dimensions are in inches, loads are in pounds.
7. Wood shrinks and expands as it loses and gains moisture content, particularly perpendicular to its grain. Take wood shrinkage into account when designing and installing connections. The effects of wood shrinkage are increased in multiple lumber connections, such as floor-to-floor installations. This may result in the nuts for the vertical rod system becoming loose, requiring tightening (unless shrinkage compensating devices are installed). Refer to the wood shrinkage web application on www.strongtie.com/software for more information. See ICC-ES ESR-2320 for additional information on Simpson Strong-Tie take-up devices. Clause A.5.4.6 of CSA O86-14, Chapter 5 of *Mid-Rise Wood-Frame Construction Handbook Special Publication SP-57E*, and Clause 5.3 of *Technical and Practice Document* by APEGBC. Pre-engineered runs assume a maximum shrinkage of 1/2 inch per floor (storey).
8. All connected members, studs, posts, blocking details, and related elements shall be designed by the Designer. Where multiple members of lumber are intended to act as one unit, they must be fastened together to resist the applied load.
9. Local and/or regional building codes may require meeting special conditions, such as rod elongation limits or special inspection of anchors installed in concrete and masonry. For compliance with these requirements, it is necessary to contact the local and/or regional building authority.
10. Components should be kept in a dry environment to limit exposure to moisture and corrosion. Corrosion information may be found at www.strongtie.com/corrosion.
11. Anchorage solutions shall be specified by the Designer. Foundation size and reinforcement shall be specified by the Designer. Contact Simpson Strong-Tie to coordinate connecting components at the first level.
12. The Simpson Strong-Tie® Strong-Rod™ Anchor Tiedown System for shearwall overturning restraint (Strong-Rod ATS) is designed to be installed floor-by-floor as the structure is built. Installation in this manner, with shearwalls, will provide lateral stability during construction.
13. Do not specify welding of products listed in this catalogue unless this publication specifically identifies a product as acceptable for welding, or unless specific approval for welding is provided in writing by Simpson Strong-Tie. Cracked steel due to unapproved welding must be replaced.
14. Simpson Strong-Tie strongly recommends the following addition to construction drawings and specifications: “Simpson Strong-Tie® connectors and tiedown components are specifically designed to meet the structural loads specified on the plans or provided by the Designer. Before substituting an alternate rod system, confirm that load capacity and system displacement (rod elongation and shrinkage compensation device displacement) are based on reliable published testing data and/or calculations. The Designer should evaluate and give written approval for substitution prior to installation.”
15. Steel bearing plates shall be sized for proper length, width and thickness based on steel bending capacity and wood bearing. Deflection of bearing compression (up to 0.04" or 1 mm) must be included in overall shearwall deflection calculations.
16. Available Strong-Rods, fully threaded rod sizes and material grades are listed at strongtie.com/srs.

Important Information and General Notes

General Instructions for the Installer

These general instructions for the installer are provided to ensure proper selection and installation of Simpson Strong-Tie Company Inc. products and must be followed carefully. These general instructions are in addition to the specific installation instructions and notes provided for each particular product, all of which should be consulted prior to and during installation.

1. All specified products must be installed according to the instructions in this catalogue. Incorrect quantity, size, placement, or type may cause the product to fail.
2. Use the materials specified in the installation instructions. Substitution of or failure to use specified materials may cause the connection to fail.
3. Do not add fastener holes or otherwise modify Simpson Strong-Tie Company Inc. products. The performance of modified products may be substantially weakened. Simpson Strong-Tie will not warrant or guarantee the performance of such modified products.
4. Install products in the position specified in the catalogue.
5. Do not alter installation procedures from those set forth in this catalogue.
6. Some components may have premature failure if exposed to moisture. These components are recommended to be used in dry interior applications.
7. Use proper safety equipment.
8. Welding galvanized steel may produce harmful fumes; follow proper welding procedures and safety precautions. Welding should be in accordance with CSA W59 and the Canadian Welding Bureau standards. Unless otherwise noted, Simpson Strong-Tie connectors cannot be welded.
9. The installer may cut Strong-Rod™ threaded rod or other threaded rod to length as required.
10. Shearwall sheathing shall not have vertical joints at any of the specified compression members except at the shearwall perimeter.
11. See pp. 29 and 31 for shearwall edge nailing details.
12. When installing hex nuts on the Strong-Rod™ threaded rod, make the nut snug on the bearing plate and tighten an additional ½ turn.

Limited Warranty

Simpson Strong-Tie Company Inc. warrants catalogue products to be free from defects in material or manufacturing. Simpson Strong-Tie Company Inc. products are further warranted for adequacy of design when used in accordance with design limits in this catalogue and when properly specified, installed and maintained. This warranty does not apply to uses not in compliance with specific applications and installations set forth in this catalogue, or to non-catalogue or modified products, or to deterioration due to environmental conditions.

Simpson Strong-Tie® connectors are designed to enable structures to resist the movement, stress and loading that results from impact events such as earthquakes and high-velocity winds. Other Simpson Strong-Tie products are designed to the load capacities and uses listed in this catalogue. Properly-installed Simpson Strong-Tie products will perform in accordance with the specifications set forth in the applicable Simpson Strong-Tie catalogue. Additional performance limitations for specific products may be listed on the applicable catalogue pages.

Due to the particular characteristics of potential impact events, the specific design and location of the structure, the building materials

used, the quality of construction, and the condition of the soils involved, damage may nonetheless result to a structure and its contents even if the loads resulting from the impact event do not exceed Simpson Strong-Tie catalogue specifications and Simpson Strong-Tie connectors are properly installed in accordance with applicable building codes.

All warranty obligations of Simpson Strong-Tie Company Inc. shall be limited, at the discretion of Simpson Strong-Tie Company Inc., to repair or replacement of the defective part. These remedies shall constitute Simpson Strong-Tie Company Inc.'s sole obligation and sole remedy of purchaser under this warranty. In no event will Simpson Strong-Tie Company Inc. be responsible for incidental, consequential, or special loss or damage, however caused.

This warranty is expressly in lieu of all other warranties, expressed or implied, including warranties of merchantability or fitness for a particular purpose, all such other warranties being hereby expressly excluded. This warranty may change periodically — consult our website strongtie.com for current information.

Terms and Conditions of Sale

Product Use

Products in this catalogue are designed and manufactured for the specific purposes shown, and should not be used with other connectors not approved by a qualified Designer. Modifications to products or changes in installations should only be made by a qualified Designer. The performance of such modified products or altered installations is the sole responsibility of the Designer.

Indemnity

Customers or Designers modifying products or installations, or designing non-catalogue products for fabrication by Simpson Strong-Tie Company Inc. shall, regardless of specific instructions to the user, indemnify, defend and hold harmless Simpson Strong-Tie Company Inc. for any and all claimed loss or damage occasioned in whole or in part by non-catalogue or modified products.

Non-Catalogue And Modified Products

Consult Simpson Strong-Tie Company Inc. for applications for which there is no catalogue product, or for connectors for use in hostile environments, with excessive wood shrinkage, or with abnormal loading or erection requirements.

Non-catalogue products must be designed by the customer and will be fabricated by Simpson Strong-Tie in accordance with customer specifications.

Simpson Strong-Tie cannot and does not make any representations regarding the suitability of use or load-carrying capacities of non-catalogue products. Simpson Strong-Tie provides no warranty, express or implied, on non-catalogue products. F.O.B. Shipping Point unless otherwise specified.

Mid-Rise Wood-Frame Construction Permitted in Multiple Jurisdictions



In Canada, wood-frame construction is the most common type of construction in low- to mid-rise residential buildings.



On April 6, 2009, the British Columbia Building Code was revised to permit the construction of five- and six-storey mid-rise buildings to be made in wood. This code change, and the subsequent construction of every six-storey residential structure built with wood in Canada, is in part a result of the full-scale NEESWood Capstone tests performed on the world's largest shake table in Miki, Hyogo, Japan. As of early 2015, the jurisdictions of Alberta (May 1, 2015), Ontario (January 1, 2015), and Quebec (May 2013) have permitted the building of five- and six-storey mid-rise wood-frame construction.

The NEESWood Capstone testing subjected a full-scale, six-storey, wood-framed residential building to several severe earthquake motions. The structure was built using the Simpson Strong-Tie® Anchor Tiedown System (ATS) as the primary overturning restraint. It withstood the simulation and was structurally intact after the test.

The NEESWood Capstone test program was led by Colorado State University in cooperation with Simpson Strong-Tie. Major funding was provided by the National Science Foundation (U.S.), the government of British Columbia, the government of Japan, the U.S. Forest Products Laboratory and FPIInnovations. This testing program validated the belief that six-storey wood buildings can, indeed, be built economically to withstand large seismic events.

In support of this code development, a standard of engineering that includes structural, fire, and seismic concerns has been addressed by experts on the Canadian Commission on Building and Fire Codes committees. The development of the structural engineering standard will help guide the way Designers work

with mid-rise wood-frame construction. Some design guides include *The APEGBC Technical and Practice Bulletin governing the Structural, Fire Protection, and Building Envelope Professional Engineering Services for 5- and 6-Storey Wood Frame Residential Building Projects (Mid-Rise Buildings)* and the *Mid-Rise Wood-Frame Construction Handbook Special Publication SP-57E* by FPIInnovations.

As the recognized leader in both holdown and continuous rod tiedown technology, as well as cutting-edge engineering concepts, Simpson Strong-Tie continues to develop the Anchor Tiedown System. ATS is a combination of components selected to most economically satisfy the demand loads and performance requirements of the structure designed under the more stringent design requirements, including structural, seismic and shrinkage criteria, of the building code. Similar to the system used in the Capstone test, this ATS is designed to meet the performance needs of mid-rise structures. Moreover, our unparalleled engineering and field support — from design through product installation — continues to foster the peace of mind Designers have come to expect from Simpson Strong-Tie.

Why Continuous Rod Tiedown Systems?



Seismic and wind events are serious threats to structural integrity and safety. All wood-framed buildings need to be designed to resist shearwall overturning and roof-uplift forces. For one- and two-storey structures, connectors (straps, hurricane ties and holdowns) have been the traditional answer. With the growth in multi-storey wood-framed structures, however, rod systems have become an increasingly popular load restraint solution.

Multi-storey structures present complicated design challenges. Frequently, the structures have larger windows and entrances, providing less space for traditional restraint systems. For all these reasons, there is increased need for restraint systems that can meet multi-storey structural demands without sacrificing installation efficiency or cost considerations.

Continuous rod tiedown systems are able to answer these demands by restraining both lateral and uplift loads, while maintaining reasonable costs on material and labor. Instead of using metal connector brackets as in a holdown system, continuous rod tiedown systems consist of a combination of rods, coupler nuts, bearing plates and shrinkage-compensation devices. These all work together to create a continuous load path to the foundation.

To contact a Simpson Strong-Tie representative for help designing your Strong-Rod™ continuous rod tiedown solution, call (800) 999-5099 or visit strongtie.com/srscontact.

Shearwall Overturning Restraint System

The tension force is a result of lateral (horizontal) forces due to a wind or seismic event. This force occurs at the end of shearwalls and its magnitude increases at lower levels as it accumulates the tension force from each level or shearwall above.

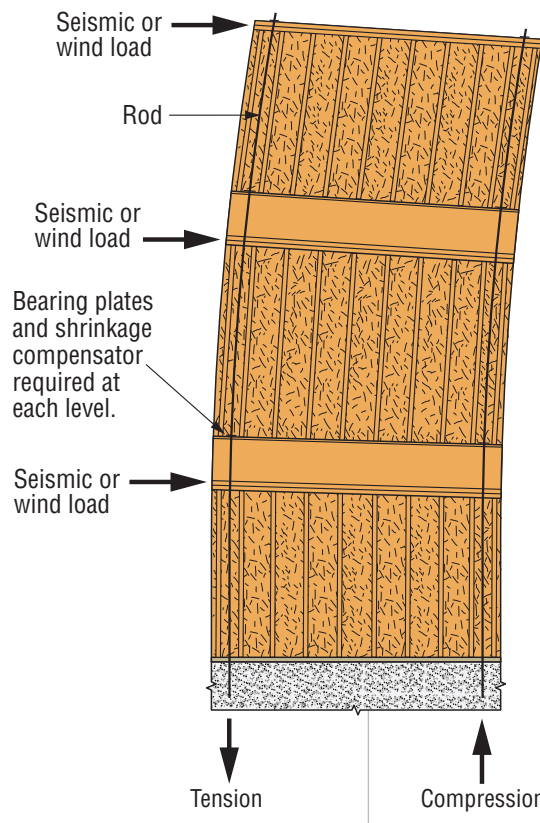

Why Continuous Rod Tiedown Systems?

Simpson Strong-Tie® Strong-Rod™ Systems

To ensure structural stability, a continuous rod tiedown system can be used in a multi-storey wood-framed structure to resist shearwall overturning and roof uplift.

Strong-Rod Anchor Tiedown Systems (ATS) solutions address the many factors that must be considered during design to ensure proper performance against shearwall overturning – such as rod elongation, wood shrinkage, construction settling, shrinkage compensating device deflection, incremental loads, cumulative tension loads and anchorage.

Simpson Strong-Tie Strong-Rod™ Systems have been extensively tested by our engineering staff at our state-of-the-art, accredited labs. Our testing and expertise have been crucial in providing customers with code-listed solutions. The Strong-Rod ATS is code-listed in the United States under the International Code Council evaluation report ICC-ES ESR-2320.

Leverage Our Expertise to Help with Your Rod System Designs

A large number of factors need to be considered when specifying a rod system:

- Wood shrinkage
- Rod elongation
- Take-up device deflection
- Construction settling
- Regional code limitations
- Local requirements

Simpson Strong-Tie is here to help you. We provide pre-engineered runs as well as highly skilled and complimentary design services to help engineers with their continuous rod design. Since no two buildings are alike, each project is optimally designed to the Designer's individual specifications. Run-assembly elevation drawings and load tables are provided to the Designer for approval. Refer to p. 41 for information regarding our Custom Design Method. For our design support services, contact your Simpson Strong-Tie representative at (800) 999-5099 or visit strongtie.com/srscontact.

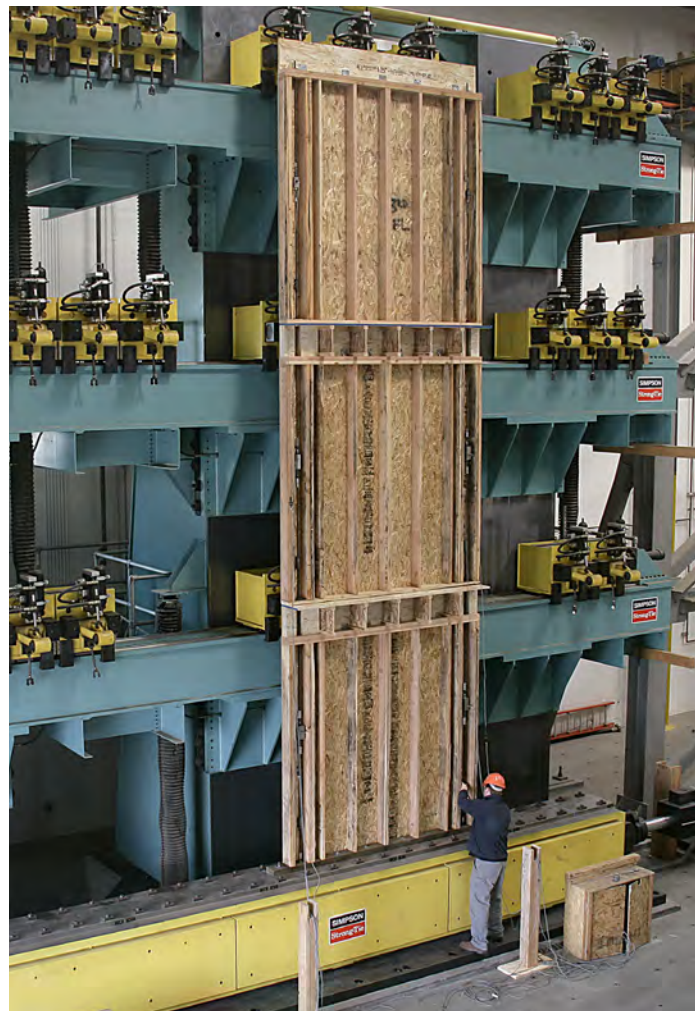

Strong-Rod™ ATS

Anchor Tiedown System for Shearwall Overturning Restraint

A continuous load path is integral to a building's structural performance. Directing the diaphragm loads from roofs and floors, through shearwalls, to the foundation in a prescribed continuous path is a widely accepted method to prevent shearwall overturning. The installation of continuous rod systems has grown in popularity with the increase in mid-rise (up to 6-storey) construction. Specifying a Strong-Rod™ Anchor Tiedown System (ATS) for shearwall overturning restraint from Simpson Strong-Tie offers several other advantages for Specifiers and installers alike:

- An ATS restraint provides the high load capacities required for mid-rise construction
- System components provide low deflection to help limit shearwall drift
- Steel tension elements of your system can be designed for the Specifier by Simpson Strong-Tie® Engineering Services
- Engineering Services can perform checks to ensure that your plans have the optimally designed system
- Our knowledge of rod system performance through years of testing ensures that all system design considerations have been met

Beyond the tension and compression aspects of a continuous rod tiedown system, wood shrinkage must also be addressed. In these types of structures, shrinkage and settlement can cause a gap to develop between the steel nut and bearing plate on the wood sole or top plate (see photo below). This can cause the system to not perform as designed and can add to system deflection. As a result, take-up devices must be used at each level to mitigate any gap creation and therefore ensure optimum system performance.



Gap between nut and bearing plate due to wood shrinkage.



Strong-Rod™ ATS

What Is the Load Path?

Traditional vs. Continuous Rod Tiedown System

A traditional shearwall relies either on holdowns or straps attached to posts to transfer the net shearwall overturning forces to the foundation.

Lateral forces are transferred from the floor/roof to the plywood sheathing. The following steps describe the traditional load path:

- Step 1. Nails are typically used to transfer loads from the sheathing to the wall framing.
- Step 2. The outermost framing boundary elements transfer the tensile forces, resulting from the net overturning, to the holddown that is attached to the post at the boundary.
- Step 3. The holddown system then transfers the load in tension to an anchor that is embedded into a concrete foundation.

A continuous rod tiedown system utilizes a combination of threaded rods with bearing plates and take-up devices at each level to transfer the forces to the foundation. The following steps describe the continuous rod tiedown system load path:

1. The end posts deliver the sheathing load to the top plates and bearing plate.
2. Bearing plate transfers the load through a nut into the rod system.
3. Rod system transfers the load from the plate through tension in the rods to the foundation.

Strong-Rod System Components to Achieve This Load Path

- Take-up devices (ATUD and TUD) allow for multiple rod diameters.
- Ratcheting take-up devices (RTUD) fit 1/2", 5/8" and 3/4" diameter rods.
- Optimized bearing plates accommodate the new ATUD and RTUD sizes.
- New options for compression post configurations that standardize anchor layout and reduce non-structural lumber in the upper stories.
- Shallow podium anchors provide test-proven solutions for anchoring high loads to relatively shallow podium slabs at interior and edge conditions in conformity with ACI 318, Anchor Provisions.

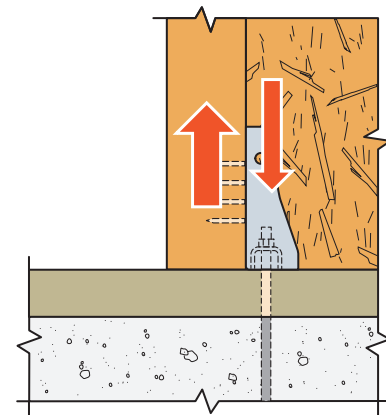

Traditional System

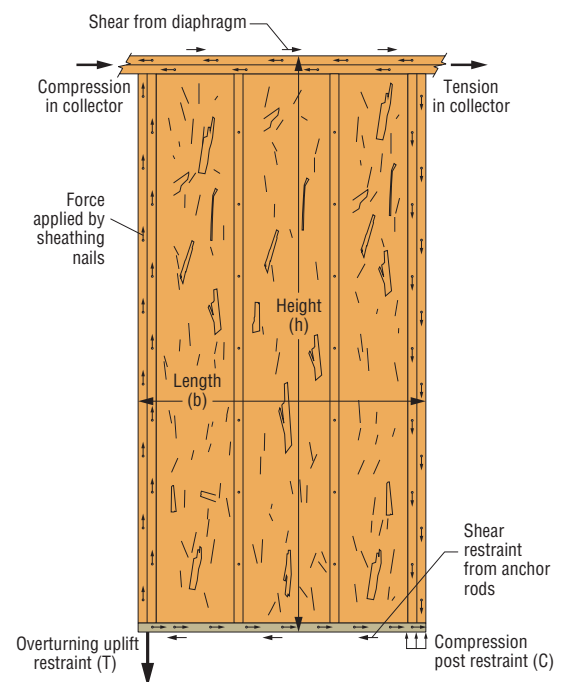

Shearwall Load Path

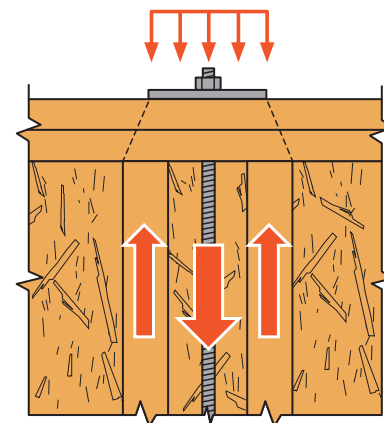

Continuous Rod Tiedown System

Building Lateral Deflection and Shrinkage Compensation Devices

In Canada, the limit for lateral deflection of a building is determined by The National Building Code of Canada. Sentence 4.1.8.13.(3) of NBC2015 limits the lateral deflection at any level to 0.025 times the height of the storey when controlled by earthquake loading in buildings not considered as post-disaster or high importance. Sentence 4.1.3.5.(3) of NBC2015 limits the lateral deflection of buildings due to service wind loads to $\frac{1}{500}$ of the storey height. Clause 11.7.1 of CSA O86-14 describes the deflection calculation of a single-storey shearwall. One of the components of the deflection calculation is d_a , which is defined as the total vertical elongation of the wall anchorage system. Factors such as fastener slip, device (shrinkage compensator and/or holdown) deflection, and anchors or rod elongation contribute to the d_a .

An integral part of the continuous rod system is the shrinkage compensation device that is used to mitigate the effects of wood shrinkage and building settlement in multi-storey wood-frame construction. The rating of these devices for use in the United States is evaluated to the International Code Council Evaluation Service (ICC-ES) Acceptance Criteria 316 (AC316). The criteria outline design and testing requirements as well as defining the method to establish rated load capacities and determining device displacements. There are two components of device displacement that are determined by AC316.

1. Device average travel and seating increment (Δ_R) is the average device movement when transitioning from actuating due to shrinkage and building settlement to resisting load during an event. This movement is independent of the applied load. It is sometimes referred to as the device looseness.
2. Device deflection at Limit States rated load (Δ_F) is the deflection of the device when loaded to the Limit States level rated load.

There are three recognized styles of shrinkage compensating devices in AC316 that are offered by Simpson Strong-Tie.

1. Compression-Controlled Shrinkage Compensating Device (CCSCD). The rod passes through the device that expands to fill the gap formed by wood shrinkage and settlement. The device resists load in compression. The Simpson Strong-Tie ATUD and TUD fit this category and are a screw style device with very low Δ_R and Δ_F values.
2. Tension-Controlled Shrinkage Compensating Device (TCSCD). This device resists tension load from the rod and actuates incrementally or through ratcheting along the rod threads. The Simpson Strong-Tie RTUD is a TCSCD. Ratcheting devices typically have higher Δ_R values.

AC316 provides a prescriptive limit for the suggested maximum vertical displacement of the continuous rod system, which includes the steel rod elongation and the shrinkage compensating device deflection, to 0.20 inch or 5 mm at each level or between restraints at allowable stress design (ASD) levels. This limit is used for the stiffness design of the continuous rod system when stiffness requirements are not specified or as a starting point in the iterative design process of evaluating strength and shearwall lateral deflection. The actual elongation requirements of the rod system run may be more or less restrictive as long as the code lateral building deflection requirements are met. For Limit States Design, the equivalent limit is 0.30 inch or 7.6 mm.



ATUD



TUD



RTUD

Strong-Rod™ ATS

This prescriptive displacement limit helps to protect the structural integrity of the shearwall bottom corners during a seismic or wind event. Excessive vertical movement can damage the sheathing connection to the sill/sole plates leading to loss of lateral resistance capacity of the shearwall system.

The prescriptive limit can be waived if the building design conforms to the calculation procedures in CSA O86-14 *Engineering Design in Wood* (Clause 11.7.1), *APEGBC Technical and Practice Bulletin*, or the *Mid-Rise Wood-Frame Construction Handbook Special Publication SP-57E* by FPIInnovations.



Sill plate split



Fastener tearing through sheathing

Key Considerations for Designing an Anchor Tiedown System for Shearwall Overturning Restraint

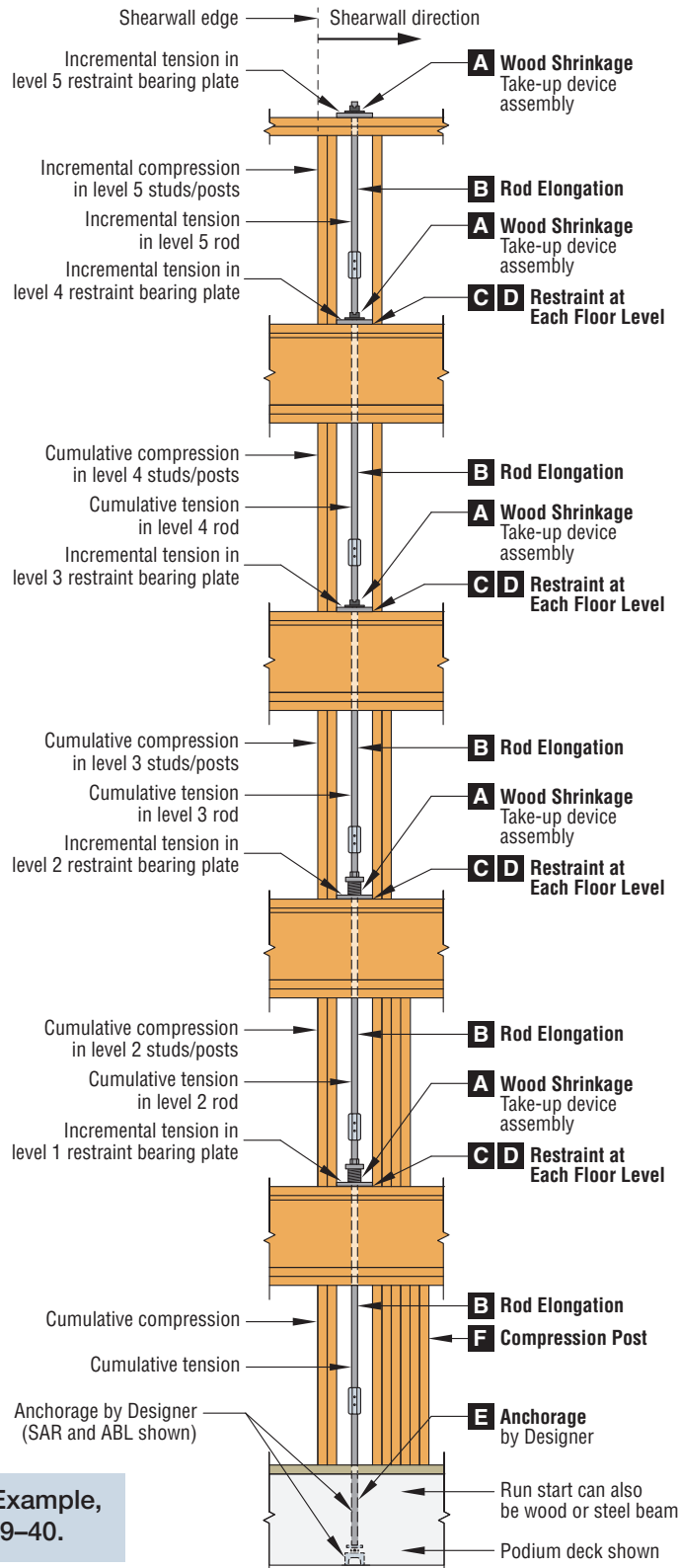

For Design Example, see pp. 39–40.

Note: Third stud may be required at shearwall edge.

Strong-Rod™ ATS

A Wood Shrinkage

CSA O86-14 *Engineering Design in Wood* and the *Mid-Rise Wood-Frame Construction Handbook* by FPIInnovations require that Designers evaluate the impact of wood shrinkage on the building structure. It is important to consider the effects of wood shrinkage when designing any continuous rod tiedown system. As wood loses moisture, it shrinks, but the continuous steel rod does not, which potentially forms gaps in the system. Wood shrinkage

can contribute to the overall lateral drift calculations but can be mitigated using shrinkage compensators and by using materials subjected to less dimensional change.

See strongtie.com/srs for additional information regarding wood shrinkage and how Simpson Strong-Tie take-up devices mitigate wood shrinkage within an Anchor Tiedown System for shearwall overturning restraint. To access our Wood Shrinkage Calculator, visit strongtie.com/software.

B Rod Elongation

A continuous rod tiedown run will deflect under load. The amount of stretch depends on the magnitude of load, length of rod, net tensile area of steel and modulus of elasticity.

In a continuous rod tiedown system designed to restrain shearwall overturning, the rod length is defined since it is tied to the storey heights and floor depths. The modulus of steel is also a constant (200,000 MPa for steel), and steel strength does not affect elongation. The only variables then per run are the load and rod net tensile area, which will be controlled by:

- Quantity, location and length of shearwalls provided to support the structure
- Choice of rod diameter

Derived from U.S. Building Code requirements, Simpson Strong-Tie suggests that rod elongation and shrinkage compensating device deflection be limited to 0.30" or 7.6 mm at each level or between restraints. Rod diameter and take-up device choice are obviously important. Simpson Strong-Tie® take-up devices (TUDs) and aluminum TUDs (ATUDs) have very little deflection ($\Delta_F + \Delta_R$) and therefore minimize the contribution of device displacement to the 0.30" or 7.6 mm deflection limit, which may allow for smaller rod diameters.

Access the Simpson Strong-Tie Rod Elongation Calculator by visiting strongtie.com/software.

C Restrain Each Floor

A skipped floor system restrains two or more floors with a single restraint point to provide overturning resistance. A continuous rod tiedown system with all floors tied-off provides overturning restraint at every floor.

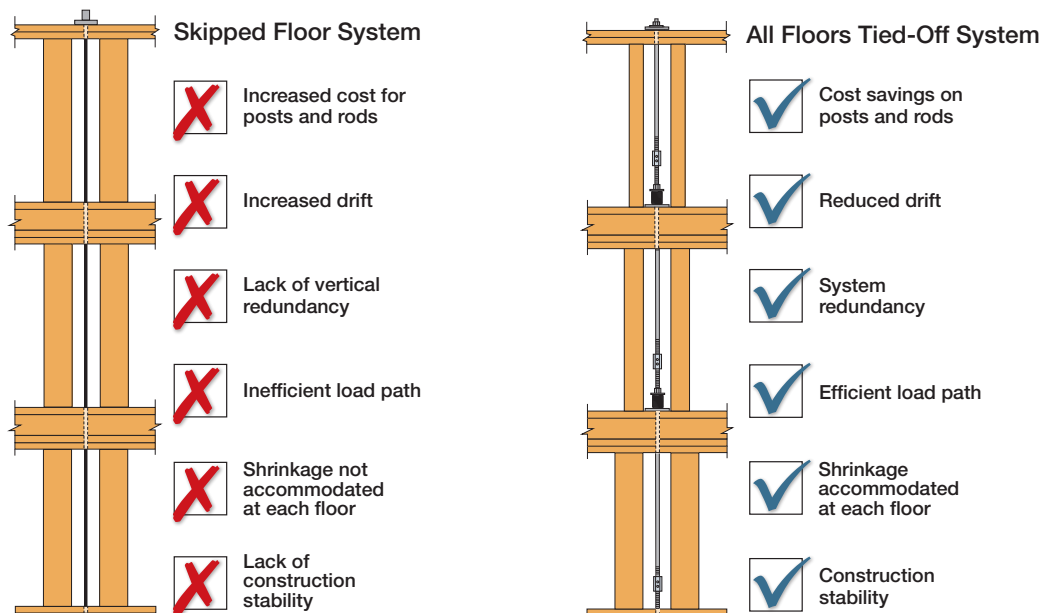

See strongtie.com/srs for additional information about the importance of providing restraint systems at each floor level.

D Bearing Plates

Bearing plates are key components in transferring loads from the posts and top plates to the rods in an Anchor Tiedown System for shearwall overturning restraint. Bearing plates must be designed to spread the loads across the sole/sill plates to minimize the effects of wood crushing and

plate bending. These plates transfer the incremental bearing loads via compression of the sole/sill plates and bending of the bearing plates to a tension force in the rod. For additional information, visit strongtie.com/srs.

E Anchorage by Designer

Many variables affect anchorage design, such as foundation type, concrete strength, anchor embedment and edge distances. Design tools, such as the Simpson Strong-Tie® Anchor Designer™ Software, are available to help the Designer navigate the complex anchorage provisions contained in the CSA A23.3 Annex D reference design standard. Anchor products, including the Pre-Assembled Anchor Bolt (PAB), are also available to simplify specification.

An elevated concrete slab, commonly referred to as a podium slab, is a common foundation type for mid-rise, light-frame construction. These slabs pose a significant challenge to designers when anchoring the continuous rod tiedown system above.

In designing light-frame structures over concrete podium slabs, lateral loads from the structure above will produce large tensile overturning forces whose demands often far exceed the breakout capacities of these relatively thin slabs. Simpson Strong-Tie has thoroughly researched and tested practical solutions that achieve the expected performance in order to provide Designers with additional design options. The use of the special detailing of anchor reinforcement shown in CSA A23.3 Annex D, Anchorage Provisions, will greatly increase the tensile capacities of the anchors.

Concrete podium slab anchorage was a multi-year test program that commenced with grant funding from the Structural Engineers Associations of Northern California, which was applied toward the initial concept testing at Scientific Construction Laboratories Inc. Following that, full-scale, detailed testing was completed at the Simpson Strong-Tie® Tye Gilb Laboratory. The concept follows code calculation procedures supported by testing of adequately designed anchor reinforcement specimens. The breakout areas in these tests were increased and spread out in a manner that is most similar to the CSA A23.3 Annex D concept of overlapping breakout areas for anchor groups. These increased breakout areas in the testing resulted in a significantly larger nominal concrete capacity that allows for larger capacities in wind-governed areas and development of larger-diameter anchors that meet the seismic anchor ductility requirements.

For assistance with your design, visit strongtie.com/srs for suggested anchorage-to-podium slab details, slab design requirements and Shallow Podium Slab Anchor Kit product information.



Anchor reinforcement testing at Tye Gilb Laboratory for edge and away-from-edge conditions.

F Compression Posts

Compression posts play an integral role in designing a Strong-Rod™ Anchor Tiedown System for shearwall overturning restraint. As tension loads are resisted by the Strong-Rod ATS, adequate compression elements are crucial in the opposite end of the shearwall. Compression posts are either single members or multiple members. A Designer may use either a symmetrical or an asymmetrical post configuration.

Symmetrical post configuration evenly distributes the multiple stud packs at each side of the steel rod at the ends of each shearwall. Common features of symmetrical configuration include the following.

- Consistent moment arm at each storey level of the shearwall
- Pyramid stack configuration at each level of the shearwall
- Equal configuration of stud packs on each side of the tension rod
- 9" maximum spacing between the stud packs

Asymmetrical post configuration distributes the same number of compression members at the shearwall ends, but the shearwall edge will always have two 2x studs while

the remainder of the studs are installed on the other side of the rod. Asymmetrical post configuration has been tested by Simpson Strong-Tie. The following features are common within an asymmetrical post configuration.

- Tension anchor bolt layout is consistent at the ends of each shearwall
- Two or three studs are always installed on the shearwall edges, maintaining a consistent shearwall edge at each storey level
- Maximum spacing between the studs is 9" for easier installation of the components
- Edge nailing is only required on the two nearest studs on each side of the rod, with field nailing at the remaining studs (see p. 31)

The Designer is responsible for determining the post configuration that best fits the need of each multi-storey wood-framed project. The design of the stud packs is the responsibility of the Designer. Simpson Strong-Tie offers guidance by providing standard tables (see pp. 29–33). Visit strongtie.com/srs for more information.

Symmetrical Posts

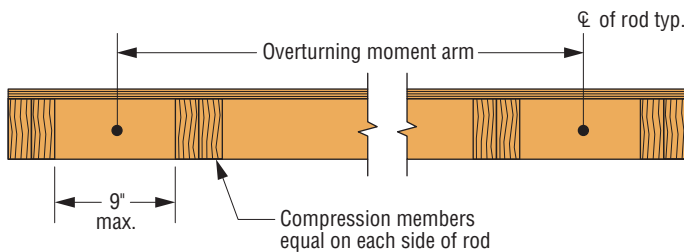

Asymmetrical Posts

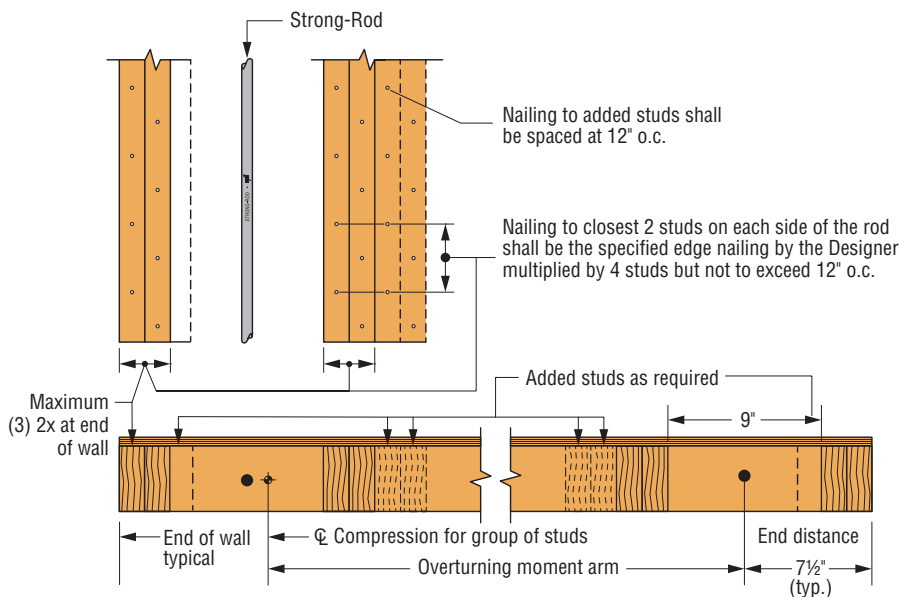

Strong-Rod™ ATS Components

A RTUD Ratcheting Take-Up Device

The RTUD ratcheting take-up device is a cost-effective shrinkage compensation solution for continuous rod systems. The RTUD is for use with rod systems to ensure highly reliable performance in a device that allows for unlimited shrinkage. Once the RTUD is installed, a series of internal threaded wedges enable the device to ratchet down the rod as the wood structure shrinks, but engage the rod in the reverse direction under tensile loading. Continuous engagement is maintained on the rod at all times by the take-up device, enabling the rod system to perform as designed from the time of installation.

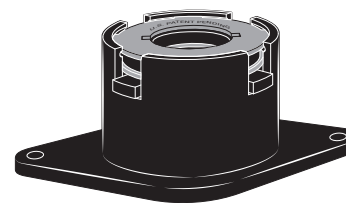

RTUD
Patent Pending

Model No.	Maximum Threaded Rod Diameter (in.)	Rated Compensation Capacity (in.)	Dimensions (in.)			Factored Resistance, P _r		Seating Increment Δ _R (in.)	Deflection at Factored Resistance Δ _F (in.)	Bearing Plate Below RTUD
			Width	Length	Height	lb.	kN			
RTUD5	⅝	Unlimited	2	3⅞	1½	17395	77.38	0.056	0.007	BPRTUD5-6B
RTUD6	¾	Unlimited	2	3⅞	1½	24995	111.19	0.057	0.011	BPRTUD5-6C

1. Thread specification for threaded rod must be UNC Class 2A, in accordance with ANSI/ASME B1.1.
2. Total device deflection = $\Delta_T = \Delta_R + \Delta_F(P_D/P_r)$
 P_D = Demand Load
 P_r = Factored compressive resistance from table
3. RTUD4B fastens to the wood plate with the BPRTUD bearing plate and (2) #9 x 1½" or 2½" Strong-Drive® SD Connector screws. RTUD5-6 fastens to the wood plate with the BPRTUD bearing plate and (2) #9 x 2½" Strong-Drive SD Connector screws. (Screws supplied.)

Naming Legend

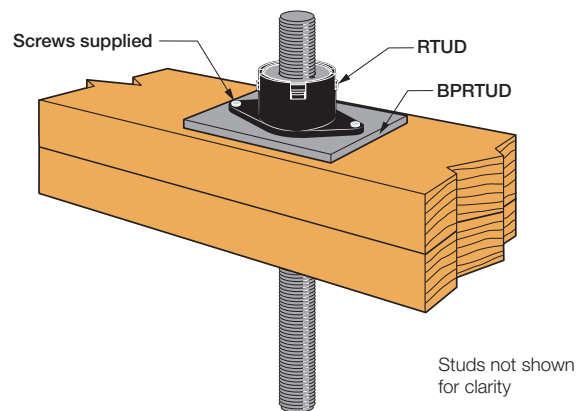
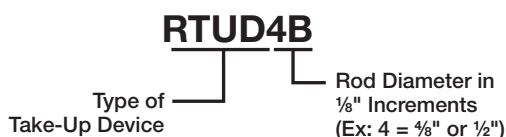

Ratcheting Take-Up Device Assembly Installation

Strong-Rod™ ATS Components

B ATUD/TUD Take-Up Device

The ATUD and TUD expanding take-up devices are suitable for rod diameters from 1/2" up to 1 3/4". Expanding screw-style take-up devices provide the lowest device displacements. For installation, ensure that the activation pin is pointing up and facing toward the inside of the building space. The pin can be pulled anytime after the nut has been tightened onto the top bearing plate and must be pulled by the time the building is fully loaded. Shrinkwrap should remain on the device until the pin is ready to be pulled. Before activating an ATUD make sure the pin on the take-up device on the floor below has been pulled. In regions with higher than normal ambient moisture, it is prudent to allow as much wood shrinkage to occur as possible before removing the activation pin. Consult with the Designer on the most effective method.

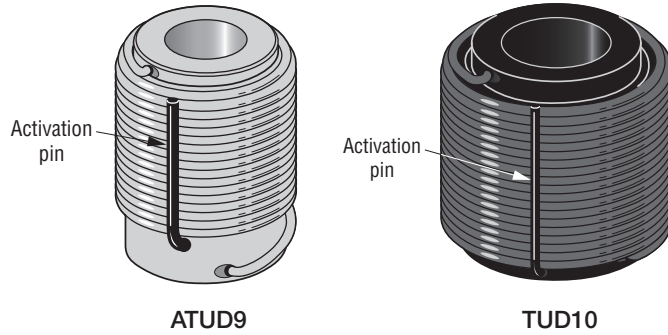

Model No.	Maximum Threaded Rod Diameter (in.)	Rated Compensation Capacity (in.)	Dimensions (in.)		Factored Compressive Resistance, P _r		Seating Increment Δ _R (in.)	Deflection at Factored Resistance Δ _F (in.)	Washer Above ATUD/TUD	Bearing Plate Below ATUD/TUD
			Width	Height	lb.	kN				
ATS-ATUD9	1 1/8	1	2 1/8	2 1/4	18670	83.05	0.002	0.014	BP	PL9
ATS-TUD10	1 1/4	1	2 3/8	2 1/4	54480	242.35	0.001	0.033	BP	PL10
ATS-ATUD6-2	3/4	2	1 3/4	2 1/8	13715	61.01	0.004	0.025	BP	PL5 / PL6
ATS-ATUD9-2	1 1/8	2	2 1/8	3 7/8	15350	68.28	0.002	0.044	BP	PL9
ATS-ATUD14-2	1 3/4	2	3	3 7/8	33970	151.11	0.002	0.018	BP	PL14
ATS-ATUD9-3	1 1/8	3	2 1/8	5	14195	63.15	0.002	0.040	BP	PL9



1. Thread specification for threaded rod must be UNC Class 2A, in accordance with ANSI/ASME B1.1.
2. Total device deflection = Δ_T = Δ_R + Δ_F(P_D/P_r)
P_D = Demand Load
P_r = Factored Compressive Resistance from table

ATUD/TUD Washer

Finish: LBP — Galvanized
BP — None

Model No.	Dimensions (in.)				Rod Diameter (in.)
	Thickness	W	L	Hole Diameter	
LBP1/2	3/4	2	2	9/16	1/2
LBP5/8	3/4	2	2	1 1/16	5/8
BP3/4	5/16	2 3/4	2 3/4	1 3/16	3/4
BP7/8	5/16	3	3	1 5/16	7/8
BP1-3	3/8	3	3	1 1/16	1
BP1-1/4	3/8	3	3	1 1/16	1 1/8, 1 1/4
BP1-1/2	3/8	3	3	1 1/16	1 3/8, 1 1/2
BP1-3/4	3/8	3	3	1 13/16	1 3/4

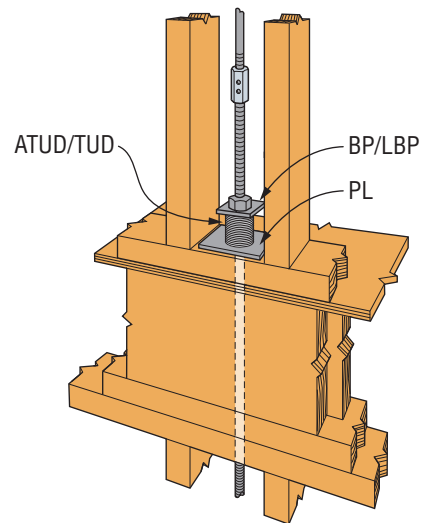

Typical Take-Up Device Assembly Installation

Strong-Rod™ ATS Components

PL and WBP Bearing Plates

Bearing plates are key components in transferring loads from the post and top plates to the rods in a continuous rod tiedown system. Bearing plates must be designed to spread the loads across the sole plates to minimize the effects of wood crushing. These plates transfer the incremental bearing loads via compression of the sole plates and bending of the bearing plates to a tension force in the rod.

Finish: PL — Gray Primer
 WBP — Gray Primer
 BPRTUD — None

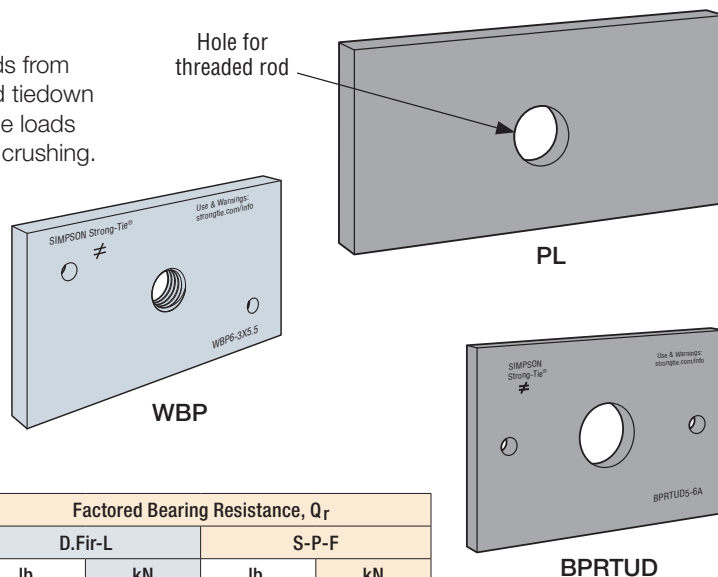

Model No.	Dimensions				Factored Bearing Resistance, Q _r			
	Width (in.)	Length (in.)	Thickness (in.)	Hole Diameter (in.)	D.Fir-L		S-P-F	
					lb.	kN	lb.	kN
For Use with RTUD Shrinkage Compensator								
BPRTUD3-4B	3	3½	3 ga.	⅝	6120	27.26	6120	27.26
BPRTUD5-6A	3	4½	3 ga.	1	7060	31.45	7060	31.45
BPRTUD5-6B	3	5½	½	1	18110	80.67	13705	61.05
BPRTUD5-6C	3	7½	¾	1	23400	104.23	17705	78.86
For Use with ATUD/TUD Shrinkage Compensator								
PL6-3x3.5	3	3½	⅜	1⅜	11420	50.87	8640	38.49
PL6-3x5.5	3	5½	½	1⅜	16835	74.99	13545	60.33
PL9-3x5.5	3	5½	½	1⅜	17095	76.15	12940	57.64
PL9-3x8.5	3	8½	⅞	1⅜	25670	114.34	19425	86.53
PL9-3x12	3	12	1¼	1⅜	34835	155.17	27960	124.54
PL9-3x15	3	15	1½	1⅜	37445	166.79	35275	157.13
PL9-5x5.5	5	5½	½	1⅜	29715	132.36	22490	100.18
PL9-5x8.5	5	8½	⅞	1⅜	43925	195.66	33240	148.06
PL9-5x12	5	12	1¼	1⅜	59135	263.41	47465	211.43
PL10-3x15	3	15	1½	1⅜	38675	172.27	35045	156.10
PL10-5x12	5	12	1¼	1⅜	61905	275.75	47235	210.40
PL14-3x8.5	3	8½	⅞	1⅜	23890	106.41	18080	80.53
PL14-3x12	3	12	1¼	1⅜	35165	156.64	26615	118.55
PL14-3x15	3	15	1½	1⅜	40560	180.67	33930	151.14
PL14-5x5.5	5	5½	½	1⅜	27815	123.90	21050	93.76
PL14-5x8.5	5	8½	⅞	1⅜	42145	187.73	31895	142.07
WBP Plates to Be Used Below Wood Beam Termination²								
WBP4-3x3.5	3	3½	½	½	11825	52.60	8950	39.81
WBP5-3x3.5	3	3½	⅝	⅝	11640	51.78	8805	39.17
WBP6-3x5.5	3	5½	¾	¾	13995	62.26	13545	60.25
WBP7-3x8.5	3	8½	⅞	⅞	24270	107.96	19825	88.19
WBP8-3x12	3	12	1	1	29470	131.09	29470	131.09
WBP8-3x15	3	15	1	1	24710	109.92	24710	109.92
WBP8-5x5.5	5	5½	1	1	28225	125.56	22710	101.02
WBP9-5x8.5	5	8½	1⅞	1⅞	43925	195.40	33240	147.86
WBP9-5x12	5	12	1⅞	1⅞	56970	253.43	47465	211.14
WBP10-5x12	5	12	1¼	1¼	58850	261.79	47235	210.12

1. Factored resistances shown are the lower of the bending capacity of the plate as per 13.5 CSA S16-14 or the bearing of the wood plates as per 6.5.7 CSA O86-14.
 2. WBP plates are to be used below wood beam termination. The smaller holes are sized to fit a ¼" x 4½" Simpson Strong-Tie® Strong-Drive® SDS Heavy-Duty Connector screw.

Strong-Rod™ ATS Components

D Coupler Nuts

CNW and ATS-C coupler nuts are used to connect one threaded rod to another and connect to anchor bolts within the Strong-Rod™ Anchor Tiedown System for shearwall overturning restraint. CNWs and ATS-C coupler nuts exceed the tensile capacity of the corresponding standard-strength threaded rod. ATS-HSC coupler nuts exceed the tensile capacity of the corresponding high-strength threaded rod. All couplers have a testing protocol to ensure that the proper loads are achieved.

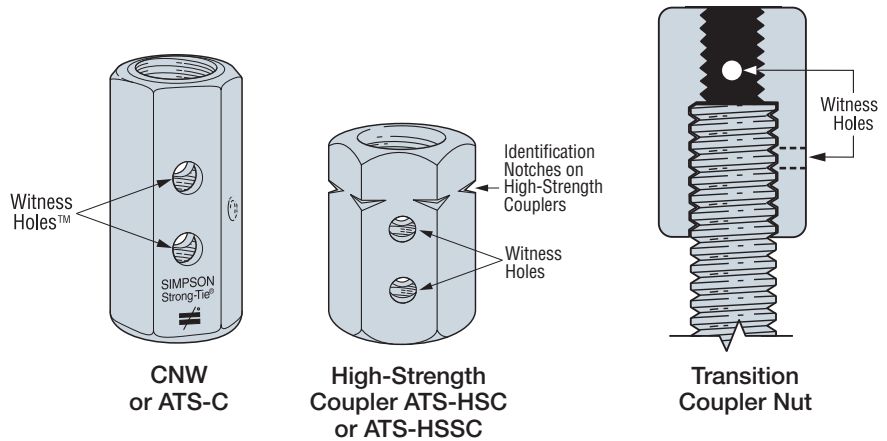

High-Strength Coupler

Standard-Strength Coupler	High-Strength Coupler										
	1/2	5/8	3/4	7/8	1	1 1/8	1 1/4	1 3/8	1 1/2	1 3/4	
1/2	ATS-HSC44	ATS-HSC54	ATS-HSC64	ATS-HSC74	ATS-HSC84	ATS-HSC94	ATS-HSC104	ATS-HSC114	ATS-HSC124	ATS-HSC144	
	CNW1/2										
5/8	ATS-C54	ATS-HSC55	ATS-HSC65	ATS-HSC75	ATS-HSC85	ATS-HSC95	ATS-HSC105	ATS-HSC115	ATS-HSC125	ATS-HSC145	
		CNW5/8									
3/4	ATS-C64	ATS-C65	ATS-HSC66	ATS-HSC76	ATS-HSC86	ATS-HSC96	ATS-HSC106	ATS-HSC116	ATS-HSC126	ATS-HSC146	
			CNW3/4								
7/8	ATS-C74	ATS-C75	ATS-C76	ATS-HSC77	ATS-HSC87	ATS-HSC97	ATS-HSC107	ATS-HSC117	ATS-HSC127	ATS-HSC147	
				CNW7/8							
1	ATS-C84	ATS-C85	ATS-C86	ATS-C87	ATS-HSC88	ATS-HSC98	ATS-HSC108	ATS-HSC118	ATS-HSC128	ATS-HSC148	
					CNW1						
1 1/8	ATS-C94	ATS-C95	ATS-C96	ATS-C97	ATS-C98	ATS-HSC99	ATS-HSC109	ATS-HSC119	ATS-HSC129	ATS-HSC149	
						ATS-C99					
1 1/4	ATS-C104	ATS-C105	ATS-C106	ATS-C107	ATS-C108	ATS-C109	ATS-HSC1010	ATS-HSC1110	ATS-HSC1210	ATS-HSC1410	
							ATS-C1010				
1 3/8	ATS-C114	ATS-C115	ATS-C116	ATS-C117	ATS-C118	ATS-C119	ATS-C1110	ATS-HSC1111	ATS-HSC1211	ATS-HSC1411	
								ATS-C1111			
1 1/2	ATS-C124	ATS-C125	ATS-C126	ATS-C127	ATS-C128	ATS-C129	ATS-C1210	ATS-C1211	ATS-HSC1212	ATS-HSC1412	
									ATS-C1212		
1 3/4	ATS-C144	ATS-C145	ATS-C146	ATS-C147	ATS-C148	ATS-C149	ATS-C1410	ATS-C1411	ATS-C1412	ATS-HSC1414	
										ATS-C1414	

Denotes standard coupler Denotes high-strength coupler

- All ATS — couplers available with one side with over-sized threads.
- All CNW couplers are zinc plated.
- All ATS — couplers come in high-strength for 3/4 inch and 1 inch size HSCNW3/4 and HSCCNW1, respectively.
- CNW couplers in the 14 series may be cylindrical.

Strong-Rod™ ATS Components

E Steel Strong-Rod

Strong-Rod threaded rods are the tension transfer element within the Anchor Tiedown System for shearwall overturning restraint. Strong-Rod threaded rods are threaded on both ends, with the top end having 48" of thread to allow for the distance that the rod sticks through the device, which can vary from a couple inches up to 48". Information clearly etched on the shank allows easy identification in the field.

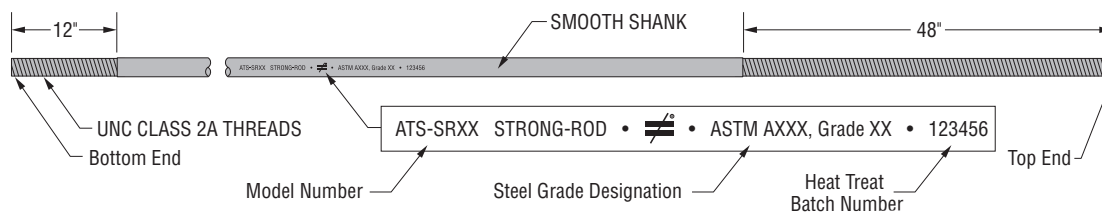
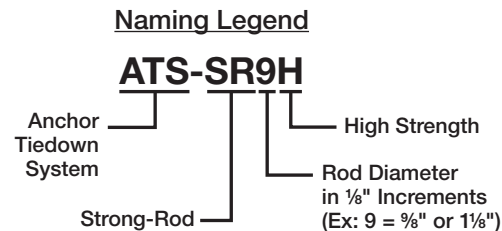

Strong-Rod

Model No.	Rod Diameter (in.)	Smooth Shank Diameter (in.)	A _g (in. ²)	A _{ne} (in. ²)	Factored Tensile Resistance, T _r		Colour Code
					lb.	kN	
ATS-SR4	1/2	0.441	0.153	0.142	5910	26.33	Yellow
ATS-SR5	5/8	0.560	0.246	0.226	9530	42.45	Blue
ATS-SR6	3/4	0.680	0.363	0.334	14055	62.61	Red
ATS-SR7	7/8	0.796	0.498	0.462	19260	85.79	Green
ATS-SR8	1	0.910	0.650	0.606	25170	112.12	White
ATS-SR9	1 1/8	1.024	0.824	0.763	31870	141.96	Orange
ATS-SR10	1 1/4	1.150	1.039	0.969	40195	179.04	Purple
ATS-SR11	1 3/8	1.265	1.257	1.160	48640	216.66	—
ATS-SR12	1 1/2	1.392	1.522	1.410	58895	262.34	—
ATS-SR14	1 3/4	1.622	2.066	1.900	79965	356.19	—
ATS-SR4H	1/2	0.441	0.153	0.142	12645	56.33	Yellow
ATS-SR5H	5/8	0.560	0.246	0.226	20340	90.60	Blue
ATS-SR6H	3/4	0.680	0.363	0.334	30060	133.90	Red
ATS-SR7H	7/8	0.796	0.498	0.462	41205	183.54	Green
ATS-SR8H	1	0.910	0.650	0.606	53850	239.87	White
ATS-SR9H	1 1/8	1.024	0.824	0.763	68190	303.74	Orange
ATS-SR10H	1 1/4	1.150	1.039	0.969	86005	383.10	Purple
ATS-SR11H	1 3/8	1.265	1.257	1.160	104065	463.54	—
ATS-SR12H	1 1/2	1.392	1.522	1.410	126010	561.29	—
ATS-SR14H	1 3/4	1.622	2.066	1.900	171000	761.69	—
ATS-SR9H150	1 1/8	1.024	0.824	0.763	85840	382.36	—
ATS-SR10H150	1 1/4	1.150	1.039	0.969	109015	485.59	—

1. Factored resistances shown are the lower of 13.2.(a)(i) and (iii), and 13.12.1.3 of CSA S16-14.
2. Simpson Strong-Tie Strong-Rod and standard all-thread rod are based on minimum F_y=43,000 psi and F_u=58,000 psi.
3. High-strength Simpson Strong-Tie Strong-Rod is based on minimum F_y=92,000 psi and F_u=120,000 psi.
4. ATS-SR9H150 high-strength Strong-Rod is based on minimum F_y = 130,000 psi and F_u = 150,000 psi.

Strong-Rod™ ATS Components

F Shallow Podium Slab Anchor Kit

The shallow podium slab anchor kit includes the patented Anchor Bolt Locator (ABL) and patent-pending Shallow Anchor Rod (SAR). Specifically designed for installation to concrete-deck forms, the ABL enables accurate and secure placement of anchor bolts. The structural heavy hex nut is attached to a pre-formed steel “chair” and becomes the bottom nut of the anchor assembly. The shallow anchor is provided with a plate washer fixed in place that attaches on the ABL nut when assembled and increases the anchor breakout and pullout capacity. The shallow anchor is easily installed before or after placement of the slab reinforcing steel or tendons. Where higher anchor capacities are needed such as at edge conditions or to meet seismic ductility requirements, the anchor kit is combined with anchor reinforcement.

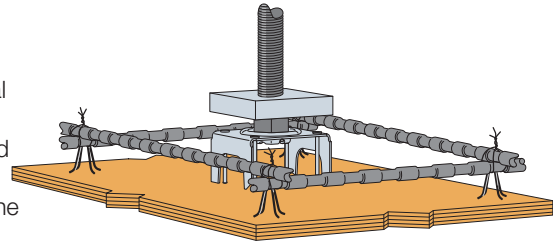

Shallow Podium Slab Anchor Kit
(rebar by Designer)

Naming Legend

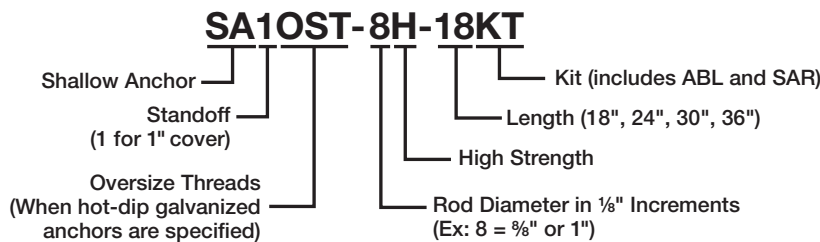

ABL Anchor Bolt Locator

The ABL enables the accurate and secure placement of anchor bolts on concrete-deck forms prior to concrete placement. The structural heavy hex nut is attached to a pre-formed steel “chair,” which eliminates the need for an additional nut on the bottom of the anchor bolt.

Features:

- Designed for optimum concrete flow
- Installs with (2) nails or (2) screws
- Provides 1" standoff (clear cover)
- Available for anchor rod diameter 1/2" to 1 1/2"
- For use with hot-dip galvanized anchor rods, specify “OST” for oversized threads

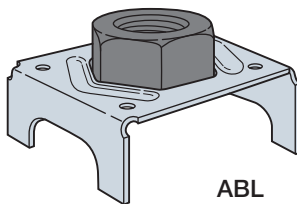

ABL
U.S. Patent 8,381,482

Model No.	Standoff (in.)	Anchor Bolt Diameter (in.)
ABL4-1	1	1/2
ABL5-1	1	5/8
ABL6-1	1	3/4
ABL7-1	1	7/8
ABL8-1	1	1
ABL9-1	1	1 1/8
ABL10-1	1	1 1/4
ABL11-1	1	1 3/8
ABL12-1	1	1 1/2

SAR Shallow Anchor Rod

SAR anchor rods are for use with the ABL anchor bolt locator. They combine to make an economical podium-deck anchorage solution. Anchorage specification is per Designer.

Features:

- Proprietary, pre-attached plate washer
- Available in standard strength or high strength
- Anchor rod diameters from 1/2" to 1 1/4"
- Standard lengths available: 18", 24", 30" or 36"
- Specify “HDG” for hot-dip galvanized

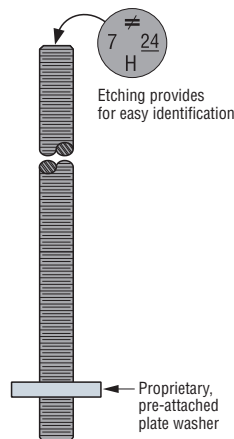

SAR
U.S. Patent Pending

Model No.	Rod Diameter (in.)
SAR4	1/2
SAR5	5/8
SAR6	3/4
SAR7	7/8
SAR8	1
SAR9	1 1/8
SAR10	1 1/4
SAR4H	1/2
SAR5H	5/8
SAR6H	3/4
SAR7H	7/8
SAR8H	1
SAR9H	1 1/8
SAR10H	1 1/4

Refer to strongtie.com/srs for capacity and anchorage details.

Strong-Rod™ ATS Components

Anchor Bolt Rod

ATS-ABR anchor bolt rods are rods for use with the ABL anchor bolt locator. When these are used with the ABL (and plate washer, if needed), they combine to make an economical podium-deck anchorage solution. Anchorage specification per Designer.

Features:

- Available in standard or high strength
- Anchor rod diameters from ½" to 1 ¾"
- Standard lengths available 18", 24", 30" or 36"
- Specify "HDG" for hot-dip galvanized

Material:

Standard (model ABRx) — min. $F_u = 58$ ksi

High-strength (model ABRxH) — up to 1" diameter — minimum $F_u = 120$ ksi;
1 ½" and 1 ¾" — minimum $F_u = 125$ ksi

Finish: None

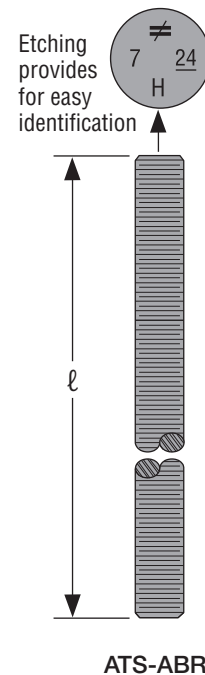

Model No.	Rod Diameter (in.)	Factored Tensile Resistance, T_r		Colour Code
		lb.	kN	
ATS-ABR4	½	5520	24.59	Yellow
ATS-ABR5	⅝	8780	39.11	Blue
ATS-ABR6	¾	12980	57.82	Red
ATS-ABR7	⅞	17955	79.98	Green
ATS-ABR8	1	23550	104.90	White
ATS-ABR9	1 ⅛	29650	132.07	Orange
ATS-ABR10	1 ¼	37655	167.73	Purple
ATS-ABR11	1 ⅝	45080	200.80	—
ATS-ABR12	1 ½	54795	244.08	—
ATS-ABR14	1 ¾	73835	328.89	—
ATS-ABR4H	½	11415	50.85	Yellow
ATS-ABR5H	⅝	18170	80.94	Blue
ATS-ABR6H	¾	26855	119.62	Red
ATS-ABR7H	⅞	37145	165.46	Green
ATS-ABR8H	1	48720	217.02	White
ATS-ABR9H	1 ⅛	63900	284.63	Orange
ATS-ABR10H	1 ¼	81155	361.49	Purple
ATS-ABR11H	1 ⅝	97150	432.74	—
ATS-ABR12H	1 ½	118085	525.99	—
ATS-ABR14H	1 ¾	159125	708.80	—

1. Factored resistances have been calculated in accordance with 25.3.2.1 CSA S16-14.
2. Anchorage calculation and specification shall conform to CSA A23.3 Annex D by the Designer.

Strong-Rod™ ATS Components

Pre-Assembled Anchor Bolt

The PAB anchor bolt is a versatile cast-in-place anchor bolt ideal for high-tension-load applications. It features a plate washer at the embedded end sandwiched between two fixed hex nuts and a head stamp for easy identification after the pour.

Features:

- Available in diameters from 1/2" to 1 1/4" in lengths from 12" to 36" (in 6" increments)
- Available in standard and high-strength steel
- Head stamp contains the No Equal sign, diameter designation and an "HS" on high-strength rods

Material:

Standard Steel — ASTM F1554 Grade 36, A36 or A307; $F_U = 58$ ksi
 High-Strength Steel (up to 1" diameter) — ASTM A449; $F_U = 120$ ksi
 High-Strength Steel (1 1/8" and 1 1/4" diameter) — ASTM A193 B7 or F1554 Grade 105; $F_U = 125$ ksi

Finish: None. May be ordered in HDG; contact Simpson Strong-Tie.

Installation:

- On HDG PABs, chase the threads to use standard nuts or couplers or use overtapped products in accordance with ASTM A563; for example, Simpson Strong-Tie® NUT 5/8"-OST, NUT 7/8"-OST, CNW 5/8"-OST, CNW 7/8"-OST. Some OST couplers are typically oversized on one end of the coupler nut only and will be marked with an "O" on oversized side. Couplers may be oversized on both ends. Contact Simpson Strong-Tie.

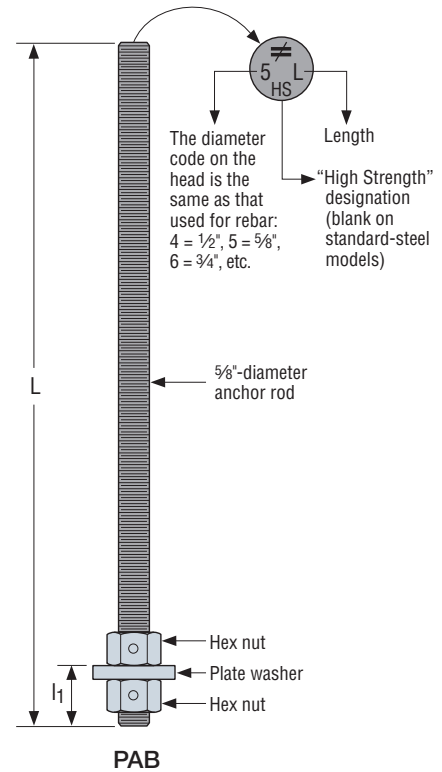

The Simpson Strong-Tie® Anchor Designer™ Software analyzes and suggests anchor solutions using the CSA A23.3 Annex D Limit States Design methodology. It provides cracked and uncracked-concrete anchorage solutions for numerous Simpson Strong-Tie Anchor Systems mechanical and adhesive anchors as well as the PAB anchor. With its easy-to-use graphical user interface, the software makes it easy for the Designer to identify anchorage solutions without having to perform time-consuming calculations by hand.

Naming Legend

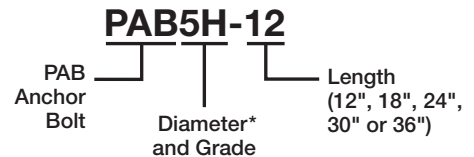

*Units in 1/8" Increments
(Ex: 9 = 9/8" or 1 1/8")

PAB Anchor Bolt

Model No.	Dimensions (in.)			Factored Tensile Resistance, T_r	
	Rod Diameter	Plate Washer Size	l_1	lb.	kN
PAB4	1/2	3/8 x 1 1/2 x 1 1/2	1	5520	24.59
PAB5	5/8	1/2 x 1 3/4 x 1 3/4	1 1/4	8780	39.11
PAB6	3/4	1/2 x 2 1/4 x 2 1/4	1 3/8	12980	57.82
PAB7	7/8	1/2 x 2 1/2 x 2 1/2	1 1/2	17955	79.98
PAB8	1	5/8 x 3 x 2 3/4	1 5/8	23550	104.90
PAB9	1 1/8	5/8 x 3 1/2 x 3 1/4	1 3/4	29650	132.07
PAB10	1 1/4	3/4 x 3 1/2 x 3 1/2	1 7/8	37655	167.73
PAB5H	5/8	1/2 x 1 3/4 x 1 3/4	1 1/4	11415	50.85
PAB6H	3/4	1/2 x 2 1/4 x 2 1/4	1 3/8	18170	80.94
PAB7H	7/8	1/2 x 2 1/2 x 2 1/2	1 1/2	26855	119.62
PAB8H	1	5/8 x 3 x 2 3/4	1 5/8	37145	165.46
PAB9H	1 1/8	5/8 x 3 1/2 x 3 1/4	1 3/4	48720	217.02
PAB10H	1 1/4	3/4 x 3 1/2 x 3 1/2	1 7/8	63900	284.63

1. Factored resistances have been calculated in accordance with 25.3.2.1 CSA S16-14.
 2. Anchorage calculation and anchorage specification shall conform to CSA A23.3 Annex D by the Designer.

Strong-Rod™ ATS Components

SET-3G™ High-Strength Epoxy Adhesive

SET-3G is the latest innovation in epoxy anchoring adhesives from Simpson Strong-Tie. Formulated to provide superior performance in cracked and uncracked concrete at elevated temperatures, SET-3G installs and performs in a variety of environmental conditions and temperature extremes. The exceptional bond strength of SET-3G results in high design strengths at shallow embedment depths.

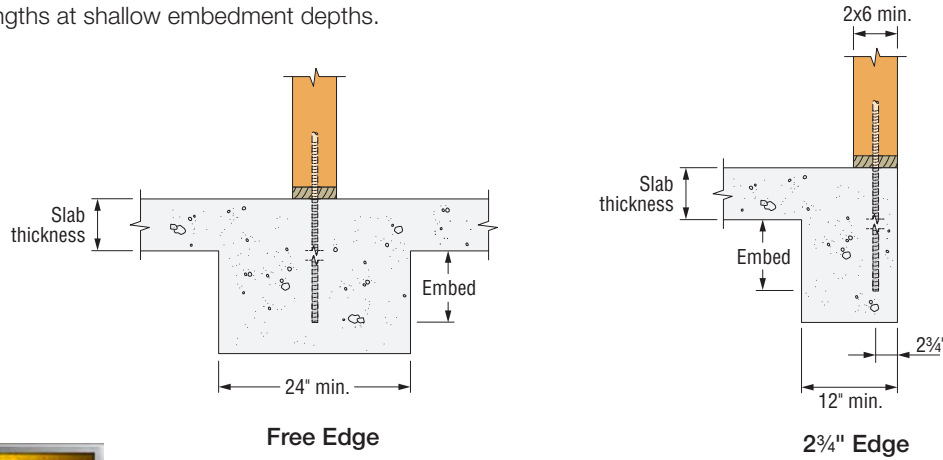

SET-3G Adhesive



For other scenarios, use our Anchor Designer™ Software.

Post Installed Anchorage Solution with SET-3G and ATS-ABR

Rod Dia. (in.)	Model No.	Factored Tensile Bond/Concrete Breakout Resistance			
		Wind			
		Uncracked			
		Embedment Depth l_e (in.)	Free Edge	Embedment Depth l_e (in.)	2 3/4" Edge
		lb.		lb.	
		kN		kN	
1/2"	ATS-ABR4	3	5870	4 1/4	5880
			26.12		26.16
5/8"	ATS-ABR5	4	9040	6 1/4	9000
			40.22		40.04
3/4"	ATS-ABR6	5 1/4	13595	10 3/4	13685
			60.47		60.88
7/8"	ATS-ABR7	6 1/2	18730	17	16780
			83.31		74.64
1"	ATS-ABR8	7 3/4	24385	20	18080
			108.46		80.43
1 1/8"	ATS-ABR9	10 1/2	27225		
			121.11		
1 1/4"	ATS-ABR10	12	28185		
			125.38		

Rod Dia. (in.)	Model No.	Factored Tensile Bond/Concrete Breakout Resistance			
		Wind / Seismic $I_e F_a S_a(0.2) \geq 0.35$			
		Cracked			
		Embedment Depth l_e (in.)	Free Edge	Embedment Depth l_e (in.)	2 3/4" Edge
		lb.		lb.	
		kN		kN	
1/2"	ATS-ABR4	5 1/2	5950	9 1/4	5645
			26.47		25.11
5/8"	ATS-ABR5	6 1/4	9080	11 1/2	7400
			40.39		32.92
3/4"	ATS-ABR6	8	13425	15	8325
			59.72		37.03
7/8"	ATS-ABR7	12	14800		
			65.84		
1"	ATS-ABR8	18	16795		
			74.71		
1 1/8"	ATS-ABR9				
1 1/4"	ATS-ABR10				

1. Published factored resistances are the lesser of adhesive bond and concrete breakout capacities, as per CSA A23.3 Annex D.
2. Anchorage calculation and specification shall conform to CSA A23.3 Annex D by the Designer.
3. Minimum concrete compression strength is 27.6 Mpa. Supplemental reinforcement assumed (condition A Tension, B Shear). Concrete assumed dry condition.
4. Factored resistances for seismic $I_e F_a S_a(0.2) \geq 0.35$ applications assume ductile yielding in the attachment. See D.4.3.5.3 CSA A23.3-14 for more information.
5. Free edge refers to no spacing restrictions, and 12" edge distance.
6. 2 3/4" Edge assumes 2x6 wood wall with one edge = 2 3/4". Anchor edge assumes $1.5l_e$ or greater from the concrete end. Provide supplementary reinforcement to resist concrete splitting as per D.6.2.7 CSA A23.3-14.
7. Compare and use the lesser of the tensile bond/concrete breakout capacity with the steel rod capacity (regular strength or high-strength rod).
8. Refer to the Simpson Strong-Tie Anchor Designer Software for all other concrete conditions and applications.

Strong-Rod™ ATS Components

NEW Rod-to-Steel-Beam Connector (ATS-SBC)

The new rod-to-steel-beam connector (ATS-SBC) features a preattached high-strength steel threaded rod and weldable plate for use on projects where the run is to be anchored to steel beams. The new connector reduces the number of components from seven to two, saving contractors installation time and cost. The design of the steel beam and the stiffeners are the responsibility of the Designer.

Material: Plate — ASTM A572 Grade 50

Threaded Rod: High-Strength (ATS-HSR):

Up to 1" diameter — ASTM A449

Greater than 1" diameter — ASTM A193 B7 or F1554 Grade 105

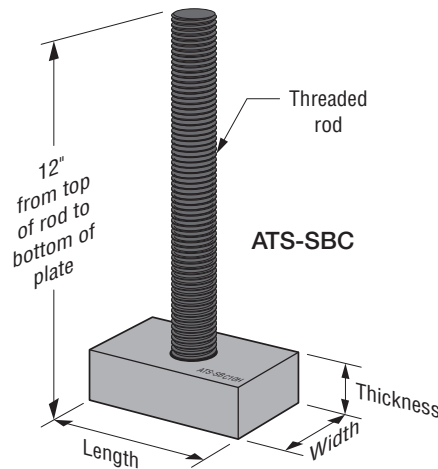

Rod-to-Steel-Beam Connector (SBC)

Model No.	Rod Diameter (in.) ³	Rod Height (in.)	Rod-to-Beam Plate Size (in.)			Fillet Weld Size (in.)	Weld Length (in.) ²	Factored Tensile Resistance T _r	
			Length	Width	Thickness			lb.	kN
ATS-SBC5H	5/8	12 (top of rod to bottom of plate)	3	3	3/4	1/4	6	20340	90.60
ATS-SBC6H	3/4		3	3	1	5/16	6	30060	133.90
ATS-SBC8H	1		3	3	1 1/4	5/16	10	53850	239.87
ATS-SBC10H	1 1/4		5	3	1 1/2	5/16	14	86005	383.10
ATS-SBC11H	1 3/8		6	3	1 1/2	5/16	16	99070	441.29
ATS-SBC12H	1 1/2		7	3	1 3/4	5/16	18	124965	556.64

1. Factored resistance is for ATS-SBC only. No further increase in factored resistance is permitted.
2. The weld length for the ATS-SBC5H and ATS-SBC6H requires only two opposing sides of the plate to be fillet welded full length less a 1/4" holdback from each of the edges. For the ATS-SBC8H up to the ATS-SBC12H, all four sides must be fillet welded full length less a 1/4" holdback from each of the edges. All fillet welds, F_{EXX}, to be greater than or equal to 70 ksi and to follow geometry and standards per CSA W59. Prepare base materials in accordance with AWS D1.1.
3. For purposes of coupling on to the rod above, the ATS-SBC threaded rod specification is UNC Class 2A, in accordance with ANSE/ASME B1.1.
4. The minimum tensile strength, F_u, of the threaded rod for the ATS-SBC5H, ATS-SBC6H and ATS-SBC8H is 120 ksi, and for the ATS-SBC10H, ATS-SBC11H and ATS-SBC12H it is 125 ksi. For rod steel ASTM specifications, see reference above.
5. A minimum flange thickness of 0.258" is required for the structural steel beam.

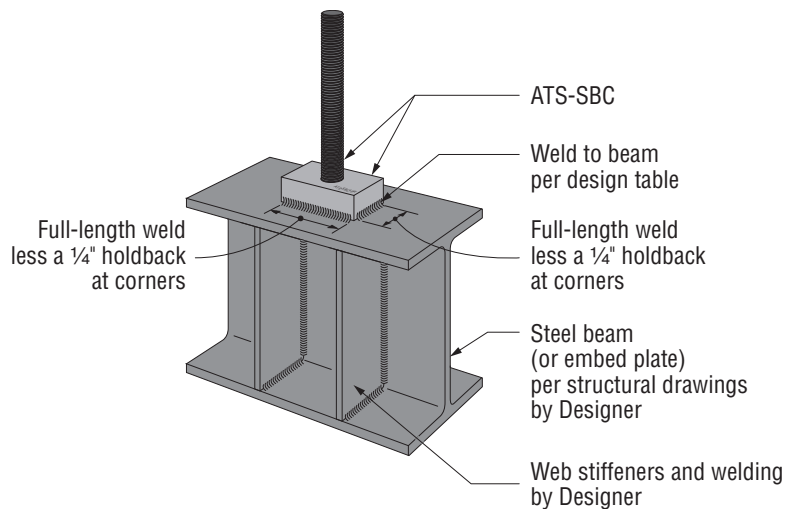

Typical Rod-to-Steel-Beam Installation

G Compression Post Recommendations

As the Strong-Rod™ Anchor Tiedown System (ATS) for shearwall overturning restraint undergoes tension loads, it is important to specify adequate compression elements to resist the compression loads. They comprise a pair of posts or built-up studs at each side of the Strong-Rod ATS. Simpson Strong-Tie has provided two options for post configurations. The configuration is determined by the Designer based on design and construction preference.

Specifications of studs and posts are the responsibility of the Designer. Simpson Strong-Tie has provided recommendations of post configurations which can be found at strongtie.com/srs. The distribution of edge nailing is important to transfer the loads appropriately. The following are some examples of recommended nail distribution between posts.

Symmetrical Posts: An equal number of posts or studs on each side of the Strong-Rod™.

Symmetrical Posts

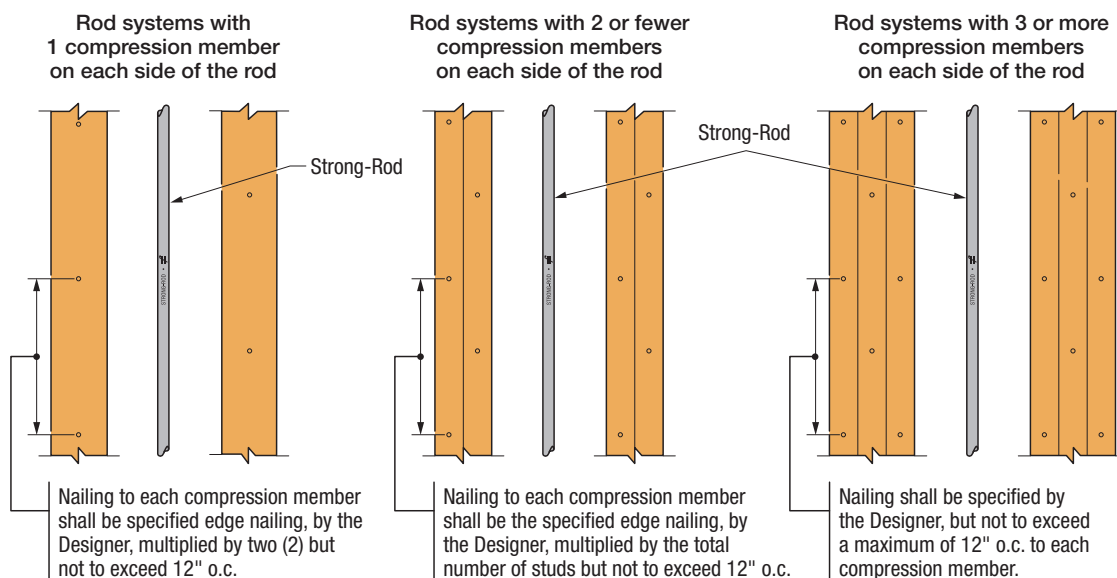

Moment Arm = center of rod to center of rod

Nailing Example: (4) total compression members: 2" o.c. edge nailing x 4 = 8" o.c. nailing at each compression member.

Strong-Rod™ ATS Components

G Compression Post Recommendations (cont.)

Symmetrical Compression Posts (Multiple 2x Members)
Perpendicular and Parallel to Grain Factored Resistance for D.Fir-L

Framing	Lumber (Each Side of ATS Rod)	Perpendicular to Grain, Q_r		Parallel to Grain Resistance, P_r lb. (kN)									
				Stud Height ft. [m]									
		lb.	kN	8	[2.44]	9	[2.74]	10	[3.05]	11	[3.35]	12	[3.66]
2x4 wall	1	14098	62.71	9481	42.17	7389	32.87	5799	25.80	4596	20.44	3682	16.38
	2	24813	110.37	18963	84.35	14779	65.74	11599	51.59	9192	40.89	7363	32.75
	3	33836	150.51	28444	126.52	22168	98.61	17398	77.39	13787	61.33	11045	49.13
	4	45114	200.68	37925	168.70	29557	131.48	23198	103.19	18383	81.77	14726	65.50
	5	56393	250.85	47407	210.87	36946	164.35	28997	128.98	22979	102.21	18408	81.88
	6	67671	301.02	56888	253.05	44336	197.21	34796	154.78	27575	122.66	22089	98.26
2x6 wall	1	22154	98.55	27886	124.04	24364	108.38	21102	93.87	18171	80.83	15597	69.38
	2	38992	173.44	55771	248.08	48728	216.75	42204	187.73	36342	161.66	31194	138.76
	3	53170	236.51	83657	372.12	73092	325.13	63307	281.60	54513	242.49	46792	208.14
	4	70894	315.35	111542	496.17	97456	433.51	84409	375.47	72684	323.32	62389	277.52
	5	88617	394.19	139428	620.21	121820	541.88	105511	469.34	90856	404.15	77986	346.90
	6	106341	473.03	167314	744.25	146184	650.26	126613	563.20	109027	484.97	93583	416.28
2x8 wall	1	30210	134.38	45449	124.04	42228	108.38	38942	93.87	35665	80.83	32464	69.38
	2	53170	236.51	90898	248.08	84455	216.75	77885	187.73	71330	161.66	64928	138.76
	3	72505	322.52	136347	372.12	126683	325.13	116827	281.60	106994	242.49	97393	208.14
	4	96673	430.02	181796	496.17	168910	433.51	155770	375.47	142659	323.32	129857	277.52
	5	120842	537.53	227245	620.21	211138	541.88	194712	469.34	178324	404.15	162321	346.90
	6	145010	645.04	272694	744.25	253365	650.26	233655	563.20	213989	484.97	194785	416.28

Lumber based on 2x_D.Fir-L No.1/No.2 grade. See General Notes for additional information.

Symmetrical Compression Posts (Multiple 2x Members)
Perpendicular and Parallel to Grain Factored Resistance for S-P-F

Framing	Lumber (Each Side of ATS Rod)	Perpendicular to Grain, Q_r		Parallel to Grain Resistance, P_r lb. (kN)									
				Stud Height ft. [m]									
		lb.	kN	8	[2.44]	9	[2.74]	10	[3.05]	11	[3.35]	12	[3.66]
2x4 wall	1	10674	47.48	8425	37.48	6626	29.47	5237	23.30	4173	18.56	3357	14.93
	2	18787	83.57	16851	74.96	13252	58.95	10474	46.59	8346	37.12	6714	29.86
	3	25618	113.96	25276	112.43	19877	88.42	15711	69.89	12518	55.68	10070	44.80
	4	34158	151.94	33702	149.91	26503	117.89	20948	93.18	16691	74.25	13427	59.73
	5	42697	189.93	42127	187.39	33129	147.37	26185	116.48	20864	92.81	16784	74.66
	6	51237	227.91	50553	224.87	39755	176.84	31422	139.77	25037	111.37	20141	89.59
2x6 wall	1	16774	74.61	23773	105.75	20965	93.26	18322	81.50	15909	70.77	13760	61.21
	2	29522	131.32	47546	211.50	41929	186.51	36644	163.00	31819	141.54	27519	122.41
	3	40258	179.07	71320	317.25	62894	279.77	54965	244.50	47728	212.31	41279	183.62
	4	53677	238.77	95093	422.99	83858	373.02	73287	326.00	63637	283.07	55038	244.82
	5	67096	298.46	118866	528.74	104823	466.28	91609	407.50	79547	353.84	68798	306.03
	6	80515	358.15	142639	634.49	125788	559.53	109931	489.00	95456	424.61	82557	367.23
2x8 wall	1	22874	101.75	37986	105.75	35494	93.26	32936	81.50	30361	70.77	27820	61.21
	2	40258	179.07	75972	211.50	70989	186.51	65872	163.00	60722	141.54	55640	122.41
	3	54897	244.19	113959	317.25	106483	279.77	98809	244.50	91083	212.31	83461	183.62
	4	73196	325.59	151945	422.99	141977	373.02	131745	326.00	121444	283.07	111281	244.82
	5	91495	406.99	189931	528.74	177471	466.28	164681	407.50	151805	353.84	139101	306.03
	6	109793	488.39	227917	634.49	212966	559.53	197617	489.00	182166	424.61	166921	367.23

Lumber based on 2x_S-P-F No.1/No.2 grade. See General Notes for additional information.

General Notes:

- Bearing loads are perpendicular to grain values and include bearing factor K_B and size factor K_{ZCP} .
- Perpendicular- and parallel to grain values include $K_D = 1.15$ load increase.
- Calculations based on $K_E = 1.0$ for parallel to grain resistance in depth direction of stud.
- Calculations assume $K_H = 1.10$ with wall sheathing providing lateral restraint against buckling in 38 mm direction of stud.
- Fastening of studs to wall sheathing and wall sheathing specifications to be provided by Design Professional, not by Simpson Strong-Tie.

Strong-Rod™ ATS Components

G Compression Post Recommendations (cont.)

Asymmetrical Posts: This arrangement means using a maximum of three built-up studs at the end of the wall and multiple number of studs at the opposite side of the Strong-Rod. This provides uniform anchor placement and consistent end-of-wall placement location at upper floor levels.

Asymmetrical Posts

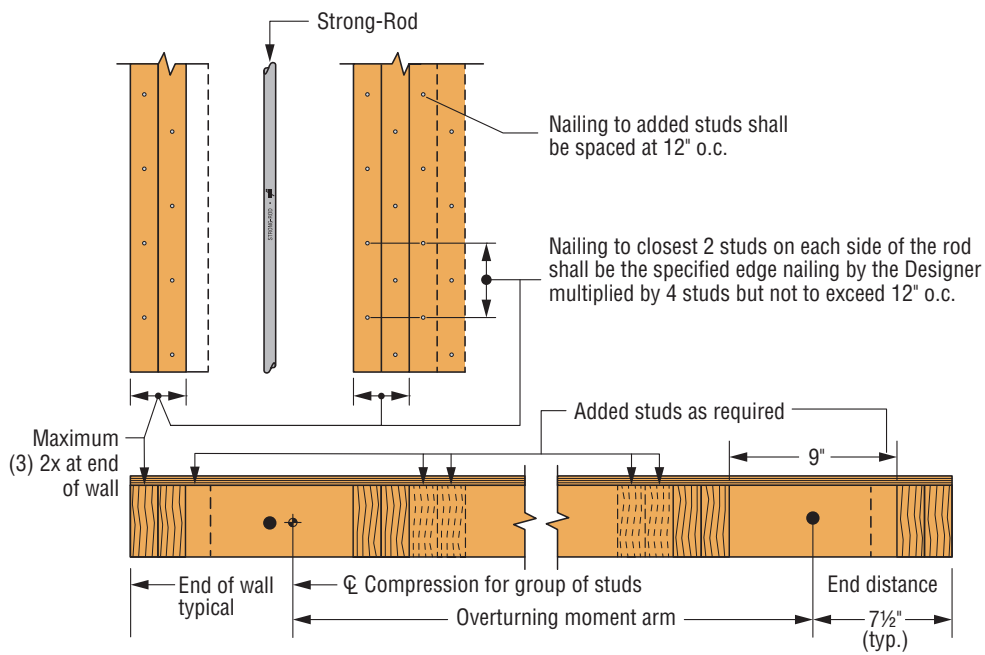

Estimate of Moment Arm = wall length - total no. of studs at the end of wall - rod space (9" max) - 3"

Nailing Example: (4) total closest compression members adjacent to rod: 2" o.c. edge nailing x 4 = 8" o.c. nailing to two closest studs, each side of rod.

Cavity Space (in.)	End Distance (in.)			
	(2) 2x End Member	(3) 2x End Member	4x End Member	6x End Member
6	6	7.5	6.5	8.5
9	7.5	9	8	10

Strong-Rod™ ATS Components

G Compression Post Recommendations (cont.)

Asymmetrical Compression Posts (Multiple 2x Members)
Perpendicular and Parallel to Grain Factored Resistance for D.Fir-L

Framing	Lumber (Each Side of ATS Rod)		Perpendicular to Grain, Q_r		Parallel to Grain Resistance, Pr lb. (kN)										COG from End	
	End Studs	Interior Studs	lb.	kN	Stud Height ft. [m]										in.	mm
					8	[2.44]	9	[2.74]	10	[3.05]	11	[3.35]	12	[3.66]		
2x4 wall	2	1	19456	86.54	14222	63.26	11084	49.30	8699	38.70	6894	30.66	5522	24.56	5.25	133.35
		2	24813	110.37	18963	84.35	14779	65.74	11599	51.59	9192	40.89	7363	32.75	7.50	190.50
		3	29324	130.44	23703	105.44	18473	82.17	14498	64.49	11489	51.11	9204	40.94	9.15	232.41
		4	34964	155.53	28444	126.52	22168	98.61	17398	77.39	13787	61.33	11045	49.13	10.50	266.70
		5	40603	180.61	33185	147.61	25862	115.04	20298	90.29	16085	71.55	12885	57.32	11.68	296.64
		6	46242	205.70	37925	168.70	29557	131.48	23198	103.19	18383	81.77	14726	65.50	12.75	323.85
	3	1	23967	106.61	18963	84.35	14779	65.74	11599	51.59	9192	40.89	7363	32.75	5.25	133.35
		2	29324	130.44	23703	105.44	18473	82.17	14498	64.49	11489	51.11	9204	40.94	7.35	186.69
		3	33836	150.51	28444	126.52	22168	98.61	17398	77.39	13787	61.33	11045	49.13	9.00	228.60
		4	39475	175.59	33185	147.61	25862	115.04	20298	90.29	16085	71.55	12885	57.32	10.39	263.98
		5	45114	200.68	37925	168.70	29557	131.48	23198	103.19	18383	81.77	14726	65.50	11.63	295.28
		6	50754	225.76	42666	189.79	33252	147.91	26097	116.09	20681	91.99	16567	73.69	12.75	323.85
2x6 wall	2	1	30573	136.00	41828	186.06	36546	162.56	31653	140.80	27257	121.24	23396	104.07	5.25	133.35
		2	38992	173.44	55771	248.08	48728	216.75	42204	187.73	36342	161.66	31194	138.76	7.50	190.50
		3	46081	204.98	69714	310.10	60910	270.94	52756	234.67	45428	202.07	38993	173.45	9.15	232.41
		4	54943	244.40	83657	372.12	73092	325.13	63307	281.60	54513	242.49	46792	208.14	10.50	266.70
		5	63804	283.82	97600	434.14	85274	379.32	73858	328.54	63599	282.90	54590	242.83	11.68	296.64
		6	72666	323.24	111542	496.17	97456	433.51	84409	375.47	72684	323.32	62389	277.52	12.75	323.85
	3	1	42979	191.18	55771	248.08	48728	216.75	42204	187.73	36342	161.66	31194	138.76	5.25	133.35
		2	48740	216.80	69714	310.10	60910	270.94	52756	234.67	45428	202.07	38993	173.45	7.35	186.69
		3	53170	236.51	83657	372.12	73092	325.13	63307	281.60	54513	242.49	46792	208.14	9.00	228.60
		4	62032	275.93	97600	434.14	85274	379.32	73858	328.54	63599	282.90	54590	242.83	10.39	263.98
		5	70894	315.35	111542	496.17	97456	433.51	84409	375.47	72684	323.32	62389	277.52	11.63	295.28
		6	79756	354.77	125485	558.19	109638	487.69	94960	422.40	81770	363.73	70188	312.21	12.75	323.85
2x8 wall	2	1	41690	185.45	68173	186.06	63341	162.56	58414	140.80	53497	121.24	48696	104.07	5.25	133.35
		2	53170	236.51	90898	248.08	84455	216.75	77885	187.73	71330	161.66	64928	138.76	7.50	190.50
		3	62838	279.52	113622	310.10	105569	270.94	97356	234.67	89162	202.07	81160	173.45	9.15	232.41
		4	74922	333.27	136347	372.12	126683	325.13	116827	281.60	106994	242.49	97393	208.14	10.50	266.70
		5	87006	387.02	159071	434.14	147796	379.32	136299	328.54	124827	282.90	113625	242.83	11.68	296.64
		6	99090	440.78	181796	496.17	168910	433.51	155770	375.47	142659	323.32	129857	277.52	12.75	323.85
	3	1	58608	260.70	90898	248.08	84455	216.75	77885	187.73	71330	161.66	64928	138.76	5.25	133.35
		2	66463	295.64	113622	310.10	105569	270.94	97356	234.67	89162	202.07	81160	173.45	7.35	186.69
		3	72505	322.52	136347	372.12	126683	325.13	116827	281.60	106994	242.49	97393	208.14	9.00	228.60
		4	84589	376.27	159071	434.14	147796	379.32	136299	328.54	124827	282.90	113625	242.83	10.39	263.98
		5	96673	430.02	181796	496.17	168910	433.51	155770	375.47	142659	323.32	129857	277.52	11.63	295.28
		6	108758	483.78	204520	558.19	190024	487.69	175241	422.40	160492	363.73	146089	312.21	12.75	323.85

1. Lumber based on 2x_ D.Fir-L No.1/No.2 grade. See General Notes for additional information.
2. COG = Centre of Gravity of Compression End

General Notes:

- Bearing loads are perpendicular-to-grain values and include bearing factor K_B and size factor K_{ZCP} .
- Perpendicular- and parallel-to-grain values include $K_D = 1.15$ load increase.
- Calculations based on $K_E = 1.0$ for parallel-to-grain resistance in depth direction of stud.
- Calculations assume $K_H = 1.10$ with wall sheathing providing lateral restraint against buckling in 38 mm direction of stud.
- Fastening of studs to wall sheathing and wall sheathing specifications to be provided by Design Professional, not by Simpson Strong-Tie.

Compression Post Recommendations (cont.)

Asymmetrical Compression Posts (Multiple 2x Members)
Perpendicular and Parallel to Grain Factored Resistance for S-P-F

Framing	Lumber (Each Side of ATS Rod)		Perpendicular to Grain, Q_r		Parallel to Grain Resistance, Pr lb. (kN)										COG from End	
	End Studs	Interior Studs	lb.	kN	Stud Height ft. [m]										in.	mm
					8	[2.44]	9	[2.74]	10	[3.05]	11	[3.35]	12	[3.66]		
2x4 wall	2	1	14731	65.53	12638	56.22	9939	44.21	7855	34.94	6259	27.84	5035	22.40	5.25	133.35
		2	18787	83.57	16851	74.96	13252	58.95	10474	46.59	8346	37.12	6714	29.86	7.50	190.50
		3	22203	98.76	21064	93.70	16565	73.68	13092	58.24	10432	46.40	8392	37.33	9.15	232.41
		4	26472	117.76	25276	112.43	19877	88.42	15711	69.89	12518	55.68	10070	44.80	10.50	266.70
		5	30742	136.75	29489	131.17	23190	103.16	18329	81.53	14605	64.96	11749	52.26	11.68	296.64
		6	35012	155.74	33702	149.91	26503	117.89	20948	93.18	16691	74.25	13427	59.73	12.75	323.85
	3	1	18146	80.72	16851	74.96	13252	58.95	10474	46.59	8346	37.12	6714	29.86	5.25	133.35
		2	22203	98.76	21064	93.70	16565	73.68	13092	58.24	10432	46.40	8392	37.33	7.35	186.69
		3	25618	113.96	25276	112.43	19877	88.42	15711	69.89	12518	55.68	10070	44.80	9.00	228.60
		4	29888	132.95	29489	131.17	23190	103.16	18329	81.53	14605	64.96	11749	52.26	10.39	263.98
		5	34158	151.94	33702	149.91	26503	117.89	20948	93.18	16691	74.25	13427	59.73	11.63	295.28
		6	38428	170.93	37914	168.65	29816	132.63	23566	104.83	18777	83.53	15106	67.19	12.75	323.85
2x6 wall	2	1	23148	102.97	35660	158.62	31447	139.88	27483	122.25	23864	106.15	20639	91.81	5.25	133.35
		2	29522	131.32	47546	211.50	41929	186.51	36644	163.00	31819	141.54	27519	122.41	7.50	190.50
		3	34890	155.20	59433	264.37	52412	233.14	45804	203.75	39773	176.92	34399	153.01	9.15	232.41
		4	41600	185.04	71320	317.25	62894	279.77	54965	244.50	47728	212.31	41279	183.62	10.50	266.70
		5	48309	214.89	83206	370.12	73376	326.39	64126	285.25	55683	247.69	48158	214.22	11.68	296.64
		6	55019	244.74	95093	422.99	83858	373.02	73287	326.00	63637	283.07	55038	244.82	12.75	323.85
	3	1	28516	126.84	47546	211.50	41929	186.51	36644	163.00	31819	141.54	27519	122.41	5.25	133.35
		2	34890	155.20	59433	264.37	52412	233.14	45804	203.75	39773	176.92	34399	153.01	7.35	186.69
		3	40258	179.07	71320	317.25	62894	279.77	54965	244.50	47728	212.31	41279	183.62	9.00	228.60
		4	46967	208.92	83206	370.12	73376	326.39	64126	285.25	55683	247.69	48158	214.22	10.39	263.98
		5	53677	238.77	95093	422.99	83858	373.02	73287	326.00	63637	283.07	55038	244.82	11.63	295.28
		6	60386	268.61	106980	475.87	94341	419.65	82448	366.75	71592	318.46	61918	275.42	12.75	323.85
2x8 wall	2	1	31566	140.41	56979	158.62	53241	139.88	49404	122.25	45541	106.15	41730	91.81	5.25	133.35
		2	40258	179.07	75972	211.50	70989	186.51	65872	163.00	60722	141.54	55640	122.41	7.50	190.50
		3	47577	211.63	94966	264.37	88736	233.14	82341	203.75	75902	176.92	69550	153.01	9.15	232.41
		4	56727	252.33	113959	317.25	106483	279.77	98809	244.50	91083	212.31	83461	183.62	10.50	266.70
		5	65876	293.03	132952	370.12	124230	326.39	115277	285.25	106263	247.69	97371	214.22	11.68	296.64
		6	75026	333.73	151945	422.99	141977	373.02	131745	326.00	121444	283.07	111281	244.82	12.75	323.85
	3	1	38885	172.97	75972	211.50	70989	186.51	65872	163.00	60722	141.54	55640	122.41	5.25	133.35
		2	47577	211.63	94966	264.37	88736	233.14	82341	203.75	75902	176.92	69550	153.01	7.35	186.69
		3	54897	244.19	113959	317.25	106483	279.77	98809	244.50	91083	212.31	83461	183.62	9.00	228.60
		4	64046	284.89	132952	370.12	124230	326.39	115277	285.25	106263	247.69	97371	214.22	10.39	263.98
		5	73196	325.59	151945	422.99	141977	373.02	131745	326.00	121444	283.07	111281	244.82	11.63	295.28
		6	82345	366.29	170938	475.87	159724	419.65	148213	366.75	136624	318.46	125191	275.42	12.75	323.85

1. Lumber based on 2x S-P-F No. 1/No. 2 grade. See General Notes for additional information.
2. COG = Centre of Gravity of Compression End

General Notes:

- Bearing loads are perpendicular-to-grain values and include bearing factor K_B and size factor K_{ZCP} .
- Perpendicular- and parallel-to-grain values include $K_D = 1.15$ load increase.
- Calculations based on $K_e = 1.0$ for parallel-to-grain resistance in depth direction of stud.
- Calculations assume $K_H = 1.10$ with wall sheathing providing lateral restraint against buckling in 38 mm direction of stud.
- Fastening of studs to wall sheathing and wall sheathing specifications to be provided by Design Professional, not by Simpson Strong-Tie.

Strong-Rod™ ATS Components

Top-Storey Termination Types

Three top-storey run termination options are provided to tailor the solution to the project's specific needs. The option chosen will depend on construction preference or structure conditions, such as sloped top plates, truss/rafter locations that may conflict with top-plate termination and available space above top plates for the take-up device assembly.

The traditional termination is the top-plate termination. However, run stops below the top plate using the bridge block or strap detail are often necessary or preferred. The bridge block detail accommodates high loads with installation from the inside of the structure. Where loads are lower and straps are preferred, the strap detail can be used. With the design support services we offer, Simpson Strong-Tie will also verify each specified run application and recommend the best termination method for the given project. Consider these variables when specifying run terminations.

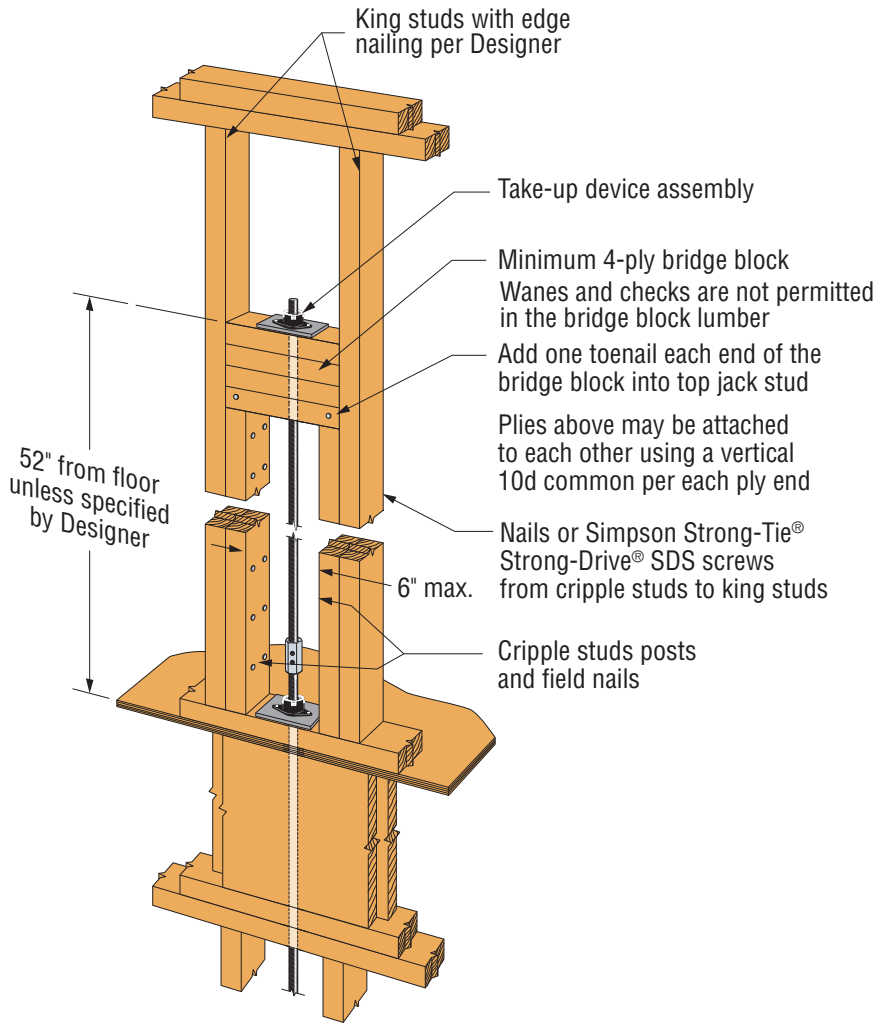
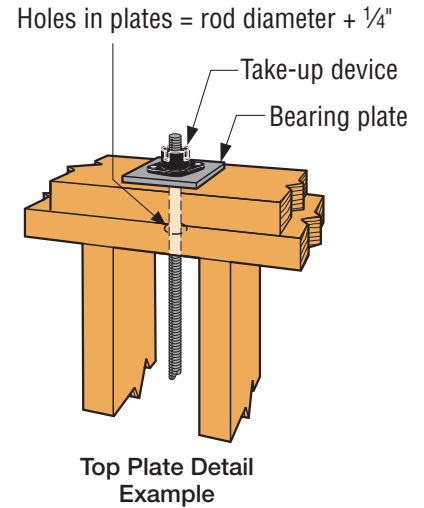

Bridge Block Detail Example

Strong-Rod™ ATS Components

Top-Storey Termination Types (cont.)

Cripple Wall Studs Below Bridge Block for D.Fir-L

Number of Cripple Studs Below Bridge Block	2x4 Wall				2x6 Wall			
	Factored Resistance		Fastening Cripple to King Stud (Per Side of Rod)		Factored Resistance		Fastening Cripple to King Stud (Per Side of Rod)	
	lb.	kN	Nails	SDS Screws	lb.	kN	Nails	SDS Screws
1 cripple ea. side of rod	9355	41.61	(17) 16d	—	11500	51.16	(20) 16d	(14) SDS22300
2 cripples ea. side of rod	13115	58.34	(23) 16d ⁸	—	16785	74.67	(29) 16d ⁸	(16) SDS22412

Cripple Wall Studs Below Bridge Block for SPF

Number of Cripple Studs Below Bridge Block	2x4 Wall				2x6 Wall			
	Factored Resistance		Fastening Cripple to King Stud (Per Side of Rod)		Factored Resistance		Fastening Cripple to King Stud (Per Side of Rod)	
	lb.	kN	Nails	SDS Screws	lb.	kN	Nails	SDS Screws
1 cripple ea. side of rod	7080	31.49	(14) 16d	(10) SDS22300	8710	38.75	(17) 16d	(12) SDS22300
2 cripples ea. side of rod	9930	44.17	(20) 16d ⁸	(11) SDS22412	12705	56.52	(25) 16d ⁸	(14) SDS22412

- Capacities shown are based on perpendicular to grain values bearing below the bridge block.
- Fastening is limited to worse case capacity shown.
- Capacity has been increased by 15% for short term loading. No further increase is allowed.
- Assume boundary nailing does not contribute to the system capacity.
- Adjust fastening for other loading conditions and fastener types.
- Minimum spacing, end and edge distances shall be in accordance with 12.9.2.1 (nails) and 12.11.2.2 (Screws assuming screw diameter = 0.25") of CSA O86-14.

- Bridge block by designers. Bridge block member size and species may further limit this capacity.
- Cripple studs shall be nailed to full-height studs per evaluation drawings and details above. If (2) cripples are required on each side of rod, nail cripple adjacent to full-height stud with scheduled nails and nail inner cripple with 1/2 of the scheduled nails. If (3) cripples are required on each side of the rod, nail cripple adjacent to full-height stud with scheduled nails and the middle cripple with 2/3 of the scheduled nails and the innermost cripple with 1/3 of the scheduled nails.

Strong-Rod™ ATS Components

Top-Storey Termination Types (cont.)

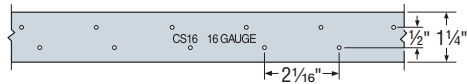

CS16 Hole Pattern
(all other CS straps similar)

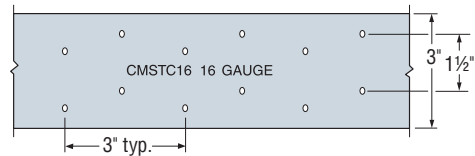

CMSTC16 Hole Pattern

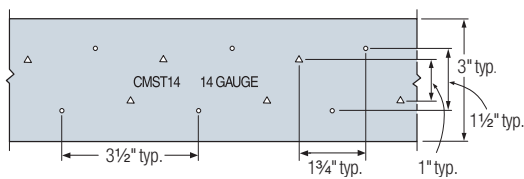

CMST14 and CMST12 Hole Pattern

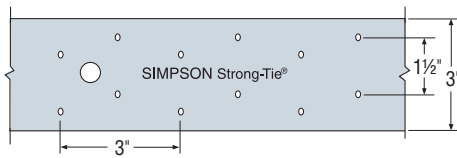

MSTC52 Hole Pattern
(MSTC 40 similar)

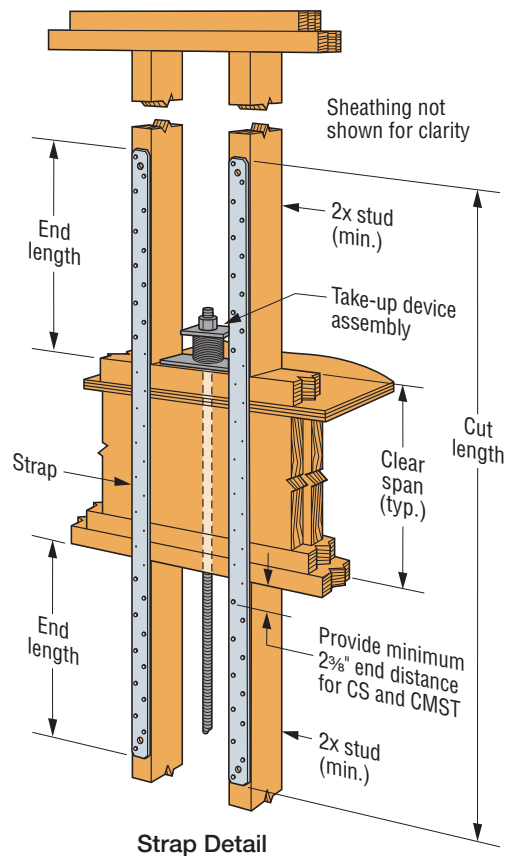

Strap Detail

Strap Model No.	Ga.	Width (in.)	Minimum Studs Required	End Length (in.)	Cut Length or Actual Length (in.)	Fasteners per Strap	Factored Tensile Resistance	
							D.Fir-L (K _D = 1.15)	S-P-F (K _D = 1.15)
							lb.	lb.
2-CS16	16	1 1/4	2x	14	Clear Span + 28	(24) 8d	4610	4610
							20.51	20.51
2-MSTC40	16	3	(2) 2x	11	40 1/4	(24) 10d	6820	6230
							30.34	27.72
							11370	10390
2-MSTC52	16	3	(2) 2x	17	52 1/4	(40) 10d	50.58	46.22
							11690	11690
2-CMSTC16	16	3	(2) 2x	20	Clear Span + 40	(46) 10d	52.00	52.00
							16860	16860
2-CMST14	14	3	(2) 2x	31	Clear Span + 62	(66) 10d	75.00	75.00

1. Factored resistances shown are the lesser of the steel tensile strength (T_r) or the lateral nail values (N_r) for two straps.
2. Use half of the required nails in each member being connected to achieve the listed capacities.
3. See current *Wood Construction Connectors – Canadian Limit States Design* catalogue for other strap configurations.
4. Values shown are for short-term load durations ($K_D = 1.15$) only.
5. A maximum clear span of 18" is permitted for MSTC40 and MSTC52.
6. Nails: 8d = 0.131" dia. x 2 1/2" long. 10d = 0.148" dia. x 3" long.

Rod System Design Considerations for Shearwall Overturning Restraint

When specifying Simpson Strong-Tie® Strong-Rod™ Systems for shearwall overturning restraint, one should weigh several factors to ensure that the system is configured to meet the design intent and building codes. These factors apply to each method of specification. The list on the left below delineates the general design requirements for any continuous rod tiedown system used to restrain overturning forces in stacked shearwalls. The list on the right provides a description of how our system is designed and of the services we provide in order to meet the general strength and performance requirements.

General Shearwall Overturning Restraint Rod System

Designer Responsibilities

- Calculating lateral forces in each diaphragm (roof and floor) of structure
- Locating shearwalls in each level of the structure
- Calculating cumulative overturning tension and compression forces for each shearwall
- Design and specification of compression posts
- Design and specification of anchorage to foundation including anchor bolt diameter and grade of steel

Information Required to Design Rod Tiedown System

- Building code edition
- Building jurisdiction deformation requirements, (if applicable) such as rod elongation and system deformation limits
- Cumulative overturning tension/compression forces
- Estimate of wood shrinkage per level
- Wood framing including size and species of stud, post, sill and sole plates as well as floor system type and depth
- Wall height (finish floor to ceiling)
- Anchor bolt size and grade at foundation
- Anchor bolt coating
- Run start above foundation such as steel or wood beam
- Run termination preference at top of run (top plate, bridge block, strap)
- Floor plan shearwall layout

Required Rod System Design Checks

- Tensile capacity of rod
- Bearing plate capacity
- Travel capacity of shrinkage take-up device
- Load capacity of shrinkage take-up device
- Rod elongation per level using net tensile area of rod
- Total system deformation per level
- Verification that rod elongation plus take-up device displacement is less than or equal to 0.30" or 7.6 mm. This total vertical displacement limit may be exceeded if it can be demonstrated that the shearwall drift limit and deformation compatibility are met when accounting for all sources of vertical displacements.

Strong-Rod™ Design Checklist

Rod Tension (Overturning) Check

- Rods at each level are selected to meet the cumulative overturning tension force per level as delivered from bearing plates and transfer it to the foundation
- Standard and high-strength steel rods are designed to meet the requirements of CSA S16-14
 - a. Standard-strength Strong-Rod based on 43/58 ksi (F_Y/F_U)
 - b. High-strength Strong-Rod based on 92/120 ksi (F_Y/F_U)
 - c. H150 Strong-Rod based on 130/150 ksi (F_Y/F_U)
- Rod elongation limits (see below)

Bearing Plate Check

- Bearing plates designed to transfer incremental overturning force per level into the rod
- Bearing stress on wood member limited in accordance with the CSA 086-14 to provide proper bearing capacity and limit wood crushing
- Bearing plate thickness has been sized to limit plate bending in order to provide full bearing on wood member

Shrinkage Take-up Device Check

- Shrinkage take-up device is selected to accommodate estimated wood shrinkage to eliminate gaps in the system load path
- Load capacity of the take-up device compared with incremental overturning force to ensure that load is transferred into rod

Movement/Deflection Check

- System deformation is an integral design component impacting the selection of rods, bearing plates and shrinkage take-up devices
- Rod elongation plus take-up device displacement is limited to a maximum of 0.30 inch or 7.6 mm per level or as further limited by the requirements of the engineer or the governing authority having jurisdiction
- Total system deformation reported for use in d_a term (total vertical elongation of wall anchorage system) when calculating shearwall deflection
- Both seating increment (Δ_R) and deflection at factored resistance (Δ_F) are included in the overall system movement.

Specifying Rod Systems for Shearwall Overturning Restraint

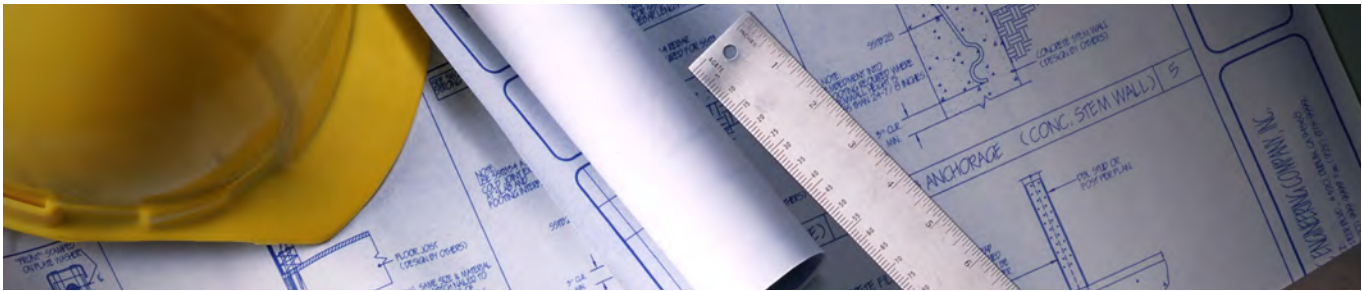

Methods for Specifying

We recognize that specifying the Simpson Strong-Tie Strong-Rod™ Anchor Tiedown System (ATS) for shearwall overturning restraint is unlike choosing any other product we offer. You must first address several design questions and considerations to ensure that the system will be configured to meet the design's intent. For example, when determining whether to use Strong-Rod Systems or conventional holdowns and strapping, a Designer must determine the project's incremental and cumulative loads or specification of elongation and system deflection limits. The Designer will need to determine the compression posts, sheathing thickness and grade, nailing schedule, horizontal drift, and meet all other requirements in accordance with the applicable building code.

For more on these issues and many others, please visit strongtie.com. We currently offer the following two methods of specifying:

Specify Pre-Engineered Runs

The catalogue provides Designers with pre-engineered ATS runs, which can be specified in the construction documents with associated details. The Designer will be required to determine the overturning tension force at each level and choose the pre-engineered run from the tables within this catalogue based on the number of floors and the necessary capacity. See p. 39 for a design example, and pp. 42–71 for the full list of pre-engineered runs.

Handling Deferred Submittals

The Designer may also choose to provide general specifications and loads in the construction documents and require the contractor to submit deferred design calculations and shop drawings. The Designer can download generic specifications and notes to place in the construction documents at strongtie.com/srs. Generic details can also be obtained to insert into the Designer's construction documents.

Some of the items required to be included in the Designer's construction document are:

- System elongation limits at each level
- Cumulative tension and compression loads at each level
- Anchor diameter
- Details of system run start and termination
- General Notes for rod system design

Specify Pre-Engineered Runs

The following is an example of how pre-engineered runs are specified from this catalogue.

The Designer shall determine the cumulative overturning tension and compression forces at each floor. The ATS components (Strong-Rod™ threaded rod and bearing plates) are selected on the basis of the factored tension forces. The designer should then select the lumber at the ends of the shearwall on the basis of the factored forces. Note that the compression forces are typically greater than the tension forces due to combinations of additional forces such as dead and live load.

Simpson Strong-Tie® Anchor Tiedown System component capacities are selected to meet or exceed the design forces provided and determined by the Designer. Simpson Strong-Tie has not confirmed and is not responsible for any of the design, engineering, calculations or derivation of the structural forces related to the building.

The Designer is responsible for evaluating the effects of lumber shrinkage and ATS elongation on shearwall drift. Please refer to p. 13 for information regarding shearwall drift.

For simplicity of the design and installation, it is recommended that the Designer group similar runs together.

Given: NBCC 2015

- Wall geometry and shear forces as shown in Figure 1 below
- Douglas Fir-Larch wall plates
- 2x4 nominal wall thickness
- 0.30 m floor thickness

Step 1

Determine the cumulative overturning and incremental forces based on the applied storey shear:

The moment arm is the distance between the centerline of compression members and centerline of tension members. For symmetrical post configurations, this is typically the distance between tension rods on each end of the shearwall. For tension loads, gravity loads have not been included.

$$T_3 = \text{Cumulative OT Tension L3} = \frac{15(3)}{3.66} = 12.30\text{kN}$$

$$T_2 = \text{Cumulative OT Tension L2} = \frac{15(6) + 12.5(3)}{3.66} = 34.84\text{kN}$$

$$T_1 = \text{Cumulative OT Tension L1} = \frac{15(9) + 12.5(6) + 3(10)}{3.66} = 65.57\text{kN}$$

Determine the incremental overturning forces at each level. These are typically the difference in the cumulative forces at the stories above and below. These forces are generated at each level, and are transferred into the rod by the bearing plate and nut.

Incremental OT Force roof = 12.30kN
 Incremental OT Force L3 = 34.84 – 12.3 = 22.54kN
 Incremental OT Force L2 = 65.57 – 34.84 = 30.73kN

Figure 2 below shows the load path at level 2.

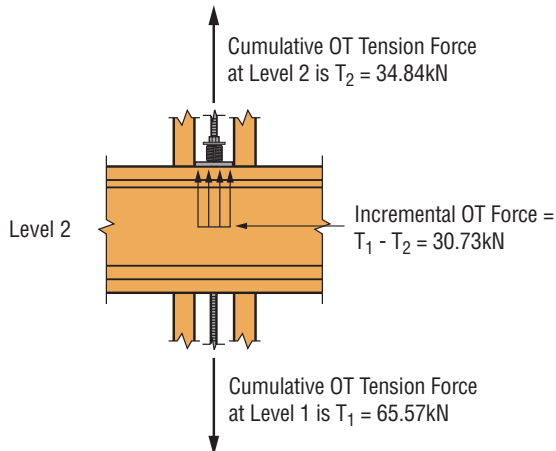

Figure 2

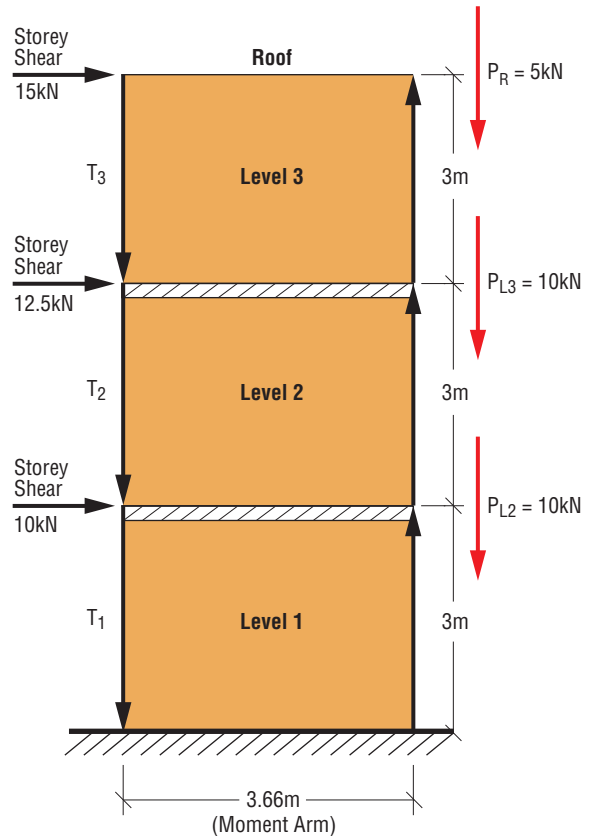

Figure 1

Determine the cumulative compression forces in the studs at the end of the shearwalls.

P = Forces due to gravity loads.

Cumulative OT Compression L1 = $T_1 + 5 + 10 + 10 = 90.57\text{ kN}$
 Cumulative OT Compression L2 = $T_2 + 5 + 10 = 49.84\text{ kN}$
 Cumulative OT Compression L3 = $T_3 + 5 = 17.30\text{ kN}$

Strong-Rod™ ATS Methods of Specifying

Specify Pre-Engineered Runs (cont.)

Step 2

Select system and verify tension capacities

Try: TDS3-7/8 (see p. 46)

Storey	Load Component	Capacity (kN)	Factored Load (kN)	
3rd Floor	Factored Tensile Resistance, Tr	42.45	12.30	o.k.
	Incremental Bearing Resistance	76.15	22.54	
2nd Floor	Factored Tensile Resistance, Tr	79.98	34.84	o.k.
	Incremental Bearing Resistance	76.15	30.73	
1st Floor	Factored Tensile Resistance, Tr	79.98	65.57	o.k.

Step 3

Select compression members (see pp. 29–33)

Storey	Cumulative OT Compression Force (kN)	Req. Studs Each Side of ATS Rod	2 x 4 x 2.74 m D.Fir-L Stud Compression Capacity (kN)	
3rd Floor	17.30	(1) 2x4	32.87	o.k.
2nd Floor	49.84	(2) 2x4	65.74	
1st Floor	90.57	(3) 2x4	98.61	

For the top floor, assume Designer opts to use bridge block termination with a single 2x4 cripple stud and a single 2x4 king stud on either side.

Step 4

Determine the nailing requirement for shear transfer from the cripple stud to the king stud.

Assume 16d common nails (0.162" dia. x 3½"), side-member thickness of 38.1 mm (1½"), main-member penetration of 38.1 mm (1½"), D.Fir-L members, and short-term loading ($K_D = 1.15$)

Factored lateral resistance of each nail is 1.29 kN (290 lb.) as per CSA 086-14 Clause 12.9.4

Compressive force in each cripple = $12.30 / 2 = 6.15$ kN

Number of nails required = $(6.15 \text{ kN}) / (1.29 \text{ kN} / \text{nail}) =$ five 16d common nails for each cripple stud to king stud

Alternatively, Simpson Strong-Tie® SDWS screws can be used for shear transfer when more than one cripple stud per wall cavity side is required:

Assume SDWS22400DB (0.22" x 4") screws or otherwise the same conditions as above

Factored lateral resistance of each screw is 1.73 kN (390 lb.) as per F-SDWSSDWH flir

Number of screws required = $(6.15 \text{ kN}) / (1.73 \text{ kN} / \text{screw}) =$ four SDWS22400DB screws for each cripple stud to king stud

For worst-case scenarios (where compressive load nears compressive resistance of studs), see p. 34.

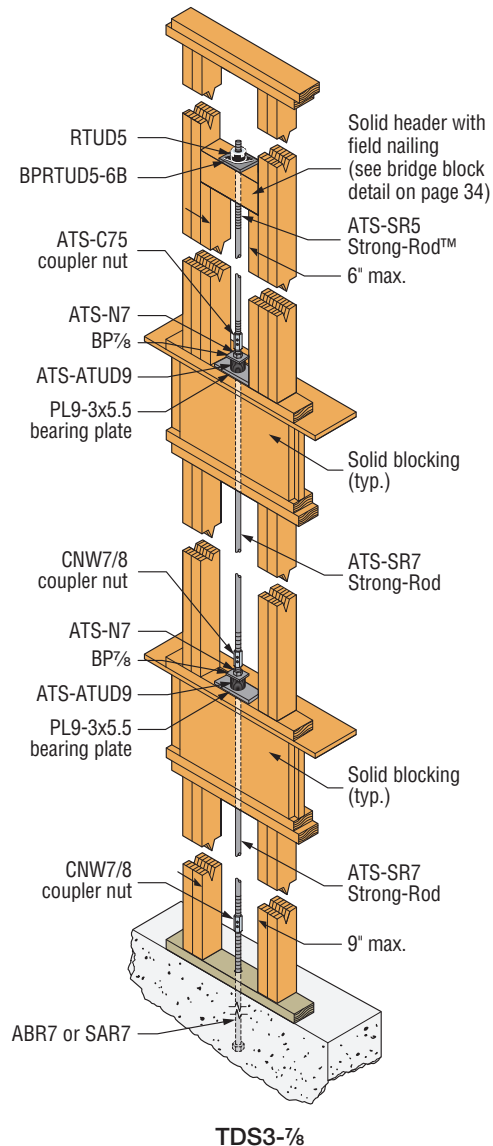

Step 5

Total vertical displacement of each storey, or between restraints, meets the total vertical displacement limit of 0.30" or 7.6 mm because the pre-engineered run TDS3-7/8 uses regular-strength rod. As discussed on p.13, the prescriptive limit can be waived if the building design conforms to the calculation procedures in CSA 086-14 *Engineering Design in Wood* (Clause 11.7.1), *APEGBC Technical and Practice Bulletin*, or the *Mid-Rise Wood-Frame Construction Handbook* Special Publication SP-57E by FPIInnovations.

Handling Deferred Submittals

A continuous rod tiedown system is an ideal shearwall restraint system for multi-storey light-frame wood construction. If your firm prefers these systems to be included in a deferred submittal process, there are some elements to your specification that merit consideration to ensure the proper performance of the structure being designed.

These Documents Should Include:

1. Floor heights and depths need to be clearly shown on the construction documents.
2. Wall heights from bottom of sill/sole plates to top of double top plates need to be clearly indicated.
3. A summary of cumulative tensile and compressive forces for each wall that will be utilizing the continuous rod tiedown system.
4. Maximum total deflection of each continuous rod tiedown system at each level needs to be specified on the construction document.
5. Bearing plates shall be designed for bending.
6. General Notes for continuous rod tiedown system design similar to the following.

Sample Specification

The following represents some General Notes that should be added to your construction documents in a deferred submittal.

Continuous Rod Tiedown System

1. The continuous rod tiedown system shall be Simpson Strong-Tie® Strong-Rod™ Anchor Tiedown System for shearwall overturning restraint.
2. In a multi-storey shearwall installation, the continuous rod tiedown system shall be restrained by bearing plates at each storey of the multi-storey shearwall. Shrinkage compensating devices shall be provided at each restraint location.
3. Skipping storeys, where bearing plates are omitted at intermediate floors that result in multiple storeys being tied together, is prohibited.
4. Unless shown otherwise on the structural plans, the computed maximum vertical travel (elongation or stretch) between restraint locations, together with computed deformations of shrinkage compensating device, within any storey short-term duration loading, such as wind or earthquake loads, shall not exceed 0.30", or 7.6 mm, or as specified. Rod elongation or stretch shall be computed as the product PL/AE , where P is the axial load (lb.), L is the initial rod length between restraints at the storey under consideration (inches), E is 29,000,000 (psi) and A is the net tensile area of the rod (in²). Device displacement shall be as specified in the evaluation report including $\Delta_R + \Delta_F (P_D/P_R)$.
5. Calculations and shop drawings meeting all the above requirements shall be submitted and provided by the manufacturer of the continuous rod tiedown system for review and approval prior to installation.
6. Drawings provided by the manufacturer shall specify the proprietary components or systems.
7. Simpson Strong-Tie wood connectors are specifically required to meet the structural calculations of the plan. Before substituting another brand, confirm load capacity based on reliable published testing data or calculations. The Engineer/Designer of Record should evaluate and give written approval for substitution prior to installation.



Go to strongtie.com/srs to download master specifications, general notes and typical details to be placed within your construction documents or specifications.

Strong-Rod™ ATS Pre-Engineered Runs

One-Storey Systems

ATS System		TDS1-5/8		TDS1-3/4		TDS1-7/8		
1st Floor	Plates/Studs	D.Fir-L	S-P-F	D.Fir-L	S-P-F	D.Fir-L	S-P-F	
	Factored Tensile Resistance, T_r	lb.	8780	8780	12980	12980	17955	17955
		kN	39.11	39.11	57.82	57.82	79.98	79.98
8' Posts	2x4 framing	(1) 2x4 each side	(2) 2x4 each side	(2) 2x4 each side	(2) 2x4 each side	(2) 2x4 each side	(3) 2x4 each side	
	2x6 framing	(1) 2x6 each side	(1) 2x6 each side	(1) 2x6 each side	(1) 2x6 each side	(1) 2x6 each side	(2) 2x6 each side	

1. Unless specifically requested, anchor bolts are not included in the system runs.
2. Post design is based on the tension capacity of the system. The Designer is responsible for verifying that the wood posts are capable of resisting all required load combinations.
3. Total vertical displacement of each storey, or between restraints, meets the 0.300" (7.6 mm) for regular-strength Strong-Rod runs. High-strength Strong-Rod runs exceed the total vertical displacement limit of 0.300" (7.6 mm) for each storey. The total vertical displacement limit may be exceeded if it can be demonstrated that the shearwall drift limit and deformation compatibility are met when accounting for all sources of vertical displacements. Total vertical

displacement of the individual pre-engineered runs assumes 6" rod length at the top storey and 8" rod length plus 14" floor depth (including wall plates) for all other storeys.

4. See design example on p. 39 for use of these tables.
5. Designer is responsible for verifying that the cumulative tension demand forces do not exceed the factored tensile resistance shown. See Step 2 in design example on p. 40.
6. System capacity assumes top plate termination. See p. 34 for details. For bridge block termination, reduce top storey capacity according to cripple wall studs load table on p. 35.

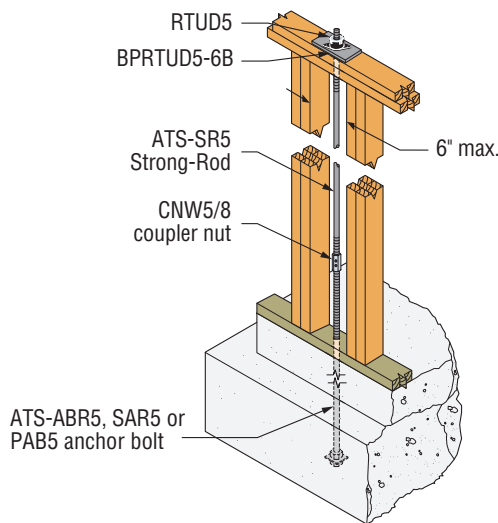

TDS1-5/8

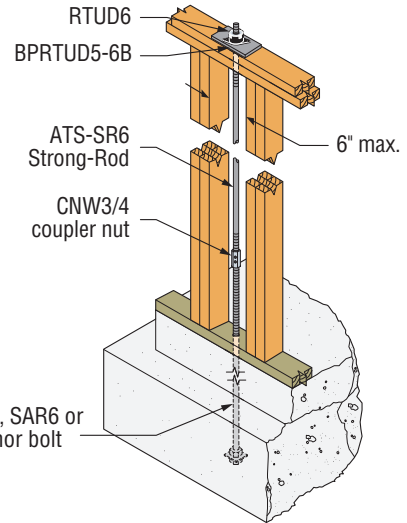

TDS1-3/4

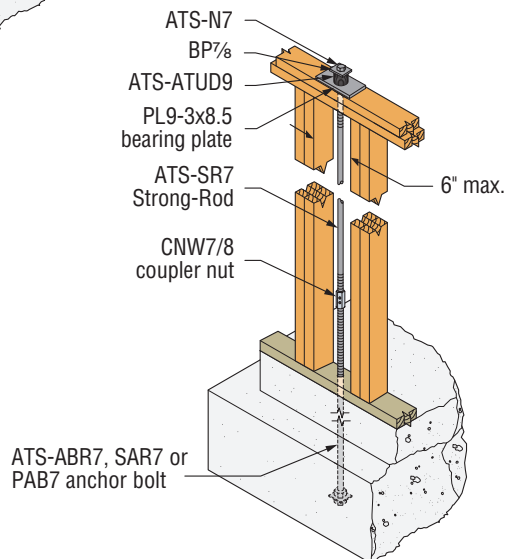

TDS1-7/8

Anchorage-to-concrete and foundation design by Designer. For bridge block termination, reduce top-storey capacity as per p. 35.

Strong-Rod™ ATS Methods of Specifying

One-Storey Systems (cont.)

ATS System		TDS1-1		TDS1-1½		
1st Floor	Plates/Studs		D.Fir-L	S-P-F	D.Fir-L	S-P-F
	Factored Tensile Resistance, T_r	lb.	18670	18670	18670	18670
		kN	83.16	83.16	83.16	83.16
8' Posts	2x4 framing	(2) 2x4 each side	(3) 2x4 each side	(2) 2x4 each side	(3) 2x4 each side	
	2x6 framing	(2) 2x6 each side	(2) 2x6 each side	(2) 2x6 each side	(2) 2x6 each side	

1. Unless specifically requested, anchor bolts are not included in the system runs.
2. Post design is based on the tension capacity of the system. The Designer is responsible for verifying that the wood posts are capable of resisting all required load combinations.
3. Total vertical displacement of each storey, or between restraints, meets the 0.300" (7.6 mm) for regular-strength Strong-Rod runs. High-strength Strong-Rod runs exceed the total vertical displacement limit of 0.300" (7.6 mm) for each storey. The total vertical displacement limit may be exceeded if it can be demonstrated that the shearwall drift limit and deformation compatibility are met when accounting for all sources of vertical displacements. Total vertical displacement of the individual pre-engineered runs assumes 6' rod length at the top storey and 8' rod length plus 14" floor depth (including wall plates) for all other storeys.
4. See design example on p. 39 for use of these tables.
5. Designer is responsible for verifying that the cumulative tension demand forces do not exceed the factored tensile resistance shown. See Step 2 in design example on p. 40.
6. System capacity assumes top plate termination. See p. 34 for details. For bridge block termination, reduce top storey capacity according to cripple wall studs load table on p. 35.

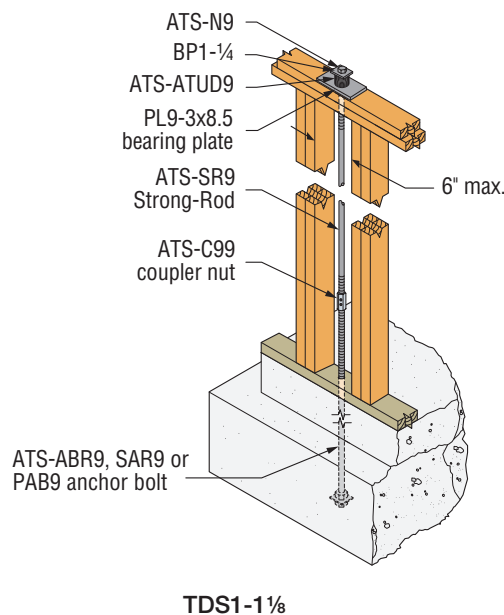
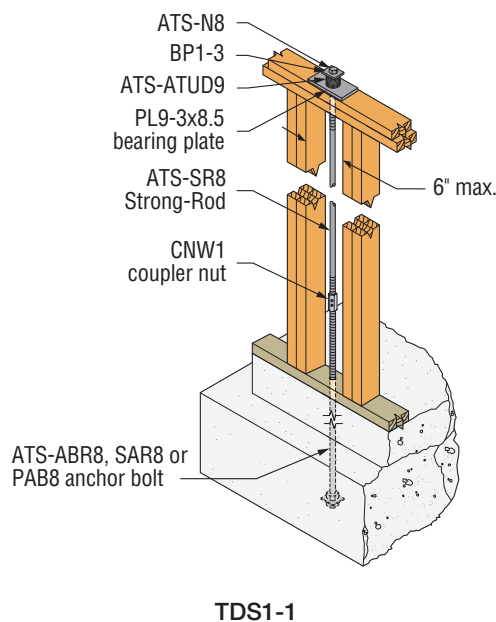

Anchorage-to-concrete and foundation design by Designer. For bridge block termination, reduce top-storey capacity as per p. 35.

Strong-Rod™ ATS Pre-Engineered Runs

Two-Storey Systems

	ATS System		TDS2-5%		TDS2-3%		TDS2-7%	
	Plates/Studs		D.Fir-L	S-P-F	D.Fir-L	S-P-F	D.Fir-L	S-P-F
2nd Floor	Factored Tensile Resistance, T_r	lb.	8780	8780	9530	9530	9530	9530
		kN	39.11	39.11	42.45	42.45	42.45	42.45
	8' Posts	2x4 framing	(1) 2x4 each side	(2) 2x4 each side	(2) 2x4 each side	(2) 2x4 each side	(2) 2x4 each side	(2) 2x4 each side
		2x6 framing	(1) 2x6 each side	(1) 2x6 each side	(1) 2x6 each side	(1) 2x6 each side	(1) 2x6 each side	(1) 2x6 each side
Incremental Bearing Resistance	lb.	8780	8780	12980	12980	17095	12940	
	kN	39.11	39.11	57.82	57.82	76.15	57.64	
1st Floor	Factored Tensile Resistance, T_r	lb.	8780	8780	12980	12980	17955	17955
		kN	39.11	39.11	57.82	57.82	79.98	79.98
	8' Posts	2x4 framing	(1) 2x4 each side	(2) 2x4 each side	(2) 2x4 each side	(2) 2x4 each side	(2) 2x4 each side	(3) 2x4 each side
		2x6 framing	(1) 2x6 each side	(1) 2x6 each side	(1) 2x6 each side	(1) 2x6 each side	(1) 2x6 each side	(2) 2x6 each side

1. Unless specifically requested, anchor bolts are not included in the system runs.
2. Post design is based on the tension capacity of the system. The Designer is responsible for verifying that the wood posts are capable of resisting all required load combinations.
3. Total vertical displacement of each storey, or between restraints, meets the 0.300" (7.6 mm) for regular-strength Strong-Rod runs. High-strength Strong-Rod runs exceed the total vertical displacement limit of 0.300" (7.6 mm) for each storey. The total vertical displacement limit may be exceeded if it can be demonstrated that the shearwall drift limit and deformation compatibility are met when accounting for all sources of vertical displacements. Total vertical

- displacement of the individual pre-engineered runs assumes 6' rod length at the top storey and 8' rod length plus 14" floor depth (including wall plates) for all other storeys.
4. See design example on p. 39 for use of these tables.
5. Designer is responsible for verifying that the cumulative tension demand forces do not exceed the factored tensile resistance shown. See Step 2 in design example on p. 40.
6. System capacity assumes top plate termination. See p. 34 for details. For bridge block termination, reduce top storey capacity according to cripple wall studs load table on p. 35.

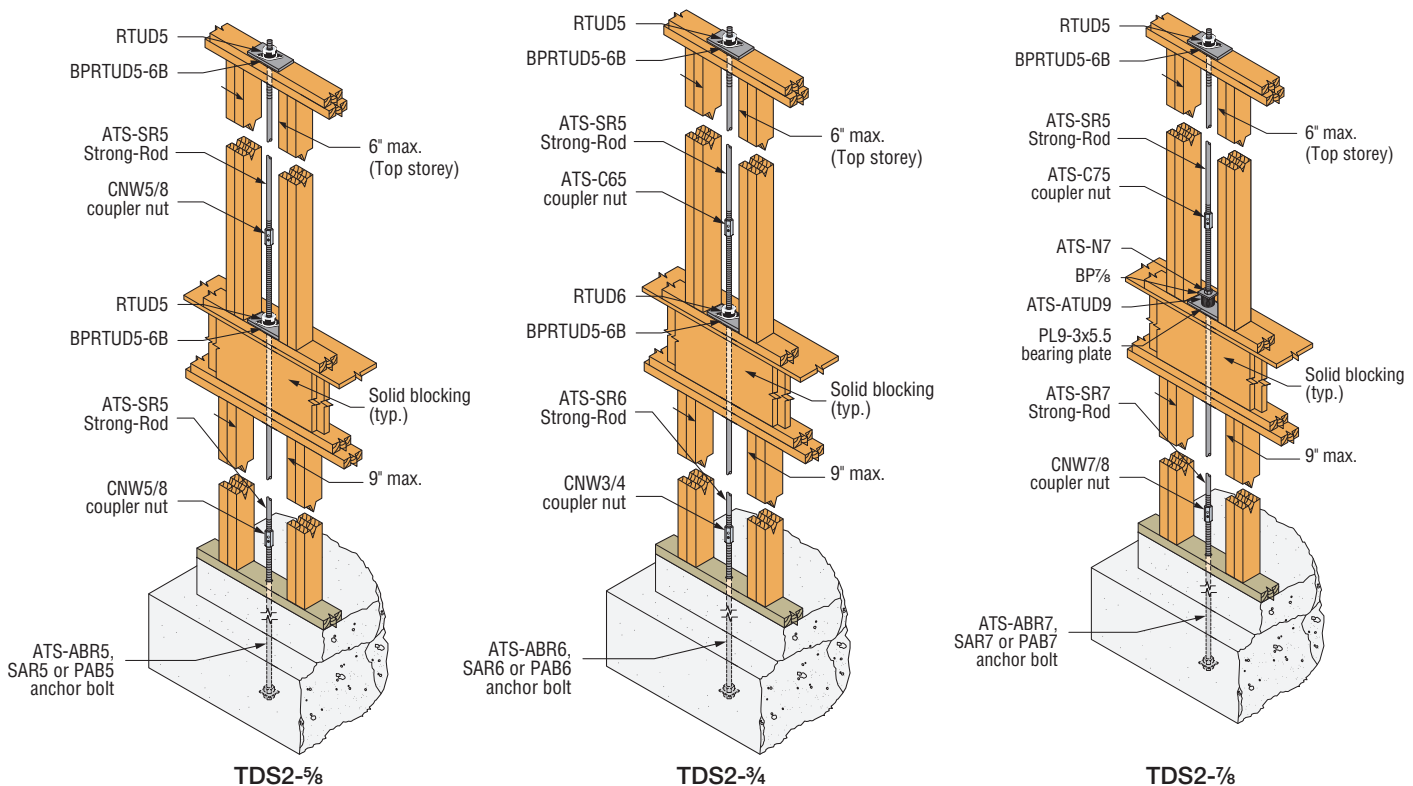

Anchorage-to-concrete and foundation design by Designer. For bridge block termination, reduce top-storey capacity as per p. 35.

Strong-Rod™ ATS Pre-Engineered Runs

Two-Storey Systems (cont.)

ATS System		TDS2-1		TDS2-1½		TDS2-¾H		
2nd Floor	Plates/Studs	D.Fir-L	S-P-F	D.Fir-L	S-P-F	D.Fir-L	S-P-F	
	Factored Tensile Resistance, T_r	lb.	14055	13705	18670	18670	18670	18670
kN		62.61	61.05	83.16	83.16	83.16	83.16	
8' Posts	2x4 framing	(2) 2x4 each side	(2) 2x4 each side	(2) 2x4 each side	(3) 2x4 each side	(2) 2x4 each side	(2) 2x4 each side	
	2x6 framing	(1) 2x6 each side	(1) 2x6 each side	(1) 2x6 each side	(1) 2x6 each side	(1) 2x6 each side	(1) 2x6 each side	
Incremental Bearing Resistance	lb.	17095	12940	17095	12940	17095	12940	
	kN	76.15	57.64	76.15	57.64	76.15	57.64	
1st Floor	Factored Tensile Resistance, T_r	lb.	23550	23550	29650	29650	35765	31610
		kN	104.90	104.90	132.07	132.07	159.31	140.80
	8' Posts	2x4 framing	(3) 2x4 each side	(3) 2x4 each side	(4) 2x4 each side	(4) 2x4 each side	(4) 2x4 each side	(4) 2x4 each side
		2x6 framing	(2) 2x6 each side	(2) 2x6 each side	(2) 2x6 each side	(3) 2x6 each side	(2) 2x6 each side	(2) 2x6 each side

1. Unless specifically requested, anchor bolts are not included in the system runs.
2. Post design is based on the tension capacity of the system. The Designer is responsible for verifying that the wood posts are capable of resisting all required load combinations.
3. Total vertical displacement of each storey, or between restraints, meets the 0.300" (7.6 mm) for regular-strength Strong-Rod runs. High-strength Strong-Rod runs exceed the total vertical displacement limit of 0.300" (7.6 mm) for each storey. The total vertical displacement limit may be exceeded if it can be demonstrated that the shearwall drift limit and deformation compatibility are met when accounting for all sources of vertical displacements. Total vertical

- displacement of the individual pre-engineered runs assumes 6' rod length at the top storey and 8' rod length plus 14" floor depth (including wall plates) for all other storeys.
4. See design example on p. 39 for use of these tables.
5. Designer is responsible for verifying that the cumulative tension demand forces do not exceed the factored tensile resistance shown. See Step 2 in design example on p. 40.
6. System capacity assumes top plate termination. See p. 34 for details. For bridge block termination, reduce top storey capacity according to cripple wall studs load table on p. 35.

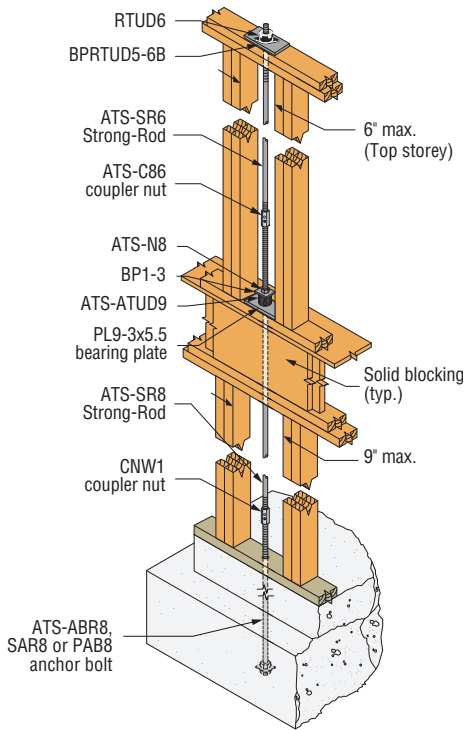

TDS2-1

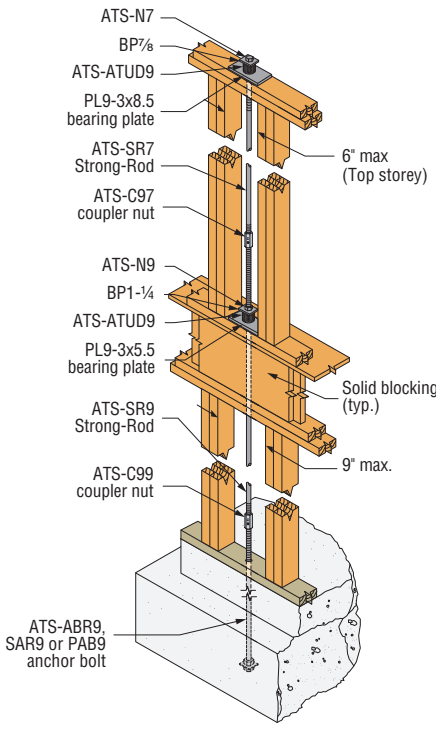

TDS2-1½

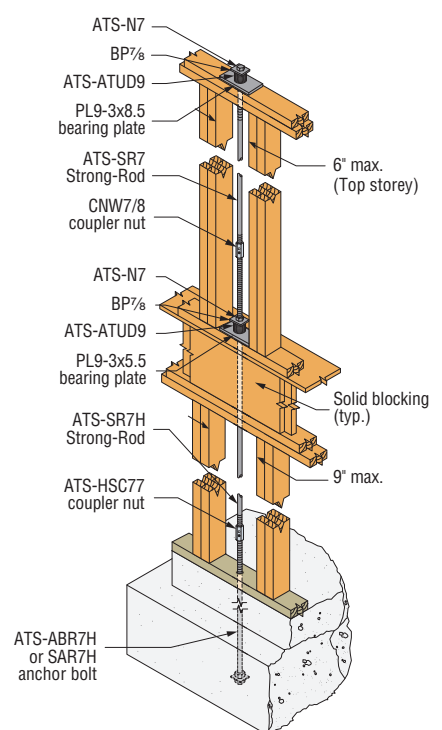

TDS2-¾H

Anchorage-to-concrete and foundation design by Designer. For bridge block termination, reduce top-storey capacity as per p. 35.

Three-Storey Systems

ATS System			TDS3-5%		TDS3-¾		TDS3-7/8	
3rd Floor	Plates/Studs		D.Fir-L	S-P-F	D.Fir-L	S-P-F	D.Fir-L	S-P-F
	Factored Tensile Resistance, T _r	lb.		8780	8780	9530	9530	9530
kN			39.11	39.11	42.45	42.45	42.45	42.45
8' Posts	2x4 framing	(1) 2x4 each side	(2) 2x4 each side	(2) 2x4 each side	(2) 2x4 each side	(2) 2x4 each side	(2) 2x4 each side	(2) 2x4 each side
	2x6 framing	(1) 2x6 each side	(1) 2x6 each side	(1) 2x6 each side	(1) 2x6 each side	(1) 2x6 each side	(1) 2x6 each side	(1) 2x6 each side
Incremental Bearing Resistance	lb.		8780	8780	12980	12980	17095	12940
	kN		39.11	39.11	57.82	57.82	76.15	57.64
2nd Floor	Factored Tensile Resistance, T _r	lb.	8780	8780	12980	12980	17955	17955
		kN	39.11	39.11	57.82	57.82	79.98	79.98
8' Posts	2x4 framing	(1) 2x4 each side	(2) 2x4 each side	(2) 2x4 each side	(2) 2x4 each side	(2) 2x4 each side	(2) 2x4 each side	(2) 2x4 each side
	2x6 framing	(1) 2x6 each side	(1) 2x6 each side	(1) 2x6 each side	(1) 2x6 each side	(1) 2x6 each side	(1) 2x6 each side	(1) 2x6 each side
Incremental Bearing Resistance	lb.		8780	8780	12980	12980	17095	12940
	kN		39.11	39.11	57.82	57.82	76.15	57.64
1st Floor	Factored Tensile Resistance, T _r	lb.	8780	8780	12980	12980	17955	17955
		kN	39.11	39.11	57.82	57.82	79.98	79.98
8' Posts	2x4 framing	(1) 2x4 each side	(2) 2x4 each side	(2) 2x4 each side	(2) 2x4 each side	(2) 2x4 each side	(2) 2x4 each side	(3) 2x4 each side
	2x6 framing	(1) 2x6 each side	(1) 2x6 each side	(1) 2x6 each side	(1) 2x6 each side	(1) 2x6 each side	(1) 2x6 each side	(2) 2x6 each side

1. Unless specifically requested, anchor bolts are not included in the system runs.
2. Post design is based on the tension capacity of the system. The Designer is responsible for verifying that the wood posts are capable of resisting all required load combinations.
3. Total vertical displacement of each storey, or between restraints, meets the 0.300" (7.6 mm) for regular-strength Strong-Rod runs. High-strength Strong-Rod runs exceed the total vertical displacement limit of 0.300" (7.6 mm) for each storey. The total vertical displacement limit may be exceeded if it can be demonstrated that the shearwall drift limit and deformation compatibility are met when accounting for all sources of vertical displacements. Total vertical

displacement of the individual pre-engineered runs assumes 6' rod length at the top storey and 8' rod length plus 14" floor depth (including wall plates) for all other storeys.

4. See design example on p. 39 for use of these tables.
5. Designer is responsible for verifying that the cumulative tension demand forces do not exceed the factored tensile resistance shown. See Step 2 in design example on p. 40.
6. System capacity assumes top plate termination. See p. 34 for details. For bridge block termination, reduce top storey capacity according to cripple wall studs load table on p. 35.

Three-Storey Systems (cont.)

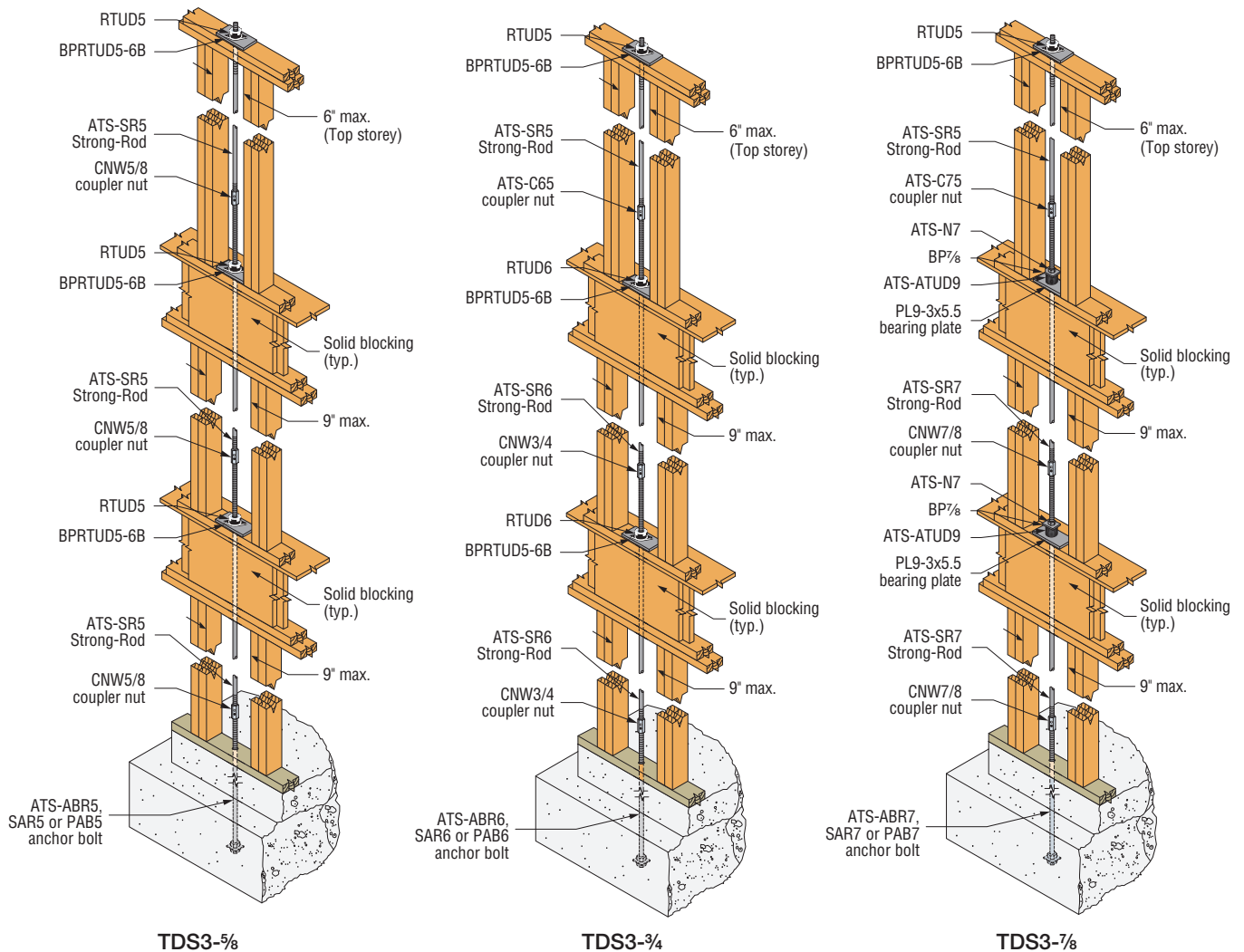

Anchorage-to-concrete and foundation design by Designer. For bridge block termination, reduce top-storey capacity as per p. 35.

Three-Storey Systems (cont.)

ATS System			TDS3-1		TDS3-1½		TDS3-¾H	
3rd Floor	Plates/Studs		D.Fir-L	S-P-F	D.Fir-L	S-P-F	D.Fir-L	S-P-F
	Factored Tensile Resistance, T _r	lb.		14055	13705	15350	12940	14055
kN			62.61	61.05	68.37	57.64	62.61	61.05
8' Posts	2x4 framing	(2) 2x4 each side	(2) 2x4 each side	(2) 2x4 each side	(2) 2x4 each side	(2) 2x4 each side	(2) 2x4 each side	(2) 2x4 each side
	2x6 framing	(1) 2x6 each side	(1) 2x6 each side	(1) 2x6 each side	(1) 2x6 each side	(1) 2x6 each side	(1) 2x6 each side	(1) 2x6 each side
Incremental Bearing Resistance	lb.		17095	12940	17095	12940	17095	12940
	kN		76.15	57.64	76.15	57.64	76.15	57.64
2nd Floor	Factored Tensile Resistance, T _r	lb.	23550	23550	29650	25880	31150	26645
		kN	104.90	104.90	132.07	115.28	138.75	118.69
	8' Posts	2x4 framing	(3) 2x4 each side	(3) 2x4 each side	(4) 2x4 each side	(4) 2x4 each side	(4) 2x4 each side	(4) 2x4 each side
		2x6 framing	(2) 2x6 each side	(2) 2x6 each side	(2) 2x6 each side	(2) 2x6 each side	(2) 2x6 each side	(3) 2x6 each side
	Incremental Bearing Resistance	lb.	17095	12940	17095	12940	18670	18670
		kN	76.15	57.64	76.15	57.64	83.16	83.16
1st Floor	Factored Tensile Resistance, T _r	lb.	23550	23550	29650	29650	37145	37145
		kN	104.90	104.90	132.07	132.07	165.46	165.46
	8' Posts	2x4 framing	(3) 2x4 each side	(3) 2x4 each side	(4) 2x4 each side	(4) 2x4 each side	(4) 2x4 each side	(5) 2x4 each side
		2x6 framing	(2) 2x6 each side	(2) 2x6 each side	(2) 2x6 each side	(3) 2x6 each side	(2) 2x6 each side	(3) 2x6 each side

1. Unless specifically requested, anchor bolts are not included in the system runs.
2. Post design is based on the tension capacity of the system. The Designer is responsible for verifying that the wood posts are capable of resisting all required load combinations.
3. Total vertical displacement of each storey, or between restraints, meets the 0.300" (7.6 mm) for regular-strength Strong-Rod runs. High-strength Strong-Rod runs exceed the total vertical displacement limit of 0.300" (7.6 mm) for each storey. The total vertical displacement limit may be exceeded if it can be demonstrated that the shearwall drift limit and deformation compatibility are met when accounting for all sources of vertical displacements. Total vertical

displacement of the individual pre-engineered runs assumes 6' rod length at the top storey and 8' rod length plus 14" floor depth (including wall plates) for all other storeys.

4. See design example on p. 39 for use of these tables.
5. Designer is responsible for verifying that the cumulative tension demand forces do not exceed the factored tensile resistance shown. See Step 2 in design example on p. 40.
6. System capacity assumes top plate termination. See p. 34 for details. For bridge block termination, reduce top storey capacity according to cripple wall studs load table on p. 35.

Strong-Rod™ ATS Pre-Engineered Runs

Three-Storey Systems (cont.)

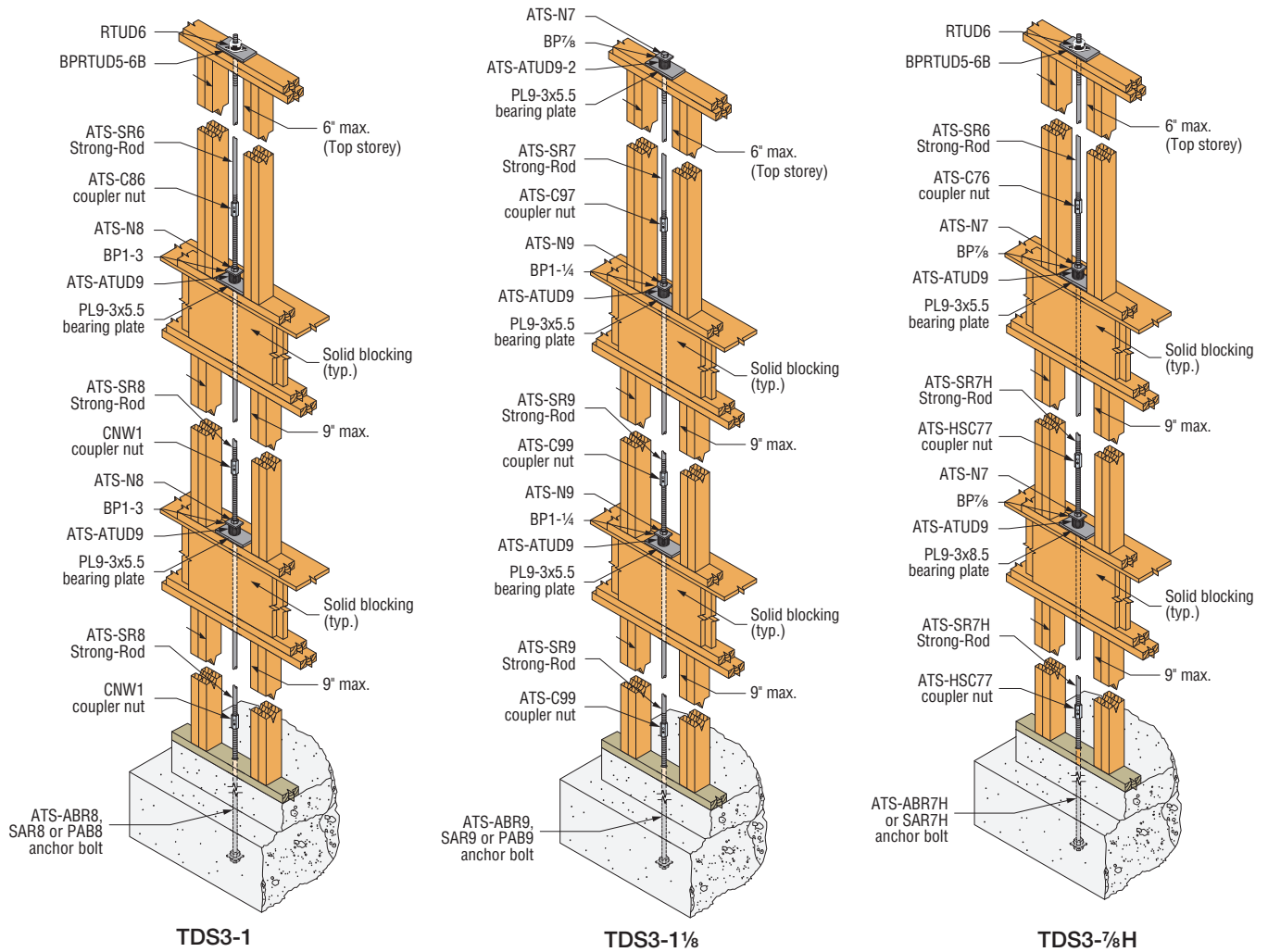

Anchorage-to-concrete and foundation design by Designer. For bridge block termination, reduce top-storey capacity as per p. 35.

Strong-Rod™ ATS Pre-Engineered Runs

Three-Storey Systems (cont.)

ATS System		TDS3-1½H		
3rd Floor	Plates/Studs	D.Fir-L	S-P-F	
	Factored Tensile Resistance, T_r	lb.	15350	15350
kN		68.37	68.37	
8' Posts	2x4 framing	(2) 2x4 each side	(2) 2x4 each side	
	2x6 framing	(1) 2x6 each side	(1) 2x6 each side	
Incremental Bearing Resistance	lb.	17095	12940	
	kN	76	58	
2nd Floor	Plates/Studs	D.Fir-L	S-P-F	
	Factored Tensile Resistance, T_r	lb.	32445	28290
kN		144.52	126.01	
8' Posts	2x4 framing	(4) 2x4 each side	(4) 2x4 each side	
	2x6 framing	(2) 2x6 each side	(4) 2x6 each side	
Incremental Bearing Resistance	lb.	18670	18670	
	kN	83	83	
1st Floor	Plates/Studs	D.Fir-L	S-P-F	
	Factored Tensile Resistance, T_r	lb.	51115	46960
kN		227.68	209.18	
8' Posts	2x4 framing	—	—	
	2x6 framing	(3) 2x6 each side	(4) 2x6 each side	

1. Unless specifically requested, anchor bolts are not included in the system runs.
2. Post design is based on the tension capacity of the system. The Designer is responsible for verifying that the wood posts are capable of resisting all required load combinations.
3. Total vertical displacement of each storey, or between restraints, meets the 0.300" (7.6 mm) for regular-strength Strong-Rod runs. High-strength Strong-Rod runs exceed the total vertical displacement limit of 0.300" (7.6 mm) for each storey. The total vertical displacement limit may be exceeded if it can be demonstrated that the shearwall drift limit and deformation compatibility are met when accounting for all sources of vertical displacements. Total vertical displacement of the individual pre-engineered runs assumes 6' rod length at the top storey and 8' rod length plus 14" floor depth (including wall plates) for all other storeys.
4. See design example on p. 39 for use of these tables.
5. Designer is responsible for verifying that the cumulative tension demand forces do not exceed the factored tensile resistance shown. See Step 2 in design example on p. 40.
6. System capacity assumes top plate termination. See p. 34 for details. For bridge block termination, reduce top storey capacity according to cripple wall studs load table on p. 35.

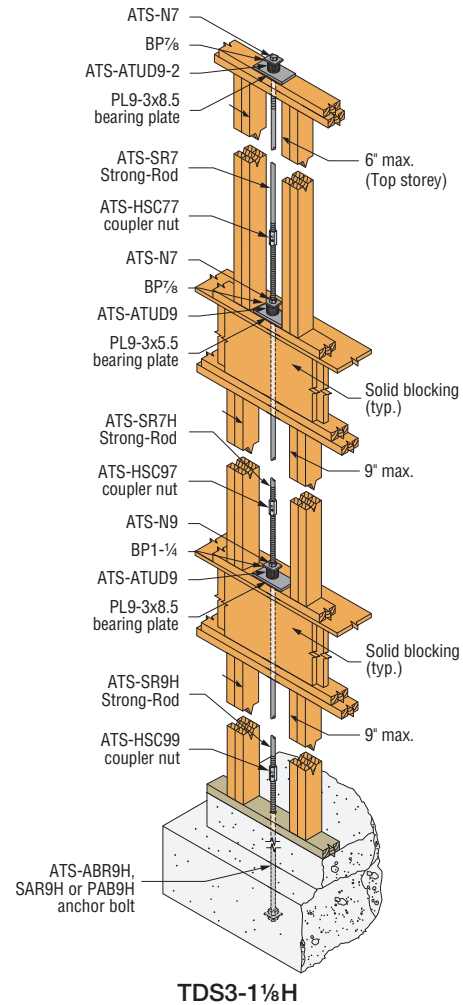

Anchorage-to-concrete and foundation design by Designer. For bridge block termination, reduce top-storey capacity as per p. 35.

Four-Storey Systems

ATS System			TDS4-5/8		TDS4-3/4		TDS4-7/8	
4th Floor	Plates/Studs		D.Fir-L	S-P-F	D.Fir-L	S-P-F	D.Fir-L	S-P-F
	Factored Tensile Resistance, T_r	lb.		8780	8780	9530	9530	9530
kN			39.11	39.11	42.45	42.45	42.45	42.45
8' Posts	2x4 framing		(1) 2x4 each side	(2) 2x4 each side	(2) 2x4 each side	(2) 2x4 each side	(2) 2x4 each side	(2) 2x4 each side
	2x6 framing		(1) 2x6 each side	(1) 2x6 each side	(1) 2x6 each side	(1) 2x6 each side	(1) 2x6 each side	(1) 2x6 each side
Incremental Bearing Resistance	lb.		8780	8780	9530	9530	9530	9530
	kN		39.11	39.11	42.45	42.45	42.45	42.45
3rd Floor	Factored Tensile Resistance, T_r	lb.	8780	8780	9530	9530	9530	9530
		kN	39.11	39.11	42.45	42.45	42.45	42.45
	8' Posts	2x4 framing	(1) 2x4 each side	(2) 2x4 each side	(2) 2x4 each side	(2) 2x4 each side	(2) 2x4 each side	(2) 2x4 each side
		2x6 framing	(1) 2x6 each side	(1) 2x6 each side	(1) 2x6 each side	(1) 2x6 each side	(1) 2x6 each side	(1) 2x6 each side
	Incremental Bearing Resistance	lb.	8780	8780	12980	12980	17095	12940
kN		39.11	39.11	57.82	57.82	76.15	57.64	
2nd Floor	Factored Tensile Resistance, T_r	lb.	8780	8780	12980	12980	17955	17955
		kN	39.11	39.11	57.82	57.82	79.98	79.98
	8' Posts	2x4 framing	(1) 2x4 each side	(2) 2x4 each side	(2) 2x4 each side	(2) 2x4 each side	(2) 2x4 each side	(3) 2x4 each side
		2x6 framing	(1) 2x6 each side	(1) 2x6 each side	(1) 2x6 each side	(1) 2x6 each side	(1) 2x6 each side	(2) 2x6 each side
	Incremental Bearing Resistance	lb.	8780	8780	12980	12980	17095	12940
kN		39.11	39.11	57.82	57.82	76.15	57.64	
1st Floor	Factored Tensile Resistance, T_r	lb.	8780	8780	12980	12980	17955	17955
		kN	39.11	39.11	57.82	57.82	79.98	79.98
	8' Posts	2x4 framing	(1) 2x4 each side	(2) 2x4 each side	(2) 2x4 each side	(2) 2x4 each side	(2) 2x4 each side	(3) 2x4 each side
		2x6 framing	(1) 2x6 each side	(1) 2x6 each side	(1) 2x6 each side	(1) 2x6 each side	(1) 2x6 each side	(2) 2x6 each side

1. Unless specifically requested, anchor bolts are not included in the system runs.
2. Post design is based on the tension capacity of the system. The Designer is responsible for verifying that the wood posts are capable of resisting all required load combinations.
3. Total vertical displacement of each storey, or between restraints, meets the 0.300" (7.6 mm) for regular-strength Strong-Rod runs. High-strength Strong-Rod runs exceed the total vertical displacement limit of 0.300" (7.6 mm) for each storey. The total vertical displacement limit may be exceeded if it can be demonstrated that the shearwall drift limit and deformation compatibility are met when accounting for all sources of vertical displacements. Total vertical

- displacement of the individual pre-engineered runs assumes 6' rod length at the top storey and 8' rod length plus 14" floor depth (including wall plates) for all other storeys.
4. See design example on p. 39 for use of these tables.
 5. Designer is responsible for verifying that the cumulative tension demand forces do not exceed the factored tensile resistance shown. See Step 2 in design example on p. 40.
 6. System capacity assumes top plate termination. See p. 34 for details. For bridge block termination, reduce top storey capacity according to cripple wall studs load table on p. 35.

Strong-Rod™ ATS Pre-Engineered Runs

Four-Storey Systems (cont.)

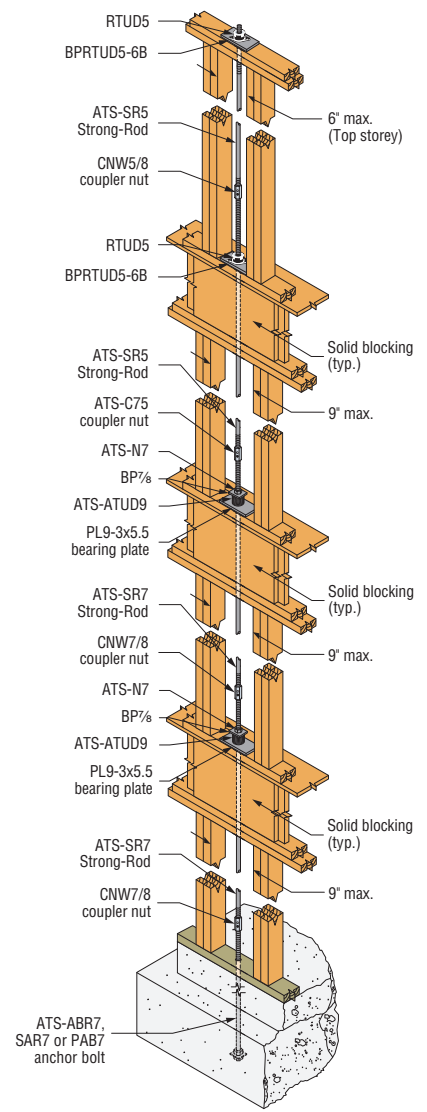
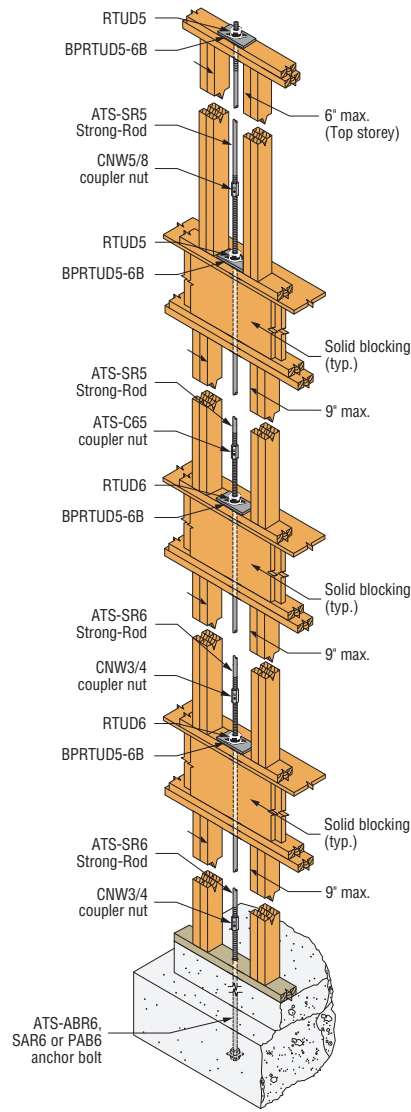
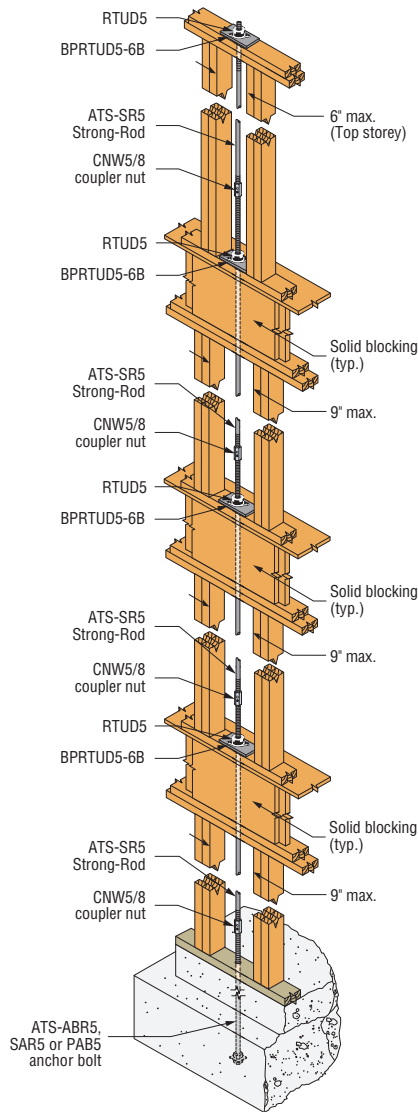

Anchorage-to-concrete and foundation design by Designer. For bridge block termination, reduce top-storey capacity as per p. 35.

Four-Storey Systems (cont.)

ATS System		TDS4-1		TDS4-1½		TDS4-7/8H		
Plates/Studs		D.Fir-L	S-P-F	D.Fir-L	S-P-F	D.Fir-L	S-P-F	
4th Floor	Factored Tensile Resistance, T _r	lb.	14055	13705	14055	13705	14055	13705
		kN	62.61	61.05	62.61	61.05	62.61	61.05
	8' Posts	2x4 framing	(2) 2x4 each side	(2) 2x4 each side	(2) 2x4 each side	(2) 2x4 each side	(2) 2x4 each side	(2) 2x4 each side
		2x6 framing	(1) 2x6 each side	(1) 2x6 each side	(1) 2x6 each side	(1) 2x6 each side	(1) 2x6 each side	(1) 2x6 each side
	Incremental Bearing Resistance	lb.	15350	12940	15350	12940	15350	12940
		kN	68.37	57.64	68.37	57.64	68.37	57.64
3rd Floor	Factored Tensile Resistance, T _r	lb.	19260	19260	19260	19260	19260	19260
		kN	85.79	85.79	85.79	85.79	85.79	85.79
	8' Posts	2x4 framing	(2) 2x4 each side	(2) 2x4 each side	(3) 2x4 each side	(3) 2x4 each side	(3) 2x4 each side	(3) 2x4 each side
		2x6 framing	(1) 2x6 each side	(1) 2x6 each side	(1) 2x6 each side	(2) 2x6 each side	(1) 2x6 each side	(2) 2x6 each side
	Incremental Bearing Resistance	lb.	17095	12940	17095	12940	18670	18670
		kN	76.15	57.64	76.15	57.64	83.16	83.16
2nd Floor	Factored Tensile Resistance, T _r	lb.	23550	23550	29650	29650	37145	37145
		kN	104.90	104.90	132.07	132.07	165.46	165.46
	8' Posts	2x4 framing	(3) 2x4 each side	(3) 2x4 each side	(4) 2x4 each side	(4) 2x4 each side	(4) 2x4 each side	(4) 2x4 each side
		2x6 framing	(2) 2x6 each side	(2) 2x6 each side	(2) 2x6 each side	(3) 2x6 each side	(2) 2x6 each side	(3) 2x6 each side
	Incremental Bearing Resistance	lb.	17095	12940	17095	12940	18670	18670
		kN	76.15	57.64	76.15	57.64	83.16	83.16
1st Floor	Factored Tensile Resistance, T _r	lb.	23550	23550	29650	29650	37145	37145
		kN	104.90	104.90	132.07	132.07	165.46	165.46
	8' Posts	2x4 framing	(3) 2x4 each side	(3) 2x4 each side	(4) 2x4 each side	(4) 2x4 each side	(4) 2x4 each side	(5) 2x4 each side
		2x6 framing	(2) 2x6 each side	(2) 2x6 each side	(2) 2x6 each side	(3) 2x6 each side	(2) 2x6 each side	(3) 2x6 each side

1. Unless specifically requested, anchor bolts are not included in the system runs.
2. Post design is based on the tension capacity of the system. The Designer is responsible for verifying that the wood posts are capable of resisting all required load combinations.
3. Total vertical displacement of each storey, or between restraints, meets the 0.300" (7.6 mm) for regular-strength Strong-Rod runs. High-strength Strong-Rod runs exceed the total vertical displacement limit of 0.300" (7.6 mm) for each storey. The total vertical displacement limit may be exceeded if it can be demonstrated that the shearwall drift limit and deformation compatibility are met when accounting for all sources of vertical displacements. Total vertical

- displacement of the individual pre-engineered runs assumes 6' rod length at the top storey and 8' rod length plus 14" floor depth (including wall plates) for all other storeys.
4. See design example on p. 39 for use of these tables.
5. Designer is responsible for verifying that the cumulative tension demand forces do not exceed the factored tensile resistance shown. See Step 2 in design example on p. 40.
6. System capacity assumes top plate termination. See p. 34 for details. For bridge block termination, reduce top storey capacity according to cripple wall studs load table on p. 35.

Strong-Rod™ ATS Pre-Engineered Runs

Four-Storey Systems (cont.)

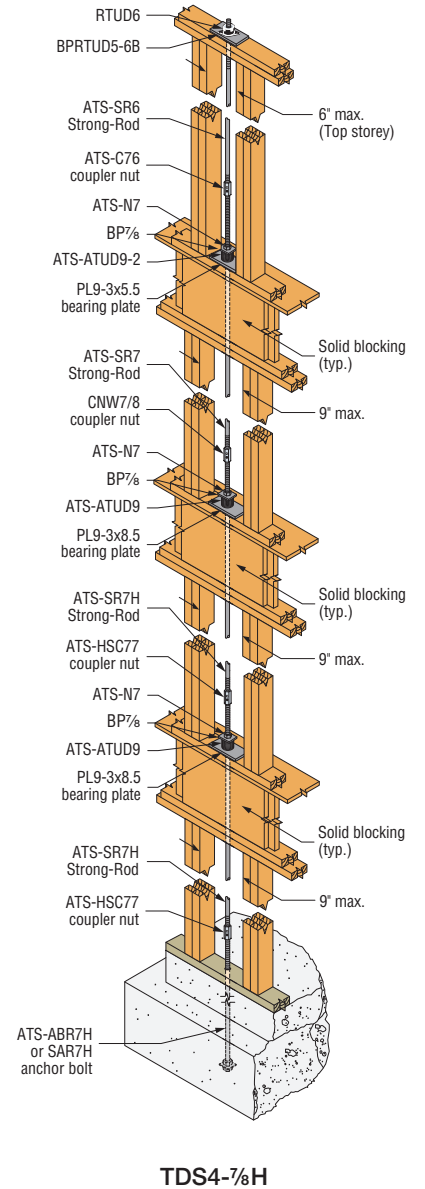
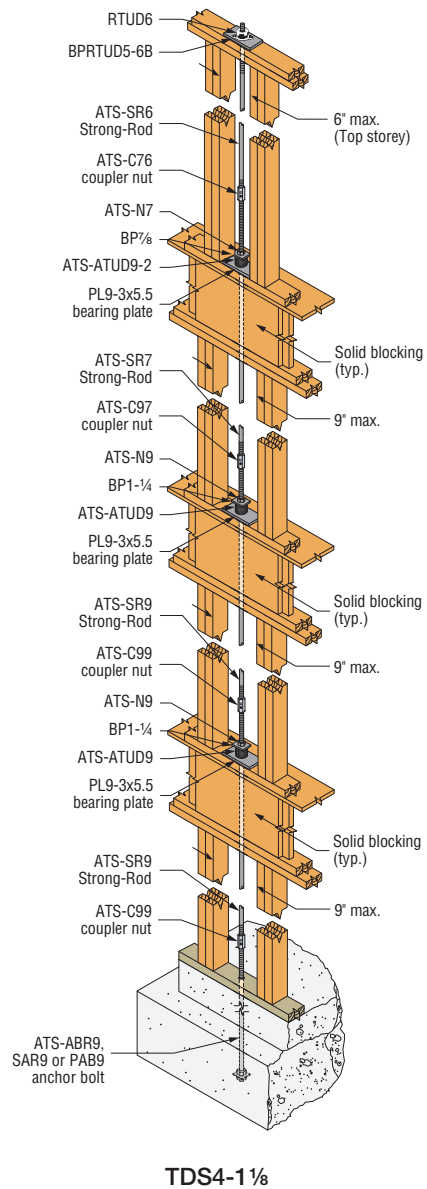
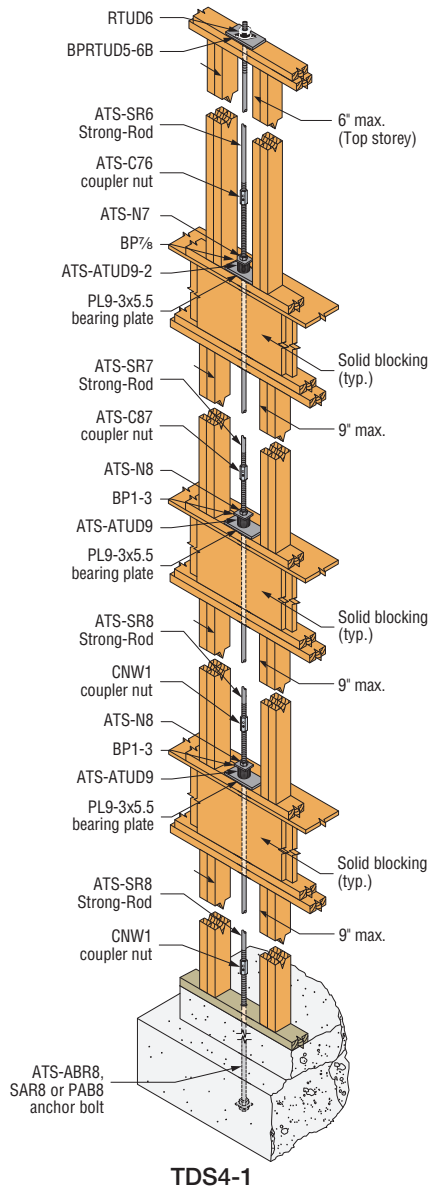

Anchorage-to-concrete and foundation design by Designer. For bridge block termination, reduce top-storey capacity as per p. 35.

Strong-Rod™ ATS Pre-Engineered Runs

Four-Storey Systems (cont.)

ATS System		TDS4-1 1/8H		
4th Floor	Plates/Studs		D.Fir-L	S-P-F
	Factored Tensile Resistance, T_r	lb.		15350
kN				68.37
	8' Posts	2x4 framing	(3) 2x4 each side	(3) 2x4 each side
2x6 framing		(1) 2x6 each side	(2) 2x6 each side	
Incremental Bearing Resistance	lb.		15350	12940
	kN		68.37	57.64
3rd Floor	Factored Tensile Resistance, T_r	lb.	30700	28290
		kN	136.75	126.01
8' Posts	2x4 framing	(4) 2x4 each side	(4) 2x4 each side	
	2x6 framing	(2) 2x6 each side	(3) 2x6 each side	
Incremental Bearing Resistance	lb.		18670	18670
	kN		83.16	83.16
2nd Floor	Factored Tensile Resistance, T_r	lb.	41205	41205
		kN	183.54	183.54
8' Posts	2x4 framing	(5) 2x4 each side	(5) 2x4 each side	
	2x6 framing	(3) 2x6 each side	(4) 2x6 each side	
Incremental Bearing Resistance	lb.		18670	18670
	kN		83.16	83.16
1st Floor	Factored Tensile Resistance, T_r	lb.	63900	63900
		kN	284.63	284.63
8' Posts	2x4 framing	—	—	
	2x6 framing	(4) 2x6 each side	(5) 2x6 each side	

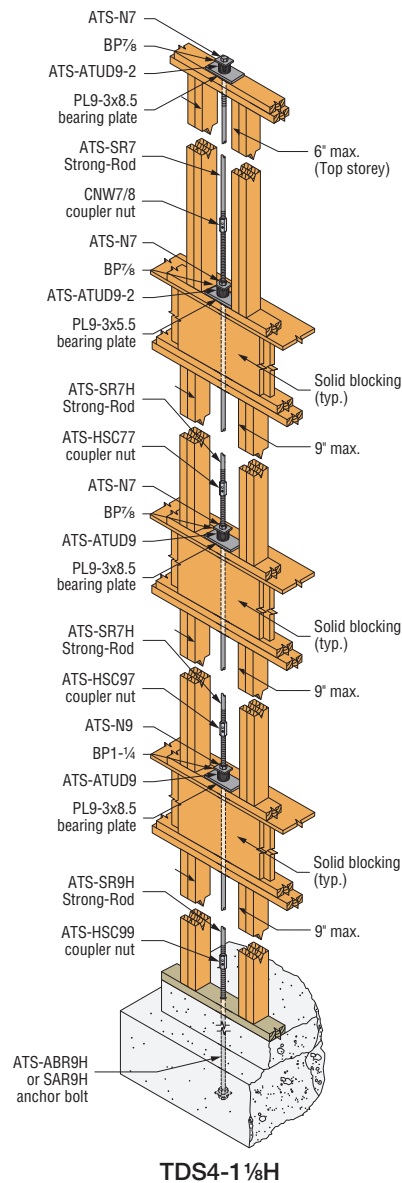

1. Unless specifically requested, anchor bolts are not included in the system runs.
2. Post design is based on the tension capacity of the system. The Designer is responsible for verifying that the wood posts are capable of resisting all required load combinations.
3. Total vertical displacement of each storey, or between restraints, meets the 0.300" (7.6 mm) for regular-strength Strong-Rod runs. High-strength Strong-Rod runs exceed the total vertical displacement limit of 0.300" (7.6 mm) for each storey. The total vertical displacement limit may be exceeded if it can be demonstrated that the shearwall drift limit and deformation compatibility are met when accounting for all sources of vertical displacements. Total vertical displacement of the individual pre-engineered runs assumes 6' rod length at the top storey and 8' rod length plus 14" floor depth (including wall plates) for all other storeys.
4. See design example on p. 39 for use of these tables.
5. Designer is responsible for verifying that the cumulative tension demand forces do not exceed the factored tensile resistance shown. See Step 2 in design example on p. 40.
6. System capacity assumes top plate termination. See p. 34 for details. For bridge block termination, reduce top storey capacity according to cripple wall studs load table on p. 35.

Anchorage-to-concrete and foundation design by Designer. For bridge block termination, reduce top-storey capacity as per p. 35.

Strong-Rod™ ATS Pre-Engineered Runs

Five-Storey Systems

ATS System		TDS5-3/4		TDS5-7/8		TDS5-1		
5th Floor	Plates/Studs	D.Fir-L	S-P-F	D.Fir-L	S-P-F	D.Fir-L	S-P-F	
	Factored Tensile Resistance, Tr	lb.	9530	9530	9530	9530	14055	13705
kN		42.45	42.45	42.45	42.45	62.61	61.05	
8' Posts	2x4 framing	(2) 2x4 each side	(2) 2x4 each side	(2) 2x4 each side	(2) 2x4 each side	(2) 2x4 each side	(2) 2x4 each side	
	2x6 framing	(1) 2x6 each side	(1) 2x6 each side	(1) 2x6 each side	(1) 2x6 each side	(1) 2x6 each side	(1) 2x6 each side	
	2x8 framing	(1) 2x8 each side	(1) 2x8 each side	(1) 2x8 each side	(1) 2x8 each side	(1) 2x8 each side	(1) 2x8 each side	
Incremental Bearing Resistance	lb.	12980	12980	14055	13705	15350	12940	
	kN	57.82	57.82	62.61	61.05	68.37	57.64	
4th Floor	Factored Tensile Resistance, Tr	lb.	12980	12980	14055	14055	19260	19260
		kN	57.82	57.82	62.61	62.61	85.79	85.79
8' Posts	2x4 framing	(2) 2x4 each side	(2) 2x4 each side	(2) 2x4 each side	(2) 2x4 each side	(3) 2x4 each side	(3) 2x4 each side	
	2x6 framing	(1) 2x6 each side	(1) 2x6 each side	(1) 2x6 each side	(1) 2x6 each side	(1) 2x6 each side	(2) 2x6 each side	
	2x8 framing	(1) 2x8 each side	(1) 2x8 each side	(1) 2x8 each side	(1) 2x8 each side	(1) 2x8 each side	(1) 2x8 each side	
Incremental Bearing Resistance	lb.	12980	12980	14055	13705	15350	12940	
	kN	57.82	57.82	62.61	61.05	68.37	57.64	
3rd Floor	Factored Tensile Resistance, Tr	lb.	12980	12980	14055	14055	19260	19260
		kN	58	58	63	63	86	86
8' Posts	2x4 framing	(2) 2x4 each side	(2) 2x4 each side	(2) 2x4 each side	(2) 2x4 each side	(3) 2x4 each side	(3) 2x4 each side	
	2x6 framing	(1) 2x6 each side	(1) 2x6 each side	(1) 2x6 each side	(1) 2x6 each side	(1) 2x6 each side	(2) 2x6 each side	
	2x8 framing	(1) 2x8 each side	(1) 2x8 each side	(1) 2x8 each side	(1) 2x8 each side	(1) 2x8 each side	(1) 2x8 each side	
Incremental Bearing Resistance	lb.	12980	12980	17095	12940	17095	12940	
	kN	57.82	57.82	76.15	57.64	76.15	57.64	
2nd Floor	Factored Tensile Resistance, Tr	lb.	12980	12980	17955	17955	23550	23550
		kN	57.82	57.82	79.98	79.98	104.90	104.90
8' Posts	2x4 framing	(2) 2x4 each side	(2) 2x4 each side	(2) 2x4 each side	(3) 2x4 each side	(3) 2x4 each side	(3) 2x4 each side	
	2x6 framing	(1) 2x6 each side	(1) 2x6 each side	(1) 2x6 each side	(2) 2x6 each side	(2) 2x6 each side	(2) 2x6 each side	
	2x8 framing	(1) 2x8 each side	(1) 2x8 each side	(1) 2x8 each side	(1) 2x8 each side	(1) 2x8 each side	(2) 2x8 each side	
Incremental Bearing Resistance	lb.	12980	12980	17095	12940	17095	12940	
	kN	57.82	57.82	76.15	57.64	76.15	57.64	
1st Floor	Factored Tensile Resistance, Tr	lb.	12980	12980	17955	17955	23550	23550
		kN	57.82	57.82	79.98	79.98	104.90	104.90
8' Posts	2x4 framing	(2) 2x4 each side	(2) 2x4 each side	(2) 2x4 each side	(3) 2x4 each side	(3) 2x4 each side	(3) 2x4 each side	
	2x6 framing	(1) 2x6 each side	(1) 2x6 each side	(1) 2x6 each side	(2) 2x6 each side	(2) 2x6 each side	(2) 2x6 each side	
	2x8 framing	(1) 2x8 each side	(1) 2x8 each side	(1) 2x8 each side	(1) 2x8 each side	(1) 2x8 each side	(2) 2x8 each side	

1. Unless specifically requested, anchor bolts are not included in the system runs.
2. Post design is based on the tension capacity of the system. The Designer is responsible for verifying that the wood posts are capable of resisting all required load combinations.
3. Total vertical displacement of each storey, or between restraints, meets the 0.300" (7.6 mm) for regular-strength Strong-Rod runs. High-strength Strong-Rod runs exceed the total vertical displacement limit of 0.300" (7.6 mm) for each storey. The total vertical displacement limit may be exceeded if it can be demonstrated that the shearwall drift limit and deformation compatibility are met when accounting for all sources of vertical displacements. Total vertical displacement of the individual pre-engineered runs assumes 6' rod length at

the top storey and 8' rod length plus 14" floor depth (including wall plates) for all other storeys.

4. See design example on p. 39 for use of these tables.
5. Designer is responsible for verifying that the cumulative tension demand forces do not exceed the factored tensile resistance shown. See Step 2 in design example on p. 40.
6. System capacity assumes top plate termination. See p. 34 for details. For bridge block termination, reduce top storey capacity according to cripple wall studs load table on p. 35.
7. 5-storey and 6-storey runs apply only to jurisdictions with Building Code provision for Mid-Rise Wood Frame Construction.

Five-Storey Systems (cont.)

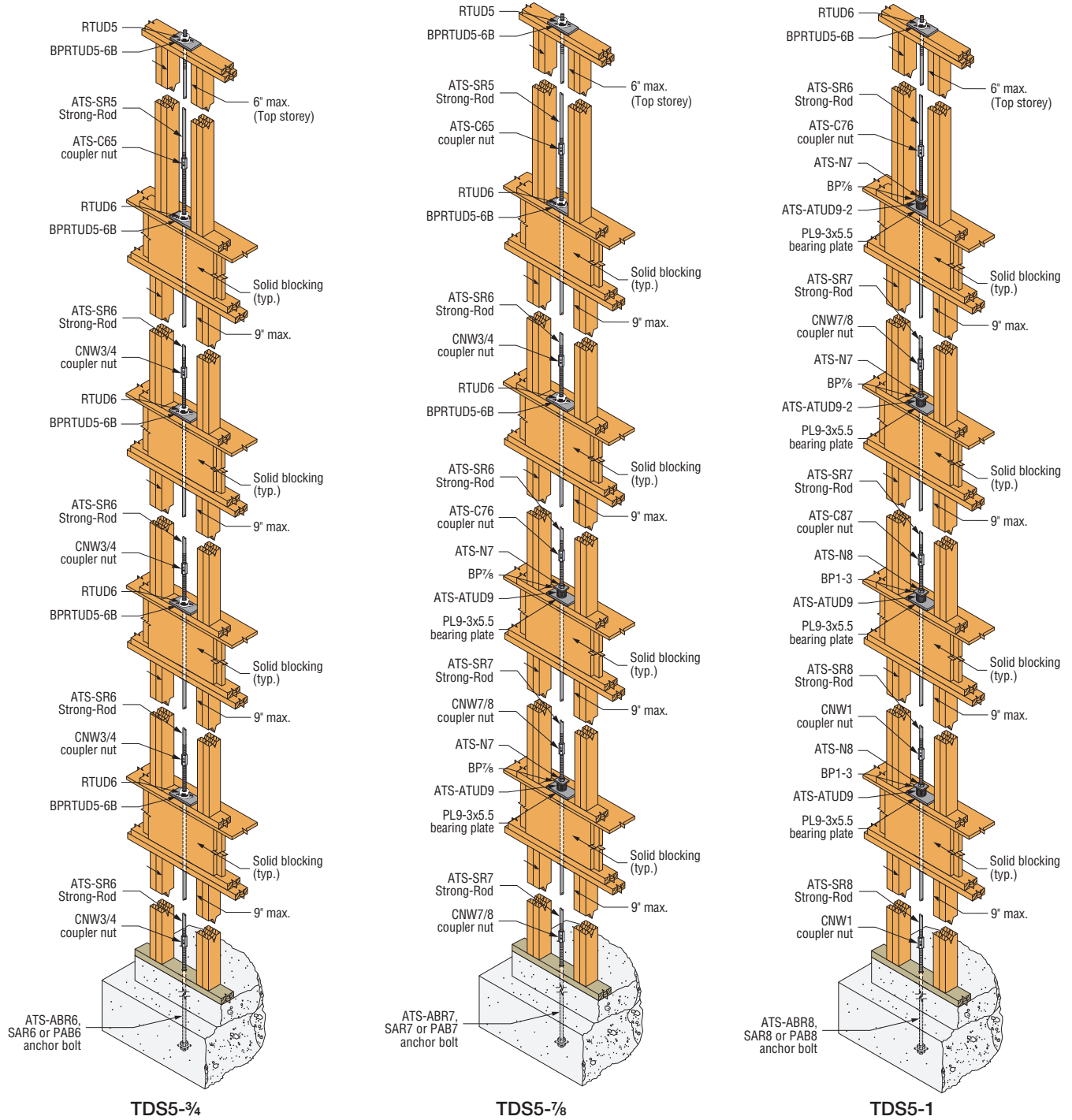

Anchorage-to-concrete and foundation design by Designer. For bridge block termination, reduce top-storey capacity as per p. 35.

Five-Storey Systems (cont.)

ATS		TDS5-1½		TDS5-1¼		TDS5-1¾		
Plates/Studs		D.Fir-L	S-P-F	D.Fir-L	S-P-F	D.Fir-L	S-P-F	
5th Floor	Factored Tensile Resistance, T_r	lb.	14195	12940	14195	12940	14195	12940
		kN	63.23	57.64	63.23	57.64	63.23	57.64
	8' Posts	2x4 framing	(2) 2x4 each side	(2) 2x4 each side	(2) 2x4 each side	(2) 2x4 each side	(2) 2x4 each side	(2) 2x4 each side
		2x6 framing	(1) 2x6 each side	(1) 2x6 each side	(1) 2x6 each side	(1) 2x6 each side	(1) 2x6 each side	(1) 2x6 each side
		2x8 framing	(1) 2x8 each side	(1) 2x8 each side	(1) 2x8 each side	(1) 2x8 each side	(1) 2x8 each side	(1) 2x8 each side
	Incremental Bearing Resistance	lb.	15350	12940	15350	12940	23890	18080
kN		68.37	57.64	68.37	57.64	106.41	80.53	
4th Floor	Factored Tensile Resistance, T_r	lb.	25170	25170	29545	25880	38085	31020
		kN	112.12	112.12	131.60	115.28	169.64	138.17
	8' Posts	2x4 framing	(3) 2x4 each side	(3) 2x4 each side	(4) 2x4 each side	(3) 2x4 each side	(5) 2x4 each side	(4) 2x4 each side
		2x6 framing	(2) 2x6 each side	(2) 2x6 each side	(2) 2x6 each side	(2) 2x6 each side	(2) 2x6 each side	(3) 2x6 each side
		2x8 framing	(1) 2x8 each side	(2) 2x8 each side	(1) 2x8 each side	(2) 2x8 each side	(2) 2x8 each side	(2) 2x8 each side
	Incremental Bearing Resistance	lb.	15350	12940	15350	12940	23890	18080
kN		68.37	57.64	68.37	57.64	106.41	80.53	
3rd Floor	Factored Tensile Resistance, T_r	lb.	25170	25170	31870	31870	40195	40195
		kN	112.12	112.12	141.96	141.96	179.04	179.04
	8' Posts	2x4 framing	(3) 2x4 each side	(3) 2x4 each side	(4) 2x4 each side	(4) 2x4 each side	(5) 2x4 each side	(5) 2x4 each side
		2x6 framing	(2) 2x6 each side	(2) 2x6 each side	(2) 2x6 each side	(3) 2x6 each side	(3) 2x6 each side	(3) 2x6 each side
		2x8 framing	(1) 2x8 each side	(2) 2x8 each side	(1) 2x8 each side	(2) 2x8 each side	(2) 2x8 each side	(2) 2x8 each side
	Incremental Bearing Resistance	lb.	17095	12940	23890	18080	23890	18080
kN		76.15	57.64	106.41	80.53	106.41	80.53	
2nd Floor	Factored Tensile Resistance, T_r	lb.	29650	29650	37655	37655	45080	45080
		kN	132.07	132.07	167.73	167.73	200.80	200.80
	8' Posts	2x4 framing	(4) 2x4 each side	(4) 2x4 each side	(4) 2x4 each side	(5) 2x4 each side	(5) 2x4 each side	—
		2x6 framing	(2) 2x6 each side	(3) 2x6 each side	(2) 2x6 each side	(3) 2x6 each side	(3) 2x6 each side	(4) 2x6 each side
		2x8 framing	(1) 2x8 each side	(2) 2x8 each side	(1) 2x8 each side	(2) 2x8 each side	(2) 2x8 each side	(3) 2x8 each side
	Incremental Bearing Resistance	lb.	17095	12940	23890	18080	23890	18080
kN		76.15	57.64	106.41	80.53	106.41	80.53	
1st Floor	Factored Tensile Resistance, T_r	lb.	29650	29650	37655	37655	45080	45080
		kN	132.07	132.07	167.73	167.73	200.80	200.80
	8' Posts	2x4 framing	(4) 2x4 each side	(4) 2x4 each side	(4) 2x4 each side	(5) 2x4 each side	(5) 2x4 each side	—
		2x6 framing	(2) 2x6 each side	(3) 2x6 each side	(2) 2x6 each side	(3) 2x6 each side	(3) 2x6 each side	(4) 2x6 each side
		2x8 framing	(1) 2x8 each side	(2) 2x8 each side	(1) 2x8 each side	(2) 2x8 each side	(2) 2x8 each side	(3) 2x8 each side

1. Unless specifically requested, anchor bolts are not included in the system runs.
2. Post design is based on the tension capacity of the system. The Designer is responsible for verifying that the wood posts are capable of resisting all required load combinations.
3. Total vertical displacement of each storey, or between restraints, meets the 0.300" (7.6 mm) for regular-strength Strong-Rod runs. High-strength Strong-Rod runs exceed the total vertical displacement limit of 0.300" (7.6 mm) for each storey. The total vertical displacement limit may be exceeded if it can be demonstrated that the shearwall drift limit and deformation compatibility are met when accounting for all sources of vertical displacements. Total vertical displacement of the individual pre-engineered runs assumes 6' rod length at

the top storey and 8' rod length plus 14" floor depth (including wall plates) for all other storeys.

4. See design example on p. 39 for use of these tables.
5. Designer is responsible for verifying that the cumulative tension demand forces do not exceed the factored tensile resistance shown. See Step 2 in design example on p. 40.
6. System capacity assumes top plate termination. See p. 34 for details. For bridge block termination, reduce top storey capacity according to cripple wall studs load table on p. 35.
7. 5-storey and 6-storey runs apply only to jurisdictions with Building Code provision for Mid-Rise Wood Frame Construction.

Strong-Rod™ ATS Pre-Engineered Runs

Five-Storey Systems (cont.)

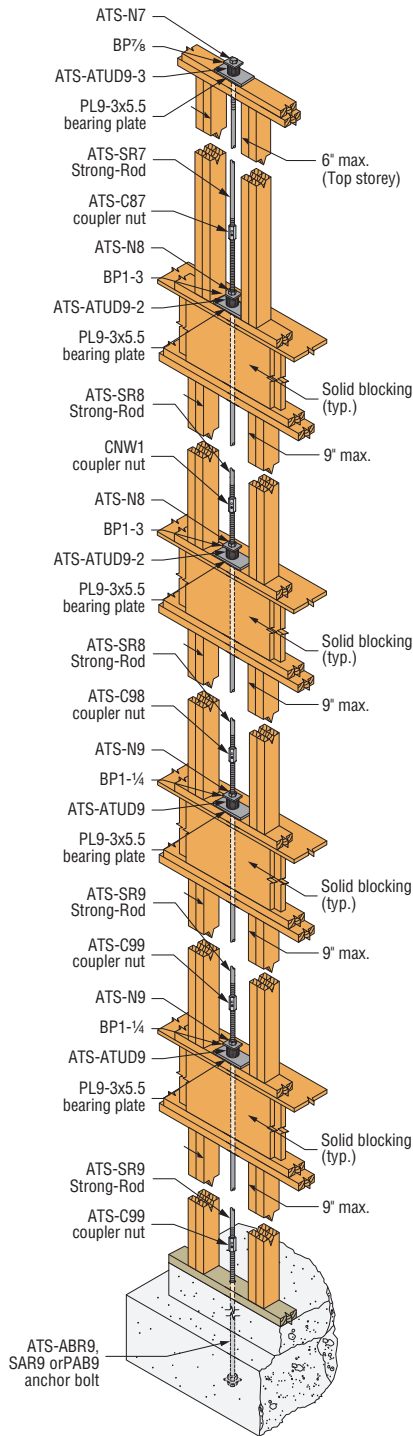

TDS5-1 1/8

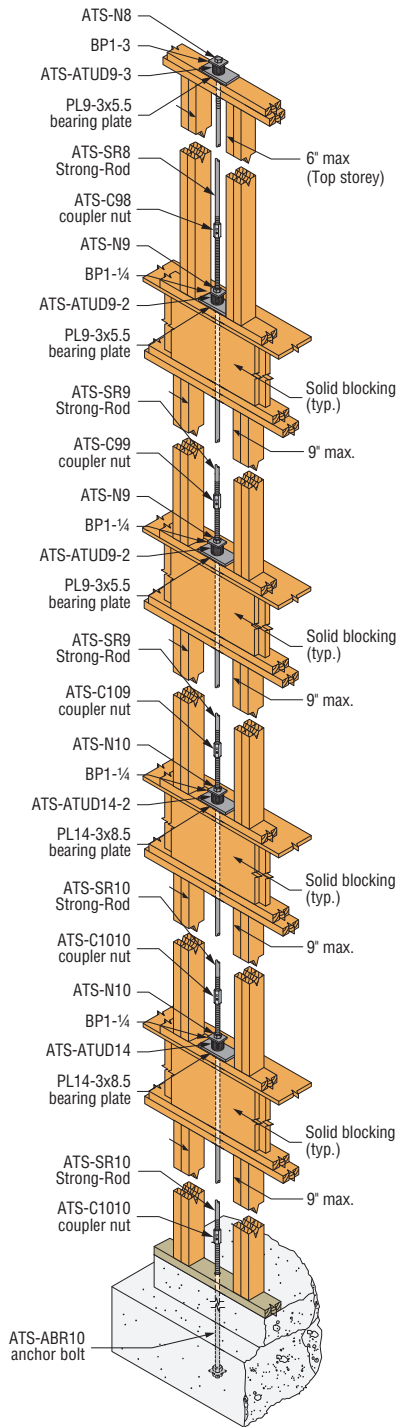

TDS5-1 1/4

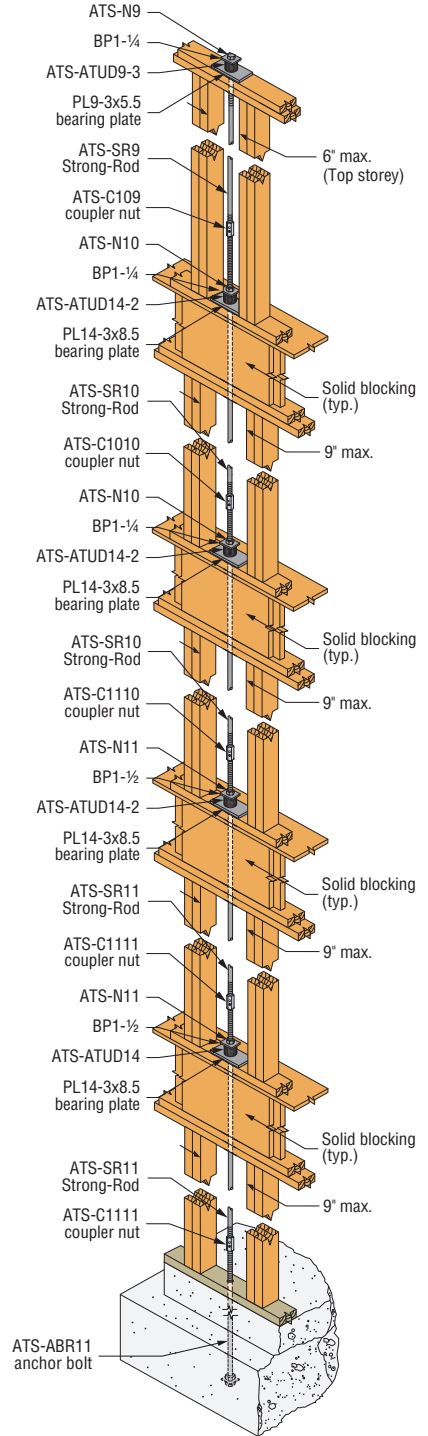

TDS5-1 3/8

Anchorage-to-concrete and foundation design by Designer. For bridge block termination, reduce top-storey capacity as per p. 35.

Strong-Rod™ ATS Pre-Engineered Runs

Five-Storey Systems (cont.)

ATS		TDS5-1½		TDS5-¾H		TDS5-1¼H		
Plates/Studs		D.Fir-L	S-P-F	D.Fir-L	S-P-F	D.Fir-L	S-P-F	
5th Floor	Factored Tensile Resistance, T_r	lb..	14195	12940	14195	14195	14195	14195
		kN	63.23	57.64	63.23	63.23	63.23	63.23
	8' Posts	2x4 framing	(2) 2x4 each side	(2) 2x4 each side	(2) 2x4 each side	(2) 2x4 each side	(2) 2x4 each side	(2) 2x4 each side
		2x6 framing	(1) 2x6 each side	(1) 2x6 each side	(1) 2x6 each side	(1) 2x6 each side	(1) 2x6 each side	(1) 2x6 each side
		2x8 framing	(1) 2x8 each side	(1) 2x8 each side	(1) 2x8 each side	(1) 2x8 each side	(1) 2x8 each side	(1) 2x8 each side
	Incremental Bearing Resistance	lb..	23890	18080	15350	12940	15350	12940
kN		106.41	80.53	68.37	57.64	68.37	57.64	
4th Floor	Factored Tensile Resistance, T_r	lb.	38085	31020	19260	19260	29545	27135
		kN	169.64	138.17	85.79	85.79	131.60	120.87
	8' Posts	2x4 framing	(5) 2x4 each side	(4) 2x4 each side	(3) 2x4 each side	(3) 2x4 each side	(4) 2x4 each side	(4) 2x4 each side
		2x6 framing	(2) 2x6 each side	(3) 2x6 each side	(1) 2x6 each side	(2) 2x6 each side	(2) 2x6 each side	(2) 2x6 each side
		2x8 framing	(2) 2x8 each side	(2) 2x8 each side	(1) 2x8 each side	(1) 2x8 each side	(1) 2x8 each side	(2) 2x8 each side
	Incremental Bearing Resistance	lb.	23890	18080	15350	15350	15350	15350
kN		106.41	80.53	68.37	68.37	68.37	68.37	
3rd Floor	Factored Tensile Resistance, T_r	lb.	48640	48640	37145	37145	41205	41205
		kN	216.66	216.66	165.46	165.46	183.54	183.54
	8' Posts	2x4 framing	(6) 2x4 each side	(6) 2x4 each side	(4) 2x4 each side	(4) 2x4 each side	(5) 2x4 each side	(5) 2x4 each side
		2x6 framing	(3) 2x6 each side	(4) 2x6 each side	(2) 2x6 each side	(3) 2x6 each side	(3) 2x6 each side	(3) 2x6 each side
		2x8 framing	(2) 2x8 each side	(3) 2x8 each side	(2) 2x8 each side	(2) 2x8 each side	(2) 2x8 each side	(3) 2x8 each side
	Incremental Bearing Resistance	lb.	23890	18080	18670	18670	18670	18670
kN		106.41	80.53	83.16	83.16	83.16	83.16	
2nd Floor	Factored Tensile Resistance, T_r	lb.	54795	54795	37145	37145	63565	61155
		kN	244.08	244.08	165.46	165.46	283.14	272.41
	8' Posts	2x4 framing	(6) 2x4 each side	—	(4) 2x4 each side	(5) 2x4 each side	(6) 2x4 each side	—
		2x6 framing	(4) 2x6 each side	(5) 2x6 each side	(2) 2x6 each side	(3) 2x6 each side	(4) 2x6 each side	(4) 2x6 each side
		2x8 framing	(3) 2x8 each side	(3) 2x8 each side	(2) 2x8 each side	(2) 2x8 each side	(3) 2x8 each side	(4) 2x8 each side
	Incremental Bearing Resistance	lb.	23890	18080	18670	18670	18670	18670
kN		106.41	80.53	83.16	83.16	83.16	83.16	
1st Floor	Factored Tensile Resistance, T_r	lb.	54795	54795	37145	37145	63900	63900
		kN	244.08	244.08	165.46	165.46	284.63	284.63
	8' Posts	2x4 framing	(6) 2x4 each side	—	(4) 2x4 each side	(5) 2x4 each side	—	—
		2x6 framing	(4) 2x6 each side	(5) 2x6 each side	(2) 2x6 each side	(3) 2x6 each side	(4) 2x6 each side	(5) 2x6 each side
		2x8 framing	(3) 2x8 each side	(3) 2x8 each side	(2) 2x8 each side	(2) 2x8 each side	(3) 2x8 each side	(4) 2x8 each side

1. Unless specifically requested, anchor bolts are not included in the system runs.
2. Post design is based on the tension capacity of the system. The Designer is responsible for verifying that the wood posts are capable of resisting all required load combinations.
3. Total vertical displacement of each storey, or between restraints, meets the 0.300" (7.6 mm) for regular-strength Strong-Rod runs. High-strength Strong-Rod runs exceed the total vertical displacement limit of 0.300" (7.6 mm) for each storey. The total vertical displacement limit may be exceeded if it can be demonstrated that the shearwall drift limit and deformation compatibility are met when accounting for all sources of vertical displacements. Total vertical displacement of the individual pre-engineered runs assumes 6' rod length at

the top storey and 8' rod length plus 14" floor depth (including wall plates) for all other storeys.

4. See design example on p. 39 for use of these tables.
5. Designer is responsible for verifying that the cumulative tension demand forces do not exceed the factored tensile resistance shown. See Step 2 in design example on p. 40.
6. System capacity assumes top plate termination. See p. 34 for details. For bridge block termination, reduce top storey capacity according to cripple wall studs load table on p. 35.
7. 5-storey and 6-storey runs apply only to jurisdictions with Building Code provision for Mid-Rise Wood Frame Construction.

Five-Storey Systems (cont.)

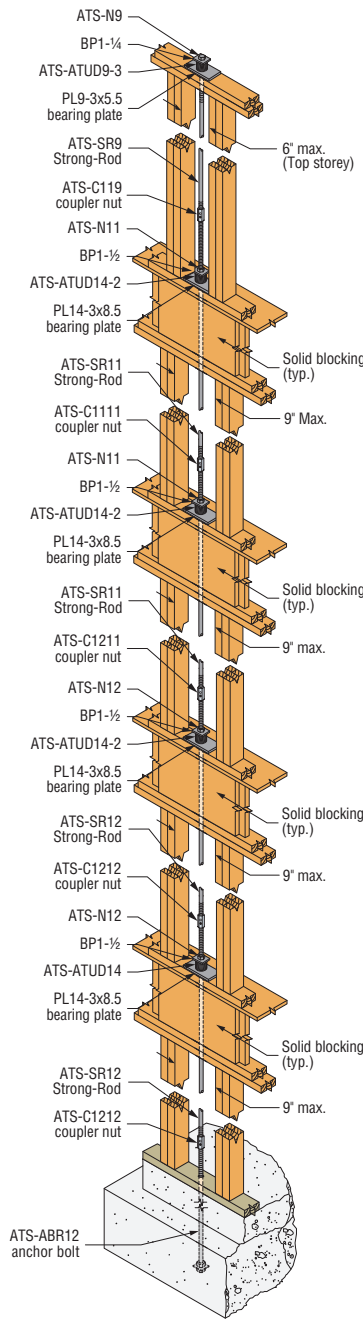

TDS5-1 1/2

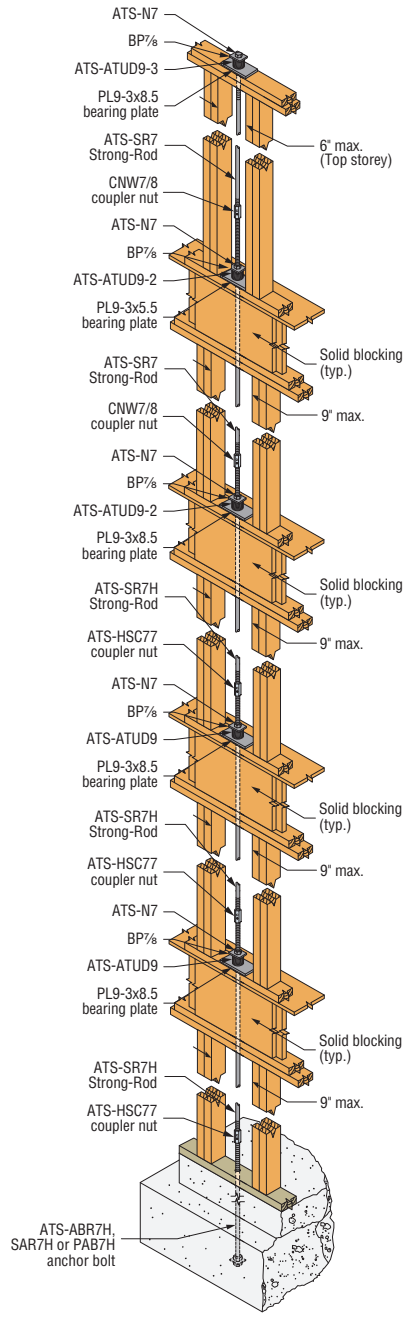

TDS5-7/8H

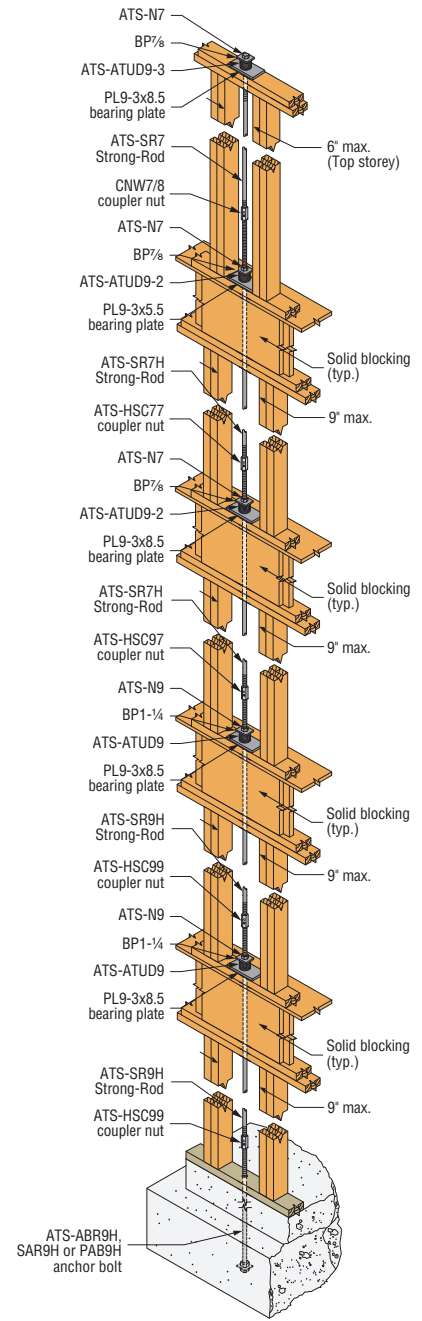

TDS5-1 1/8H

Anchorage-to-concrete and foundation design by Designer. For bridge block termination, reduce top-storey capacity as per p. 35.

Strong-Rod™ ATS Pre-Engineered Runs

Five-Storey Systems (cont.)

ATS			TDS5-1¼H		TDS5-1½H		TDS5-1¾H	
Plates/Studs			D.Fir-L	S-P-F	D.Fir-L	S-P-F	D.Fir-L	S-P-F
5th Floor	Factored Tensile Resistance, T _r	lb.	14195	14195	14195	14195	14195	14195
		kN	63.23	63.23	63.23	63.23	63.23	63.23
	8' Posts	2x4 framing	(2) 2x4 each side	(2) 2x4 each side	—	—	—	—
		2x6 framing	(1) 2x6 each side	(1) 2x6 each side	(1) 2x6 each side	(1) 2x6 each side	(1) 2x6 each side	(1) 2x6 each side
		2x8 framing	(1) 2x8 each side	(1) 2x8 each side	(1) 2x8 each side	(1) 2x8 each side	(1) 2x8 each side	(1) 2x8 each side
	Incremental Bearing Resistance	lb.	15350	12940	27815	21050	27815	21050
		kN	68.37	57.64	123.90	93.76	123.90	93.76
4th Floor	Factored Tensile Resistance, T _r	lb.	29545	27135	42010	35245	42010	35245
		kN	131.60	120.87	187.13	156.99	187.13	156.99
	8' Posts	2x4 framing	(4) 2x4 each side	(4) 2x4 each side	—	—	—	—
		2x6 framing	(2) 2x6 each side	(2) 2x6 each side	(3) 2x6 each side	(3) 2x6 each side	(3) 2x6 each side	(3) 2x6 each side
		2x8 framing	(1) 2x8 each side	(2) 2x8 each side	(2) 2x8 each side	(2) 2x8 each side	(2) 2x8 each side	(2) 2x8 each side
	Incremental Bearing Resistance	lb.	15350	15350	33970	31895	33970	31895
		kN	68.37	68.37	151.31	142.07	151.31	142.07
3rd Floor	Factored Tensile Resistance, T _r	lb.	41205	41205	53850	53850	68190	67140
		kN	183.54	183.54	239.87	239.87	303.74	299.06
	8' Posts	2x4 framing	(5) 2x4 each side	(5) 2x4 each side	—	—	—	—
		2x6 framing	(3) 2x6 each side	(4) 2x6 each side	(4) 2x6 each side	(5) 2x6 each side	(4) 2x6 each side	(5) 2x6 each side
		2x8 framing	(2) 2x8 each side	(3) 2x8 each side	(3) 2x8 each side	(3) 2x8 each side	(3) 2x8 each side	(4) 2x8 each side
	Incremental Bearing Resistance	lb.	18670	18670	33970	31895	33970	31895
		kN	83.16	83.16	151.31	142.07	151.31	142.07
2nd Floor	Factored Tensile Resistance, T _r	lb.	63565	61155	86005	86005	104065	99035
		kN	283.14	272.41	383.10	383.10	463.54	441.14
	8' Posts	2x4 framing	—	—	—	—	—	—
		2x6 framing	(4) 2x6 each side	(5) 2x6 each side	(5) 2x6 each side	—	(6) 2x6 each side	—
		2x8 framing	(3) 2x8 each side	(4) 2x8 each side	(4) 2x8 each side	(5) 2x8 each side	(5) 2x8 each side	(6) 2x8 each side
	Incremental Bearing Resistance	lb.	23890	18080	29275	29275	29275	29275
		kN	106.41	80.53	130.40	130.40	130.40	130.40
1st Floor	Factored Tensile Resistance, T _r	lb.	81155	79235	97150	97150	118085	118085
		kN	361.49	352.94	432.74	432.74	525.99	525.99
	8' Posts	2x4 framing	—	—	—	—	—	—
		2x6 framing	(5) 2x6 each side	(6) 2x6 each side	(6) 2x6 each side	—	—	—
		2x8 framing	(3) 2x8 each side	(4) 2x8 each side	(4) 2x8 each side	(5) 2x8 each side	(5) 2x8 each side	(6) 2x8 each side

1. Unless specifically requested, anchor bolts are not included in the system runs.
2. Post design is based on the tension capacity of the system. The Designer is responsible for verifying that the wood posts are capable of resisting all required load combinations.
3. Total vertical displacement of each storey, or between restraints, meets the 0.300" (7.6 mm) for regular-strength Strong-Rod runs. High-strength Strong-Rod runs exceed the total vertical displacement limit of 0.300" (7.6 mm) for each storey. The total vertical displacement limit may be exceeded if it can be demonstrated that the shearwall drift limit and deformation compatibility are met when accounting for all sources of vertical displacements. Total vertical displacement of the individual pre-engineered runs assumes 6' rod length at

- the top storey and 8' rod length plus 14" floor depth (including wall plates) for all other storeys.
4. See design example on p. 39 for use of these tables.
5. Designer is responsible for verifying that the cumulative tension demand forces do not exceed the factored tensile resistance shown. See Step 2 in design example on p. 40.
6. System capacity assumes top plate termination. See p. 34 for details. For bridge block termination, reduce top storey capacity according to cripple wall studs load table on p. 35.
7. 5-storey and 6-storey runs apply only to jurisdictions with Building Code provision for Mid-Rise Wood Frame Construction.

Five-Storey Systems (cont.)

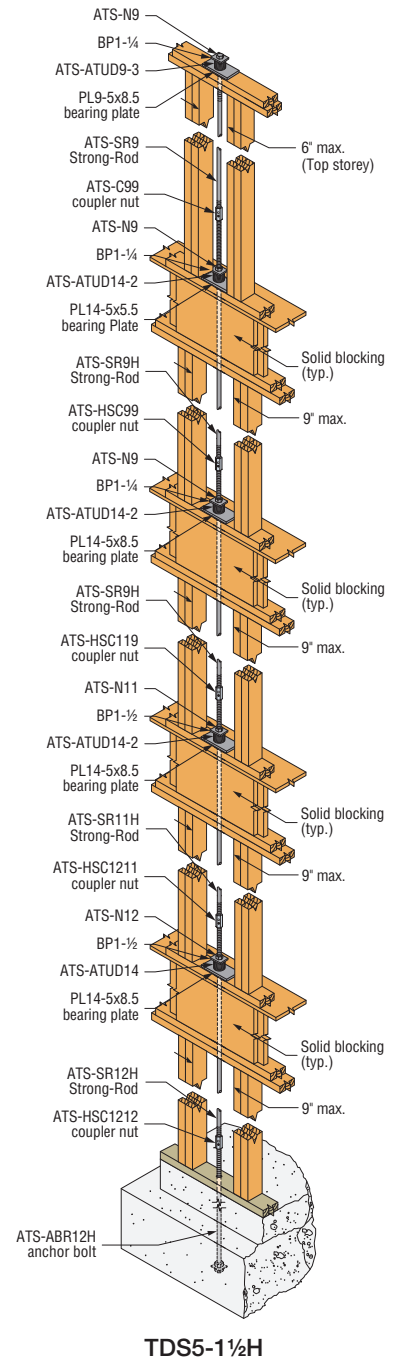
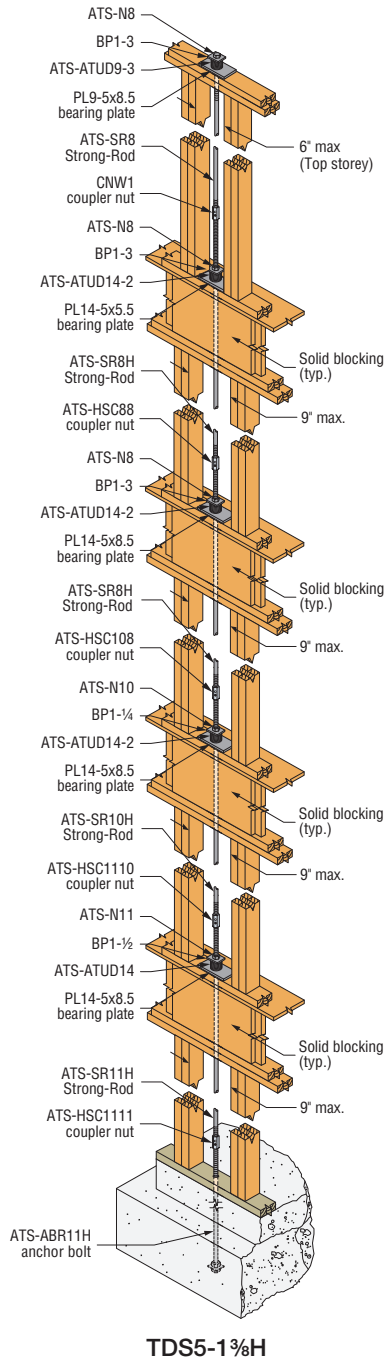
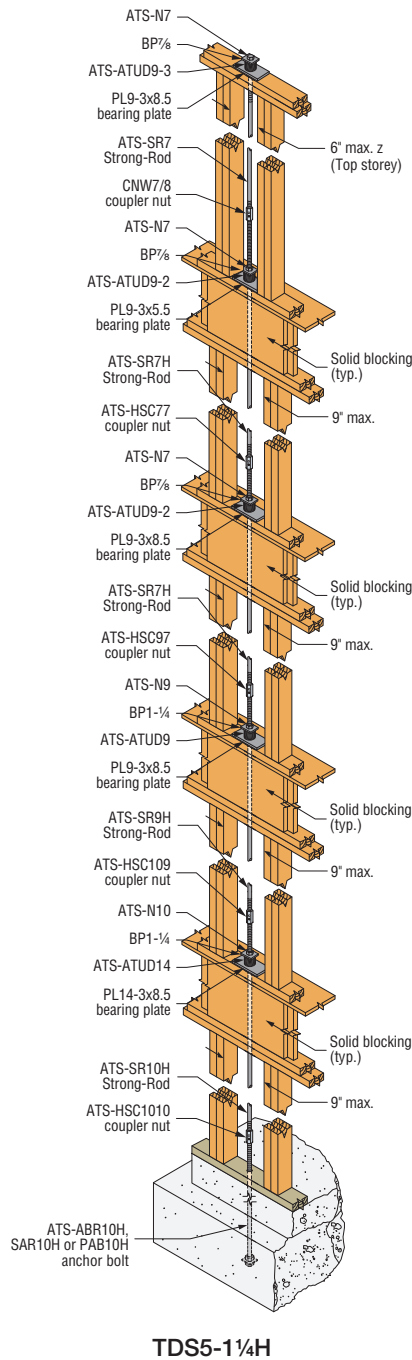

Anchorage-to-concrete and foundation design by Designer. For bridge block termination, reduce top-storey capacity as per p. 35.

Strong-Rod™ ATS Pre-Engineered Runs

Six-Storey Systems

ATS		TDS6-3/4		TDS6-7/8		TDS6-1		
6th Floor	Plates/Studs	D.Fir-L	S-P-F	D.Fir-L	S-P-F	D.Fir-L	S-P-F	
	Factored Tensile Resistance, T_r	lb.	9530	9530	9530	9530	14055	13705
kN		42.45	42.45	42.45	42.45	62.61	61.05	
8' Posts	2x4 framing	(2) 2x4 each side	(2) 2x4 each side	(2) 2x4 each side	(2) 2x4 each side	(2) 2x4 each side	(2) 2x4 each side	
	2x6 framing	(1) 2x6 each side	(1) 2x6 each side	(1) 2x6 each side	(1) 2x6 each side	(1) 2x6 each side	(1) 2x6 each side	
	2x8 framing	(1) 2x8 each side	(1) 2x8 each side	(1) 2x8 each side	(1) 2x8 each side	(1) 2x8 each side	(1) 2x8 each side	
Incremental Bearing Resistance	lb.	9530	9530	9530	9530	14055	13705	
	kN	42.45	42.45	42.45	42.45	62.61	61.05	
5th Floor	Factored Tensile Resistance, T_r	lb.	9530	9530	9530	9530	14055	14055
		kN	42.45	42.45	42.45	42.45	62.61	62.61
8' Posts	2x4 framing	(2) 2x4 each side	(2) 2x4 each side	(2) 2x4 each side	(2) 2x4 each side	(2) 2x4 each side	(2) 2x4 each side	
	2x6 framing	(1) 2x6 each side	(1) 2x6 each side	(1) 2x6 each side	(1) 2x6 each side	(1) 2x6 each side	(1) 2x6 each side	
	2x8 framing	(1) 2x8 each side	(1) 2x8 each side	(1) 2x8 each side	(1) 2x8 each side	(1) 2x8 each side	(1) 2x8 each side	
Incremental Bearing Resistance	lb.	12980	12980	14055	13705	15350	12940	
	kN	57.82	57.82	62.61	61.05	68.37	57.64	
4th Floor	Factored Tensile Resistance, T_r	lb.	12980	12980	14055	14055	19260	19260
		kN	57.82	57.82	62.61	62.61	85.79	85.79
8' Posts	2x4 framing	(2) 2x4 each side	(2) 2x4 each side	(2) 2x4 each side	(2) 2x4 each side	(3) 2x4 each side	(3) 2x4 each side	
	2x6 framing	(1) 2x6 each side	(1) 2x6 each side	(1) 2x6 each side	(1) 2x6 each side	(1) 2x6 each side	(2) 2x6 each side	
	2x8 framing	(1) 2x8 each side	(1) 2x8 each side	(1) 2x8 each side	(1) 2x8 each side	(1) 2x8 each side	(1) 2x8 each side	
Incremental Bearing Resistance	lb.	12980	12980	14055	13705	15350	12940	
	kN	57.82	57.82	62.61	61.05	68.37	57.64	
3rd Floor	Factored Tensile Resistance, T_r	lb.	12980	12980	14055	14055	19260	19260
		kN	57.82	57.82	62.61	62.61	85.79	85.79
8' Posts	2x4 framing	(2) 2x4 each side	(2) 2x4 each side	(2) 2x4 each side	(2) 2x4 each side	(3) 2x4 each side	(3) 2x4 each side	
	2x6 framing	(1) 2x6 each side	(1) 2x6 each side	(1) 2x6 each side	(1) 2x6 each side	(1) 2x6 each side	(2) 2x6 each side	
	2x8 framing	(1) 2x8 each side	(1) 2x8 each side	(1) 2x8 each side	(1) 2x8 each side	(1) 2x8 each side	(1) 2x8 each side	
Incremental Bearing Resistance	lb.	12980	12980	17095	12940	17095	12940	
	kN	57.82	57.82	76.15	57.64	76.15	57.64	
2nd Floor	Factored Tensile Resistance, T_r	lb.	12980	12980	17955	17955	23550	23550
		kN	57.82	57.82	79.98	79.98	104.90	104.90
8' Posts	2x4 framing	(2) 2x4 each side	(2) 2x4 each side	(2) 2x4 each side	(3) 2x4 each side	(3) 2x4 each side	(3) 2x4 each side	
	2x6 framing	(1) 2x6 each side	(1) 2x6 each side	(1) 2x6 each side	(2) 2x6 each side	(2) 2x6 each side	(2) 2x6 each side	
	2x8 framing	(1) 2x8 each side	(1) 2x8 each side	(1) 2x8 each side	(1) 2x8 each side	(1) 2x8 each side	(2) 2x8 each side	
Incremental Bearing Resistance	lb.	12980	12980	17095	12940	17095	12940	
	kN	57.82	57.82	76.15	57.64	76.15	57.64	
1st Floor	Factored Tensile Resistance, T_r	lb.	12980	12980	17955	17955	23550	23550
		kN	57.82	57.82	79.98	79.98	104.90	104.90
8' Posts	2x4 framing	(2) 2x4 each side	(2) 2x4 each side	(2) 2x4 each side	(3) 2x4 each side	(3) 2x4 each side	(3) 2x4 each side	
	2x6 framing	(1) 2x6 each side	(1) 2x6 each side	(1) 2x6 each side	(2) 2x6 each side	(2) 2x6 each side	(2) 2x6 each side	
	2x8 framing	(1) 2x8 each side	(1) 2x8 each side	(1) 2x8 each side	(1) 2x8 each side	(1) 2x8 each side	(2) 2x8 each side	

1. Unless specifically requested, anchor bolts are not included in the system runs.
2. Post design is based on the tension capacity of the system. The Designer is responsible for verifying that the wood posts are capable of resisting all required load combinations.
3. Total vertical displacement of each storey, or between restraints, meets the 0.300" (7.6 mm) for regular-strength Strong-Rod runs. High-strength Strong-Rod runs exceed the total vertical displacement limit of 0.300" (7.6 mm) for each storey. The total vertical displacement limit may be exceeded if it can be demonstrated that the shearwall drift limit and deformation compatibility are met when accounting for all sources of vertical displacements. Total vertical displacement of the individual pre-engineered runs assumes 6' rod length at

- the top storey and 8' rod length plus 14" floor depth (including wall plates) for all other storeys.
4. See design example on p. 39 for use of these tables.
5. Designer is responsible for verifying that the cumulative tension demand forces do not exceed the factored tensile resistance shown. See Step 2 in design example on p. 40.
6. System capacity assumes top plate termination. See p. 34 for details. For bridge block termination, reduce top storey capacity according to cripple wall studs load table on p. 35.
7. 5-storey and 6-storey runs apply only to jurisdictions with Building Code provision for Mid-Rise Wood Frame Construction.

Six-Storey Systems (cont.)

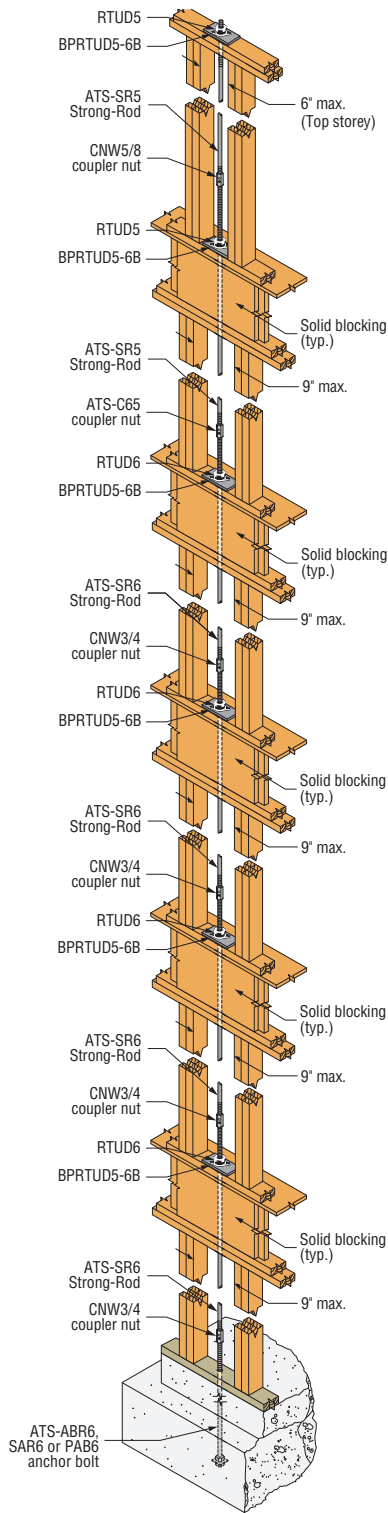

TDS6- $\frac{3}{4}$

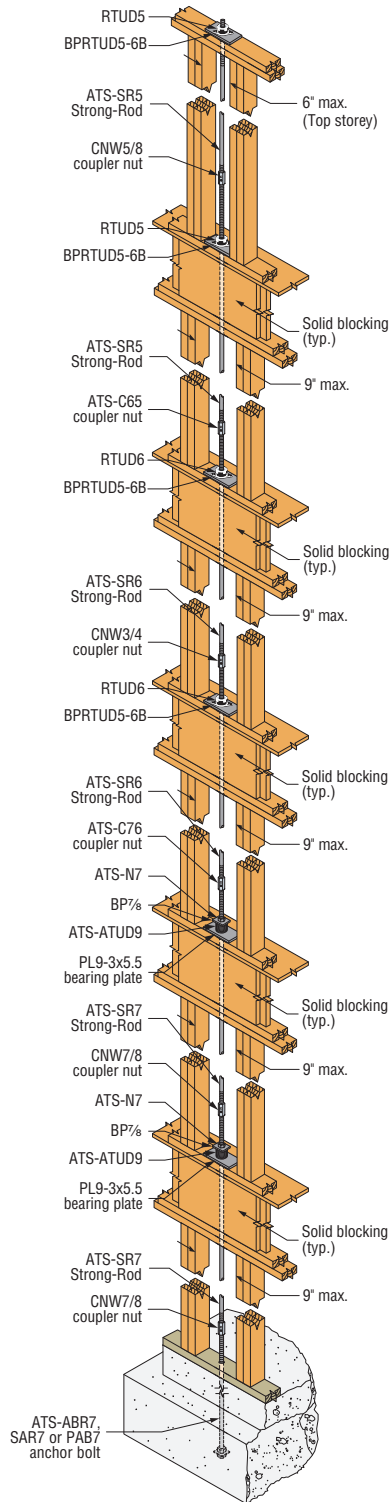

TDS6- $\frac{7}{8}$

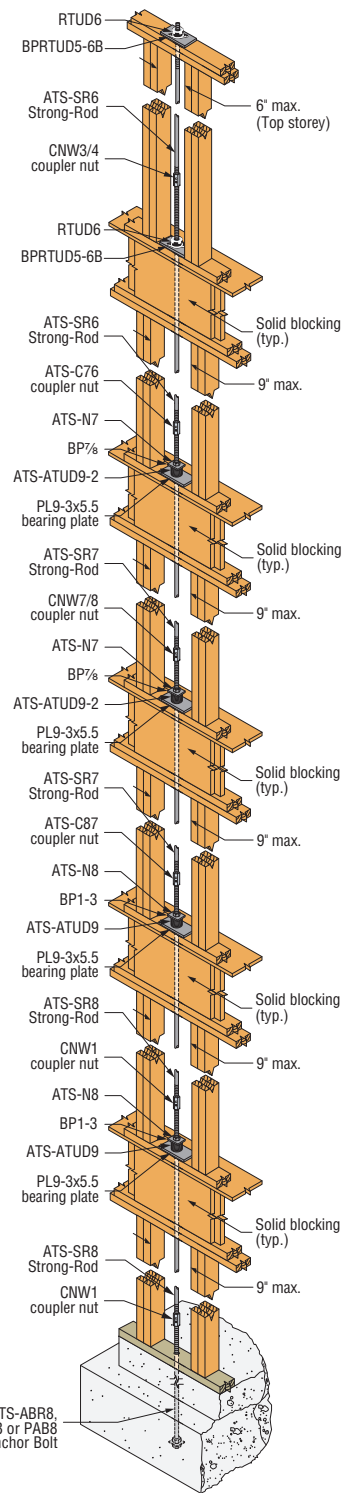

TDS6-1

Anchorage-to-concrete and foundation design by Designer. For bridge block termination, reduce top-storey capacity as per p. 35.

Six-Storey Systems (cont.)

ATS		TDS6-1½		TDS6-1¼		TDS6-1¾		
6th Floor	Plates/Studs	D.Fir-L	S-P-F	D.Fir-L	S-P-F	D.Fir-L	S-P-F	
	Factored Tensile Resistance, T_r	lb.	14195	12940	14195	12940	14195	12940
kN		63.23	57.64	63.23	57.64	63.23	57.64	
8' Posts	2x4 framing	(2) 2x4 each side	(2) 2x4 each side	(2) 2x4 each side	(2) 2x4 each side	(2) 2x4 each side	(2) 2x4 each side	
	2x6 framing	(1) 2x6 each side	(1) 2x6 each side	(1) 2x6 each side	(1) 2x6 each side	(1) 2x6 each side	(1) 2x6 each side	
	2x8 framing	(1) 2x8 each side	(1) 2x8 each side	(1) 2x8 each side	(1) 2x8 each side	(1) 2x8 each side	(1) 2x8 each side	
Incremental Bearing Resistance	lb.	14195	12940	14195	12940	14195	12940	
	kN	63.23	57.64	63.23	57.64	63.23	57.64	
5th Floor	Factored Tensile Resistance, T_r	lb.	19260	19260	25170	25170	28390	25880
	kN	85.79	85.79	112.12	112.12	126.46	115.28	
8' Posts	2x4 framing	(3) 2x4 each side	(3) 2x4 each side	(3) 2x4 each side	(3) 2x4 each side	(3) 2x4 each side	(4) 2x4 each side	
	2x6 framing	(1) 2x6 each side	(2) 2x6 each side	(2) 2x6 each side	(2) 2x6 each side	(2) 2x6 each side	(2) 2x6 each side	
	2x8 framing	(1) 2x8 each side	(1) 2x8 each side	(1) 2x8 each side	(2) 2x8 each side	(1) 2x8 each side	(2) 2x8 each side	
Incremental Bearing Resistance	lb.	15350	12940	15350	12940	23890	18080	
	kN	68.37	57.64	68.37	57.64	106.41	80.53	
4th Floor	Factored Tensile Resistance, T_r	lb.	25170	25170	31870	31870	40195	40195
	kN	112.12	112.12	141.96	141.96	179.04	179.04	
8' Posts	2x4 framing	(3) 2x4 each side	(3) 2x4 each side	(4) 2x4 each side	(4) 2x4 each side	(5) 2x4 each side	(5) 2x4 each side	
	2x6 framing	(2) 2x6 each side	(2) 2x6 each side	(2) 2x6 each side	(3) 2x6 each side	(3) 2x6 each side	(3) 2x6 each side	
	2x8 framing	(1) 2x8 each side	(2) 2x8 each side	(2) 2x8 each side	(2) 2x8 each side	(2) 2x8 each side	(2) 2x8 each side	
Incremental Bearing Resistance	lb.	15350	12940	15350	12940	23890	18080	
	kN	68.37	57.64	68.37	57.64	106.41	80.53	
3rd Floor	Factored Tensile Resistance, T_r	lb.	25170	25170	31870	31870	40195	40195
	kN	112.12	112.12	141.96	141.96	179.04	179.04	
8' Posts	2x4 framing	(3) 2x4 each side	(3) 2x4 each side	(4) 2x4 each side	(4) 2x4 each side	(4) 2x4 each side	(5) 2x4 each side	
	2x6 framing	(2) 2x6 each side	(2) 2x6 each side	(2) 2x6 each side	(3) 2x6 each side	(2) 2x6 each side	(3) 2x6 each side	
	2x8 framing	(1) 2x8 each side	(2) 2x8 each side	(2) 2x8 each side	(2) 2x8 each side	(2) 2x8 each side	(2) 2x8 each side	
Incremental Bearing Resistance	lb.	17095	12940	23890	18080	23890	18080	
	kN	76.15	57.64	106.41	80.53	106.41	80.53	
2nd Floor	Factored Tensile Resistance, T_r	lb.	29650	29650	37655	37655	45080	45080
	kN	132.07	132.07	167.73	167.73	200.80	200.80	
8' Posts	2x4 framing	(4) 2x4 each side	(4) 2x4 each side	(4) 2x4 each side	(5) 2x4 each side	(5) 2x4 each side	(6) 2x4 each side	
	2x6 framing	(2) 2x6 each side	(3) 2x6 each side	(2) 2x6 each side	(3) 2x6 each side	(3) 2x6 each side	(4) 2x6 each side	
	2x8 framing	(1) 2x8 each side	(2) 2x8 each side	(2) 2x8 each side	(2) 2x8 each side	(2) 2x8 each side	(3) 2x8 each side	
Incremental Bearing Resistance	lb.	17095	12940	23890	18080	23890	18080	
	kN	76.15	57.64	106.41	80.53	106.41	80.53	
1st Floor	Factored Tensile Resistance, T_r	lb.	29650	29650	37655	37655	45080	45080
	kN	132.07	132.07	167.73	167.73	200.80	200.80	
8' Posts	2x4 framing	(4) 2x4 each side	(4) 2x4 each side	(4) 2x4 each side	(5) 2x4 each side	(5) 2x4 each side	(6) 2x4 each side	
	2x6 framing	(2) 2x6 each side	(3) 2x6 each side	(2) 2x6 each side	(3) 2x6 each side	(3) 2x6 each side	(4) 2x6 each side	
	2x8 framing	(1) 2x8 each side	(2) 2x8 each side	(2) 2x8 each side	(2) 2x8 each side	(2) 2x8 each side	(3) 2x8 each side	

1. Unless specifically requested, anchor bolts are not included in the system runs.
2. Post design is based on the tension capacity of the system. The Designer is responsible for verifying that the wood posts are capable of resisting all required load combinations.
3. Total vertical displacement of each storey, or between restraints, meets the 0.300" (7.6 mm) for regular-strength Strong-Rod runs. High-strength Strong-Rod runs exceed the total vertical displacement limit of 0.300" (7.6 mm) for each storey. The total vertical displacement limit may be exceeded if it can be demonstrated that the shear wall drift limit and deformation compatibility are met when accounting for all sources of vertical displacements. Total vertical displacement of the individual pre-engineered runs assumes 6' rod length at

- the top storey and 8' rod length plus 14" floor depth (including wall plates) for all other storeys.
4. See design example on p. 39 for use of these tables.
5. Designer is responsible for verifying that the cumulative tension demand forces do not exceed the factored tensile resistance shown. See Step 2 in design example on p. 40.
6. System capacity assumes top plate termination. See p. 34 for details. For bridge block termination, reduce top storey capacity according to cripple wall studs load table on p. 35.
7. 5-storey and 6-storey runs apply only to jurisdictions with Building Code provision for Mid-Rise Wood Frame Construction.

Strong-Rod™ ATS Pre-Engineered Runs

Six-Storey Systems (cont.)

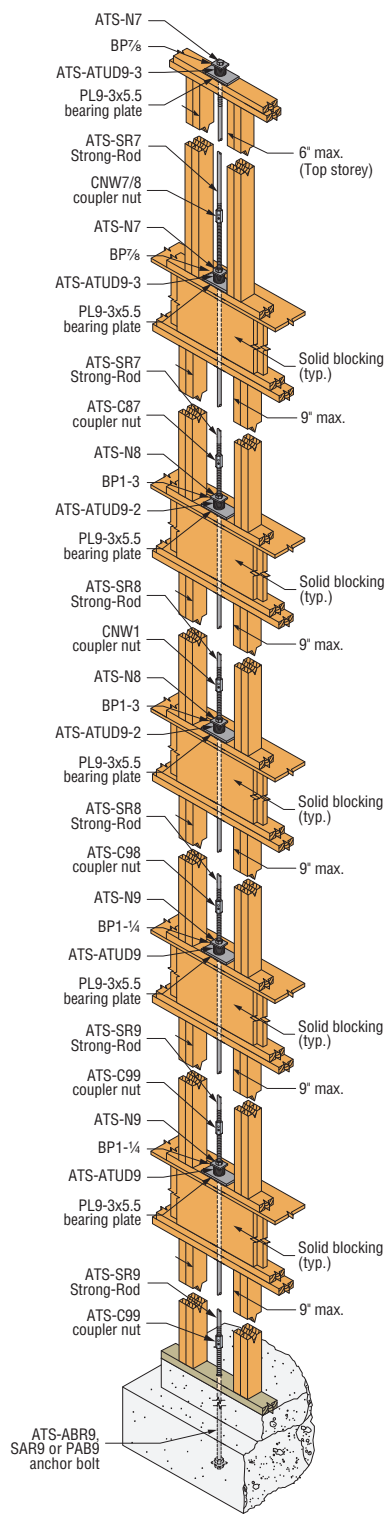

TDS6-1 1/2

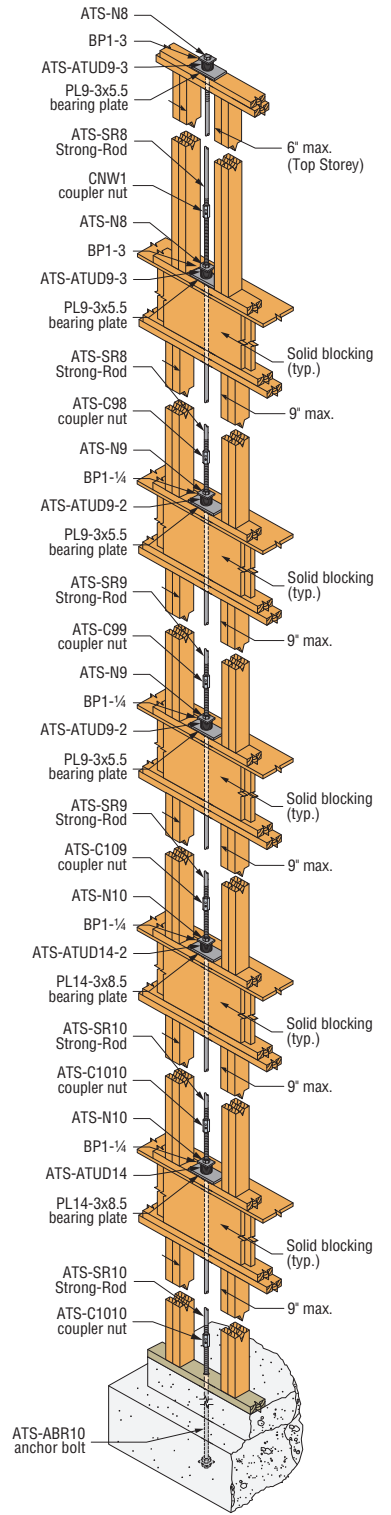

TDS6-1 1/4

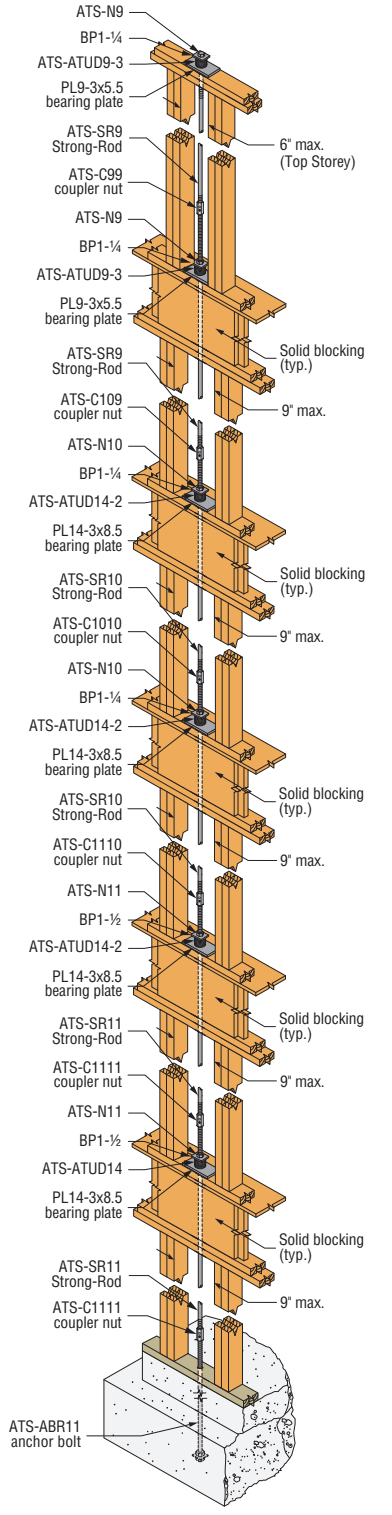

TDS6-1 1/8

Anchorage-to-concrete and foundation design by Designer. For bridge block termination, reduce top-storey capacity as per p. 35.

Strong-Rod™ ATS Pre-Engineered Runs

Six-Storey Systems (cont.)

ATS		TDS6-1½		TDS6-¾H		TDS6-1¼H		
6th Floor	Plates/Studs	D.Fir-L	S-P-F	D.Fir-L	S-P-F	D.Fir-L	S-P-F	
	Factored Tensile Resistance, T_r	lb.	14195	12940	14195	14195	14195	14195
kN		63.23	57.64	63.23	63.23	63.23	63.23	
8' Posts	2x4 framing	(2) 2x4 each side	(2) 2x4 each side	(2) 2x4 each side	(2) 2x4 each side	(2) 2x4 each side	(2) 2x4 each side	
	2x6 framing	(1) 2x6 each side	(1) 2x6 each side	(1) 2x6 each side	(1) 2x6 each side	(1) 2x6 each side	(1) 2x6 each side	
	2x8 framing	(1) 2x8 each side	(1) 2x8 each side	(1) 2x8 each side	(1) 2x8 each side	(1) 2x8 each side	(1) 2x8 each side	
Incremental Bearing Resistance	lb.	14195	12940	14195	12940	14195	12940	
	kN	63.23	57.64	63.23	57.64	63.23	57.64	
5th Floor	Factored Tensile Resistance, T_r	lb.	28390	25880	19260	19260	19260	19260
		kN	126.46	115.28	85.79	85.79	85.79	85.79
8' Posts	2x4 framing	(3) 2x4 each side	(3) 2x4 each side	(3) 2x4 each side	(3) 2x4 each side	(3) 2x4 each side	(3) 2x4 each side	
	2x6 framing	(1) 2x6 each side	(2) 2x6 each side	(1) 2x6 each side	(2) 2x6 each side	(1) 2x6 each side	(2) 2x6 each side	
	2x8 framing	(1) 2x8 each side	(2) 2x8 each side	(1) 2x8 each side	(1) 2x8 each side	(1) 2x8 each side	(1) 2x8 each side	
Incremental Bearing Resistance	lb.	23890	18080	15350	15350	15350	15350	
	kN	106.41	80.53	68.37	68.37	68.37	68.37	
4th Floor	Factored Tensile Resistance, T_r	lb.	48640	43960	37145	37145	41205	41205
		kN	216.66	195.81	165.46	165.46	183.54	183.54
8' Posts	2x4 framing	(4) 2x4 each side	(5) 2x4 each side	(4) 2x4 each side	(5) 2x4 each side	(5) 2x4 each side	(5) 2x4 each side	
	2x6 framing	(2) 2x6 each side	(3) 2x6 each side	(2) 2x6 each side	(3) 2x6 each side	(3) 2x6 each side	(4) 2x6 each side	
	2x8 framing	(2) 2x8 each side	(3) 2x8 each side	(2) 2x8 each side	(2) 2x8 each side	(2) 2x8 each side	(3) 2x8 each side	
Incremental Bearing Resistance	lb.	23890	18080	15350	15350	15350	15350	
	kN	106.41	80.53	68.37	68.37	68.37	68.37	
3rd Floor	Factored Tensile Resistance, T_r	lb.	48640	48640	37145	37145	41205	41205
		kN	216.66	216.66	165.46	165.46	183.54	183.54
8' Posts	2x4 framing	(4) 2x4 each side	(5) 2x4 each side	(4) 2x4 each side	(5) 2x4 each side	(5) 2x4 each side	(5) 2x4 each side	
	2x6 framing	(2) 2x6 each side	(3) 2x6 each side	(2) 2x6 each side	(3) 2x6 each side	(3) 2x6 each side	(4) 2x6 each side	
	2x8 framing	(2) 2x8 each side	(3) 2x8 each side	(2) 2x8 each side	(2) 2x8 each side	(2) 2x8 each side	(3) 2x8 each side	
Incremental Bearing Resistance	lb.	23890	18080	18670	18670	18670	18670	
	kN	106.41	80.53	83.16	83.16	83.16	83.16	
2nd Floor	Factored Tensile Resistance, T_r	lb.	54795	54795	37145	37145	63900	63900
		kN	244.08	244.08	165.46	165.46	284.63	284.63
8' Posts	2x4 framing	(4) 2x4 each side	(5) 2x4 each side	(4) 2x4 each side	(5) 2x4 each side	—	—	
	2x6 framing	(4) 2x6 each side	(5) 2x6 each side	(2) 2x6 each side	(3) 2x6 each side	(4) 2x6 each side	(5) 2x6 each side	
	2x8 framing	(3) 2x8 each side	(3) 2x8 each side	(2) 2x8 each side	(2) 2x8 each side	(3) 2x8 each side	(4) 2x8 each side	
Incremental Bearing Resistance	lb.	23890	18080	18670	18670	18670	18670	
	kN	106.41	80.53	83.16	83.16	83.16	83.16	
1st Floor	Factored Tensile Resistance, T_r	lb.	54795	54795	37145	37145	63900	63900
		kN	244.08	244.08	165.46	165.46	284.63	284.63
8' Posts	2x4 framing	(4) 2x4 each side	(5) 2x4 each side	(4) 2x4 each side	(5) 2x4 each side	—	—	
	2x6 framing	(2) 2x6 each side	(3) 2x6 each side	(2) 2x6 each side	(3) 2x6 each side	(4) 2x6 each side	(5) 2x6 each side	
	2x8 framing	(3) 2x8 each side	(3) 2x8 each side	(2) 2x8 each side	(2) 2x8 each side	(3) 2x8 each side	(4) 2x8 each side	

1. Unless specifically requested, anchor bolts are not included in the system runs.
2. Post design is based on the tension capacity of the system. The Designer is responsible for verifying that the wood posts are capable of resisting all required load combinations.
3. Total vertical displacement of each storey, or between restraints, meets the 0.300" (7.6 mm) for regular-strength Strong-Rod runs. High-strength Strong-Rod runs exceed the total vertical displacement limit of 0.300" (7.6 mm) for each storey. The total vertical displacement limit may be exceeded if it can be demonstrated that the shearwall drift limit and deformation compatibility are met when accounting for all sources of vertical displacements. Total vertical displacement of the individual pre-engineered runs assumes 6' rod length at

- the top storey and 8' rod length plus 14" floor depth (including wall plates) for all other storeys.
4. See design example on p. 39 for use of these tables.
5. Designer is responsible for verifying that the cumulative tension demand forces do not exceed the factored tensile resistance shown. See Step 2 in design example on p. 40.
6. System capacity assumes top plate termination. See p. 34 for details. For bridge block termination, reduce top storey capacity according to cripple wall studs load table on p. 35.
7. 5-storey and 6-storey runs apply only to jurisdictions with Building Code provision for Mid-Rise Wood Frame Construction.

Six-Storey Systems (cont.)

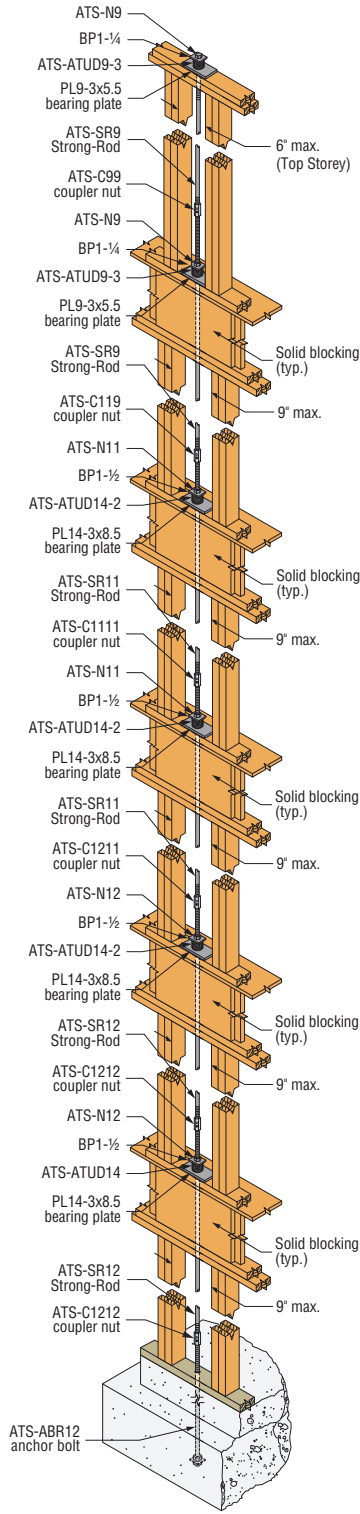

TDS6-1 1/2

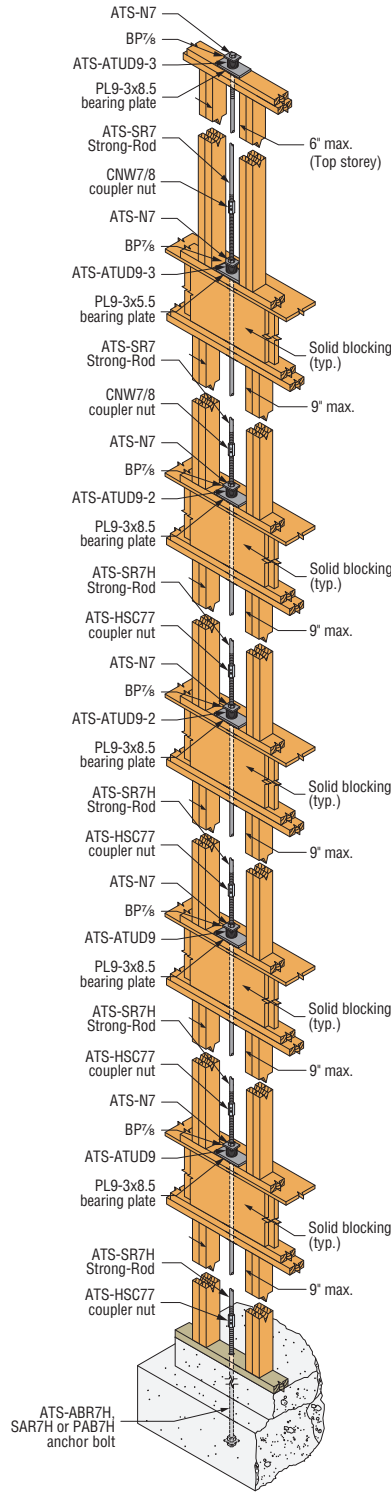

TDS6-7/8H

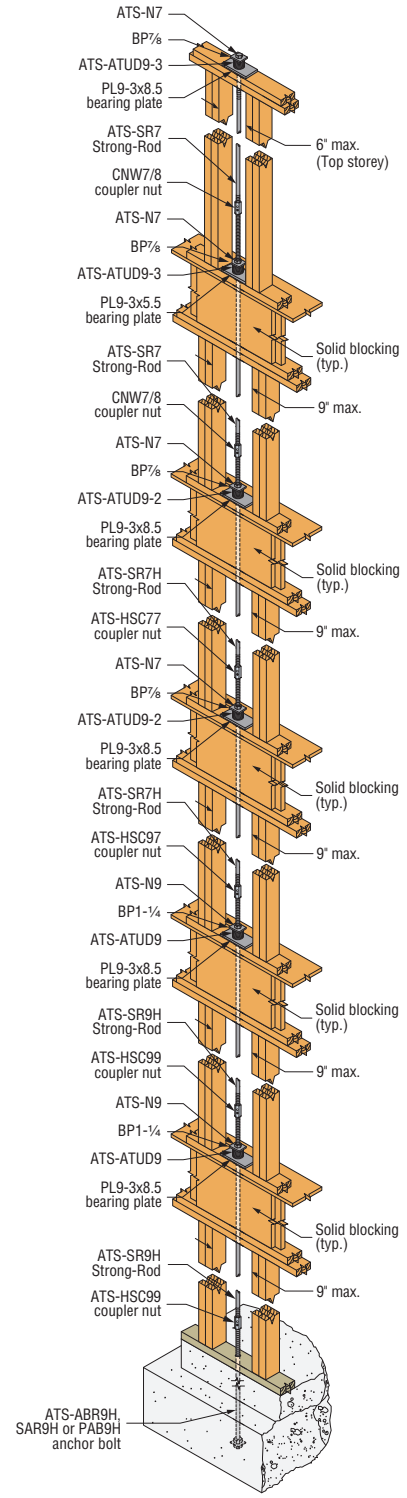

TDS6-1 1/8H

Anchorage-to-concrete and foundation design by Designer. For bridge block termination, reduce top-storey capacity as per p. 35.

Strong-Rod™ ATS Pre-Engineered Runs

Six-Storey Systems (cont.)

ATS		TDS6-1¼H		TDS6-1⅝H		TDS6-1½H		
6th Floor	Plates/Studs	D.Fir-L	S-P-F	D.Fir-L	S-P-F	D.Fir-L	S-P-F	
	Factored Tensile Resistance, T_r	lb.	14195	14195	14195	14195	14195	14195
kN		63.23	63.23	63.23	63.23	63.23	63.23	
8' Posts	2x4 framing	(2) 2x4 each side	(2) 2x4 each side	(2) 2x4 each side	(2) 2x4 each side	(2) 2x4 each side	(2) 2x4 each side	
	2x6 framing	(1) 2x6 each side	(1) 2x6 each side	(1) 2x6 each side	(1) 2x6 each side	(1) 2x6 each side	(1) 2x6 each side	
	2x8 framing	(1) 2x8 each side	(1) 2x8 each side	(1) 2x8 each side	(1) 2x8 each side	(1) 2x8 each side	(1) 2x8 each side	
Incremental Bearing Resistance	lb.	14195	12940	14195	14195	14195	14195	
	kN	63.23	57.64	63.23	63.23	63.23	63.23	
5th Floor	Factored Tensile Resistance, T_r	lb.	19260	19260	25170	25170	28390	28390
	kN	85.79	85.79	112.12	112.12	126.46	126.46	
8' Posts	2x4 framing	(3) 2x4 each side	(3) 2x4 each side	(3) 2x4 each side	(3) 2x4 each side	(3) 2x4 each side	(3) 2x4 each side	
	2x6 framing	(1) 2x6 each side	(2) 2x6 each side	(2) 2x6 each side	(2) 2x6 each side	(2) 2x6 each side	(2) 2x6 each side	
	2x8 framing	(1) 2x8 each side	(1) 2x8 each side	(1) 2x8 each side	(2) 2x8 each side	(1) 2x8 each side	(2) 2x8 each side	
Incremental Bearing Resistance	lb.	15350	15350	15350	15350	33970	31895	
	kN	68.37	68.37	68.37	68.37	151.31	142.07	
4th Floor	Factored Tensile Resistance, T_r	lb.	41205	41205	43740	43740	62360	60285
	kN	183.54	183.54	194.83	194.83	277.77	268.53	
8' Posts	2x4 framing	(5) 2x4 each side	(5) 2x4 each side	(5) 2x4 each side	(6) 2x4 each side	(5) 2x4 each side	(6) 2x4 each side	
	2x6 framing	(3) 2x6 each side	(4) 2x6 each side	(3) 2x6 each side	(4) 2x6 each side	(3) 2x6 each side	(4) 2x6 each side	
	2x8 framing	(2) 2x8 each side	(3) 2x8 each side	(2) 2x8 each side	(3) 2x8 each side	(2) 2x8 each side	(3) 2x8 each side	
Incremental Bearing Resistance	lb.	15350	15350	15350	15350	33970	31895	
	kN	68.37	68.37	68.37	68.37	151.31	142.07	
3rd Floor	Factored Tensile Resistance, T_r	lb.	41205	41205	53850	53850	86005	86005
	kN	183.54	183.54	239.87	239.87	383.10	383.10	
8' Posts	2x4 framing	(5) 2x4 each side	(5) 2x4 each side	(5) 2x4 each side	—	(5) 2x4 each side	—	
	2x6 framing	(3) 2x6 each side	(4) 2x6 each side	(4) 2x6 each side	(5) 2x6 each side	(4) 2x6 each side	(5) 2x6 each side	
	2x8 framing	(2) 2x8 each side	(3) 2x8 each side	(3) 2x8 each side	(3) 2x8 each side	(4) 2x8 each side	(4) 2x8 each side	
Incremental Bearing Resistance	lb.	18670	18670	33970	31895	33970	31895	
	kN	83.16	83.16	151.31	142.07	151.31	142.07	
2nd Floor	Factored Tensile Resistance, T_r	lb.	68190	68190	86005	86005	118085	118085
	kN	303.74	303.74	383.10	383.10	525.99	525.99	
8' Posts	2x4 framing	—	—	—	—	—	—	
	2x6 framing	(4) 2x6 each side	(6) 2x6 each side	(5) 2x6 each side	(6) 2x6 each side	(5) 2x6 each side	(6) 2x6 each side	
	2x8 framing	(3) 2x8 each side	(4) 2x8 each side	(4) 2x8 each side	(5) 2x8 each side	(5) 2x8 each side	(5) 2x8 each side	
Incremental Bearing Resistance	lb.	23890	18080	29275	29275	29275	29275	
	kN	106.41	80.53	130.40	130.40	130.40	130.40	
1st Floor	Factored Tensile Resistance, T_r	lb.	81155	81155	97150	97150	118085	118085
	kN	361.49	361.49	432.74	432.74	525.99	525.99	
8' Posts	2x4 framing	—	—	—	—	—	—	
	2x6 framing	(5) 2x6 each side	(6) 2x6 each side	(6) 2x6 each side	—	(6) 2x6 each side	—	
	2x8 framing	(3) 2x8 each side	(4) 2x8 each side	(4) 2x8 each side	(5) 2x8 each side	(5) 2x8 each side	(5) 2x8 each side	

1. Unless specifically requested, anchor bolts are not included in the system runs.
2. Post design is based on the tension capacity of the system. The Designer is responsible for verifying that the wood posts are capable of resisting all required load combinations.
3. Total vertical displacement of each storey, or between restraints, meets the 0.300" (7.6 mm) for regular-strength Strong-Rod runs. High-strength Strong-Rod runs exceed the total vertical displacement limit of 0.300" (7.6 mm) for each storey. The total vertical displacement limit may be exceeded if it can be demonstrated that the shearwall drift limit and deformation compatibility are met when accounting for all sources of vertical displacements. Total vertical displacement of the individual pre-engineered runs assumes 6' rod length at

- the top storey and 8' rod length plus 14" floor depth (including wall plates) for all other storeys.
4. See design example on p. 39 for use of these tables.
5. Designer is responsible for verifying that the cumulative tension demand forces do not exceed the factored tensile resistance shown. See Step 2 in design example on p. 40.
6. System capacity assumes top plate termination. See p. 34 for details. For bridge block termination, reduce top storey capacity according to cripple wall studs load table on p. 35.
7. 5-storey and 6-storey runs apply only to jurisdictions with Building Code provision for Mid-Rise Wood Frame Construction.

Six-Storey Systems (cont.)

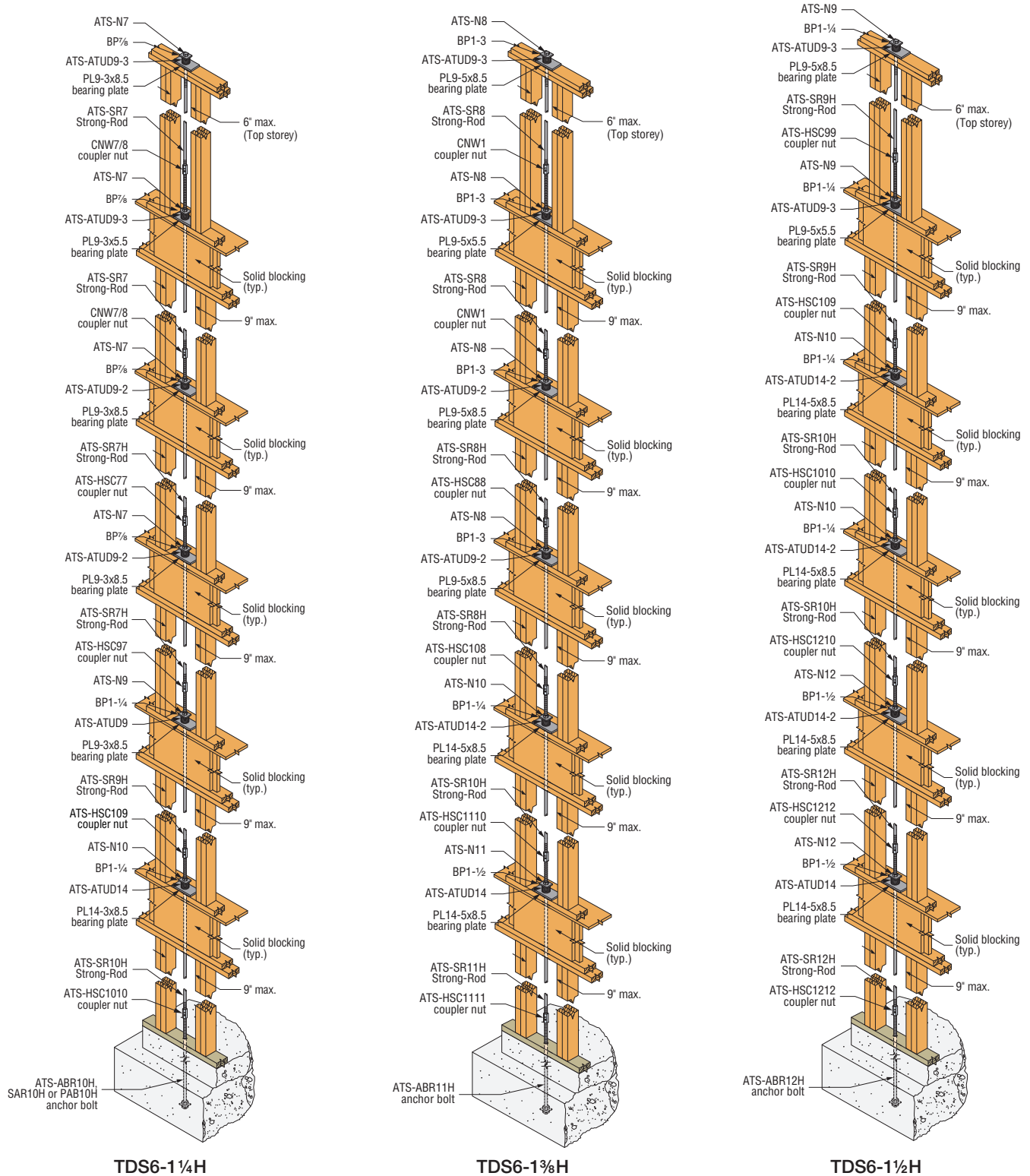

Anchorage-to-concrete and foundation design by Designer. For bridge block termination, reduce top-storey capacity as per p. 35.

Strong-Rod™ ATS Run Termination Details

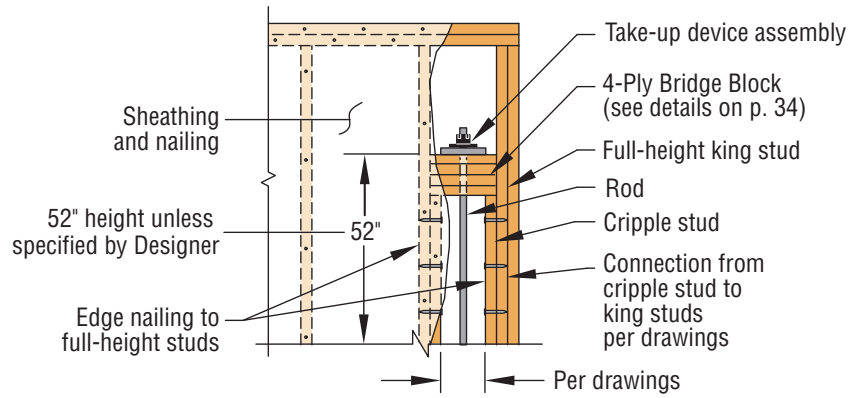

Bridge Block Detail

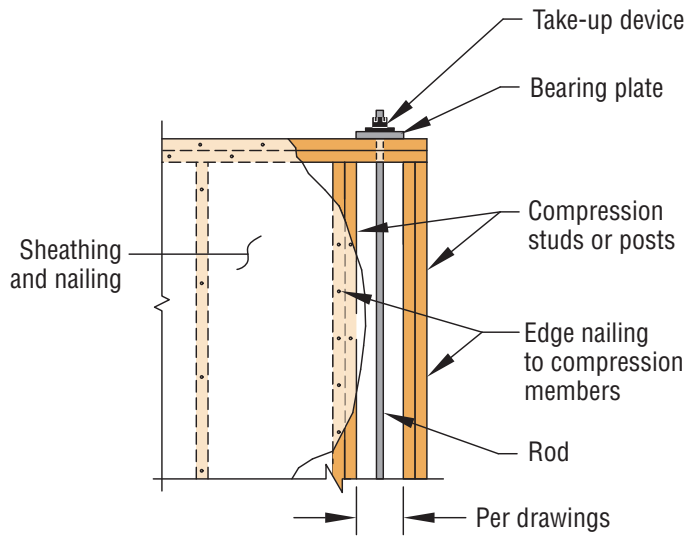

Top Plate Detail

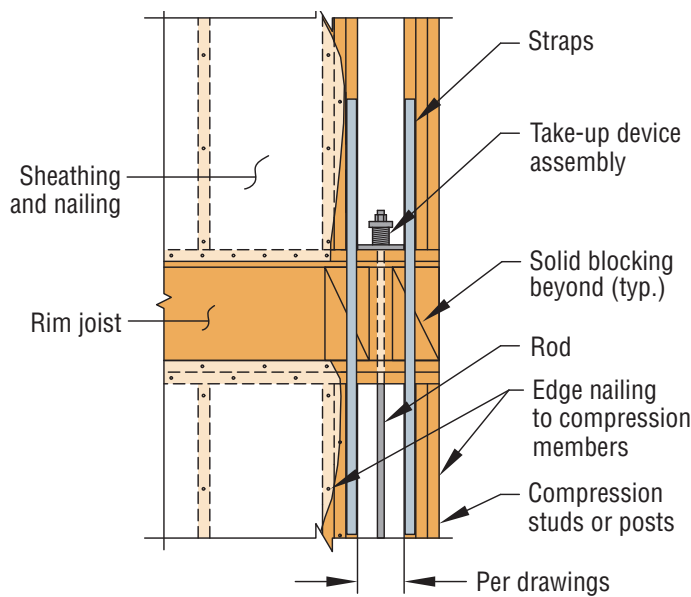

Strap Detail

Strong-Rod™ ATS Run Start Details

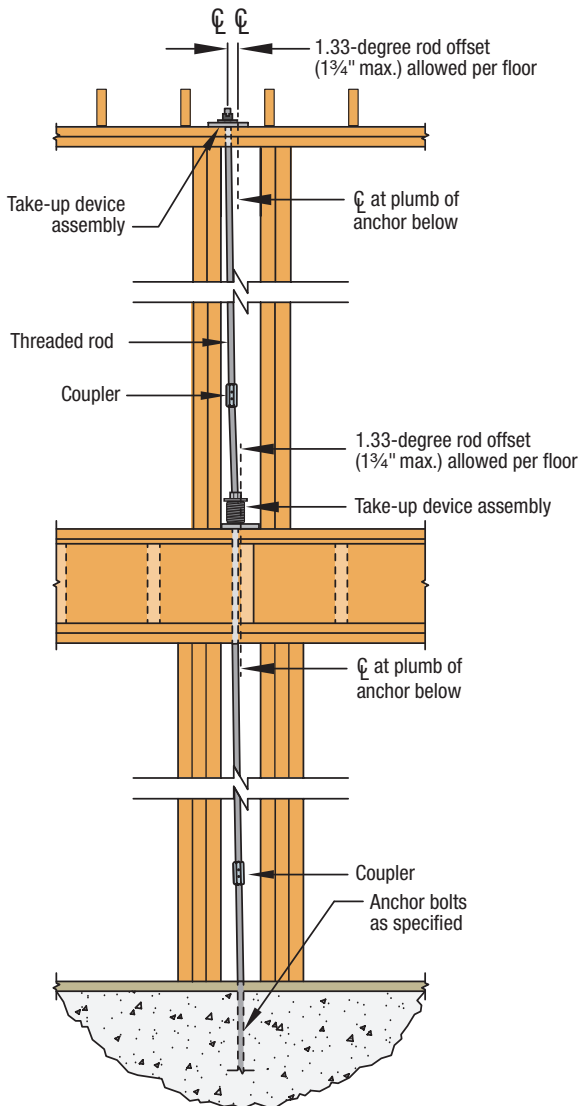

Rod Offset Detail

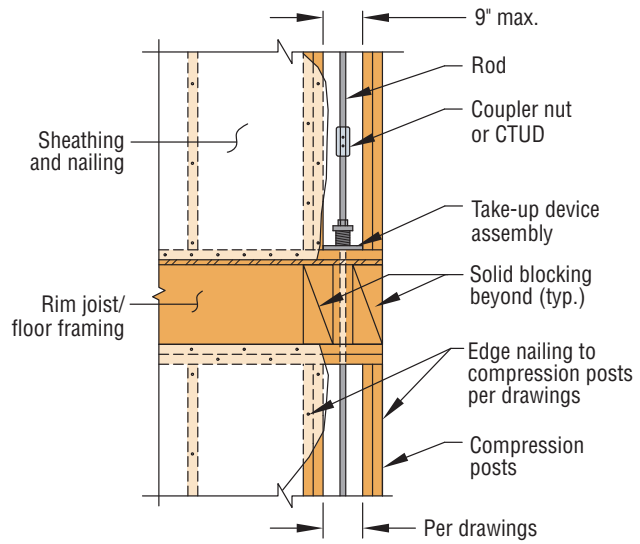

Mid Floor Detail

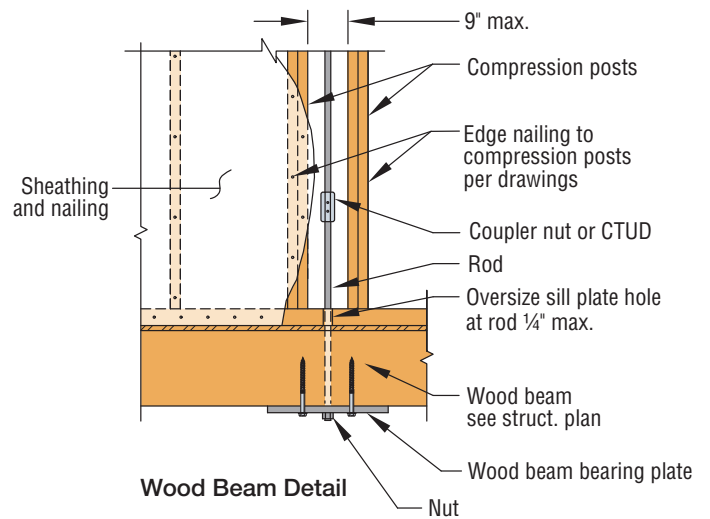

Wood Beam Detail

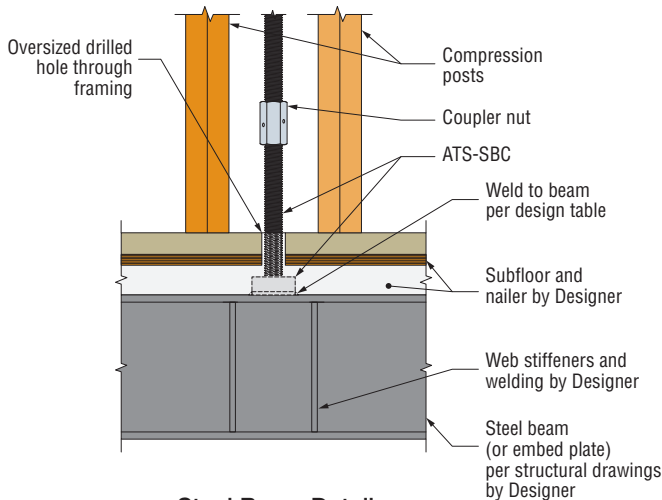

Steel Beam Detail

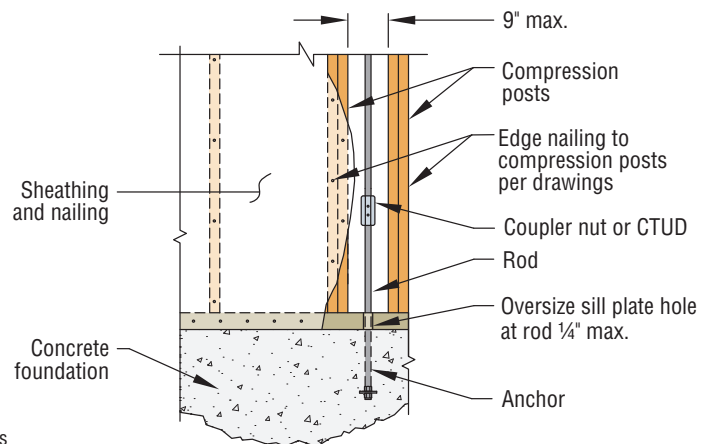

Concrete Detail

Sole-Plate-to-Rim-Board Shear Connections with Screws

The Simpson Strong-Tie® Strong-Drive® SDWC Truss, SDWH Timber-Hex, SDWS Timber, and SDS Heavy-Duty Connector screws may be used to attach a sole plate to a rim board according to the following table. Testing was based on ICC-ES Acceptance Criteria AC233 and analyzed per CSA Standard O86-14.

Limit States Design Shear Values for Sole-Plate-to-Rim-Board Screw Connections

Model	Screw Size (in.)	Model No.	Minimum Penetration into Rim Board (in.)	Factored Lateral Resistances (lb.) per Screw ($K_D = 1.15$)							
				2x D.Fir-L Rim Board		2x S-P-F Rim Board		1¼" LVL Rim Board		1¼" LSL Rim Board	
				Sole Plate		Sole Plate		Sole Plate		Sole Plate	
				D.Fir-L	S-P-F	D.Fir-L	S-P-F	D.Fir-L	S-P-F	D.Fir-L	S-P-F
Strong-Drive SDWC Truss Screw	0.152 x 4.5	SDWC15450	2.25	310	280	300	270	—	—	—	—
	0.152 x 6	SDWC15600	2.25	310	280	300	270	—	—	—	—
Strong-Drive SDWH Timber Hex Screw	0.195 x 4	SDWH19400DB	1.75	435	400	425	385	445	400	445	400
	0.195 x 6	SDWH19600DB ⁷	2	450	410	430	395	450	415	450	415
Strong-Drive SDWS Timber Screw	0.220 x 4	SDWS22400DB	1.75	510	470	495	455	520	470	520	470
	0.220 x 5	SDWS22500DB	2	510	470	495	455	520	470	520	470
	0.220 x 6	SDWS22600DB	2	530	485	505	465	530	490	530	490
Strong-Drive SDS Heavy-Duty Connector Screw	0.242 x 4.5	SDS25412	2	545	505	520	485	510	505	550	505
	0.242 x 5	SDS25500	2	545	505	530	485	510	505	550	505
	0.242 x 6	SDS25600	2	545	505	530	485	510	505	550	505

1. Factored resistances shown have been developed in accordance with 12.11 CSA O86-14 based on testing per ICC-ES AC233 and are limited to parallel-to-grain loading.
2. Apply the adjustment factors K_D , K_{SF} and K_T as per 12.11.4.1 CSA O86-14 when applicable.
3. Minimum spacing and end distances shall be per 12.11.2.2 CSA O86-14 O86-09 using the following nominal diameter sizes: SDWC—0.235"; SDS—0.250"; SDWH—0.268"; SDWS—0.300".
4. Minimum spacing of the SDS for LVL and LSL applications is 6" o.c., minimum end distance is 6", and minimum edge distance is ¾".
5. Wood structural panel up to 1 ½" thick is permitted between the sole plate and rim board provided it is fastened to the rim board per code and the minimum penetration of the screw into the rim board is met.
6. A double 2x sole plate is permitted provided it is independently fastened per the code and the minimum screw penetration per the table is met.
7. The SDWS19600 may be substituted for the SDWH19600DB when interior dry conditions exist.
8. The SDWC has not been evaluated with LVL or LSL rim boards.

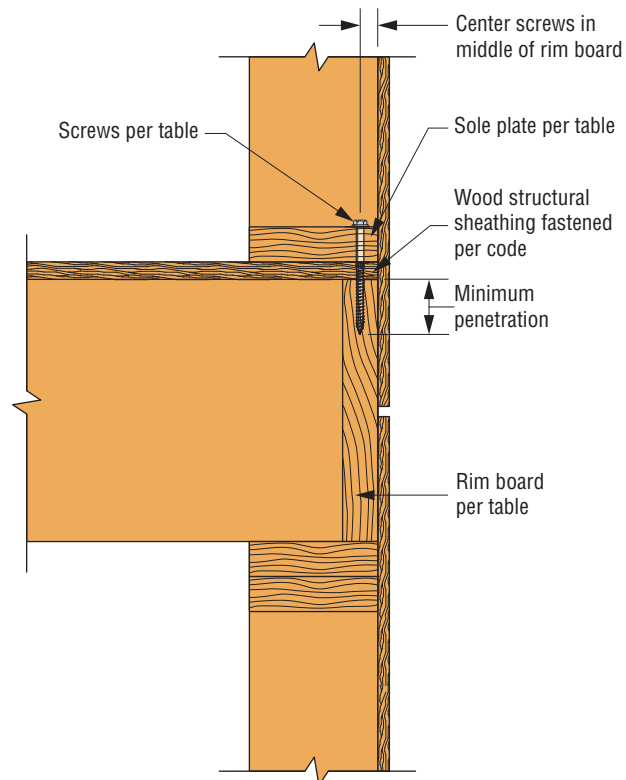

Cross-Laminated Timber Connectors

Simpson Strong-Tie offers a line of connectors for cross-laminated timber (CLT) construction. The AE and ABR heavy angles are used to transfer shear forces between CLT wall and floor panels. Both series of angles have been tested using S-P-F cross-laminated timber manufactured to ANSI/APA PRG 320 standard and can be installed using proprietary CNA ring-shank nails or Strong-Drive® SD Structural Connector screws.

Because nailing and laminating 2x6 studs into a solid wall is challenging and cumbersome, the use of cross-laminated timber (CLT) to create a solid wood elevator shaft is gaining popularity. By using CLT for the shaft walls, the connections between perpendicular walls can be better defined and their quality and consistency are less dependent on workmanship. Simpson Strong-Tie® ABR/AE connectors are ideal in a wood elevator shaft application.

Finish: Galvanized

Installation:

- Use all specified fasteners.
- Installation and fasteners schedule assumes platform framing. Install vertical leg at bottom edge of CLT wall panel and horizontal leg on CLT floor panel with 3 7/8" minimum edge distance.

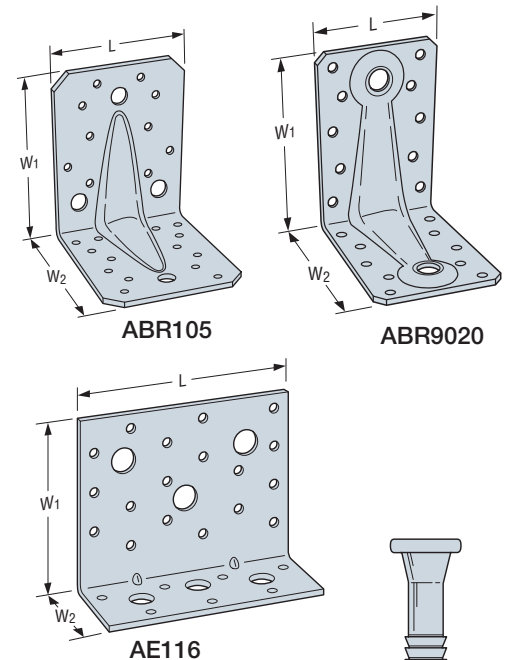

Model No.	Dimensions (mm)				Fasteners		Factored Resistance (K _D = 1.15)			
	t	W ₁	W ₂	L	Horizontal Leg	Vertical Leg	F ₁	F ₂	F ₃	F ₄
							lb.	lb.	lb.	lb.
ABR9020	2	88	88	65	(10) CNA4x60	(10) CNA4x60	1525	510	1925	510
					(10) SD#10x2½	(10) SD#10x2½	6.78	2.27	8.56	2.27
ABR105	3	105	105	90	(14) CNA4x60	(10) CNA4x60	2320	1440	1925	1440
					(14) SD#10x2½	(10) SD#10x2½	10.31	6.41	8.56	6.41
AE116	3	90	48	116	(7) CNA4x60	(18) CNA4x60	1885	500	3330	700
					(7) SD#10x2½	(18) SD#10x2½	8.38	2.23	14.81	3.12
AE116	3	90	48	116	(7) CNA4x60	(18) CNA4x60	2735	1440	3330	2015
					(7) SD#10x2½	(18) SD#10x2½	12.16	6.41	14.81	8.97
AE116	3	90	48	116	(7) CNA4x60	(18) CNA4x60	2125	900	2125	350
					(7) SD#10x2½	(18) SD#10x2½	9.45	4.01	9.45	1.56
AE116	3	90	48	116	(7) CNA4x60	(18) CNA4x60	2980	2140	2980	1010
					(7) SD#10x2½	(18) SD#10x2½	13.25	9.53	13.25	4.49

CNA4 x 60

1. Factored resistances have been increased 15% for earthquake or wind loading with no further increase allowed. Reduce where other load durations govern.
2. Factored resistances are based on cross-laminated timber manufactured to ANSI/APA PRG 320 using S-P-F material.
3. **Nails:** CNA4x60 = 4.1 mm diameter x 60 mm long proprietary ring-shank nail.
4. **Screws:** SD#10x2½ (model SD9212) = 0.131" dia. x 2½" long.

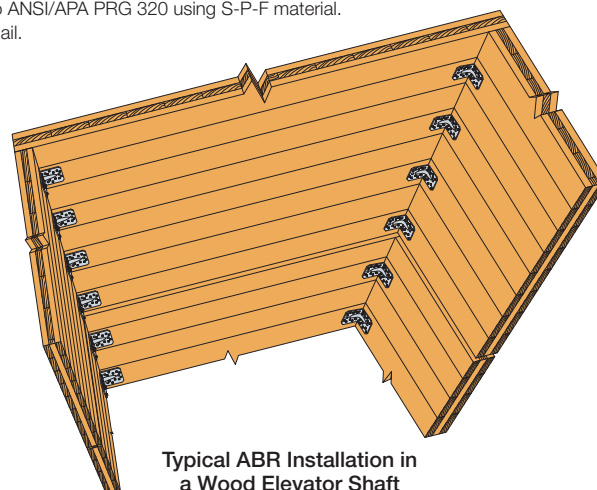
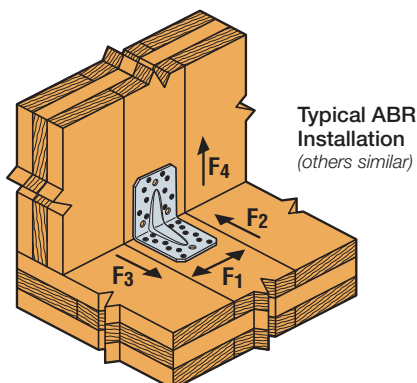

On site for your success

Ensuring the integrity of mid-rise structures against seismic and wind forces requires many complex design considerations unique to each project. Our onsite knowledge is the perfect complement to our Strong-Rod systems. With Simpson Strong-Tie field support, you'll have highly skilled experts on the jobsite to help you manage project changes,

answer product questions and supply engineering advice. We offer training, conduct pre-construction meetings and provide a project overview so that your team can build the safest structure possible while keeping material costs low and installation easy. When it comes to onsite support, we're there every step of the way.

