



STRONG-WALL[®] WOOD SHEARWALLS

C-L-WSWCAN21



(800) 999-5099
strongtie.com

Design Flexibility



Delivering Customization to Factory-Built Shearwalls

Prefabricated shearwalls from Simpson Strong-Tie are synonymous with high quality and performance. Over the years, we have worked diligently to ensure that our Strong-Wall® line of code-listed shearwalls provide enhanced structural support, allow design flexibility and help lower labour costs through easier installation.

Simpson Strong-Tie introduces the latest enhancements to our customizable and field-trimmable Strong-Wall® Wood Shearwall (WSW) product line. The holdowns installed on the WSW now provide front, back and side access, facilitating installation of the anchorage attachment in various framing conditions. The front access opening also allows for easy inspection of the connection to the anchor bolt. The connection from the top of the panel to the framing has also been updated. There are now two options, designed to accommodate different installer preferences.

Simpson Strong-Tie maintains a large group of dedicated engineers and field representatives to support your efforts — because your best chance of creating a long-lasting structure is before you start building it.



Introduction

For more than 60 years, Simpson Strong-Tie has focused on creating structural products that help people build safer and stronger homes and buildings. A leader in structural systems research and technology, Simpson Strong-Tie is one of the largest suppliers of structural building products in the world. The Simpson Strong-Tie commitment to product development, engineering, testing and training is evident in the consistent quality and delivery of its products and services.

For more information, visit the company's website at strongtie.com.

The Simpson Strong-Tie Company Inc. No-Equal Pledge® includes:

- Quality products value-engineered for the lowest installed cost at the highest-rated performance levels
- The most thoroughly tested and evaluated products in the industry
- Strategically located manufacturing and warehouse facilities
- National code agency listings
- The largest number of patented connectors in the industry
- Global locations with an international sales team
- In-house R&D and tool and die professionals
- In-house product testing and quality control engineers
- Support of industry groups including AISI, AITC, ASTM, ASCE, AWC, AWWA, ACI, AISC, CSI, CFSEI, ICFA, NBMDA, NLBMDA, SBCA, SDI, SETMA, SFA, SFIA, STAFDA, SREA, NFBA, TPI, WDSC, WIJMA, WTCA and local engineering groups.



The Simpson Strong-Tie Quality Policy

We help people build safer structures economically. We do this by designing, engineering and manufacturing No-Equal® structural connectors and other related products that meet or exceed our customers' needs and expectations. Everyone is responsible for product quality and is committed to ensuring the effectiveness of the Quality Management System.

Karen Colonias
Chief Executive Officer

Getting Fast Technical Support

When you call for engineering technical support, we can help you quickly if you have the following information at hand. This will help us to serve you promptly and efficiently.

- Which Simpson Strong-Tie® catalogue are you using? (See the front cover for the catalogue number.)
- Which Simpson Strong-Tie product are you using?
- What is your design code and building jurisdiction?
- Is your structure residential or commercial?
- What is your application?
- What is your load requirement?



We Are ISO 9001:2015 Registered

Simpson Strong-Tie is an ISO 9001:2015 registered company. ISO 9001:2015 is an internationally-recognized quality assurance system which lets our domestic and international customers know that they can count on the consistent quality of Simpson Strong-Tie® products and services.

General Notes and Table of Contents

General Notes

These General Notes are provided to ensure proper design, use and installation of the Simpson Strong-Tie® Strong-Wall® Wood Shearwall and must be followed fully.

- a. Install products according to this catalogue. Changes in installation methods or modifications to the product and associated systems (other than those indicated in this document) should only be made by a design professional of record. Altered installation procedures and the performance of modified products are the sole responsibility of the design professional of record.
- b. The building shall be designed in accordance with the appropriate building code and meet local, state, and federal requirements. Verify design requirements with the local building official. Concrete foundation design remains the responsibility of the design professional of record.
- c. Strong-Wall Wood Shearwalls are part of the overall lateral-force-resisting system of the structure. The design of this system, including a complete load path to transfer lateral forces from the structure to the ground, is the responsibility of the design professional of record.
- d. In addition to the information and instructions found in this catalogue, all warnings, general notes and instructions, warranty information and terms and conditions of sale contained within the *Strong-Wall® Shearwalls* catalogue apply.

Table of Contents

General Notes	5
Strong-Wall® Wood Shearwall Features and Benefits	6
Strong-Wall® Wood Shearwall Applications	7
Product and Kit Descriptions	8–9
Standard and Tall-Wall Framing on Concrete Foundations	10–13
Garage Portal Systems on Concrete Foundations	14–16
Two-Storey Stacked on Concrete Foundations	17–20
Anchorage Solutions	21–25
Installation Details	26–41



Strong-Wall® Wood Shearwall Features and Benefits



Code-Evaluated

Delivering Easy-to-Install, Code-Evaluated Solutions

The Simpson Strong-Tie® Strong-Wall® Wood Shearwall is a specially designed, prefabricated, engineered-wood panel that helps structures resist lateral forces such as those created by earthquakes and high winds. The Strong-Wall Wood Shearwall has been evaluated to the 2015 National Building Code of Canada (NBC) and can help you resist these forces efficiently and confidently with the following features:

- **Field Adjustable** – Can be field-trimmed and drilled
- **Stronger Wall** – Narrow panel widths have significantly higher factored resistances than the original Wood Strong-Wall
- **More Applications** – Suitable for residential, multi-family, and light-frame commercial construction and in tall-wall framing applications up to 20'.
- **Front Access** – Newly designed front access allows for easier anchor bolt installation and inspection
- **Easy to Install** – Reusable templates locate the required holdown anchor bolts accurately in the foundation
- **Support and Service** – Simpson Strong-Tie provides unmatched engineering technical support and experienced field representation



Engineering Technical Support



Field Adjustable

Strong-Wall® Wood Shearwall Applications

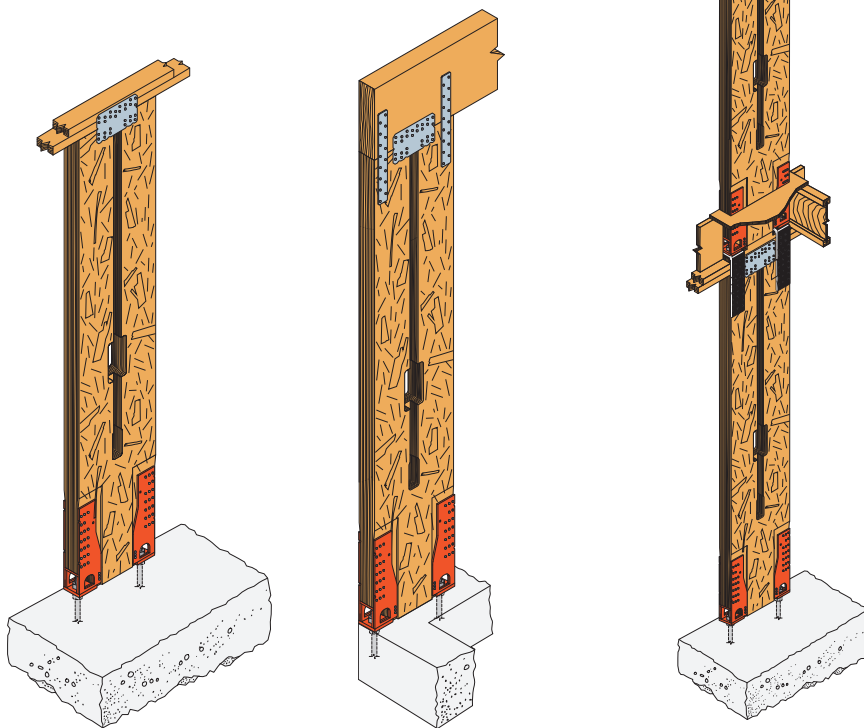
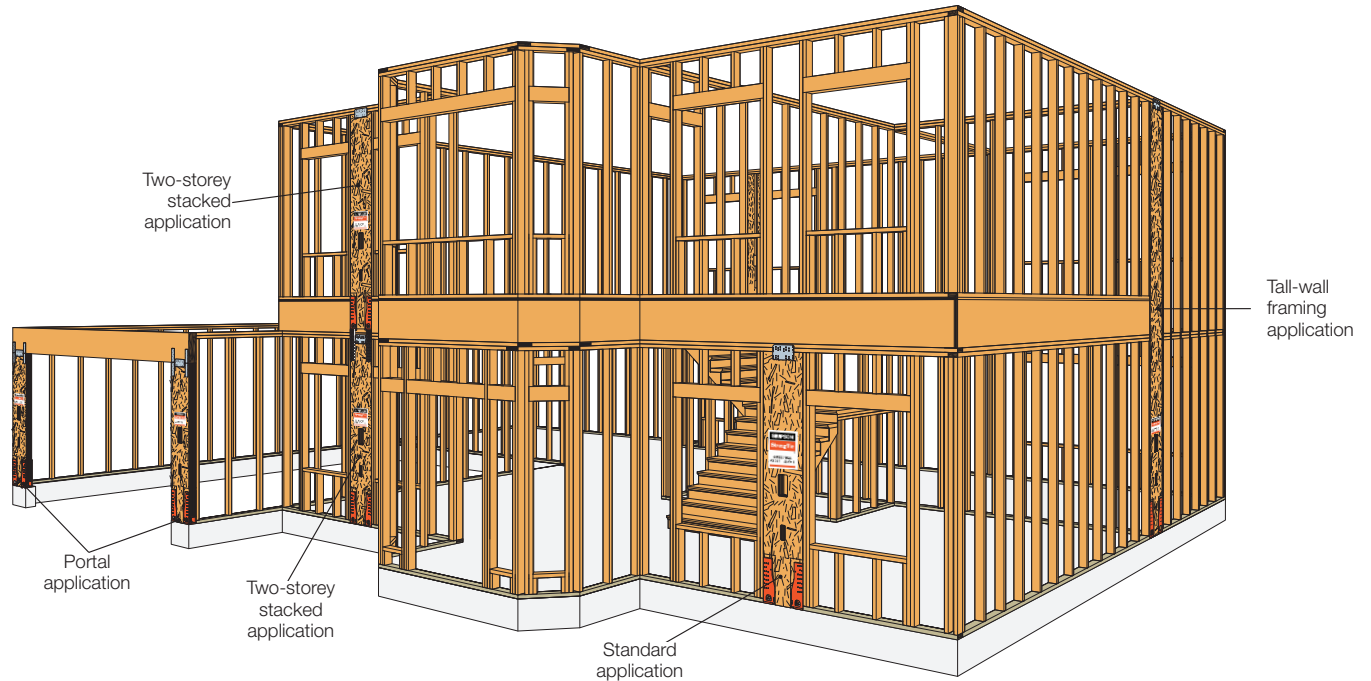

Standard and Tall-Wall Framing Applications

- Narrow wall spaces
- Wall heights up to 20'

Portal Applications

- Narrow wall spaces
- Garages
- Large windows and doors
- Increased capacities when used in a portal

Two-Storey Stacked Application

- Narrow wall spaces
- Multi-storey installation kit (MSK) required (order separately)
- Total assembled heights up to 24'

Product Storage

Protect product from sun and water



CAUTION:

Wrap is slippery when wet or icy

Use support blocks at 10' on-center to keep bundles out of mud and water

Product and Kit Descriptions

Standard Product Description

All Strong-Wall® Wood Shearwalls are supplied with top-of-wall shear transfer plates, nuts, washers and installation instructions. Additionally, shearwalls 100" or less in height are supplied with four portal straps.



Product and Kit Descriptions

Alternative Top Connection Fastener Kit

Required for alternative top connections using a single WSW-TOW plate (supplied with wall) installed from only one side with Strong-Drive® Connector screws.

Strong-Wall® Wood Shearwall Alternative Connection Kit

Model No.	Contents
WSW-TOW12KT	(20) #10 x 1½" SD Connector Screws (2) ¼" x 6" SDS Heavy-Duty Connector Screws
WSW-TOW18KT	(28) #10 x 1½" SD Connector Screws (4) ¼" x 6" SDS Heavy-Duty Connector Screws
WSW-TOW24KT	(40) #10 x 1½" SD Connector Screws (8) ¼" x 6" SDS Heavy-Duty Connector Screws

1. Use kit fasteners to attach (1) of the (2) WSW-TOW plates included with the Strong-Wall Wood shearwall. Plate may be installed on either panel face.

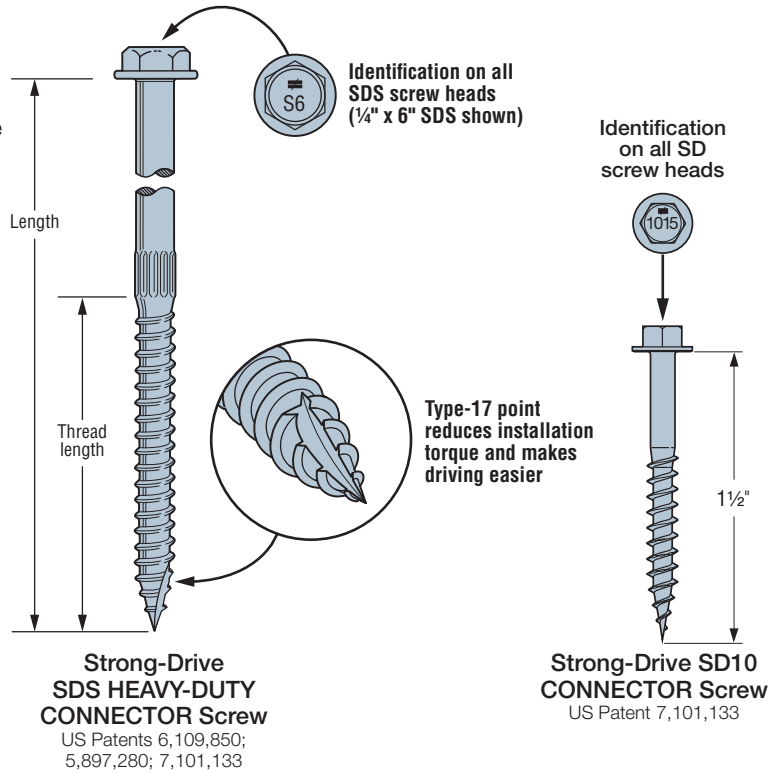

Portal Kits

(Included with all panels 100" or less in height)

Required for portal-frame applications. Kit includes four portal straps and comes standard with all panels that are 100" or less in height. Order the kit separately if using panels that are more than 100" tall in a portal application.

Model No.: WSW-PK

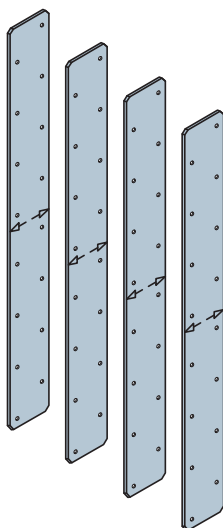

Multi-Storey Kits (MSK)

Required for two-storey stacked applications. Kit includes two holdowns with pre-attached bolts and a bearing block. See p. 18 for two-storey stacked details.

Model No.: WSW-MSK12KT, WSW-MSK18KT, WSW-MSK24KT

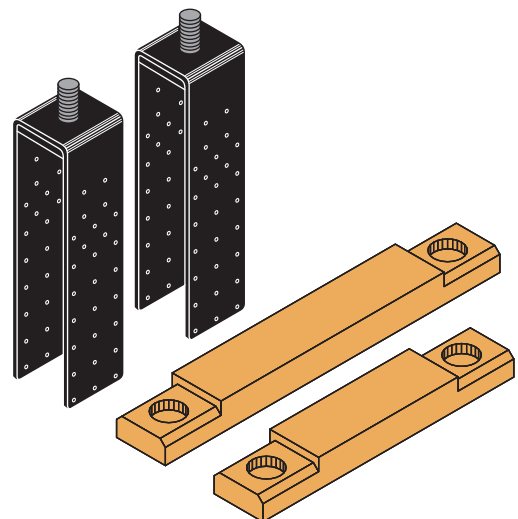

Standard and Tall-Wall Framing on Concrete Foundations

Strong-Wall® Wood Shearwall Product Data

Model No.	W (in.)	H (in.)	Anchor Bolts		Total Wall Weight (lb.)
			Quantity	Dia. (in.)	
WSW12x7-78	12	78	2	7/8	100
WSW18x7-78	18	78	2	7/8	145
WSW12x7.5-85	12	85½	2	7/8	110
WSW18x7.5-85	18	85½	2	7/8	155
WSW12x8-93	12	93¼	2	7/8	115
WSW12x8-96	12	96	2	7/8	115
WSW18x8-93	18	93¼	2	7/8	165
WSW18x8-96	18	96	2	7/8	165
WSW24x8-93	24	93¼	2	1	225
WSW24x8-96	24	96	2	1	225
WSW12x9-105	12	105¼	2	7/8	130
WSW12x9-108	12	108	2	7/8	130
WSW18x9-105	18	105¼	2	7/8	185
WSW18x9-108	18	108	2	7/8	185
WSW24x9-105	24	105¼	2	1	245
WSW24x9-108	24	108	2	1	245
WSW12x10-117	12	117¼	2	7/8	140
WSW12x10-120	13	120	2	7/8	140
WSW18x10-117	18	117¼	2	7/8	205
WSW18x10-120	18	120	2	7/8	205
WSW24x10-117	24	117¼	2	1	270
WSW24x10-120	24	120	2	1	270
WSW12x11-129	12	129¼	2	7/8	150
WSW18x11-129	18	129¼	2	7/8	220
WSW24x11-129	24	129¼	2	1	295
WSW12x12-141	12	141¼	2	7/8	165
WSW18x12-141	18	141¼	2	7/8	240
WSW18x12-144	18	144	2	7/8	240
WSW24x12-141	24	141¼	2	1	320
WSW24x12-144	24	144	2	1	320
WSW18x13-153	18	153¼	2	7/8	255
WSW24x13-153	24	153¼	2	1	345
WSW24x14-168	24	168	2	1	375
WSW24x16-192	24	192	2	1	425
WSW18x20-240	18	240	2	7/8	385
WSW24x20-240	24	240	2	1	520

1. For heights not listed, order the next tallest panel and trim to fit. Minimum trimmed height for all panels is 74½".
2. All panels come with two pre-attached holdowns, two grade 5 hex nuts, two flat structural washers, two WSW-TOW top-connection plates (width based on panel model), and installation instructions.
3. All panels are 3½" thick.

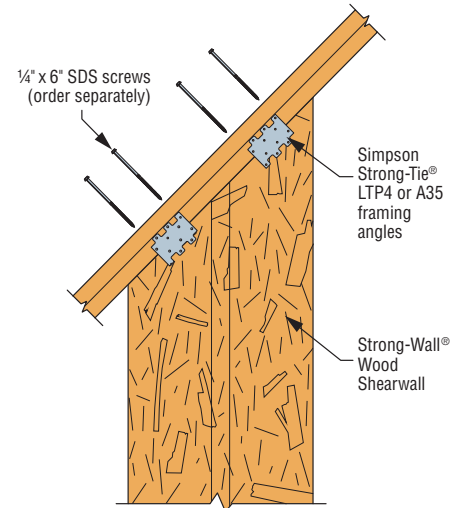

Rake Wall Application

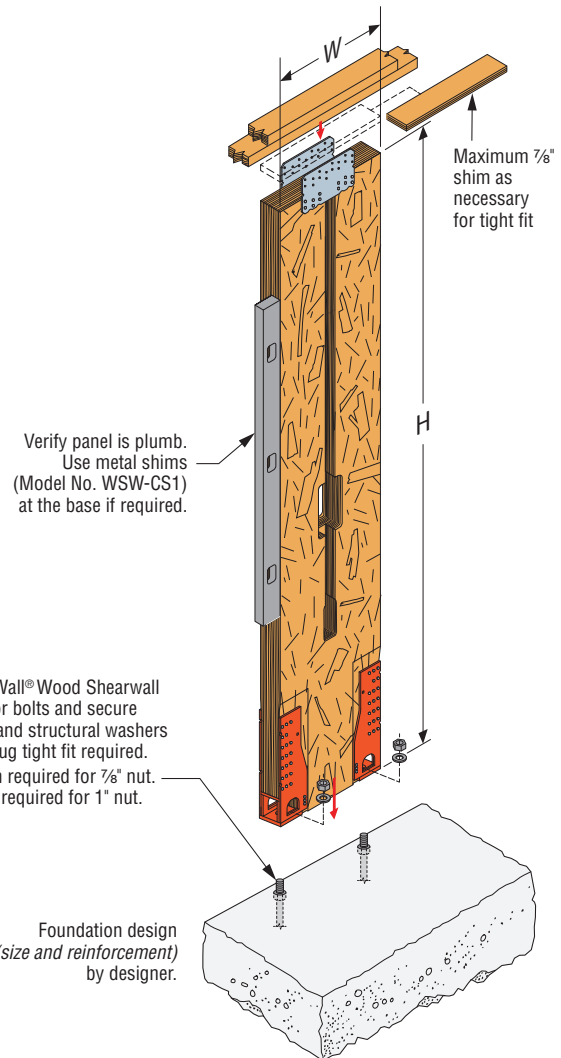

Standard Installation

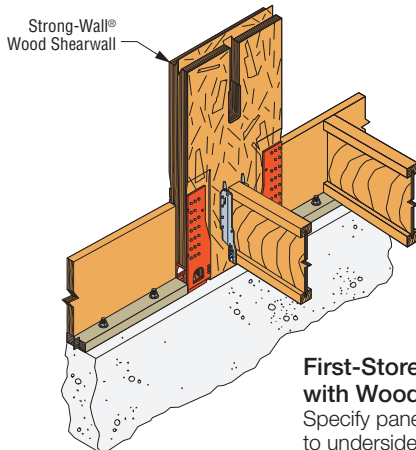

First-Storey Installation with Wood Floor System

Specify panel height from top of foundation to underside of the top plates or beam.

Standard and Tall-Wall Framing on Concrete Foundations

Simpson Strong-Tie® Strong-Wall® Wood Shearwalls combine design flexibility with performance. Field trimmable, they can be customized to accommodate varying heights or rake walls.

Installation

- All panels may be field trimmed to a minimum of 74½". Trim height from top of panel only, do not trim from sides or bottom. Drilling holes in the Strong-Wall® Wood Shearwalls is not allowed except as shown on p. 36.
- Anchor-bolt nuts should be snug tight.
- Maximum shim thickness between the shearwall and top plates or header is 7/8".
- Walls may also be used in 2x6 wall framing. Install the panel flush to the outside face of the framing and add furring to the opposite side.
- Standard top-of-wall connections install with nails.
- Alternative top connection may be used in lieu of standard top connection based on installer preference.

Strong-Wall® Wood Shearwall Naming Legend

WSW18x8-96

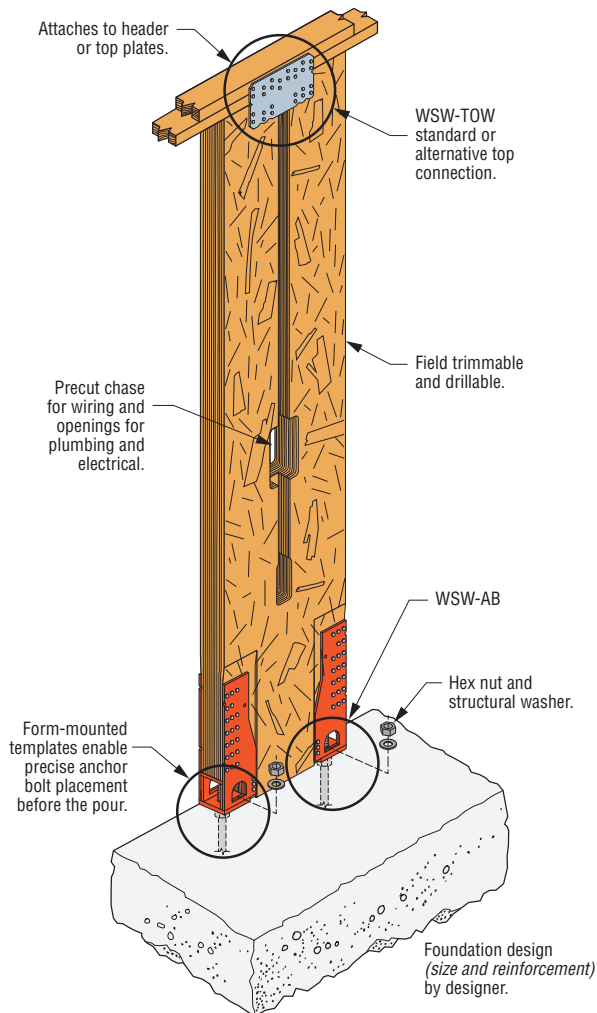
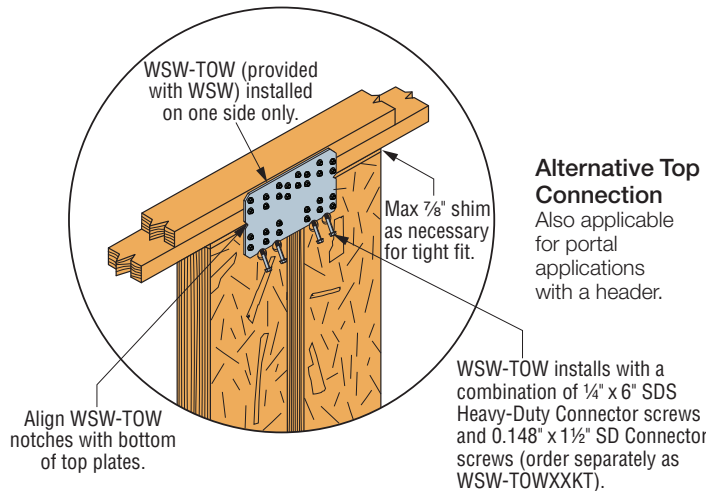
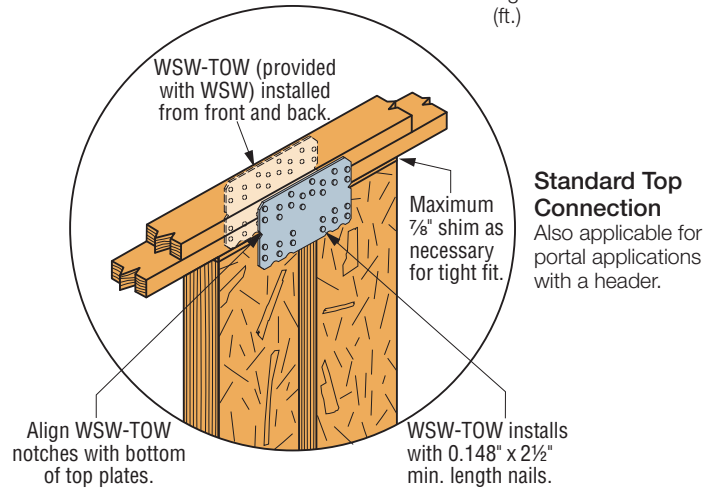
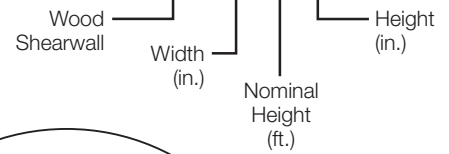

Standard Installation

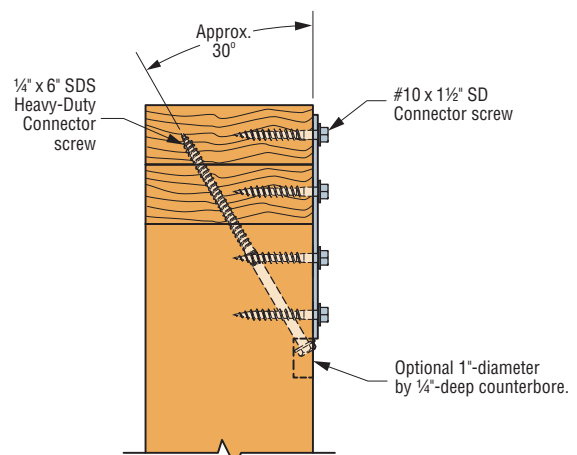

Alternative Top Connection
Side View

Standard and Tall-Wall Framing on Concrete Foundations

Strong-Wall® Wood Shearwall Standard Application on Concrete Foundation

Strong-Wall Wood Shearwall Model No.	Width, W		Height, H		Factored Vertical Resistance, P _r	Factored Shear Resistance, V _r	Drift at V _r	Service Load at H/500
	in.	mm	in.	mm				
	lb.	kN	lb.	kN	in.	mm	lb.	kN
WSW12x7	12		78		4500	1255	0.38	585
	305		1981		20.02	5.58	10	2.60
WSW18x7	18		78		8000	2925	0.38	1480
	457		1981		35.58	13.02	10	6.58
WSW24x7	24		78		8000	6820	0.38	3340
	610		1981		35.58	30.33	10	14.86
WSW12x8	12		93.25		4500	1125	0.47	525
	305		2369		20.02	5.01	12	2.32
WSW18x8	18		93.25		8000	2830	0.47	1345
	457		2369		35.58	12.60	12	5.98
WSW24x8	24		93.25		8000	5910	0.47	2835
	610		2369		35.58	26.28	12	12.61
WSW12x9	12		105.25		4500	920	0.53	415
	305		2673		20.02	4.09	13	1.84
WSW18x9	18		105.25		8000	2300	0.53	1095
	457		2673		35.58	10.22	13	4.87
WSW24x9	24		105.25		8000	5115	0.53	2375
	610		2673		35.58	22.75	13	10.57
WSW12x10	12		117.25		4500	730	0.59	315
	305		2978		20.02	3.24	15	1.40
WSW18x10	18		117.25		8000	2010	0.59	915
	457		2978		35.58	8.94	15	4.07
WSW24x10	24		117.25		8000	4335	0.59	2040
	610		2978		35.58	19.27	15	9.07
WSW12x11	12		129.25		4500	660	0.65	280
	305		3283		20.02	2.93	16	1.26
WSW18x11	18		129.25		8000	1805	0.65	840
	457		3283		35.58	8.04	16	3.74
WSW24x11	24		129.25		8000	4025	0.65	1825
	610		3283		35.58	17.89	16	8.11
WSW12x12	12		141.25		4500	555	0.71	235
	305		3588		20.02	2.46	18	1.04
WSW18x12	18		141.25		8000	1605	0.71	735
	457		3588		35.58	7.13	18	3.28
WSW24x12	24		141.25		8000	3570	0.71	1600
	610		3588		35.58	15.87	18	7.11
WSW18x13	18		153.25		4500	1420	0.76	645
	457		3893		20.02	6.32	19	2.87
WSW24x13	24		153.25		4500	3165	0.76	1400
	610		3893		20.02	14.08	19	6.23
WSW18x14	18		165.25		4500	1125	0.82	500
	457		4197		20.02	4.99	21	2.22
WSW24x14	24		165.25		4500	2540	0.82	1150
	610		4197		20.02	11.29	21	5.11
WSW18x16	18		189.25		4500	990	0.94	435
	457		4807		20.02	4.41	24	1.93
WSW24x16	24		189.25		4500	2210	0.94	945
	610		4807		20.02	9.82	24	4.19
WSW18x18	18		213.25		3000	780	1.06	335
	457		5417		13.34	3.47	27	1.48
WSW24x18	24		213.25		3000	1735	1.06	725
	610		5417		13.34	7.72	27	3.22
WSW18x20	18		237.25		3000	620	1.18	260
	457		6026		13.34	2.77	30	1.15
WSW24x20	24		237.25		3000	1345	1.18	580
	610		6026		13.34	5.99	30	2.58

- Resistances include evaluation of bearing stresses on concrete foundation with compressive strength, $f'_c = 2900$ psi (20 MPa).
- Seismic design based on NBC 2015 using $R_d = 3.0$ and $P_o = 1.7$.
- High strength (HS) anchor bolts are required. See pp. 21–25 for anchor bolt information and anchorage solutions.
- Factored vertical resistance denotes the total maximum concentric vertical load permitted on the panel acting in combination with the factored shear resistance.
- Factored resistances and drift values may be interpolated for intermediate heights. For panels trimmed to less than 78" tall, use the values for the 78" tall panel.
- A minimum of one 2x6 full-height stud at each side of WSW panels taller than 14'-6" is required and must be designed and detailed, including the attachment to the WSW, by the designer.
- See p. 13 for out-of-plane and axial capacities.
- WSW24x7 must be trimmed from a WSW24x8 shearwall; WSW18x 14, 16 and 18 shearwalls are trimmed from a 20' tall panel.
- Service load at H/500 to be used for wind calculations in accordance with 4.1.3.5.(3) of NBC 2015.
- Anchor tension loads at design shear values and including the effect of vertical load may be determined using the following equation:

$$T = [(V \times H) / B] - P/2$$
, where:
 T = Anchor tension load (lb.)
 V = Design shear load (lb.)
 P = Applied vertical load (lb.)
 H = Panel height (in.)
 B = Moment arm (in.); 8.06" for WSW12, 13.94" for WSW18, 18.94" for WSW24

Standard and Tall-Wall Framing on Concrete Foundations

Strong-Wall Wood Shearwall Out-of-Plane Lateral Resistances for Single-Storey Walls on Concrete Foundation (ULS)

Panel Attachment	Strong-Wall Wood Shearwall Model No.	Nominal Height of Shearwall (ft.)											
		7	7.5	8	9	10	11	12	13	14	16	18	20
		PSF											
kPa													
Top Plates	WSW12	430	390	360	320	285	260	235	N/A	N/A	N/A	N/A	N/A
		20.58	18.77	17.21	15.25	13.69	12.42	11.36					
	WSW18	385	350	320	285	255	230	210	195	180	155	140	125
		18.40	16.79	15.39	13.64	12.24	11.11	10.16	9.37	8.54	7.48	6.65	5.98
	WSW24	415	380	350	310	275	250	230	210	195	170	150	135
		19.92	18.17	16.66	14.76	13.25	12.02	11.00	10.14	9.25	8.09	7.19	6.47
Header	WSW12	325	300	275	240	220	195	180	N/A	N/A	N/A	N/A	N/A
		15.66	14.29	13.10	11.61	10.42	9.45	8.65					
	WSW18	220	200	185	165	145	135	120	N/A	N/A	N/A	N/A	N/A
		10.57	9.64	8.84	7.83	7.03	6.38	5.84					
	WSW24	165	150	140	125	110	100	90	N/A	N/A	N/A	N/A	N/A
		7.93	7.24	6.64	5.88	5.28	4.79	4.38					

See footnotes below.

Strong-Wall Wood Shearwall Out-of-Plane Lateral Resistances for Single-Storey Walls on Concrete Foundation (SLS)

Panel Attachment	Strong-Wall Wood Shearwall Model No.	Nominal Height of Shearwall (ft.)											
		7	7.5	8	9	10	11	12	13	14	16	18	20
		PSF											
kPa													
Top Plates	WSW12	350	265	205	145	105	80	60	N/A	N/A	N/A	N/A	N/A
		16.65	12.71	9.83	6.87	4.99	3.73	2.86					
	WSW18	350	265	205	145	105	80	60	45	35	25	15	10
		16.65	12.71	9.83	6.87	4.99	3.73	2.86	2.25	1.71	1.15	0.81	0.59
	WSW24	350	265	205	145	105	80	60	45	35	25	15	10
		16.65	12.71	9.83	6.87	4.99	3.73	2.86	2.25	1.71	1.15	0.81	0.59
Header	WSW12	215	170	135	100	75	55	45	N/A	N/A	N/A	N/A	N/A
		10.23	8.11	6.50	4.74	3.56	2.75	2.16					
	WSW18	215	170	135	100	75	55	45	N/A	N/A	N/A	N/A	N/A
		10.23	8.11	6.50	4.74	3.56	2.75	2.16					
	WSW24	165	150	135	100	75	55	45	N/A	N/A	N/A	N/A	N/A
		7.93	7.24	6.50	4.74	3.56	2.75	2.16					

1. ULS = Ultimate Limit States; SLS = Serviceability Limit States.

2. Resistances shown for header panel attachment require use of portal kit to resist header rotation.

3. Resistances for portal applications assume a maximum header depth of 14". For ULS, multiply the tabulated values by 0.88 and 0.78 for 16" and 18" deep headers respectively. For SLS multiply the tabulated values by 0.95 and 0.90 for 16" and 18" deep headers respectively.

4. Based on $K_D = 1.15$ and a deflection criteria of $L/360$. For $L/180$, multiply SLS values by two but shall not exceed the ULS values.

5. Out-of-plane lateral resistances act in combination with maximum factored vertical resistance.

6. Full-height studs at each side of WSW panels taller than 14'-6" are required and must be designed and detailed to resist factored out of plane loads in accordance with the NBC 2015.

7. N/A = Not applicable.

Strong-Wall Wood Shearwall Axial Resistances for Single-Storey Walls on Concrete Foundation (ULS)

Strong-Wall Wood Shearwall Model No.	Nominal Height of Shearwall (ft.)												
	7	7.5	8	9	10	11	12	13	14	16	18	20	
	lb.												
kN													
WSW12	41100	36200	31500	25200	20200	16200	13100	N/A	N/A	N/A	N/A	N/A	
	182.97	160.83	139.93	112.09	89.67	72.01	58.20						
WSW18	46000	46000	46000	43800	35100	28200	22800	18600	14600	10200	7300	5400	
	204.45	204.45	204.45	195.05	156.05	125.30	101.28	82.52	64.94	45.22	32.54	24.10	
WSW24	67600	67600	63700	51000	40800	32800	26500	21600	17000	11800	8500	6300	
	300.66	300.66	283.16	226.82	181.47	145.71	117.78	95.97	75.51	52.59	37.84	28.03	

1. Factored vertical resistance is the lesser of the WSW panel buckling capacity and concrete bearing capacity beneath the holdowns assuming a minimum specified concrete compressive strength $f'_c = 2900$ psi (20 MPa).

2. Factored vertical resistances assume concentric point load or uniformly distributed load without lateral loads present. For combined lateral and vertical loads, see p. 12.

3. Tabulated loads apply to single-storey panels on concrete foundations.

4. A minimum of one 2x6 full-height stud at each side of WSW panels taller than 14'-6" is required and must be designed and detailed, including the attachment to the WSW, by the designer.

5. N/A = Not applicable.

Garage Portal Systems on Concrete Foundations

The Strong-Wall® Wood Shearwall garage portal system provides higher shear capacity with reduced concrete anchorage requirements. Portal walls may be used in single- or double-portal applications and shall be installed with a minimum 3 1/8" x 9 1/4" single- or multiple-ply header depending upon loading and span requirements.

For product data and naming scheme information, see pp. 10–11.

Garage Header Rough Opening Height

Model No.	H Curb (in.)	Rough Opening Height (in.)
WSW12x7 WSW18x7 WSW24x7	5 1/2 6	6'-11 1/2" ¹ 7'-0"
WSW12x7.5 WSW18x7.5 WSW24x7.5	0	7'-1 1/2"
WSW12x8 WSW18x8 WSW24x8	5 1/2 6	8'-2 3/4" ² 8'-3 1/4" ²

1. If required rough opening height exceeds table value, specify next taller panel and trim as necessary. The Strong-Wall Wood Shearwalls may be trimmed to a minimum height of 74 1/2".
2. Furring down garage header may be required for correct rough opening height.
3. WSW24x7 and WSW24x7.5 must be trimmed from a WSW24x8 shearwall.

Installation

- Portal-frame connection kit is required for portal-frame applications.
- All panels may be trimmed to a minimum of 74 1/2". Trim height from top of panel only, do not trim from sides or bottom. Drilling holes in the Strong-Wall Wood Shearwalls is not allowed except as shown on p. 36.
- Anchor-bolt nuts should be snug tight.
- Maximum shim thickness between Strong-Wall Wood Shearwalls and the top plates or header is 7/8".
- Standard top-of-wall connections install with nails.
- Walls may also be used in 2x6 wall framing. Install the panel flush to the outside face of the framing and add furring to the opposite side.
- Walls may be installed with solid or multi-ply headers, see p. 41 Detail 4, 5/WSW4 for fastening and furring requirements.

Portal Frame Connection Kit

Model No.	Contents
WSW-PK	4 (10 gauge) WSW-PS straps

1. Portal-frame connection kit comes with panels that are 100" or less in height. The kit must be ordered separately for panels over 100" tall.

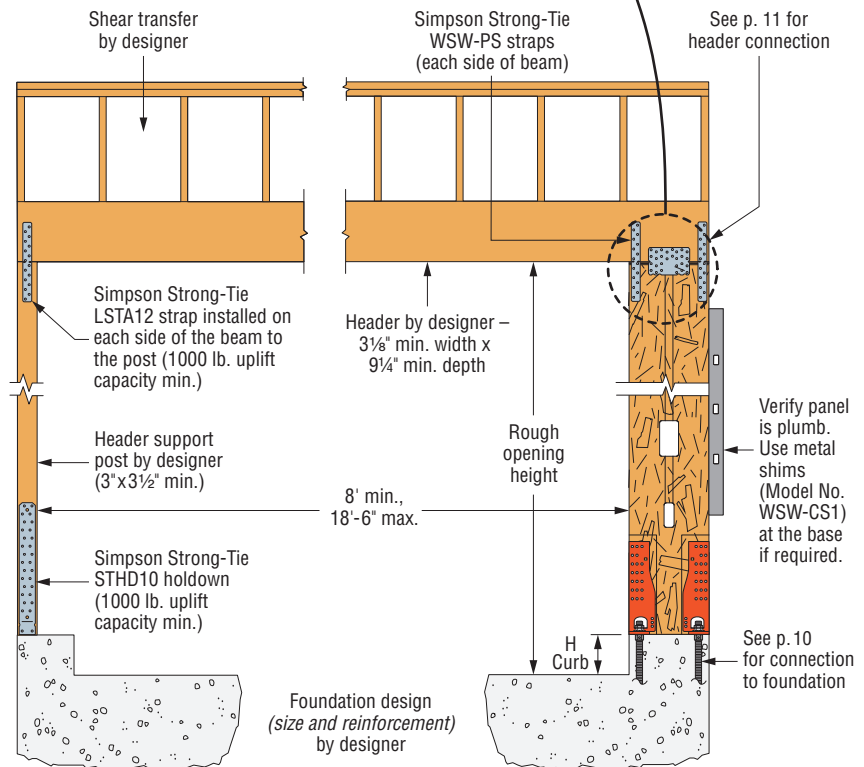
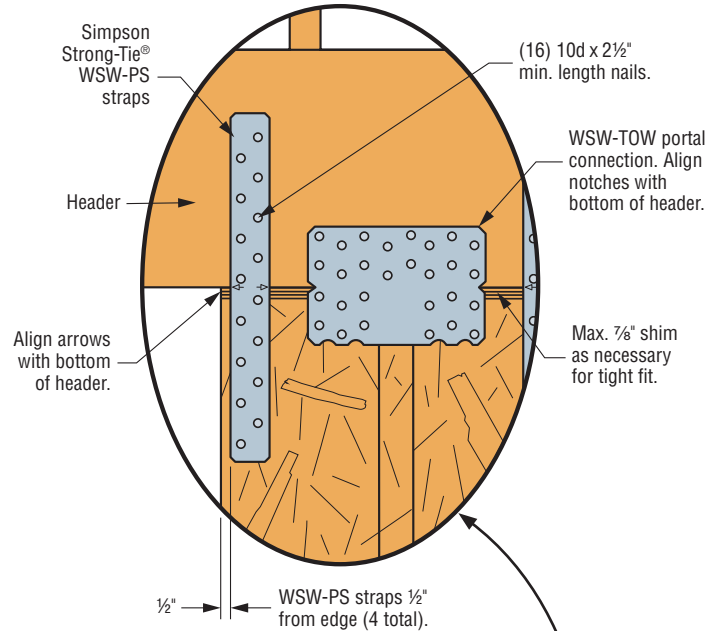

Single Portal Installation

Garage Portal Systems on Concrete Foundations

Portal Design Information

A portal frame under lateral loads causes the portal header to experience internal stresses in addition to those created by the primary loads (live, dead and snow). These additional stresses are called induced forces and must be considered when designing portal headers. To account for the induced forces from lateral loads, a concentrated end moment equal to the top-of-panel moment must be placed at the end of the beam that is connected to the WSW panel. For WSW12 and WSW18 panels, the moment induced into the portal header must be taken as 20% and 10%, respectively, of the total lateral moment. The total lateral moment is calculated as the design shear times the panel height. For headers with typical residential uniform loads, the induced moment and shear forces from a portal-frame system do not control the design. This is due to the 1.15 load duration factor K_D used in design and the induced stresses from wind and seismic loads.

The lateral and vertical loads shown on p. 16 for portal frames assume that the header size falls within the portal-frame parameters listed in the table.

Strong-Wall® Wood Shearwall Portal Header Design Parameters

Header Design Parameter	Allowable Range
Width	3 1/8" – 5 1/2"
Depth	9 1/4" – 18"
Clear Span	8' – 18' 6"
K	90 lb./in. – 4000 lb./in.

1. Single- or multiple-ply header members may be used.
2. Secondary moment, shear and axial forces shall be considered in header design.
3. Header design shall be by designer and assume gravity loads only induce simple span moments in beam.
4. Header stiffness (K) for use in WSW portal system may be determined using the following equation:

$$K = (E \times b \times d^3) / 12L^3$$
 where:
 E = Header modulus of elasticity (psi)
 b = Header width (in.)
 d = Header depth (in.)
 L = Header clear span (in.)

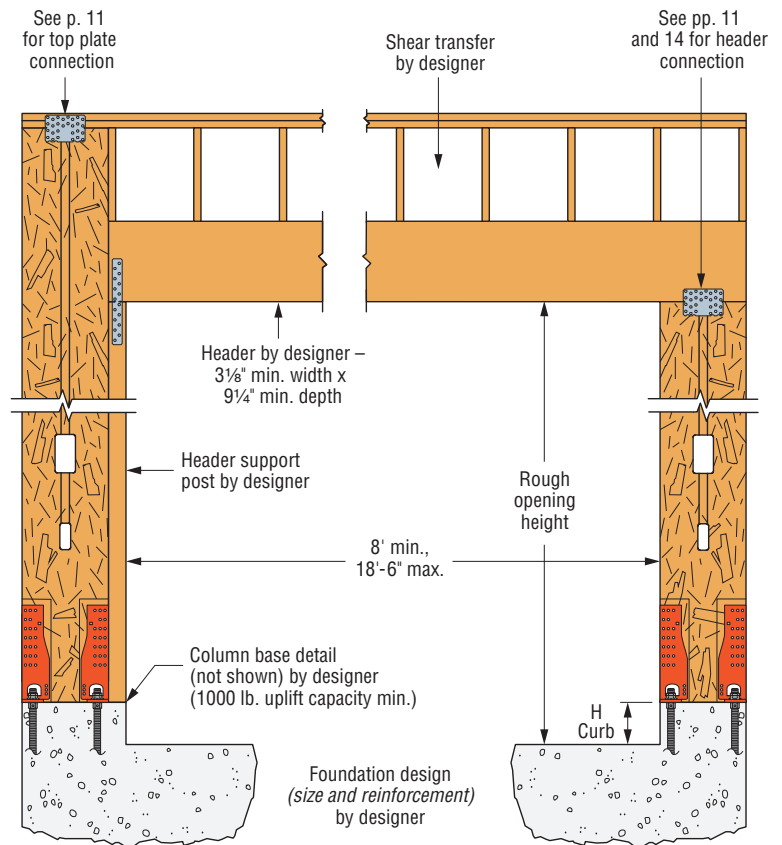

Alternate Garage Front Option 1

Alternate Garage Front Option 2

Alternative Garage Front Options

These alternative garage-front options may be used for applications when the Strong-Wall Wood Shearwall is installed at the full height (option 1) or without the additional Portal-Frame Kit (option 2), when higher capacity or reduced concrete anchorage is not needed. Refer to the Standard Application on Concrete Foundations on pp. 10–12 for product data and factored resistance values.

For Garage Wall Option 2, the designer shall design for:

1. Shear transfer
2. Out-of-plane loading effect
3. Increased overturning and drift due to additional height

Garage Portal Systems on Concrete Foundations

Strong-Wall® Wood Shearwall Single-Wall Garage Portal System on Concrete Foundation

Strong-Wall Wood Shearwall Model No.	Width, W	Height, H	Factored Vertical Resistance, P _r	Factored Shear Resistance, V _r	Drift at V _r	Service Load at H/500
	in.	in.	lb.	lb.	in.	lb.
	mm	mm	kN	kN	mm	kN
WSW12x7	12	78	8000	1940	0.47	960
	305	1981	35.58	8.63	12	4.27
WSW18x7	18	78	8000	3760	0.47	1865
	457	1981	35.58	16.73	12	8.29
WSW12x7.5	12	85.5	8000	1785	0.50	845
	305	2172	35.58	7.94	13	3.76
WSW18x7.5	18	85.5	8000	3430	0.50	1655
	457	2172	35.58	15.26	13	7.36
WSW12x8	12	93.25	8000	1535	0.53	700
	305	2369	35.58	6.82	13	3.10
WSW18x8	18	93.25	8000	3040	0.53	1430
	457	2369	35.58	13.53	13	6.35

- Resistances include evaluation of bearing stresses on concrete foundation with compressive strength, $f'_c = 2900$ psi (20 MPa).
- Seismic design based on NBC 2015 using $R_d = 3.0$ and $R_o = 1.7$.
- Values shown apply to Single-Wall Garage Portal Systems. The factored resistance for a Double-Wall Garage Portal System, which consists of two walls with a header continuous across both panels, may be taken as twice the table value.
- High strength (HS) anchor bolts are required. See pp. 21–25 for anchor bolt information and anchorage solutions.
- Factored vertical resistance denotes the total maximum concentric vertical load permitted on the panel acting in combination with the factored shear resistance.
- Factored resistances and drift values may be interpolated for intermediate heights. For panels trimmed to less than 78" tall, use the values for the 78" tall panel.
- See p. 13 for out-of-plane and axial capacities.
- Service load at H/500 to be used for wind calculations in accordance with 4.1.3.5.(3) of NBC 2015.
- Anchor tension loads at design shear values and including the effect of vertical load may be determined using the following equation:

$$T = [(k \times V \times H) / B] - P/2$$
, where:
 T = Anchor tension load (lb.); V = Design shear load (lb.); P = Applied vertical load (lb.); H = Panel height (in.)
 B = Moment arm (in.); 8.06" for WSW12, 13.94" for WSW18.
 k = Portal factor; 0.80 for WSW12 panels 93¼" or less in height, 0.90 for WSW18 panels 93¼" or less in height, 1.00 for all other panels.

Two-Storey Stacked on Concrete Foundations

The same Strong-Wall® Wood Shearwall models used for standard applications on concrete may be used in stacked wall applications. See Product data tables below for models that may be used in this application.

For product naming scheme information, see p. 11.

Two-Storey Stacked WSW Product Data – Upper Wall

Model No.	W (in.)	H (in.)	Total Wall Weight (lb.)
WSW18x9	18	105¼	185
WSW24x9	24	105¼	245
WSW18x10	18	117¼	205
WSW24x10	24	117¼	270
WSW18x11	18	129¼	220
WSW24x11	24	129¼	295
WSW18x12	18	141¼	240
WSW24x12	24	141¼	320

1. Order WSW-MSKXXXKT separately for two-storey stacked applications.
2. See product data table on p. 10 for footnotes.
3. The width of the upper wall should match the width of the lower wall.

Two-Storey Stacked WSW Product Data – Bottom Wall

Model No.	W (in.)	H (in.)	Anchor Bolts		Total Wall Weight (lb.)
			Qty.	Dia. (in.)	
WSW18x8	18	93¼	2	¾	165
WSW24x8	24	93¼	2	1	225
WSW18x9	18	105¼	2	¾	185
WSW24x9	24	105¼	2	1	245
WSW18x10	18	117¼	2	¾	205
WSW24x10	24	117¼	2	1	270
WSW18x11	18	129¼	2	¾	220
WSW24x11	24	129¼	2	1	295
WSW18x12	18	141¼	2	¾	240
WSW24x12	24	141¼	2	1	320

1. See product data table on p. 10 for footnotes.

Multi-Storey Connection Kit

Model No.	Contents
WSW-MSK12KT	(2) Holdowns with pre-attached bolts
WSW-MSK18KT	(2) Standard hex nuts and flat washers
WSW-MSK24KT	(1) LSL bearing block Installation instructions

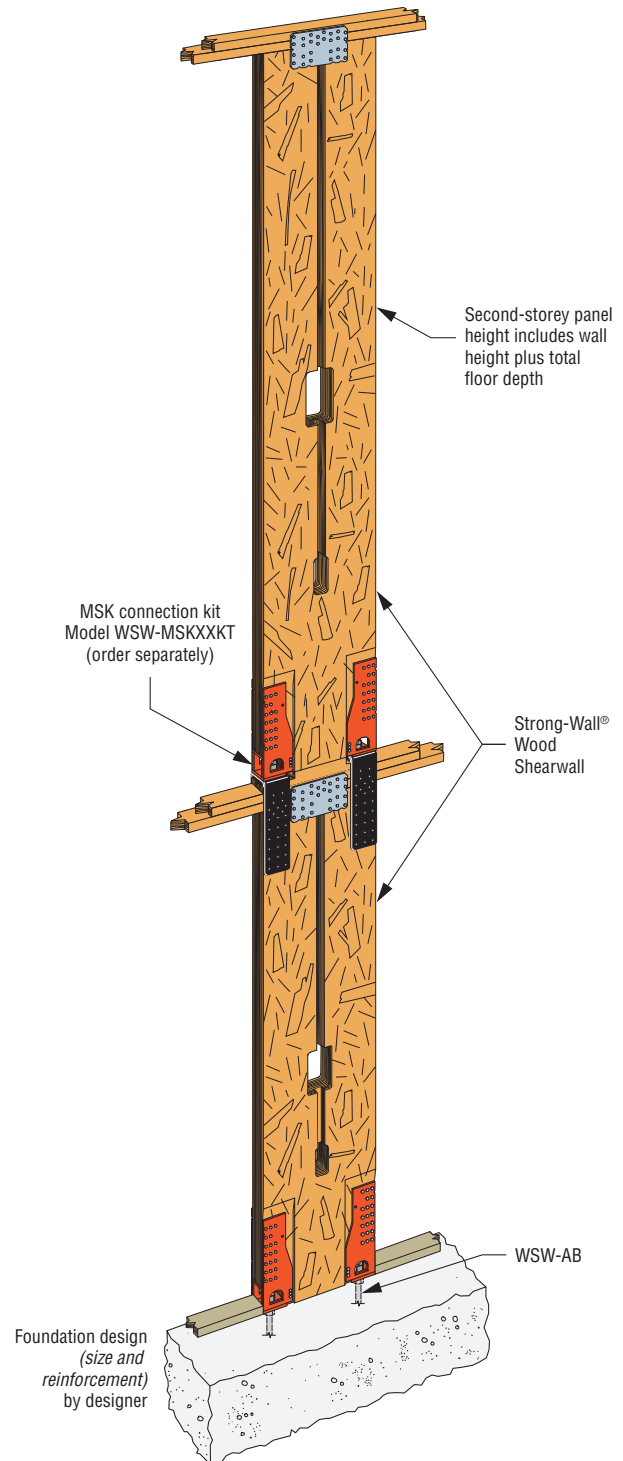

Two-Storey Stacked Installation

Two-Storey Stacked on Concrete Foundations

Installation

- All panels may be trimmed to a minimum of 74½". Trim height from top of panel only, do not trim from sides or bottom. Drilling holes in the Strong-Wall® Wood Shearwalls is not allowed except as shown on p. 36.
- Anchor-bolt nuts should be snug tight.
- Maximum shim thickness between the shearwall and the top plates or header is 7/8".
- Walls may also be used in 2x6 wall framing. Install the panel flush to the outside face of the framing and add furring to the opposite side.
- Standard top-of-wall connections install with nails.
- The second-storey panel must be the same width as the first-storey panel.
- When specifying the height of the second-storey panels, add the total floor height, including sheathing, to the wall height, then subtract 2". See h_3 definition on p. 19.

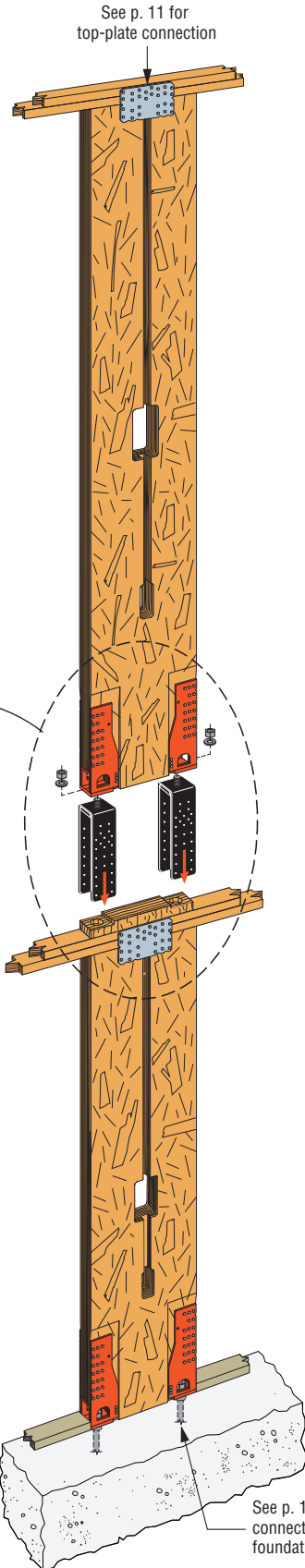

Two-Storey Stacked MSK Connection Details

Two-Storey Stacked Installation

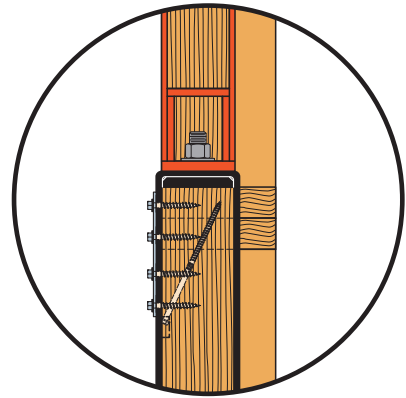

2x6 Framing Installation
Alternative top connection recommended.
See pp. 33 and 38 for details.

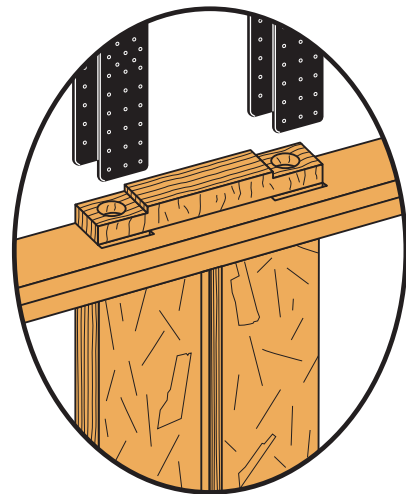

2x6 Framing Installation
Cut slots (1/4" wide max.) in the top plates to allow the MSK holdown to pass through. Do not notch the double top plates.

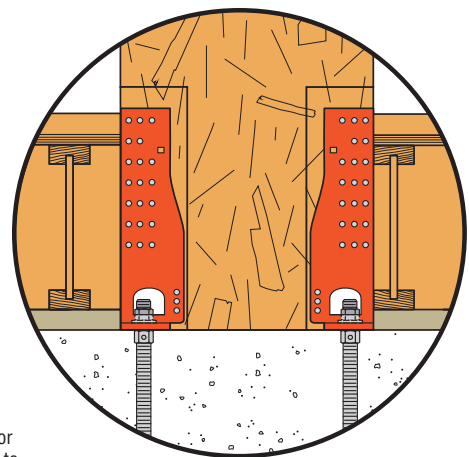

First-Storey Installation with Wood Floor System
Specify panel height from top of foundation to underside of top plates.

Two-Storey Stacked on Concrete Foundations

Strong-Wall® Wood Shearwall Second-Storey Walls — Stacked Application on Concrete Foundation

Strong-Wall Wood Shearwall Model No.	Width, W	Height, H	Factored Vertical Resistance, P _r	Factored Shear Resistance, V _r	Drift at V _r	Service Load at H/500
	in.	in.	lb.	lb.	in.	lb.
	mm	mm	kN	kN	mm	kN
WSW18x9	18	105.25	2000	1440	0.52	695
	457	2,673	8.90	6.41	13	3.09
WSW24x9	24	105.25	2000	2595	0.52	1265
	610	2,673	8.90	11.54	13	5.63
WSW18x10	18	117.25	2000	1320	0.57	630
	457	2,978	8.90	5.87	14	2.80
WSW24x10	24	117.25	2000	2365	0.57	1145
	610	2,978	8.90	10.52	14	5.09
WSW18x11	18	129.25	2000	1200	0.63	570
	457	3,283	8.90	5.34	16	2.54
WSW24x11	24	129.25	2000	2140	0.63	1030
	610	3,283	8.90	9.52	16	4.58
WSW18x12	18	141.25	2000	1080	0.69	505
	457	3,588	8.90	4.80	18	2.25
WSW24x12	24	141.25	2000	1910	0.69	915
	610	3,588	8.90	8.50	18	4.07

- Resistances include evaluation of bearing stresses on concrete foundation with compressive strength, $f'_c = 2900$ psi (20 MPa).
- Seismic design based on NBC 2015 using $R_d = 3.0$ and $R_o = 1.7$.
- High strength (HS) anchor bolts are required. See pp. 21–25 for anchor bolt information and anchorage solutions.
- Factored vertical resistance denotes the total maximum concentric vertical load permitted on the panel acting in combination with the factored shear resistance.
- Factored resistances and drift values may be interpolated for intermediate heights or vertical loads.
- Two-Storey Stacked panel combinations may consist of any height combination of equal width panels listed in these tables.
- A multi-storey kit (MSK) is required to attach the second-storey panel to first-storey panel.
- The designer must verify that the cumulative overturning moment at the base of the first-storey panel does not exceed the allowable base moment capacity as shown in the example on p. 20. The overturning base moment shall be determined using the following equation:

$$M_{OTr} = (V_{f1} \times h_1) + (V_{f2} \times h_2), \text{ where:}$$

M_{OTr} = Factored overturning base moment

V_{f1} = Factored shear load to first-storey panel

V_{f2} = Factored shear load to second-storey panel

h_1 = Height of first-storey panel

h_2 = Total assembly Height (h_1 + Height of second-storey panel + 5")

- Tabulated anchor tension values assume no resisting vertical load. Anchor tension loads at design shear values and including the effect of vertical load may be determined using the following equation:

$$T = M_{OTr} / B - P/2, \text{ where:}$$

T = Anchor tension load (lb.);

P = Applied vertical load (lb.);

M_{OTr} = Factored overturning moment, see Footnote 8

B = Moment arm (in.); 13.94" for WSW18, 18.94" for WSW24

- First-storey panel drift must comply with code drift limits; evaluate drift at the top of the first-storey panel using the following equations as applicable:

$$\Delta_{wind} = h_1^2 / K \times [(3 \times V_2 \times h_3) + (2 \times V_{base} \times h_1)], \text{ where:}$$

Δ_{wind} = Service level first-storey panel drift;

K = Stiffness of first-storey panel;

h_1 = First-storey panel height;

h_3 = Second-storey panel height;

V_2 = Applied service shear load to second-storey panel;

V_{base} = Sum of applied service shear loads to first-storey panel and second-storey panel

$$\Delta_{seismic} = h_1^2 / K \times [(3 \times V_{f2} \times h_3) + (2 \times V_{fbase} \times h_1)] \times R_d R_o, \text{ where:}$$

$\Delta_{seismic}$ = Factored level first-storey panel drift;

K = Stiffness of first-storey panel;

h_1 = First-storey panel height;

h_3 = Second-storey panel height;

V_{f2} = Factored shear load to second-storey panel;

V_{fbase} = Sum of applied factored shear loads to first-storey panel and second-storey panel;

$R_d R_o$ = Force modification factors

Strong-Wall® Wood Shearwall First-Storey Walls — Stacked Application on Concrete Foundation

Strong-Wall Wood Shearwall Model No.	Width, W	Height, H	Factored Vertical Resistance, P _r	Stiffness, K x 10 ⁹	Factored Base Moment Resistance, M _{OTr}	Anchor Tension at M _{OTr}
	in.	in.	lb.	lb.-in. ²	lb.-in.	lb.
	mm	mm	kN	kN-mm ²	kN-m	kN
WSW18x8	18	93.25	4000	9.7	243385	17465
	457	2369	17.79	27.8	27.50	77.67
WSW24x8	24	93.25	4000	19.4	485365	25630
	610	2369	17.79	55.7	54.84	114.00
WSW18x9	18	105.25	4000	10.3	234180	16800
	457	2673	17.79	29.6	26.46	74.74
WSW24x9	24	105.25	4000	21.5	480465	25370
	610	2673	17.79	61.7	54.28	112.85
WSW18x10	18	117.25	4000	11.6	235675	16910
	457	2978	17.79	33.3	26.63	75.21
WSW24x10	24	117.25	4000	22.6	454345	23990
	610	2978	17.79	64.9	51.33	106.72
WSW18x11	18	129.25	4000	12.5	228775	16415
	457	3283	17.79	35.9	25.85	73.01
WSW24x11	24	129.25	4000	24.8	453020	23920
	610	3283	17.79	71.2	51.18	106.40
WSW18x12	18	141.25	4000	12.8	216115	15505
	457	3588	17.79	36.7	24.42	68.97
WSW24x12	24	141.25	4000	26.5	443525	23420
	610	3588	17.79	76.1	50.11	104.17

Two-Storey Stacked on Concrete Foundations

Designing for Cumulative Overturning Forces

In multi-storey structures, shear and the associated overturning forces due to seismic and wind requirements must be carried down to the foundation by the building's lateral-force-resisting system. These forces are cumulative over the height of the building, and shear forces applied at the second or third levels of a structure will generate much larger base overturning moments than the same shears applied at the first storey. If cumulative overturning is not considered, the design may result in forces several times higher than the capacity of the lower wall, anchor bolts and foundation anchorage.

When specifying two-storey stacked applications, analysis should be performed by following these steps.

1. Analyze the structure to determine the shear forces at each floor. The detail to the right illustrates the forces developed in a two-storey stacked application. Then calculate the cumulative factored overturning moment (M_{OTf}), based on the storey heights and applied shear forces at each storey, as follows:

$$M_{OTf} = (V_{f1} \times h_1) + (V_{f2} \times h_2)$$
2. Select the first-storey panel and ensure that the factored base moment resistance exceeds the overturning moment (M_{OTf}).
3. Check the applicable second-storey panel with the same width as the first-storey panel and verify that the factored second-storey shear resistance exceeds the applied second-storey shear force.
4. Check the first-storey panel drift.

Given

- Normal importance category
- First-storey wall height = 9 ft.
- Second-storey wall height = 8 ft.
- Joist height = 11 $\frac{1}{8}$ in.

Design Loads

Wind

- Factored: $V_{f1} = 700$ lb., $V_{f2} = 490$ lb., $V_{fbase} = 1190$ lb.
- Service: $V_1 = 350$ lb., $V_2 = 200$ lb., $V_{base} = 550$ lb.

Seismic

- Factored: $V_{f1} = 500$ lb., $V_{f2} = 250$ lb., $V_{fbase} = 750$ lb.

Ultimate Limit States Design

1. Calculate overturning moment

$$M_{OTf} = V_{f1} h_1 + V_{f2} h_2 = 700 (105.25) + 490 (213.25) = 178168 \text{ lb.-in.}$$
2. Select WSW18x9 at the first-storey

$$M_{OTr} = 234180 \text{ lb.-in.} > M_{OTf} : \text{OK}$$
3. Check capacity of second-storey WSW18x9

$$V_r = 1440 \text{ lb.} > V_{f2} : \text{OK}$$

Serviceability Limit States Design

- 4a. Check first-storey panel drift under wind loading

Drift limit at $H/500 = 105.25/500 = 0.21$ in.

$$\Delta_{wind} = \frac{h_1^2}{K} (3V_2 h_3 + 2V_{base} h_1) = \frac{105.25^2}{10.3 \times 10^9} (3(200)(103) + 2(550)(105.25)) = 0.19 \text{ in.}$$

$\Delta_{wind} = 0.21 \text{ in.} > 0.19 \text{ in.} : \text{OK}$

- 4b. Check first-storey panel drift under seismic loading

Maximum allowable drift = $0.025H = 0.025 \times 105.25 = 2.63$ in.

$$\Delta_{seismic} = \frac{h_1^2}{K} (3V_{f2} h_3 + 2V_{fbase} h_1) R_d R_o = \frac{105.25^2}{10.3 \times 10^9} (3(250)(103) + 2(750)(105.25)) \times 3.0 \times 1.7 = 1.29 \text{ in.}$$

$\Delta_{seismic} = 2.63 \text{ in.} > 1.29 \text{ in.} : \text{OK}$

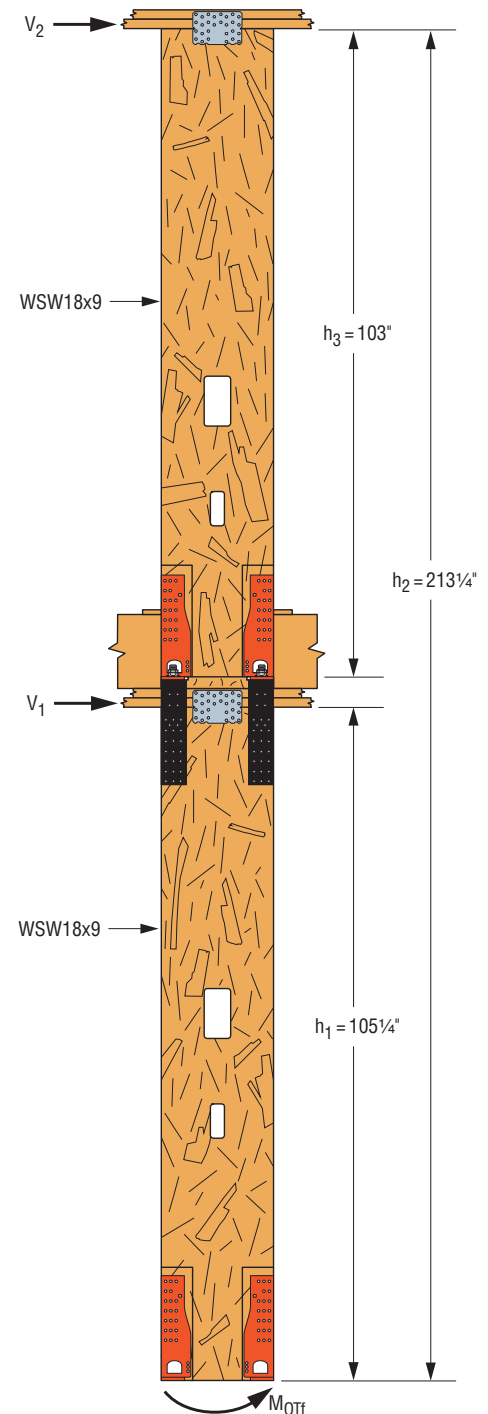

Design Example

Anchorage Solutions

WSW-AB Anchor Bolts

WSW-AB anchor bolts in 7/8" and 1" diameters offer flexibility to meet specific project demands. Inspection is easy; the head is stamped with a "No-Equal" symbol for identification, bolt length, bolt diameter, and "HS" for "High Strength."

Material: High Strength (HS) ASTM A449

An additional nut for template installation is provided with each WSW-AB.

Strong-Wall Wood Shearwall Width (in.)	Model No.	Dia. (in.)	Total Length (in.)	l_e (in.)
12 and 18	WSW-AB7/8x24HS	7/8	24	20
	WSW-AB7/8x30HS	7/8	30	26
	WSW-AB7/8x36HS	7/8	36	32
24	WSW-AB1x24HS	1	24	20
	WSW-AB1x30HS	1	30	26
	WSW-AB1x36HS	1	36	32

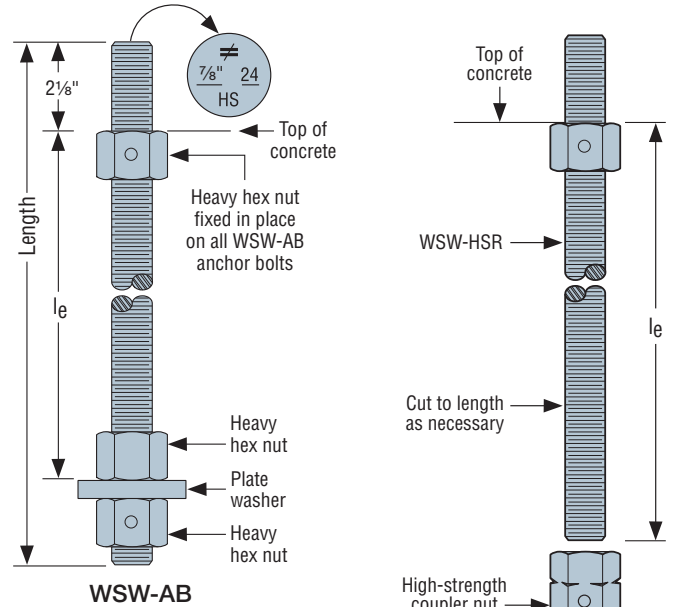

WSW-HSR Extension Kit

WSW-HSR allows for anchorage in tall stemwall applications where full embedment of a WSW-AB into the footing is required. The head is stamped for identification like a WSW-AB. Kit includes ASTM A449 high-strength rod with heavy hex nut fixed in place and high-strength coupler nut. Do not use in place of WSW-AB.

Strong-Wall Wood Shearwall Width (in.)	Model No.	Dia. (in.)	Total Length (in.)	l_e (in.)
12 and 18	WSW-HSR7/8x24KT	7/8	24	22
	WSW-HSR7/8x36KT	7/8	36	34
24	WSW-HSR1x24KT	1	24	22
	WSW-HSR1x36KT	1	36	34

Total l_e = WSW-HSR l_e + WSW-AB l_e + 2 1/8"

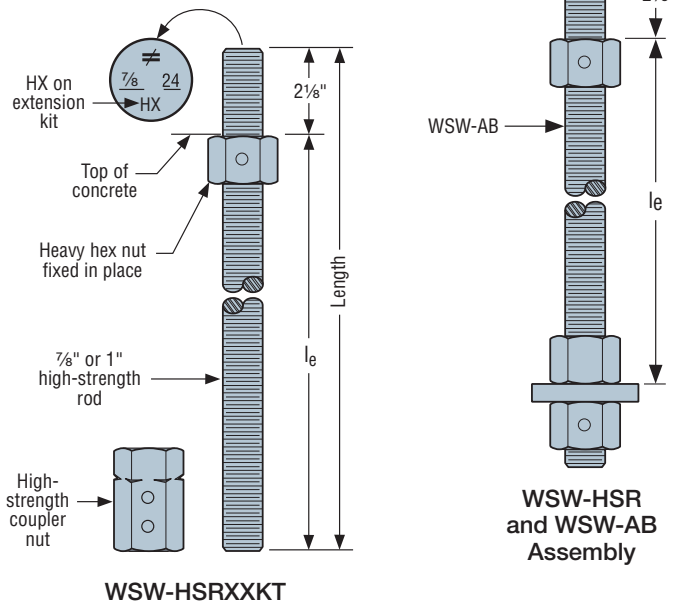

Strong-Wall® Wood Shearwall Tension Anchorage Solutions

Design Criteria	Concrete Condition	Anchor Bolt Model			
		WSW-AB7/8HS		WSW-AB1HS	
		W	d_e	W	d_e
		in.	in.	in.	in.
		mm	mm	mm	mm
Wind and Seismic	Cracked	41	14	48	16
		1041	356	1219	406
	Uncracked	36	12	42	14
		914	305	1,067	356

1. Anchorage designs conform to CSA Standard A23.3-14 Annex D with no supplementary reinforcement for cracked and uncracked concrete as noted and assume minimum $f'_c = 2900$ psi (20 MPa).
2. High Strength (HS) anchor bolts required for solutions.
3. Anchorage solutions applicable for both wind and seismic applications.
4. Refer to slab on grade, curb, stemwall and interior footing details for W and d_e .
5. Foundation dimensions are for anchorage only. Foundation design (size and reinforcement) by others. The registered design professional may specify alternate embedment, footing size or anchor bolt.

Anchorage Solutions

Strong-Wall® Wood Shearwall Shear Anchorage

Foundation shear reinforcement to resist shear forces from Strong-Wall Wood Shearwalls located at the edge of concrete is shown in the table below.

Strong-Wall Wood Shearwall Shear Anchorage Solutions

Strong-Wall Wood Shearwall Model No.	L_T or L_n (in.)	Wind and Seismic	
		Shear Reinforcement	Min. Curb / Stemwall Width (in.)
WSW12	10¼	(1) 10M hairpin	8
WSW18	15	(1) 10M hairpin	8
WSW24	19	(2) 10M hairpin	8

1. Anchorage designs conform to CSA Standard A23.3-14 Annex D and assume minimum $f'_c = 2900$ psi (20 MPa). See p. 21 for tension anchorage.
2. Shear reinforcement is not required for interior foundation applications (panel installed away from edge of concrete), or braced wall panel applications.
3. The registered design professional may specify alternate shear anchorage.
4. Minimum shear reinforcement grade 400 MPa.

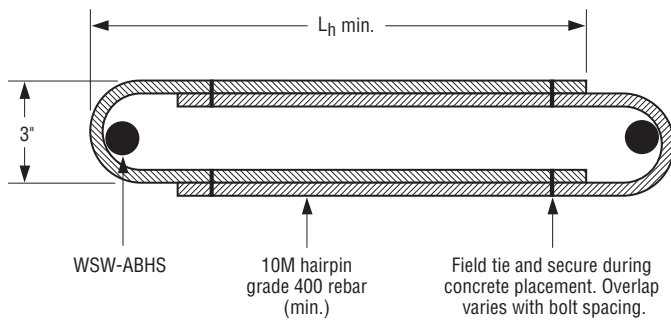

Hairpin Shear Reinforcement

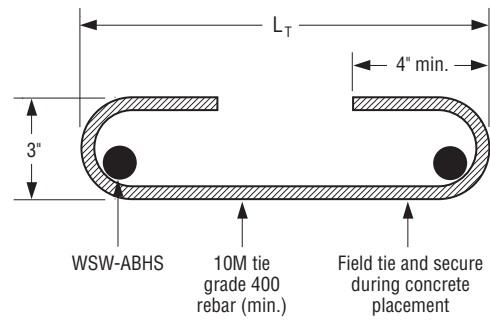

Tie Shear Reinforcement

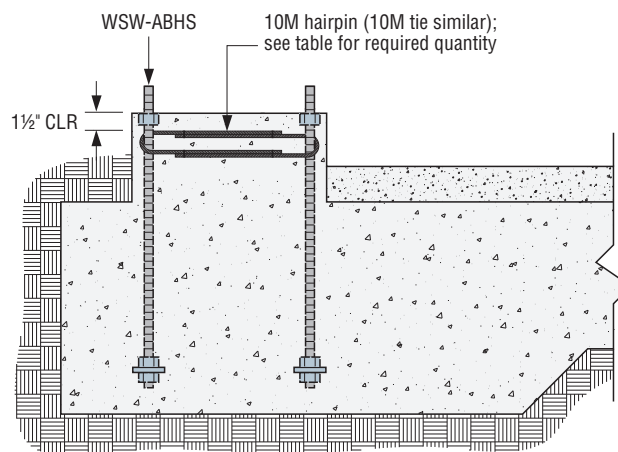

Hairpin Installation
(Garage curb shown, other footing types similar)

Anchorage Solutions

Curb or Stemwall Installation

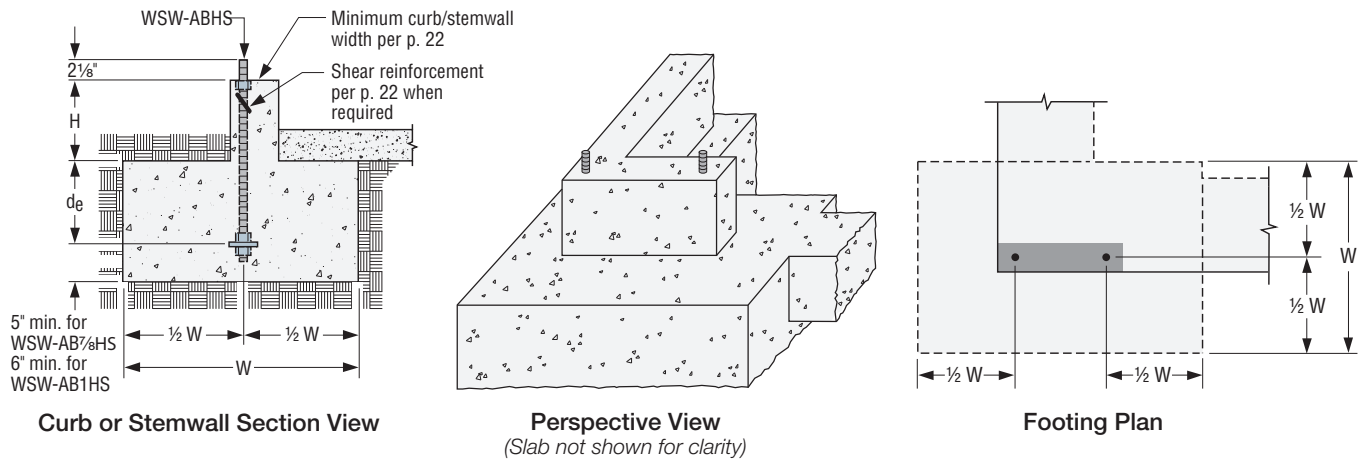

Slab-on-Grade Installation

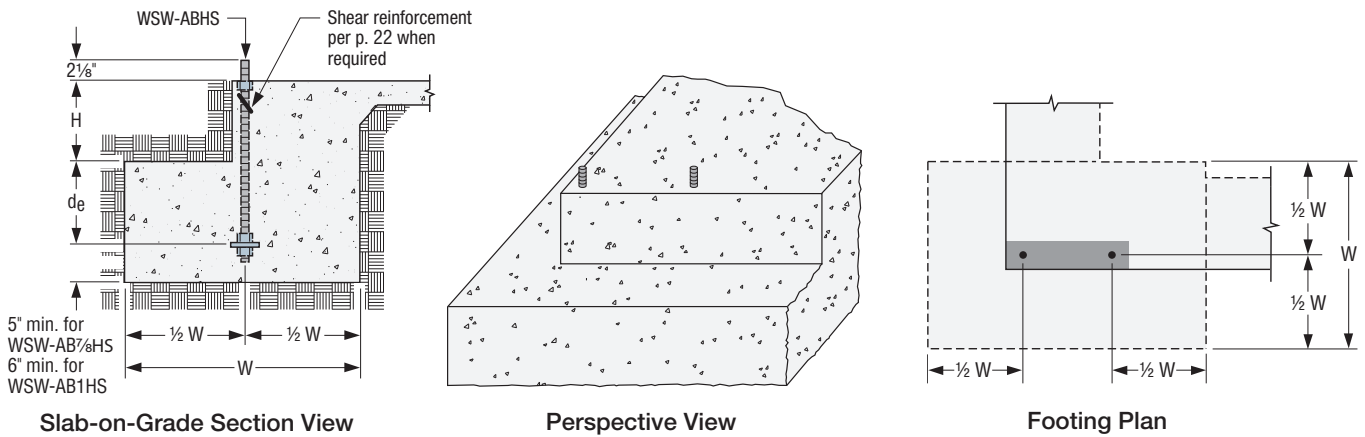

Brick Ledge Installation

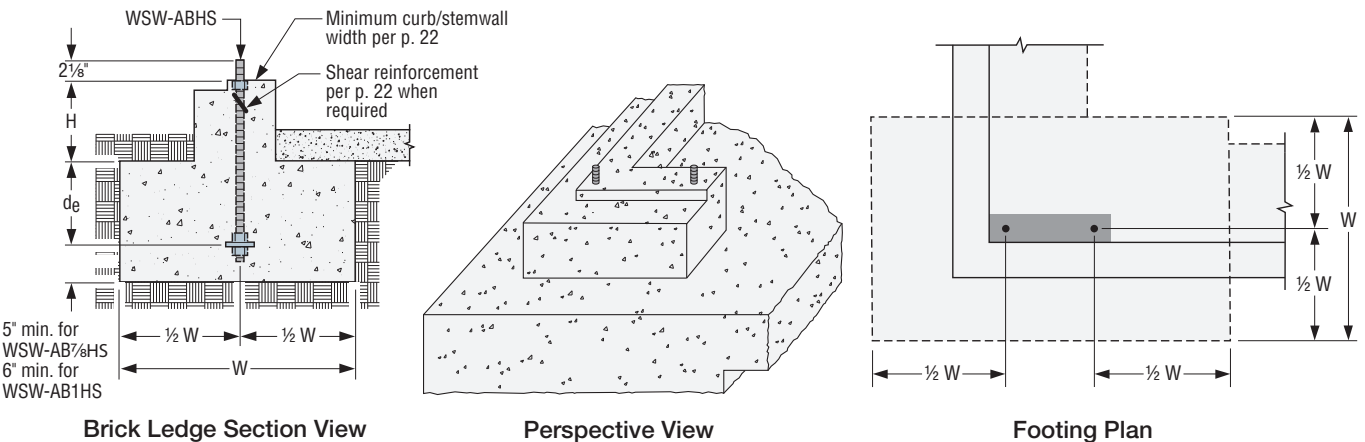

Anchorage Solutions General Notes

1. The designer may specify alternate embedment, footing size or bolt grade.
2. Footing dimensions and rebar requirements are for anchorage only.

Foundation design
(size and reinforcement) by designer.

Anchorage Solutions

Interior Installation

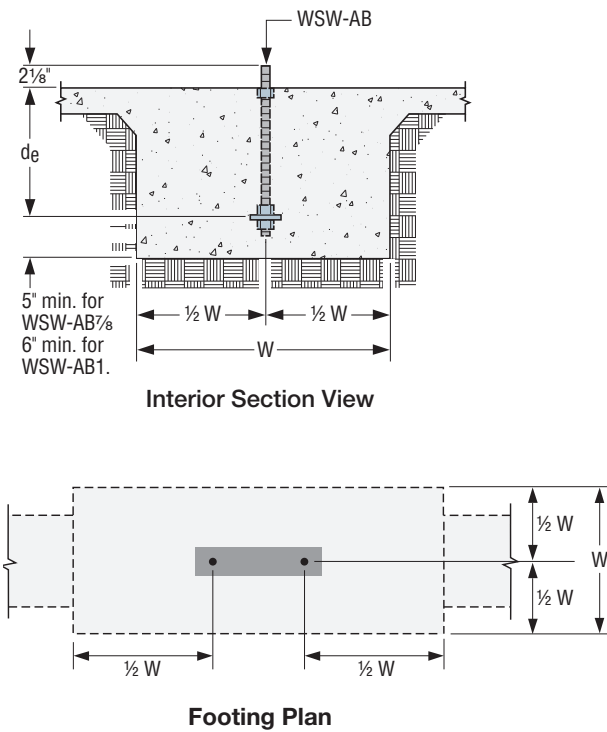

Stemwall Extension Installation

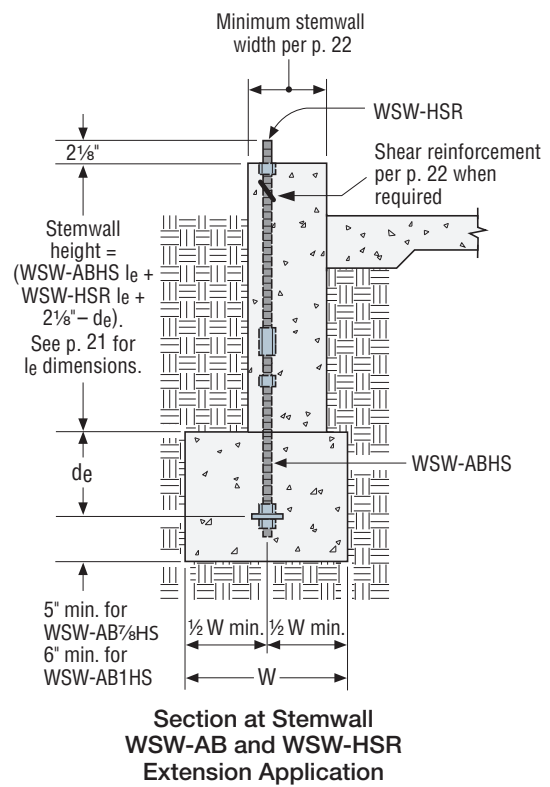

Anchorage Solutions General Notes

1. The designer may specify alternate embedment, footing size or bolt grade.
2. Footing dimensions and rebar requirements are for anchorage only.

Strong-Wall® Wood Shearwall Anchor Bolt Layout

Wall Model No.	Distance from Center to Center of WSW-ABs S (in.)
WSW12	8 $\frac{1}{8}$
WSW18	14
WSW24	20

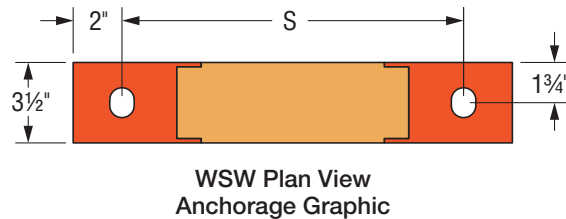

Anchorage Solutions

Simpson Strong-Tie has developed a reusable anchor-bolt template for common foundation types for the Strong-Wall® Wood Shearwalls. The templates help to accurately locate the newly-designed WSW-AB preassembled anchor bolts, which simplifies installation and greatly reduces the chances of voids in the concrete.

Strong-Wall Wood Shearwall Anchor-Bolt Templates

Strong-Wall Wood Shearwall Model No.	Width (in.)	Strong-Wall Wood Shearwall Template Model		
		Reversible	Panel Form	Brick Ledge
WSW12	12½	WSW-RT12	WSW-RTPF12	WSW-RTBL12
WSW18	18	WSW-RT18	WSW-RTPF18	WSW-RTBL18
WSW24	24	WSW-RT24	WSW-RTBL24	

1. Templates are recommended and are required in some jurisdictions.
2. Foundation design by the designer.

An additional nut for template installation is provided with each WSW-AB.

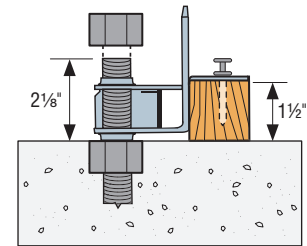
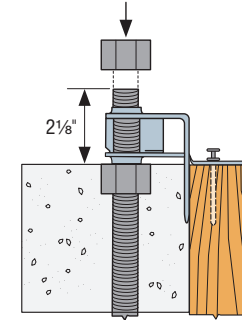

Anchor Bolt Height

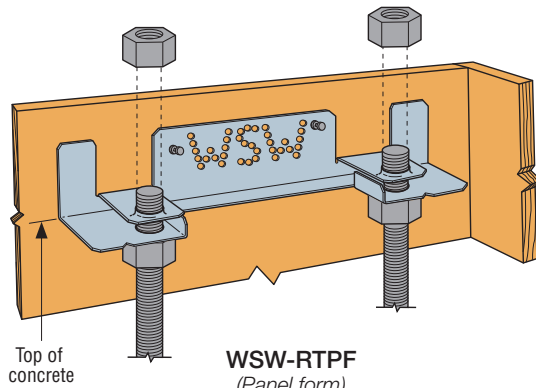

WSW-RTPF
(Panel form)
US Patent 7,445,192

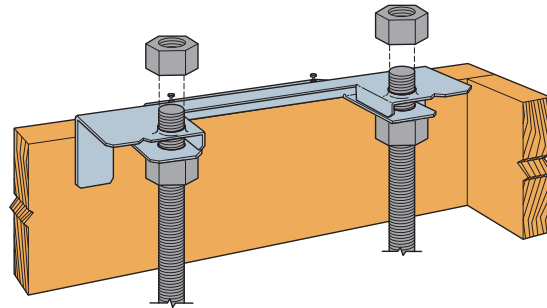

WSW-RT Exterior Installation*
US Patent 7,445,192

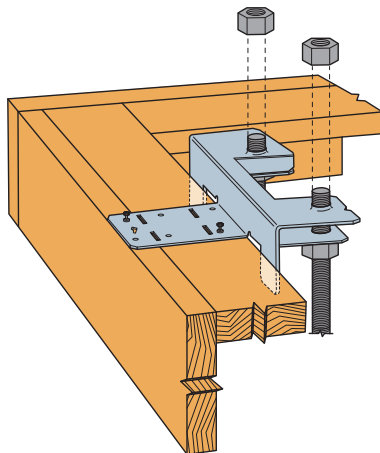

WSW-RTBL
(Brick ledge)
US Patent 7,445,192

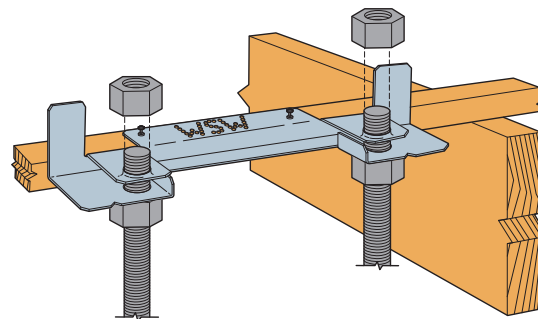

WSW-RT Interior Installation*
US Patent 7,445,192

*WSW-RT templates are reversible. Use the same template for interior or exterior applications.

Installation Details

Anchorage and Installation Details

Simpson Strong-Tie offers complete structural details in order to make the specification and installation easier for the Strong-Wall® Wood Shearwalls. Versions of these details are available three ways:

- **Online at strongtie.com:** Full-size 24" x 36" detail sheets may be downloaded at strongtie.com in DWG, DXF and PDF formats.
- **Call (800) 999-5099:** Full-size, printed sheets may be requested from our regional branches at no charge.
- **In this catalogue:** Smaller versions are shown here for easy reference. Details are numbered to coincide with full-size sheets, although some have been left out to eliminate redundancy.

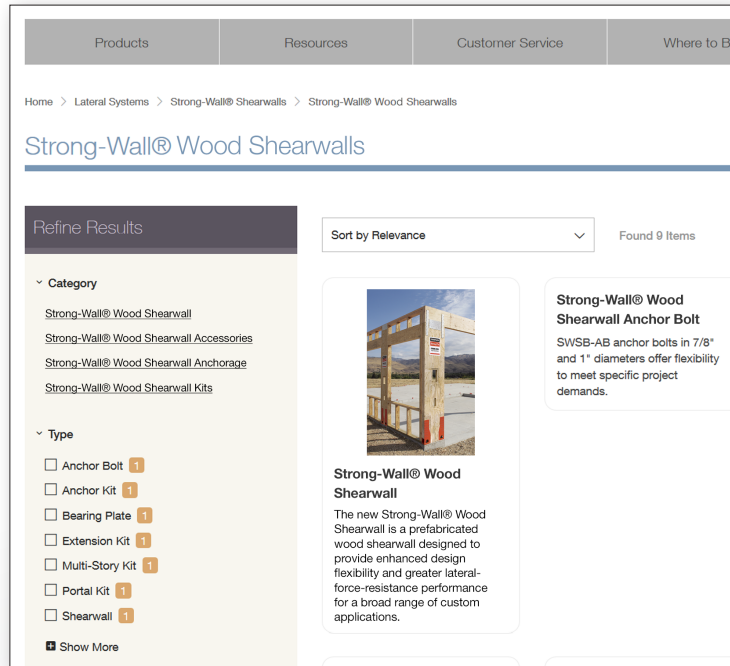

In This Section:

Strong-Wall Wood Shearwall
Anchorage and Installation Details

pp. 27–41

(Sheets WSW1.2, WSW2,
WSW3 and WSW4)

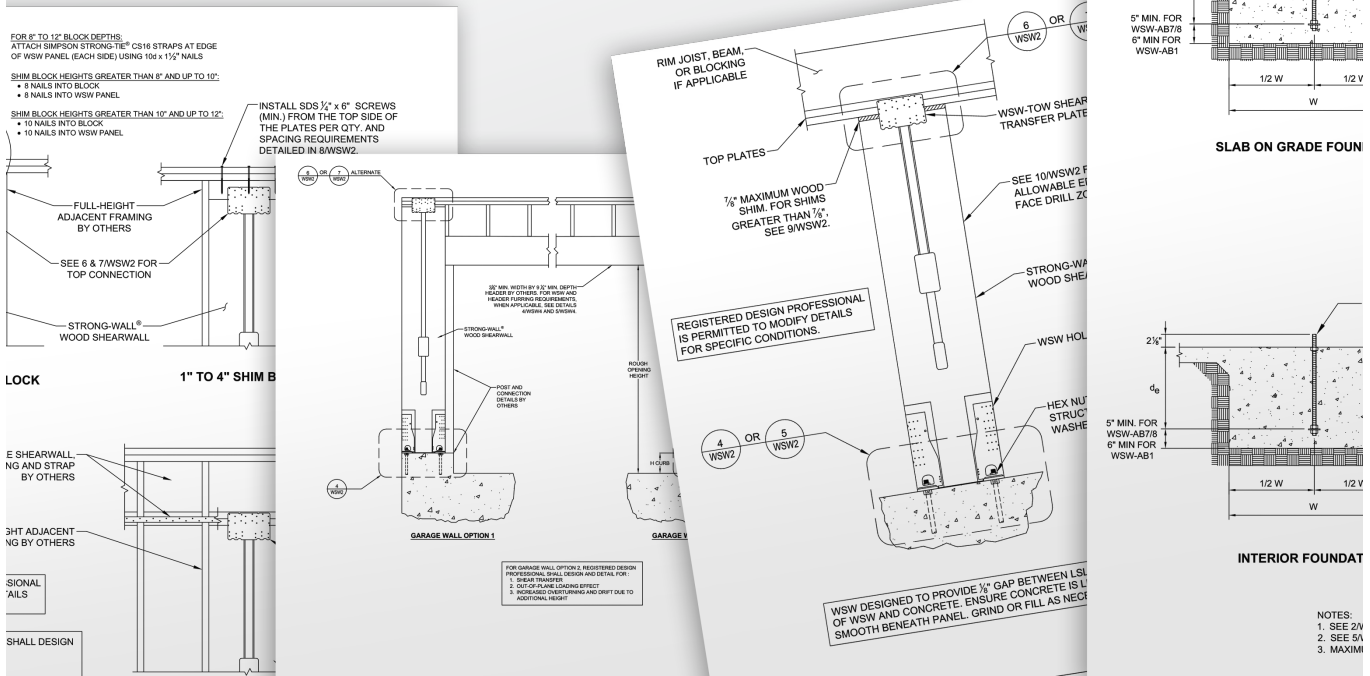

Installation Details

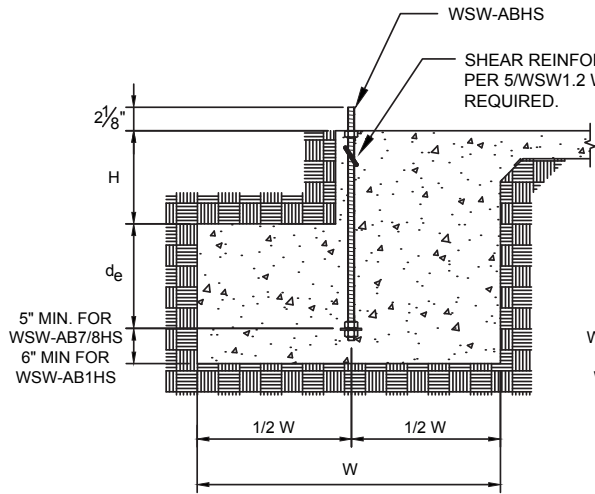

SLAB ON GRADE FOUNDATION

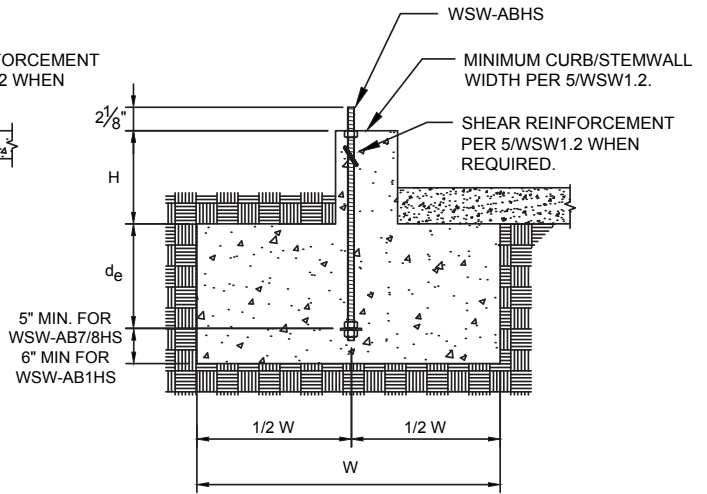

CURB OR STEMWALL FOUNDATION

REGISTERED DESIGN PROFESSIONAL IS PERMITTED TO MODIFY DETAILS FOR SPECIFIC CONDITIONS.

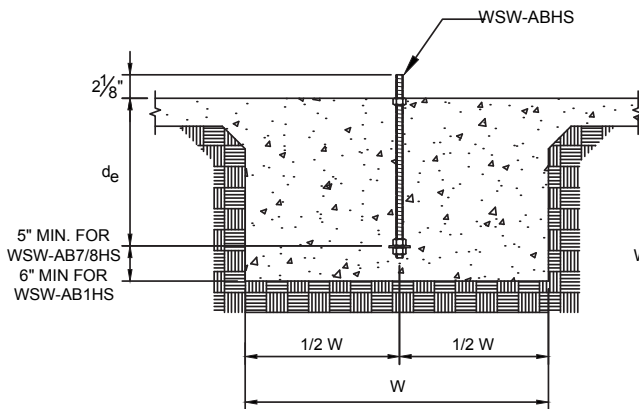

INTERIOR FOUNDATION

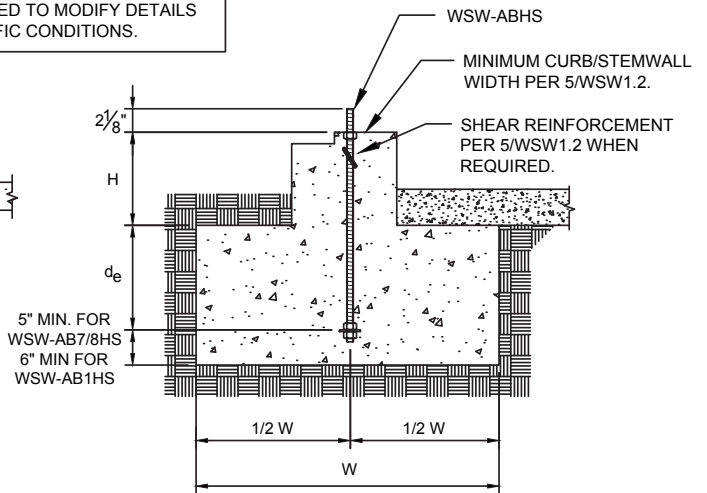

BRICK LEDGE FOUNDATION

NOTES:

1. SEE 2/WSW1.2 FOR DIMENSIONS AND ADDITIONAL NOTES.
2. SEE 5/WSW1.2 FOR SHEAR REINFORCEMENT WHEN REQUIRED.
3. MAXIMUM $H = l_e - d_e$. SEE 3/WSW1.2 AND 4/WSW1.2 FOR l_e .

Installation Details

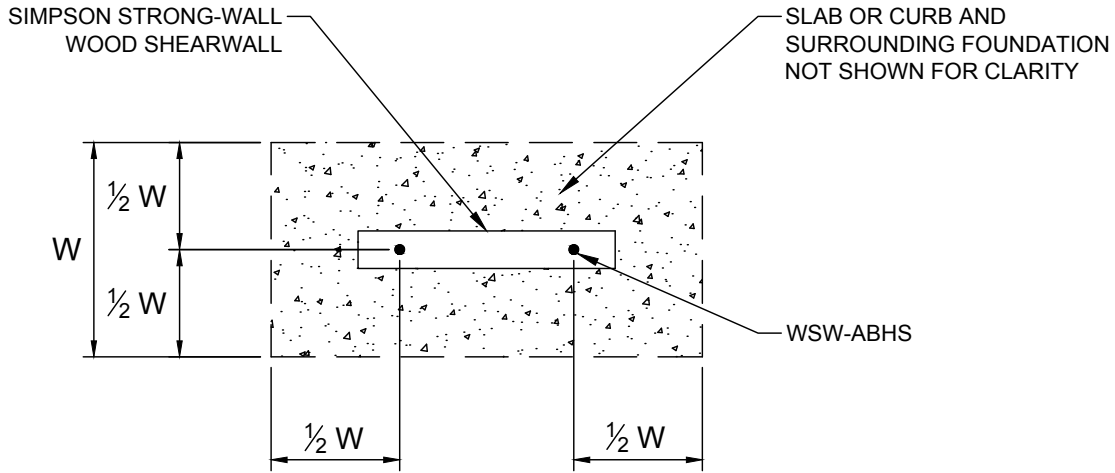

SEE TABLE BELOW FOR DIMENSIONS

FOUNDATION PLAN VIEW

WSW ANCHORAGE SOLUTIONS FOR 2,900 PSI CONCRETE					
DESIGN CRITERIA	CONCRETE CONDITION	ANCHOR BOLT MODEL			
		WSW-AB7/8HS		WSW-AB1HS	
		W	d _e	W	d _e
		in.	in.	in.	in.
		mm	mm	mm	mm
WIND AND SEISMIC	CRACKED	41	14	48	16
		1041	356	1219	406
	UNCRAKED	36	12	42	14
		914	305	1067	356

NOTES

1. ANCHORAGE DESIGNS CONFORM TO CSA STANDARD A23.3-14 ANNEX D WITH NO SUPPLEMENTARY REINFORCEMENT FOR CRACKED AND UNCRACKED CONCRETE AS NOTED AND ASSUME MINIMUM 2900 psi (20 MPa) CONCRETE..
2. HIGH STRENGTH (HS) ANCHOR BOLTS REQUIRED FOR SOLUTIONS.
3. ANCHORAGE SOLUTIONS APPLICABLE FOR BOTH WIND AND SEISMIC APPLICATIONS.
4. FOUNDATION DIMENSIONS ARE FOR ANCHORAGE ONLY. FOUNDATION DESIGN (SIZE AND REINFORCEMENT) BY OTHERS. THE REGISTERED DESIGN PROFESSIONAL MAY SPECIFY ALTERNATE EMBEDMENT, FOOTING SIZE OR ANCHOR BOLT.
5. REFER TO 1/WSW1.2 FOR d_e.

Installation Details

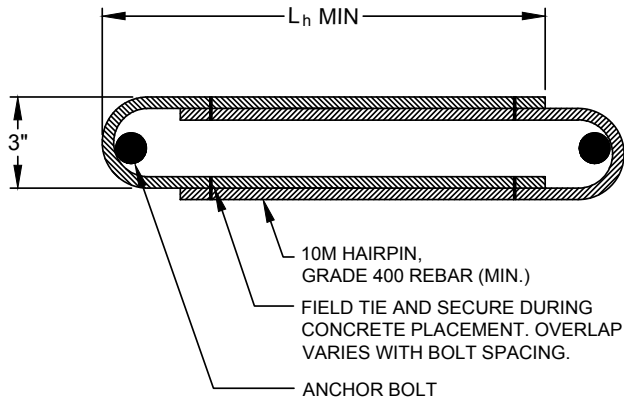

HAIRPIN SHEAR REINFORCEMENT

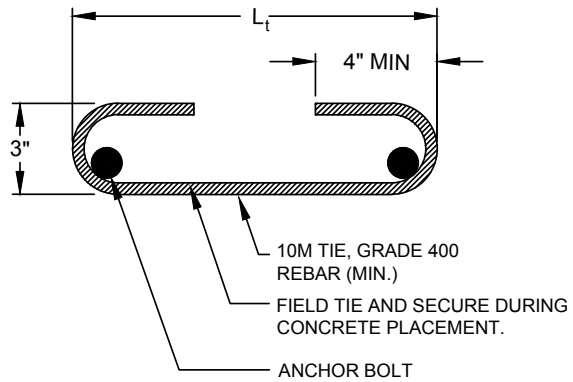

TIE SHEAR REINFORCEMENT

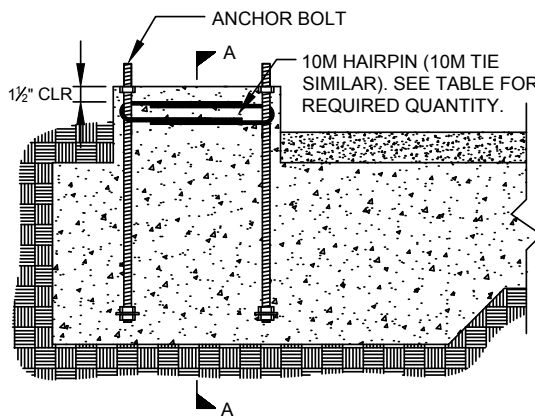

HAIRPIN INSTALLATION
(GARAGE CURB SHOWN. OTHER FOOTING TYPES SIMILAR.)

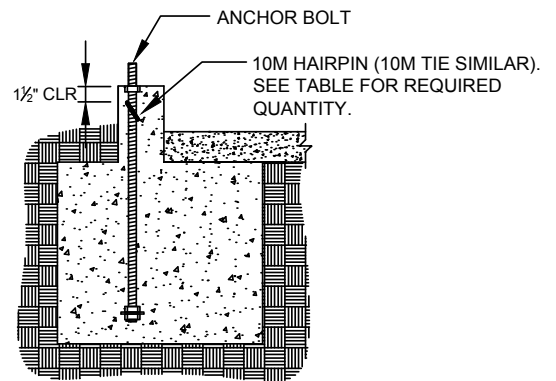

SECTION A-A

REGISTERED DESIGN PROFESSIONAL IS PERMITTED TO MODIFY DETAILS FOR SPECIFIC CONDITIONS.

STRONG-WALL® WOOD SHEARWALL SHEAR ANCHORAGE			
MODEL NO.	L _t OR L _h (in.)	WIND AND SEISMIC	
		SHEAR REINFORCEMENT	MINIMUM CURB/ STEMWALL WIDTH (in.)
WSW12	10¼	(1) 10M HAIRPIN	8
WSW18	15	(1) 10M HAIRPIN	8
WSW24	19	(2) 10M HAIRPINS	8

NOTES:

1. ANCHORAGE DESIGNS CONFORM TO CSA STANDARD A23.3-14 ANNEX D AND ASSUME MINIMUM 2,900 psi (20 Mpa) CONCRETE.
2. SHEAR REINFORCEMENT IS NOT REQUIRED FOR INTERIOR FOUNDATION APPLICATIONS (PANEL INSTALLED AWAY FROM EDGE OF CONCRETE), OR BRACED WALL PANEL APPLICATIONS.

Installation Details

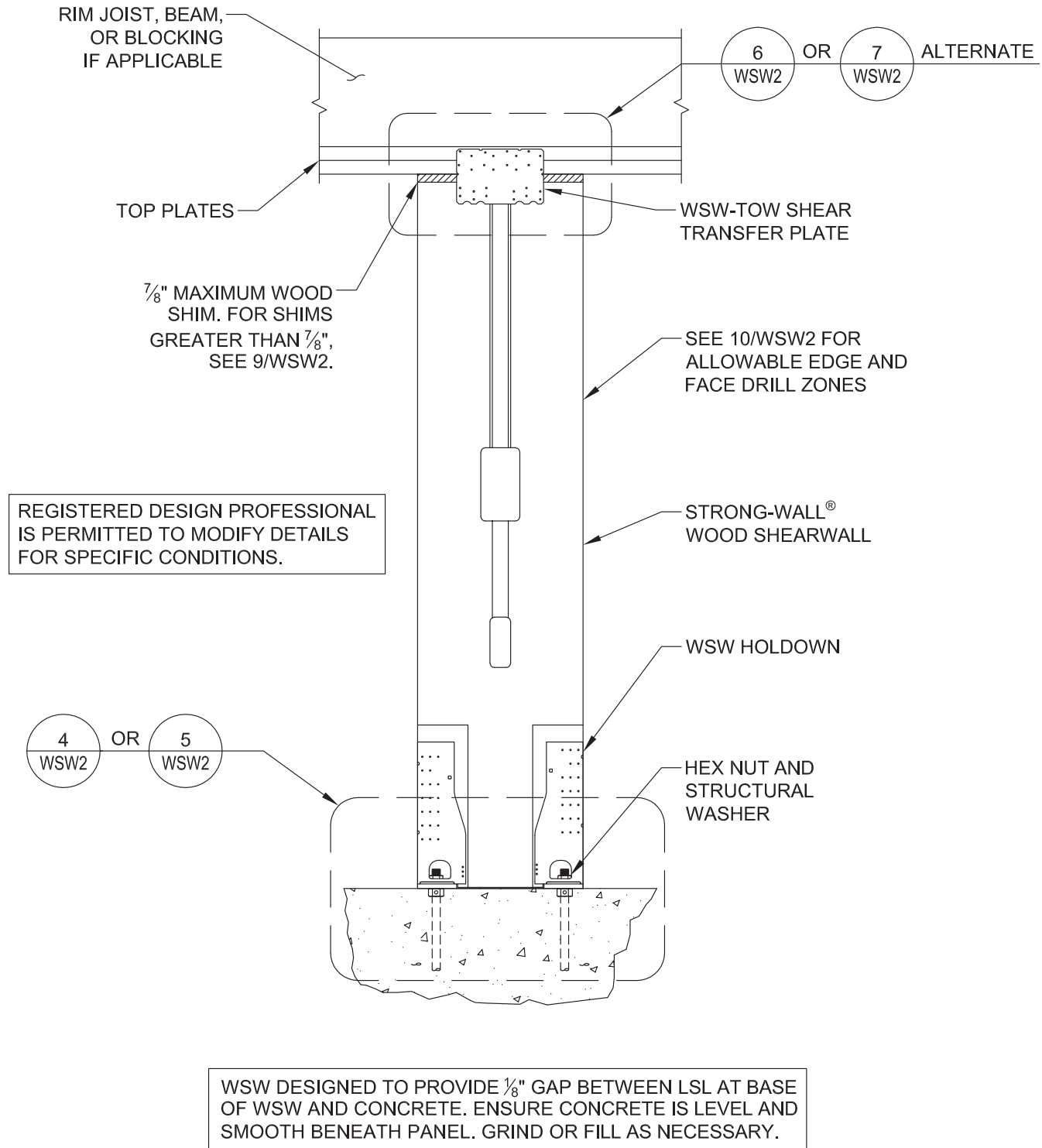

© 2021 Simpson Strong-Tie Company Inc. C-L-WSWCAN21

GARAGE HEADER ROUGH OPENING HEIGHT		
MODEL NO.	H CURB	ROUGH OPENING HEIGHT
WSW12x7 WSW18x7 WSW24x7	5½"	6'-11½"
WSW12x7.5 WSW18x7.5 WSW24x7.5	6"	7'-0"
WSW12x8 WSW18x8 WSW24x8	0"	7'-1½"
	5½"	8'-2¼"
	6"	8'-3¼"

1. IF REQUIRED ROUGH OPENING HEIGHT EXCEEDS TABLE VALUE, SPECIFY NEXT TALLER PANEL AND TRIM AS NECESSARY. THE STRONG-WALL® WOOD SHEARWALL MAY BE TRIMMED TO A MINIMUM HEIGHT OF 74½".
2. FURRING DOWN GARAGE HEADER MAY BE REQUIRED FOR CORRECT ROUGH OPENING HEIGHT.

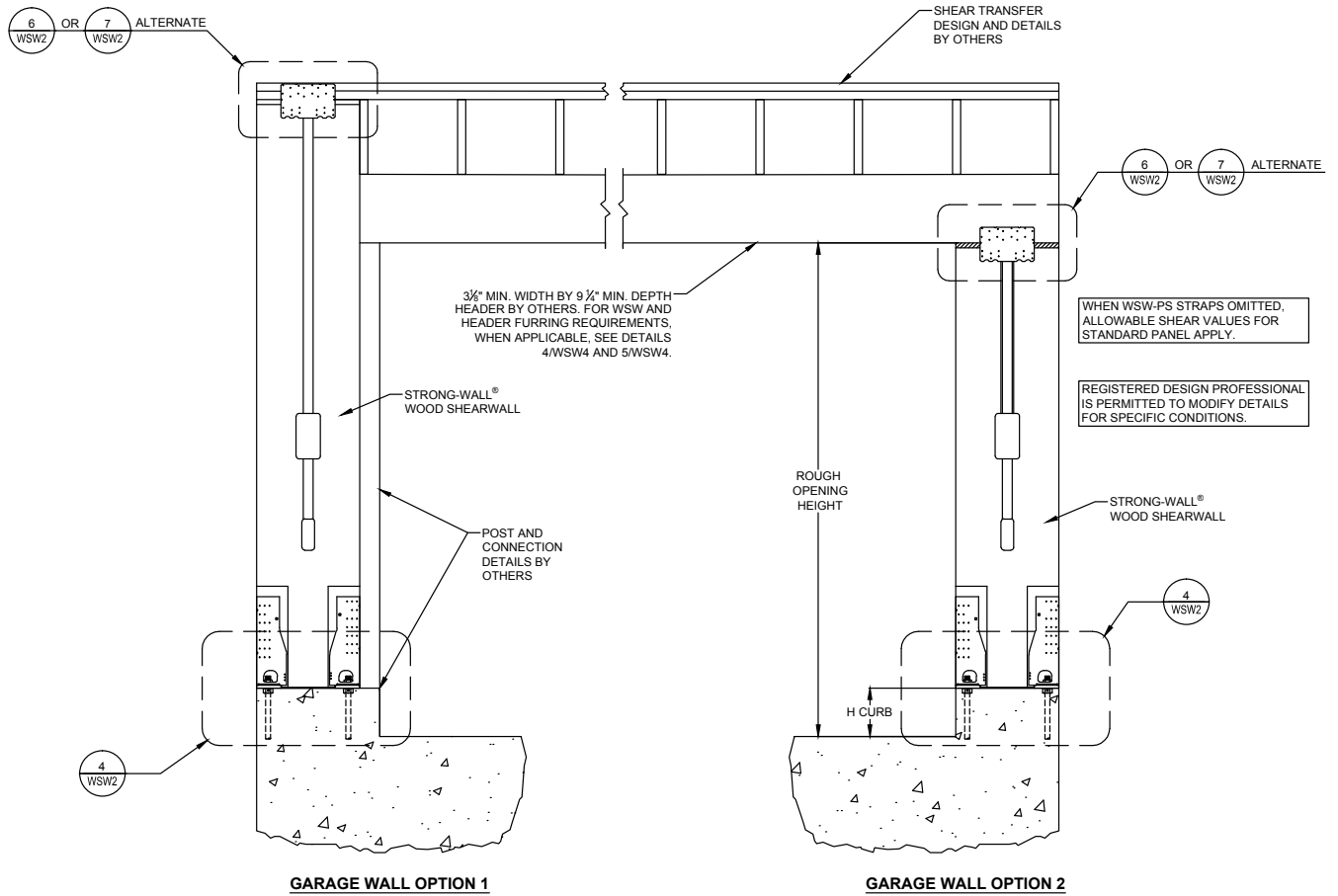

FOR GARAGE WALL OPTION 2, REGISTERED DESIGN PROFESSIONAL SHALL DESIGN AND DETAIL FOR:

1. SHEAR TRANSFER
2. OUT-OF-PLANE LOADING EFFECT
3. INCREASED OVERTURNING AND DRIFT DUE TO ADDITIONAL HEIGHT

© 2021 Simpson Strong-Tie Company Inc. C-L-WSWCAN21

Installation Details

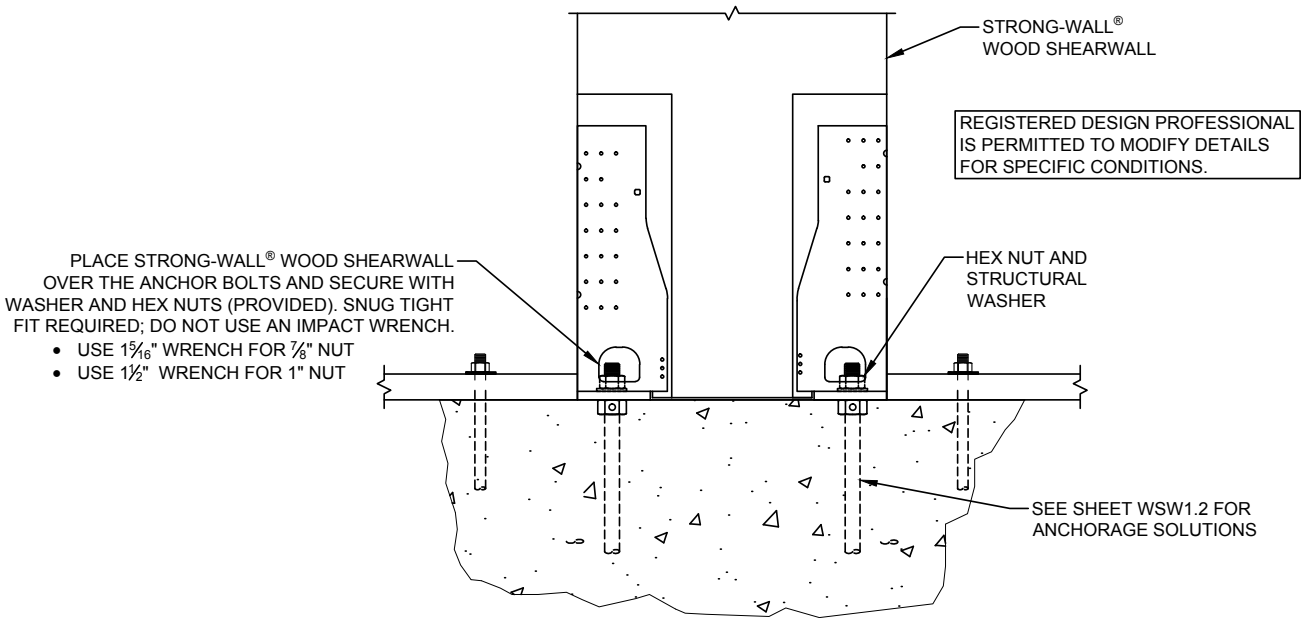

STANDARD INSTALLATION BASE CONNECTION

4/WSW2

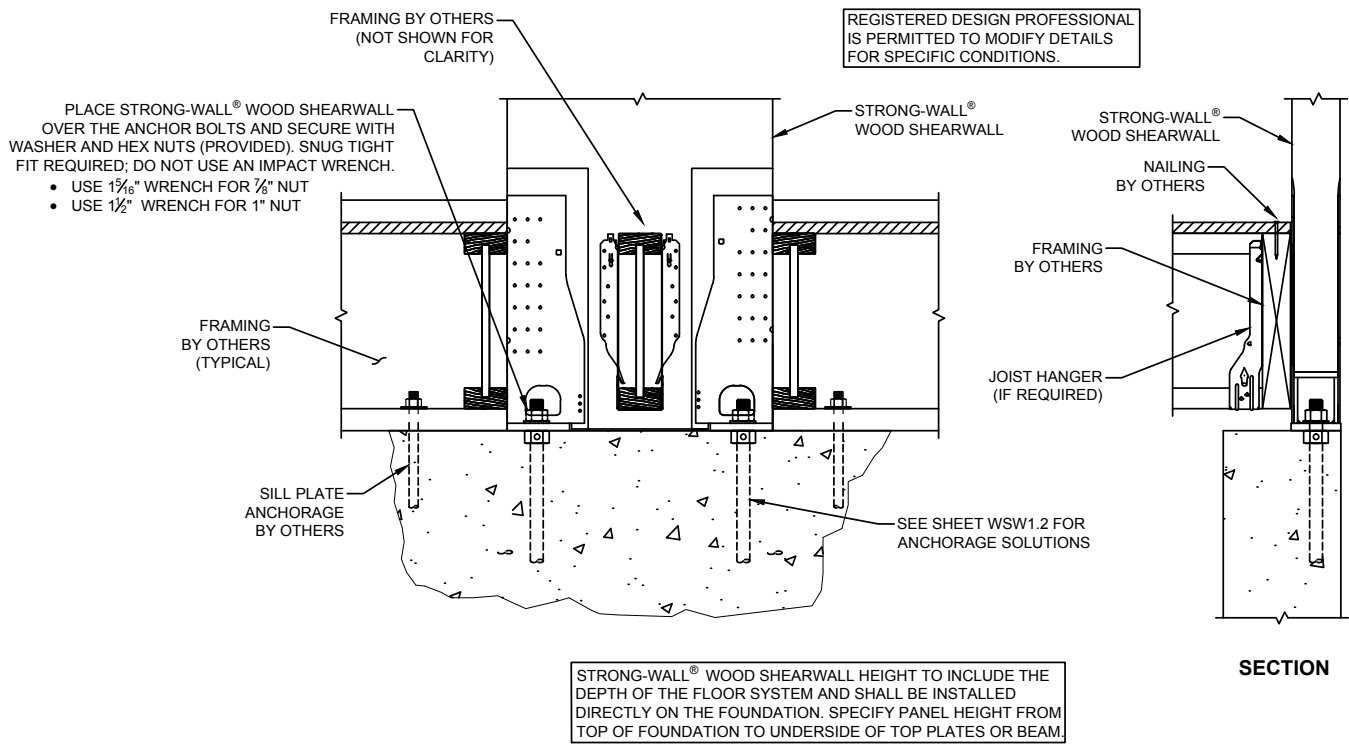

WOOD FLOOR SYSTEM BASE CONNECTION

5/WSW2

Installation Details

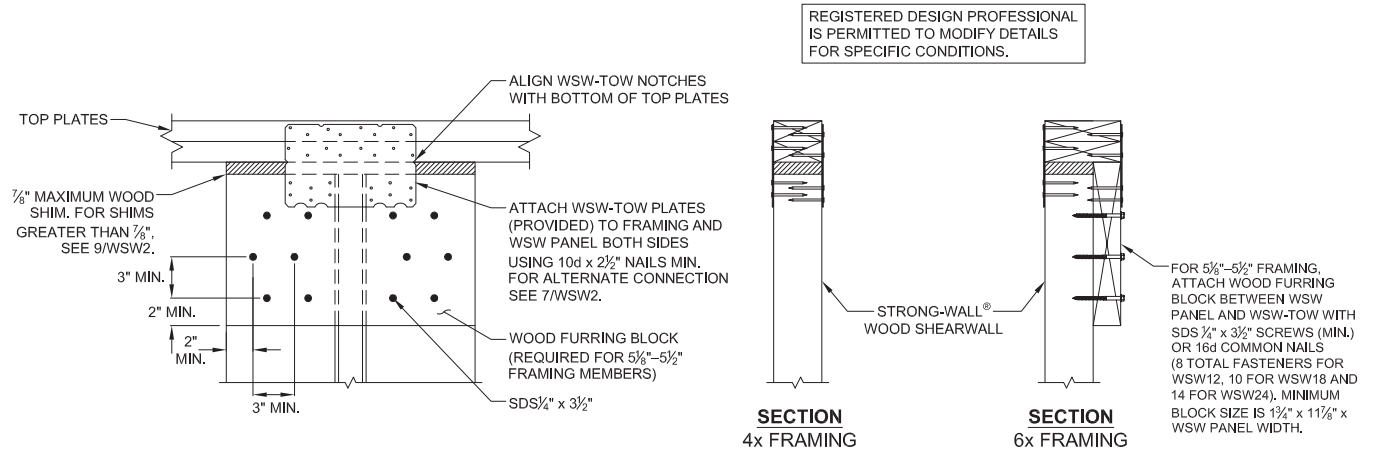

STANDARD TOP CONNECTION

6/WSW2

WSW-TOW ALTERNATE CONNECTION KIT		
MODEL NO.	FASTENER QUANTITY	
	SD #10 x 1 1/2"	SDS 1/4" x 6"
WSW-TOW12KT	20	2
WSW-TOW18KT	28	4
WSW-TOW24KT	40	8

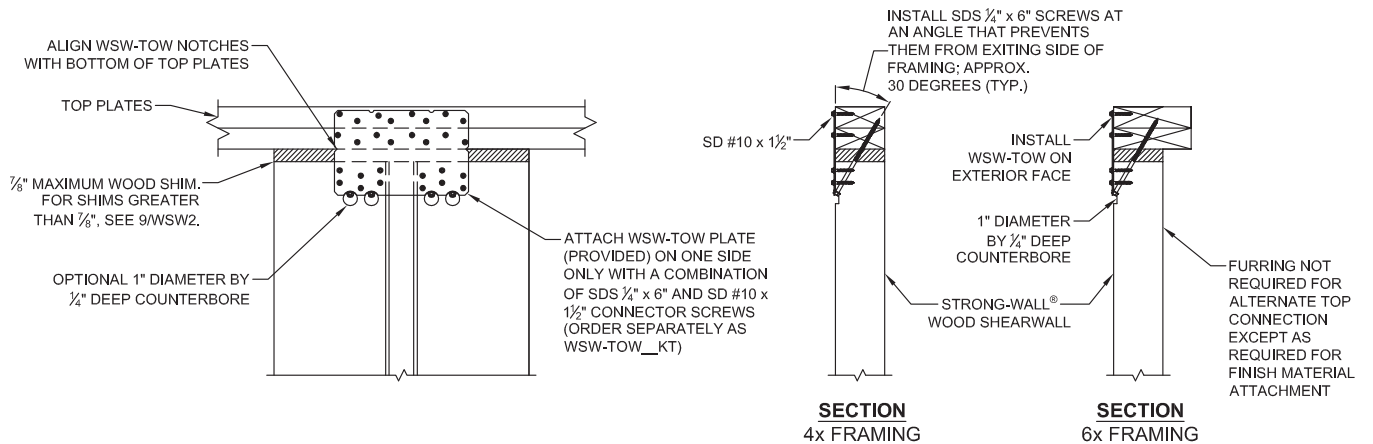

ALTERNATE TOP CONNECTION

7/WSW2

Installation Details

REGISTERED DESIGN PROFESSIONAL IS PERMITTED TO MODIFY DETAILS FOR SPECIFIC CONDITIONS.

INSTALL SDS 1/4" x 6" SCREWS (ORDER SEPARATELY). INSTALL IN 2 ROWS AS SHOWN AND COUNTERSINK AS REQUIRED.

QTY. OF SDS 1/4" x 6" SCREWS REQ'D.	
WSW12	4
WSW18	8
WSW24	12

EDGE DISTANCE FOR SCREWS		
SLOPE	A (IN.)	B (IN.)
0:12-4:12	2	3
5:12-8:12	1 1/2	4 1/2
9:12-12:12	1/2	5 1/2

1. MAINTAIN END DISTANCES TO PREVENT SCREWS FROM PENETRATING THROUGH THE OUTER EDGES.
2. INSTALL SCREWS PERPENDICULAR TO THE TOP PLATE.
3. EDGE DISTANCES ASSUME DOUBLE TOP PLATE.

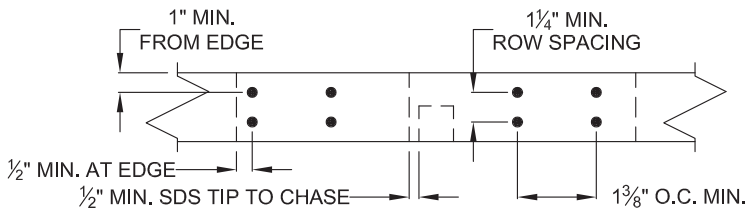
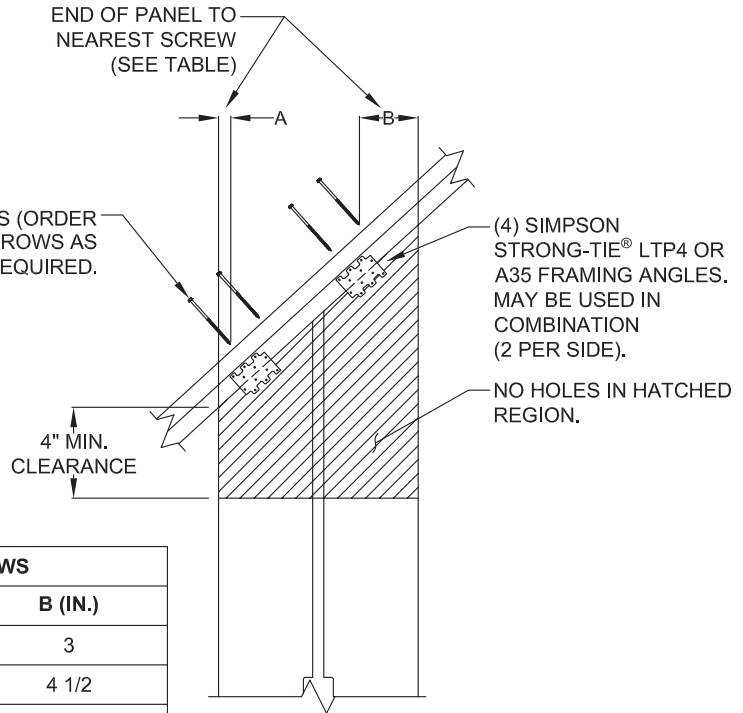

PLAN VIEW
SDS SCREW SPACING

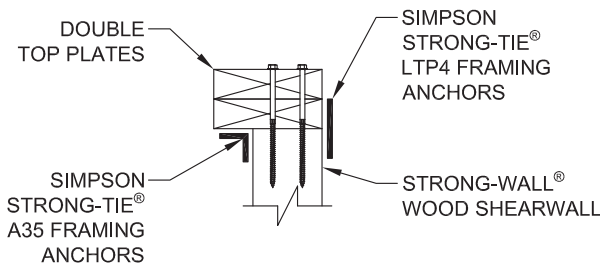
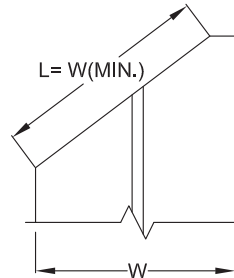

SECTION VIEW
2X6 OR WIDER FRAMING

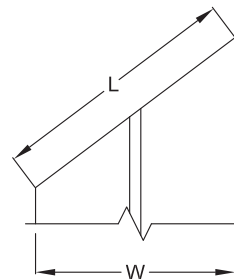

- INSTALLATION NOTES :**
1. ACTUAL CUT LENGTH (L) MUST BE GREATER THAN OR EQUAL TO PANEL WIDTH (W).
 2. THIS DETAIL APPLICABLE FOR SLOPES UP TO 12:12.
 3. PANELS TALLER THAN 12' MUST BE DESIGNED FOR THE APPLICATION.

Installation Details

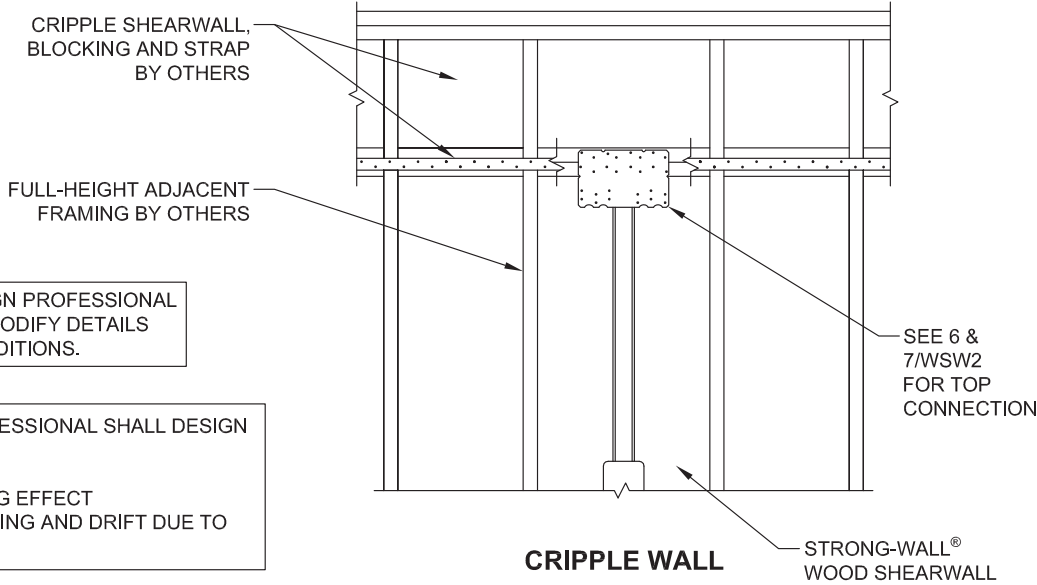
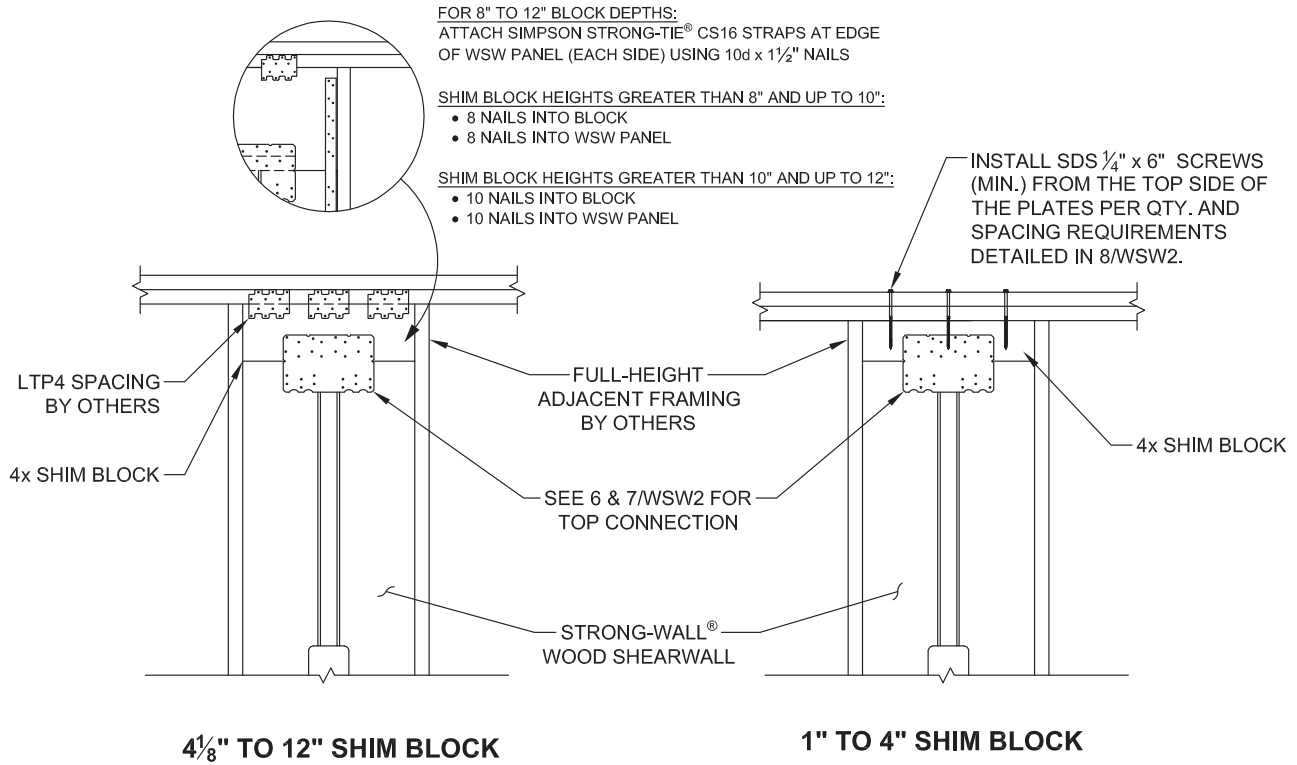

REGISTERED DESIGN PROFESSIONAL IS PERMITTED TO MODIFY DETAILS FOR SPECIFIC CONDITIONS.

REGISTERED DESIGN PROFESSIONAL SHALL DESIGN AND DETAIL FOR :

1. SHEAR TRANSFER
2. OUT-OF-PLANE LOADING EFFECT
3. INCREASED OVERTURNING AND DRIFT DUE TO ADDITIONAL HEIGHT

© 2021 Simpson Strong-Tie Company Inc. C-L-WSWCAN21

Installation Details

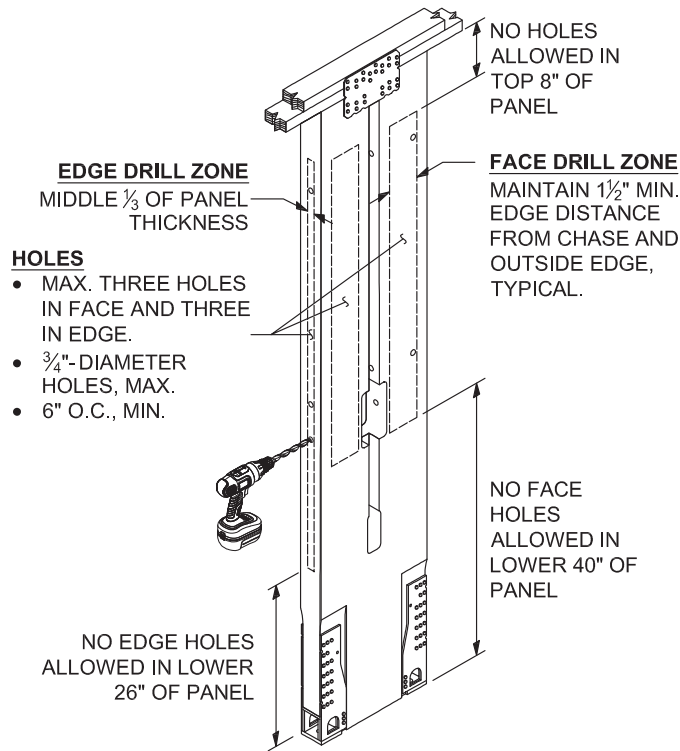

ALLOWABLE SMALL HOLES
FACE AND EDGE DRILL ZONES

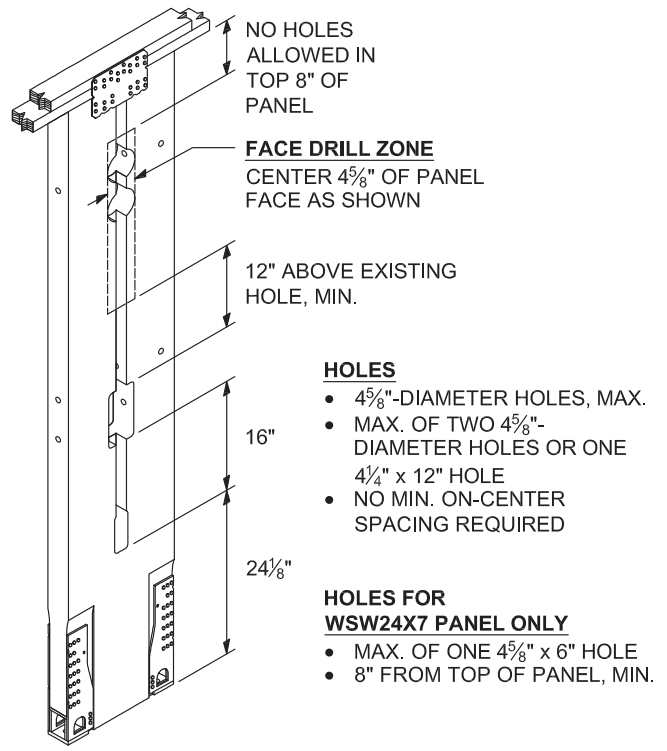

ALLOWABLE LARGE HOLES
IN ADDITION TO ALLOWABLE SMALL HOLES

Installation Details

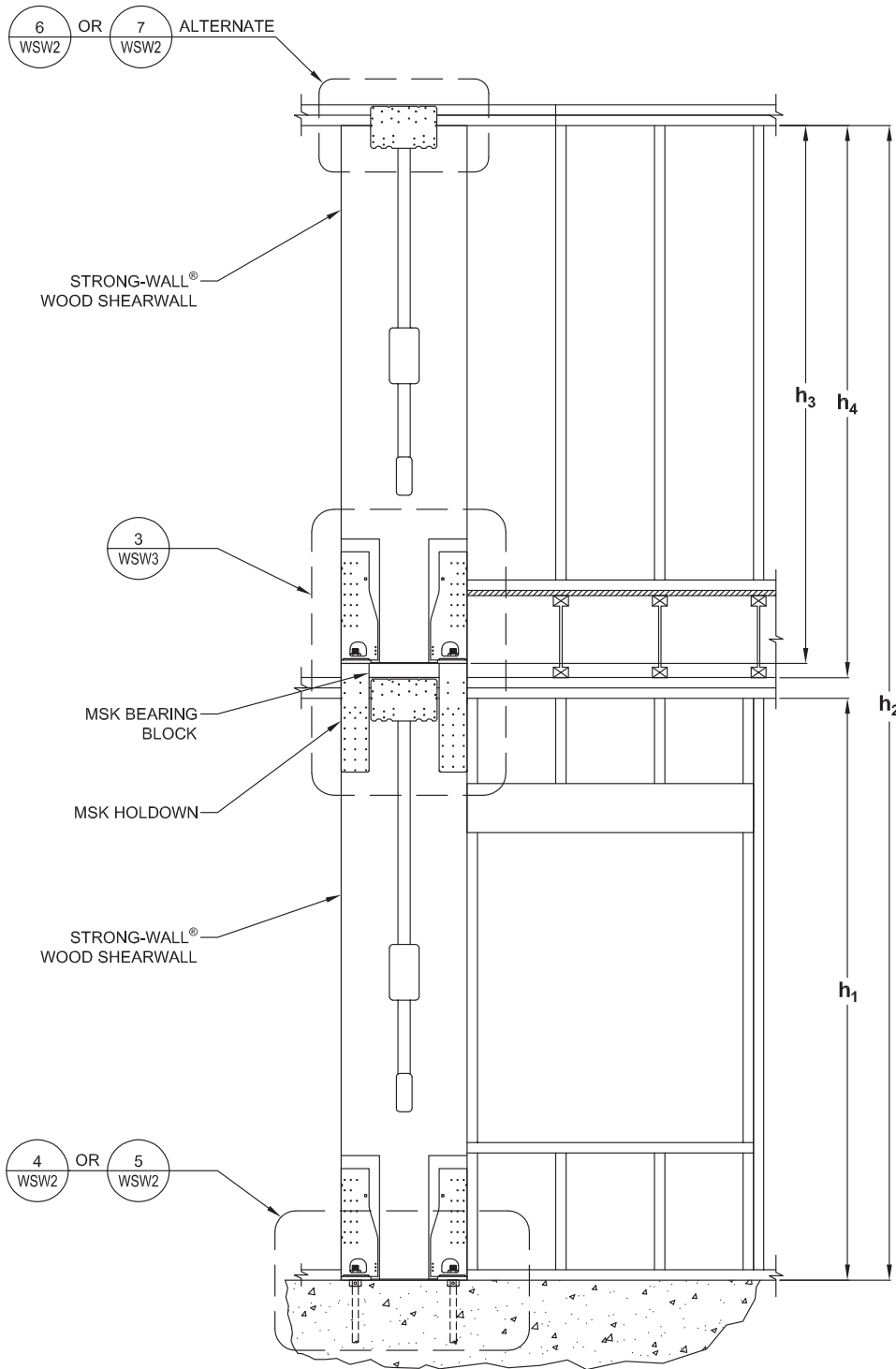

NOTES:

1. 1ST STOREY WSW MUST BE THE SAME WIDTH AS THE 2ND STOREY WSW.
2. JOIST AND SHEATHING MAY BE ATTACHED TO WSW WITH JOIST HANGER AND LEDGER. LOAD TRANSFER IS THE RESPONSIBILITY OF THE DESIGN PROFESSIONAL OF RECORD.
3. WSW MULTI-STOREY KIT (MSK) INCLUDES MSK BEARING BLOCK AND MSK HOLDDOWN.

LEGEND:

- h_1 = 1ST STOREY WSW HEIGHT; TOP OF CONCRETE TO UNDERSIDE OF 1ST STOREY TOP PLATES (IN.)
- h_2 = TOTAL ASSEMBLY HEIGHT; TOP OF CONCRETE TO UNDERSIDE OF 2ND STOREY TOP PLATES (IN.)
- $h_3 = h_4 - 2"$ = 2ND STOREY WSW HEIGHT; TOP OF BEARING BLOCK TO BOTTOM OF 2ND STOREY TOP PLATES (IN.)
- h_4 = TOP OF 1ST STOREY TOP PLATES TO UNDERSIDE OF 2ND STOREY TOP PLATES (IN.)

REGISTERED DESIGN PROFESSIONAL IS PERMITTED TO MODIFY DETAILS FOR SPECIFIC CONDITIONS.

© 2021 Simpson Strong-Tie Company Inc. C-L-WSWCAN21

Installation Details

FOR 2X6 AND WIDER WALL FRAMING, CUT SLOTS IN TOP PLATES TO ALLOW MSK HOLDDOWN TO PASS THROUGH. DO NOT NOTCH DOUBLE TOP PLATE.

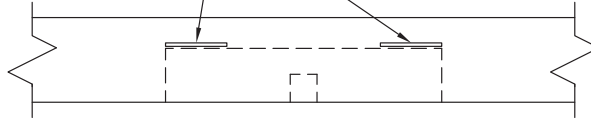

PLAN VIEW
6x FRAMING

REGISTERED DESIGN PROFESSIONAL IS PERMITTED TO MODIFY DETAILS FOR SPECIFIC CONDITIONS.

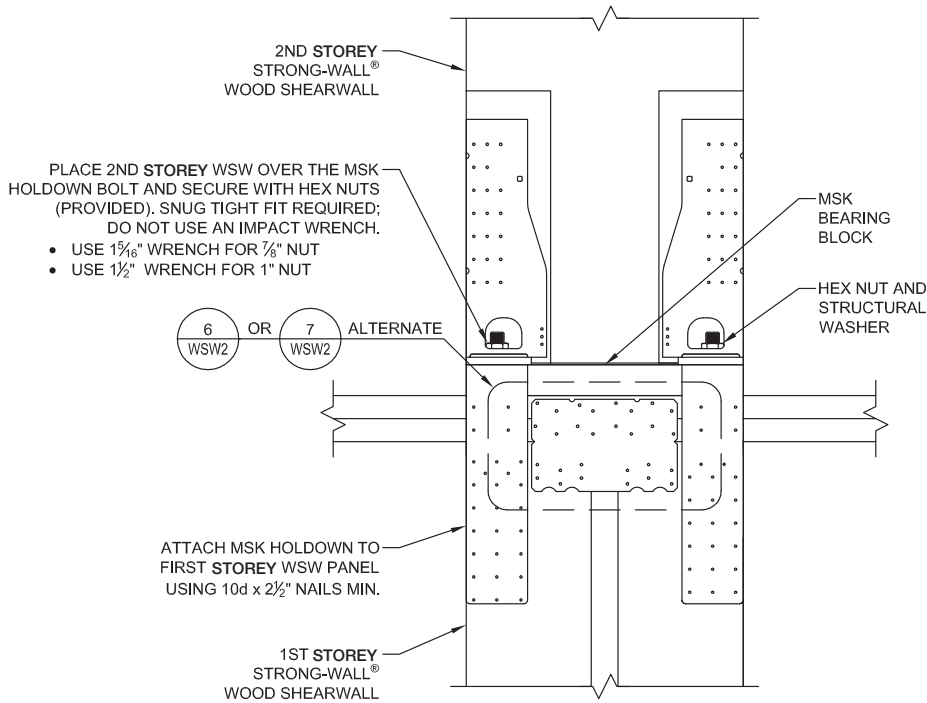

SECTION
4x FRAMING:
SEE 6 & 7/WSW2
FOR CONNECTION
DETAILS

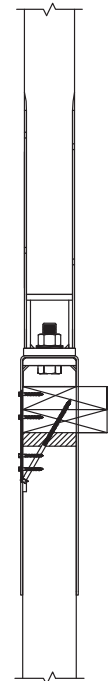

SECTION
6x FRAMING:
SEE 7/WSW2
FOR CONNECTION
DETAILS

Installation Details

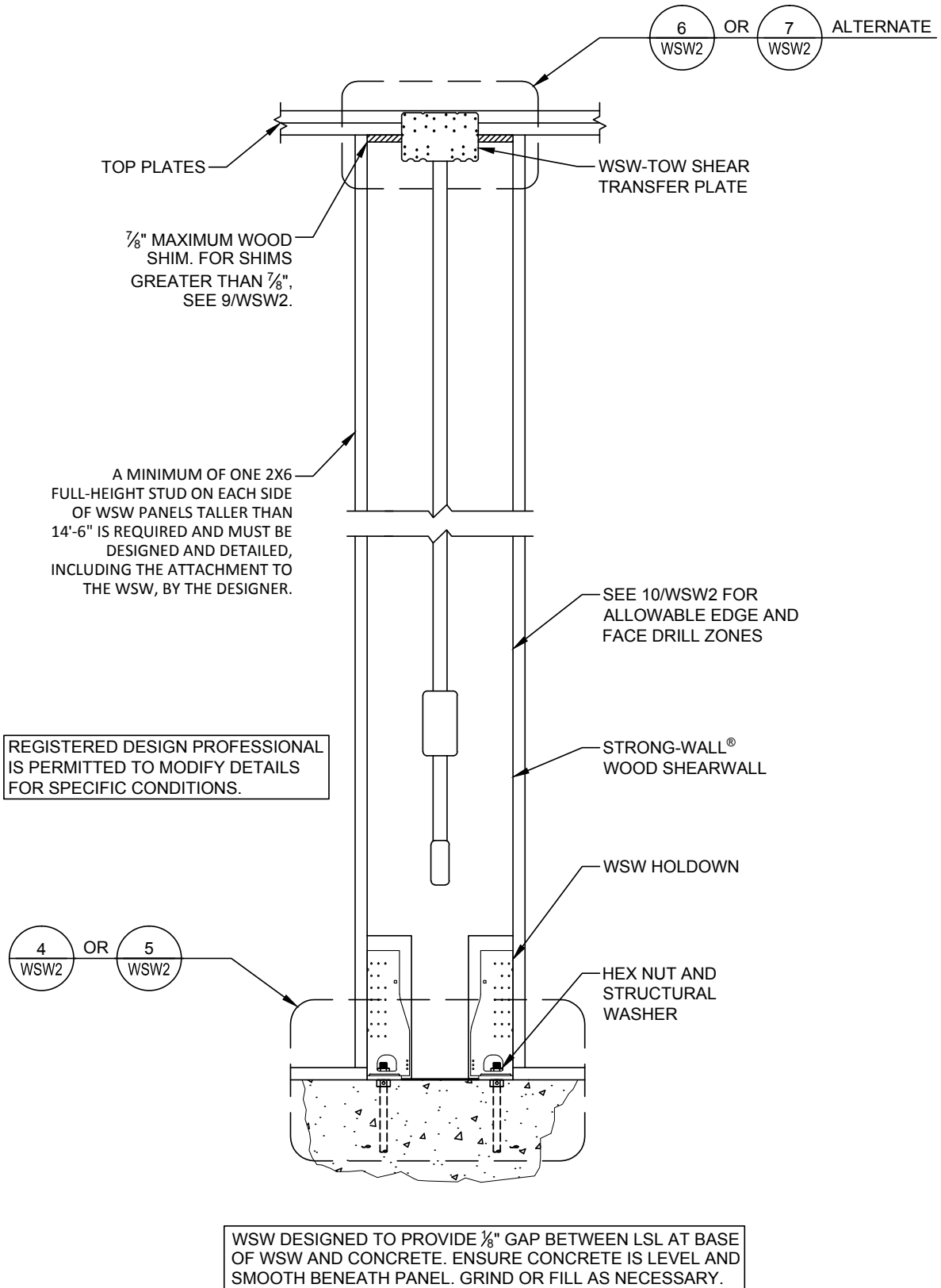

© 2021 Simpson Strong-Tie Company Inc. C-L-WSWCAN21

Installation Details

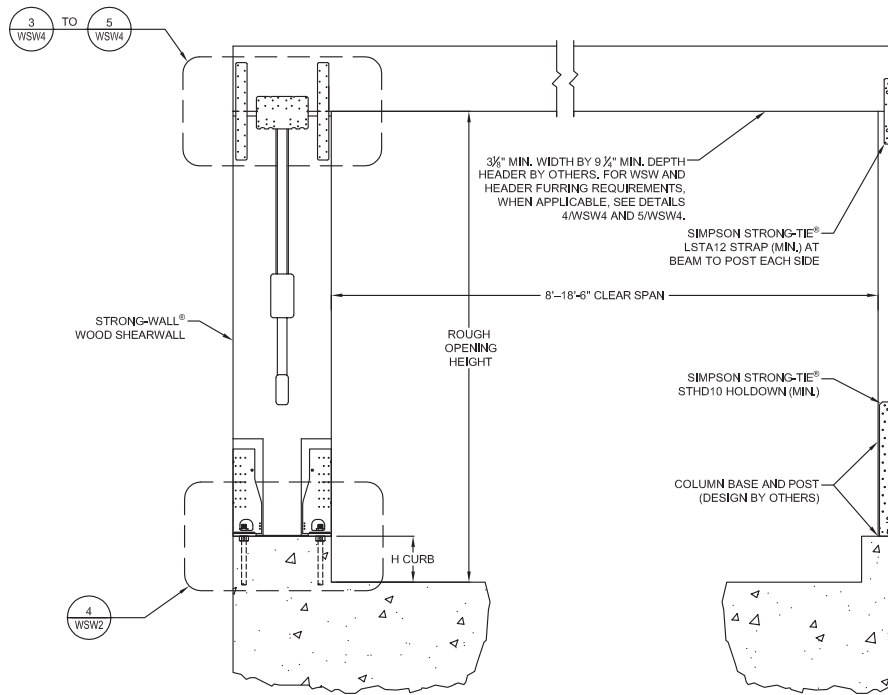

GARAGE HEADER ROUGH OPENING HEIGHT		
MODEL NO.	H CURB	ROUGH OPENING HEIGHT
WSW12x7 WSW18x7 WSW24x7	5 1/2"	6'-11 1/2"
	6"	7'-0"
	0"	7'-1 1/2"
WSW12x8 WSW18x8 WSW24x8	5 1/2"	8'-2 3/4"
	6"	8'-3 1/4"

1. IF REQUIRED ROUGH OPENING HEIGHT EXCEEDS TABLE VALUE, SPECIFY NEXT TALLER PANEL AND TRIM AS NECESSARY, THE STRONG-WALL® WOOD SHEARWALL MAY BE TRIMMED TO A MINIMUM HEIGHT OF 74 1/2".
2. FURRING DOWN GARAGE HEADER MAY BE REQUIRED FOR CORRECT ROUGH OPENING HEIGHT.

REGISTERED DESIGN PROFESSIONAL IS PERMITTED TO MODIFY DETAILS FOR SPECIFIC CONDITIONS.

WSW DESIGNED TO PROVIDE 1/8" GAP BETWEEN LSL AT BASE OF WSW AND CONCRETE. ENSURE CONCRETE IS LEVEL AND SMOOTH BENEATH PANEL, GRIND OR FILL AS NECESSARY.

STRONG-WALL® WOOD SHEARWALL SINGLE PORTAL ASSEMBLY

1/WSW4

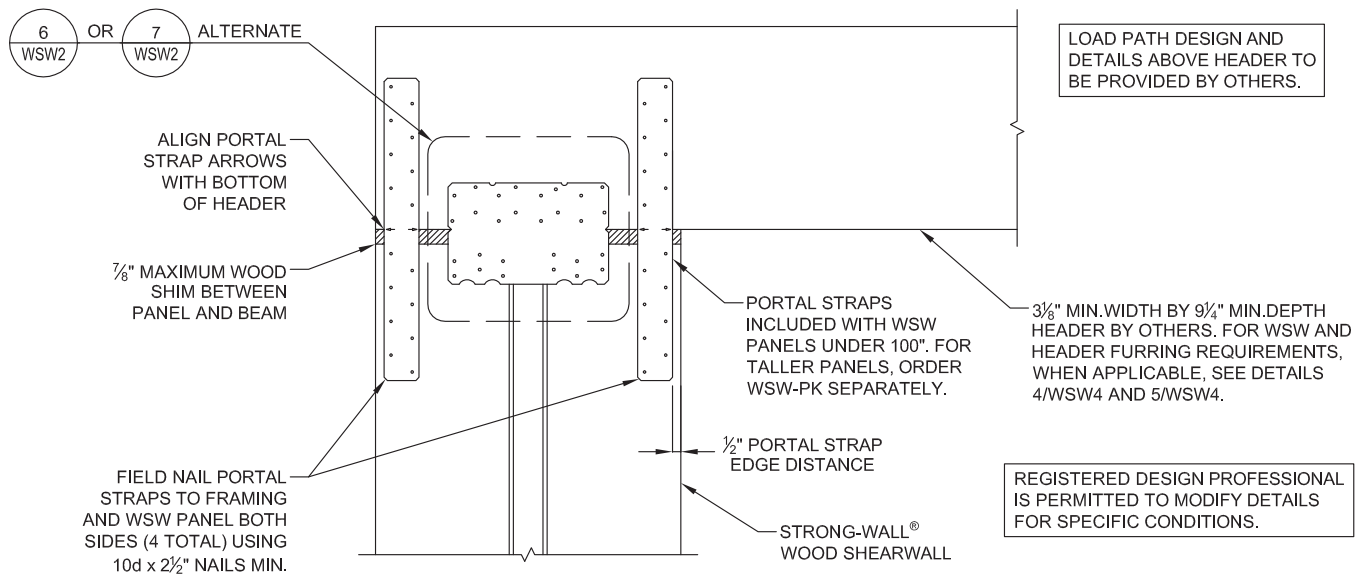

LOAD PATH DESIGN AND DETAILS ABOVE HEADER TO BE PROVIDED BY OTHERS.

REGISTERED DESIGN PROFESSIONAL IS PERMITTED TO MODIFY DETAILS FOR SPECIFIC CONDITIONS.

PORTAL TOP CONNECTION

3/WSW4

Installation Details

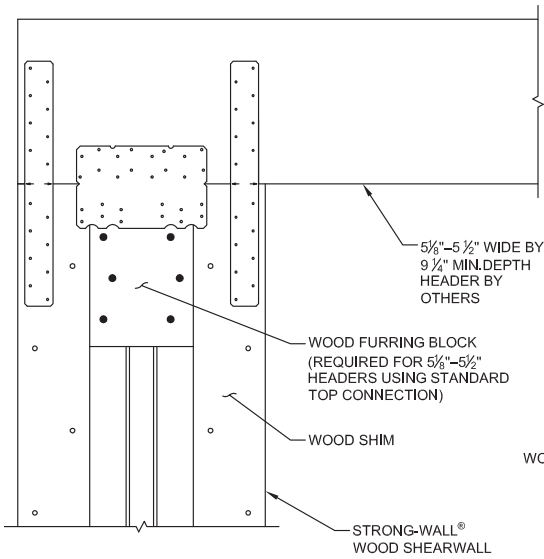

REGISTERED DESIGN PROFESSIONAL IS PERMITTED TO MODIFY DETAILS FOR SPECIFIC CONDITIONS.

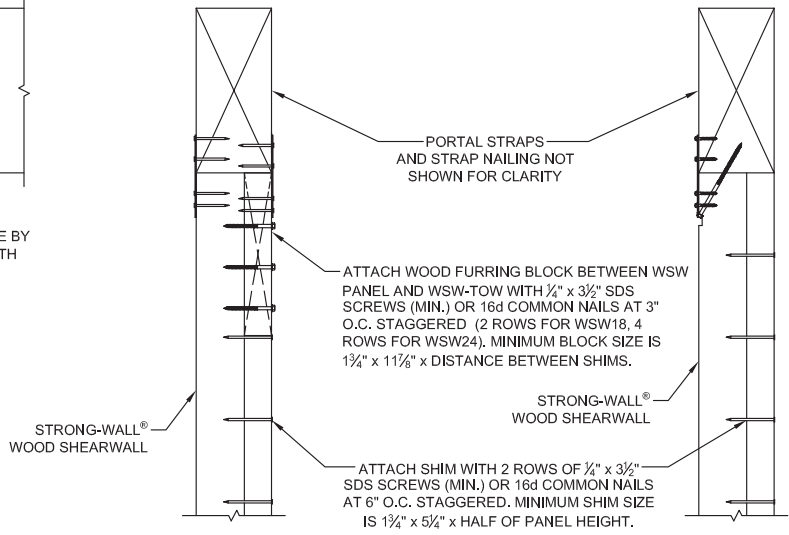

SECTION STANDARD
TOP CONNECTION
(FURRING BLOCK NOT REQUIRED FOR WSW12)

SECTION ALTERNATE
TOP CONNECTION
(BLOCK NOT REQUIRED)

FURRING FOR 5 1/8" TO 5 1/2" HEADER

4/WSW4

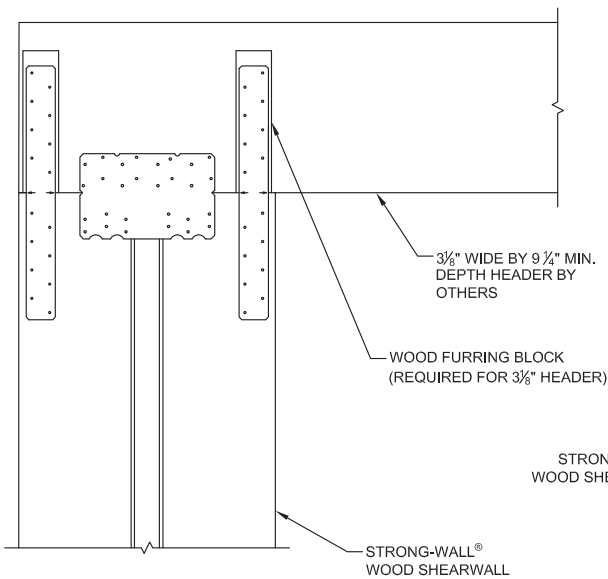

REGISTERED DESIGN PROFESSIONAL IS PERMITTED TO MODIFY DETAILS FOR SPECIFIC CONDITIONS.

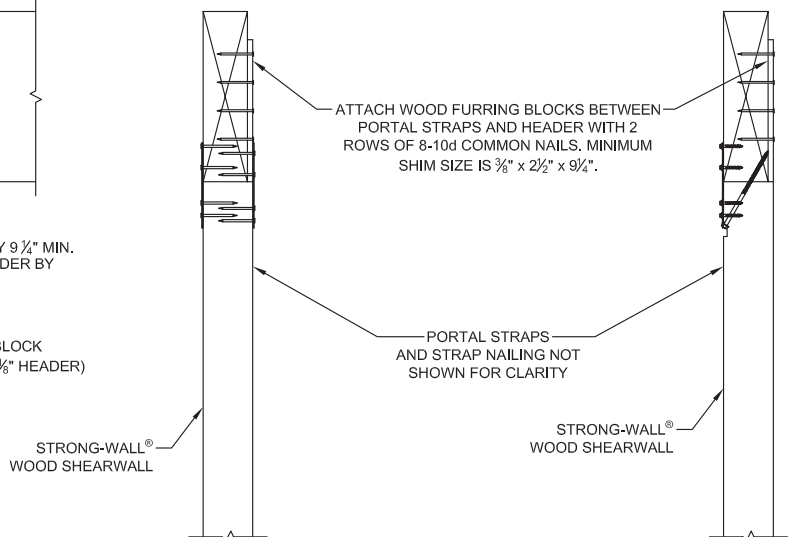

SECTION STANDARD
TOP CONNECTION

SECTION ALTERNATE
TOP CONNECTION

FURRING FOR 3 1/8" HEADER

5/WSW4



Every day we work hard to earn your business, blending the talents of our people with the quality of our products and services to exceed your expectations. This is our pledge to you.

Home Office

5956 W. Las Positas Boulevard
Pleasanton, CA 94588
Tel: (925) 560-9000
Fax: (925) 847-1603

Southeast USA

2151 South Airport Drive
McKinney, TX 75069
Tel: (972) 542-0326
Fax: (972) 542-5379

Northwest USA

5151 S. Airport Way
Stockton, CA 95206
Tel: (209) 234-7775
Fax: (209) 234-3868

Eastern Canada

5 Kenview Boulevard
Brampton, ON L6T 5G5
Tel: (905) 458-5538
Fax: (905) 458-7274

Southwest USA

12246 Holly Street
Riverside, CA 92509
Tel: (714) 871-8373
Fax: (951) 369-2889

Western Canada

811 – 19055 Airport Way
Pitt Meadows, BC V3Y 0G4
Tel: (604) 465-0296
Fax: (604) 465-0297

Northeast USA

2600 International Street
Columbus, OH 43228
Tel: (614) 876-8060
Fax: (614) 876-0636

Distribution Centers

Chandler, AZ; Inver Grove Heights, MN;
Enfield, CT; High Point, NC; Houston, TX;
Jacksonville, FL; Kansas City, KS;
Kent, WA; Jessup, MD

INTERNATIONAL FACILITIES

Please visit our website for address and contact information for our European facilities.

(800) 999-5099
strongtie.com