

Parasol Elite power EV charging service station solution with AI Micro-grid

Start your internet business *with BEST*

Ascidid has been running one of the biggest domain and web hosting sites in Korea since March 1998. More than 3,000,000 people have visited our website, www.ascidid.com, for domain registration and web hosting.



DEEP
BLUE
东方深蓝



Parasol Elite Power

Protect | People | Property | Environment

Micro-Grid

Micro-Grid : It refers to a small power generation and distribution system composed of distributed power sources, energy storage devices, energy conversion devices, loads, monitoring and protection devices, etc. A micro-grid is an autonomous system capable of self-control, protection, and management, and can operate either in conjunction with an external grid or in isolation.

Core technology:

The micro-grid energy management technology realizes the monitoring, control and optimal operation of the entire micro-grid. The main functions include micro-grid monitoring, load forecasting, renewable energy forecasting, optimal control decision-making, real-time energy scheduling, energy efficiency analysis, power quality analysis, etc.

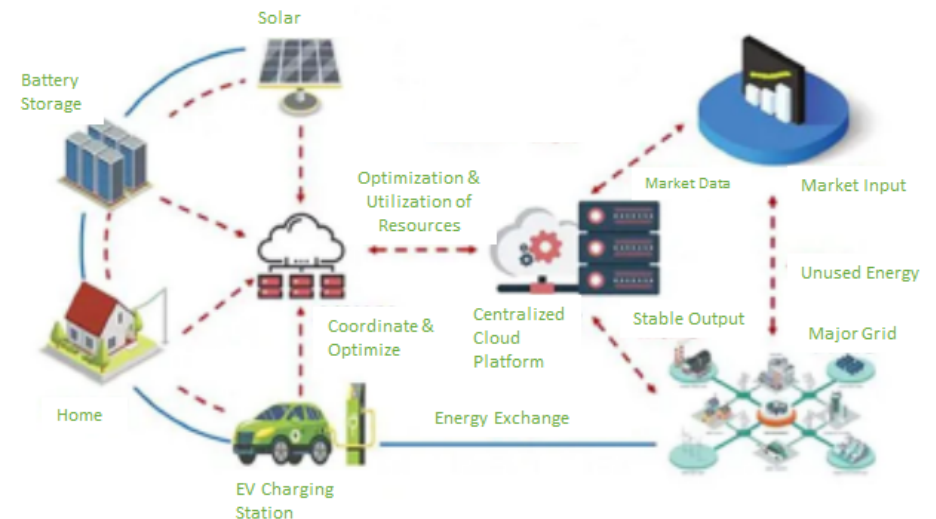

Platform Architecture

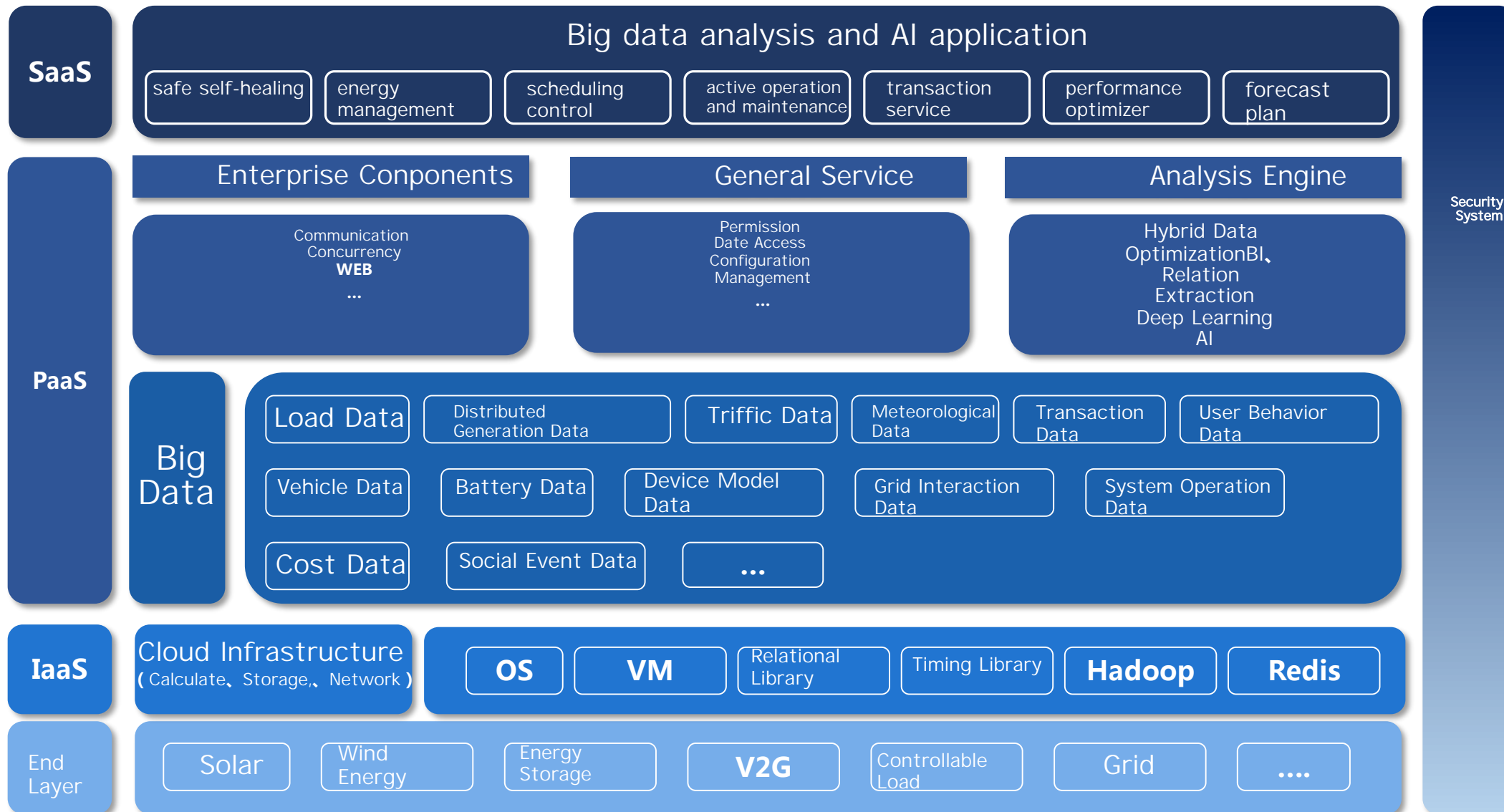

Micro-grid system integration of solar storage, charging and discharging

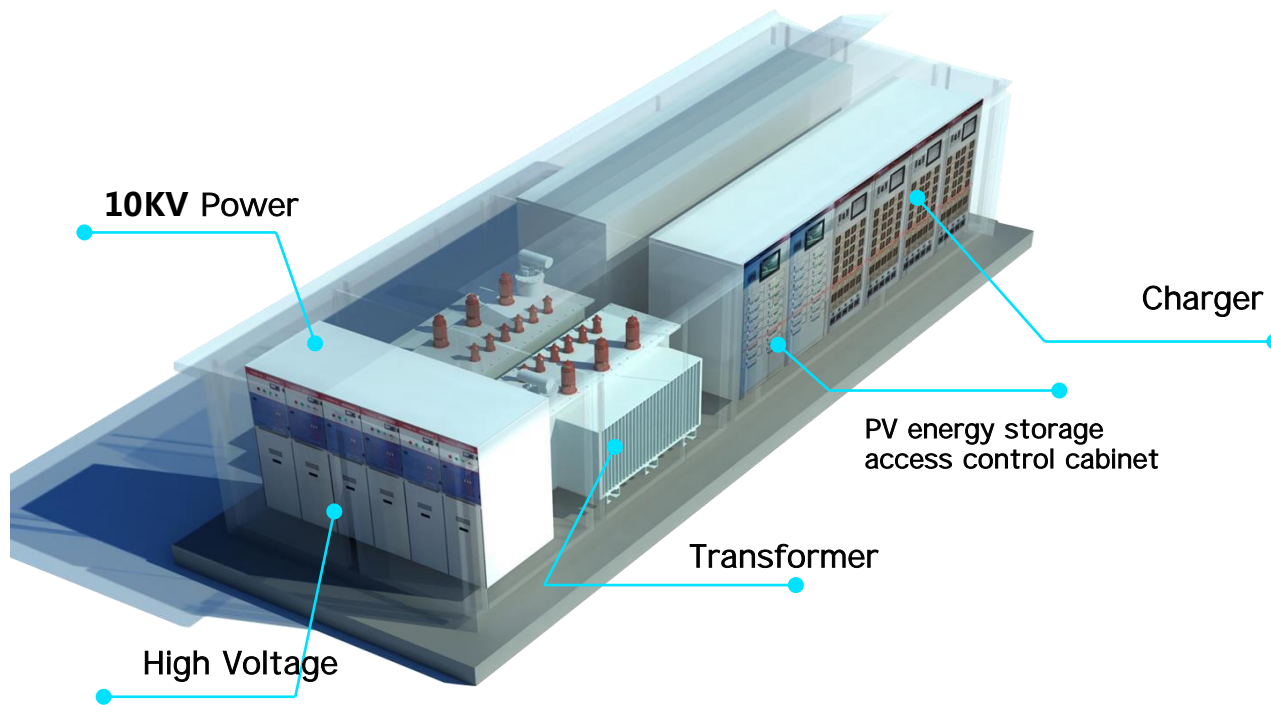

The new Parasol Elite Power energy micro-grid system is a micro-grid system formed by the flexible interconnection of multiple energy sources such as high-voltage power distribution, transformers, new power distribution, electric vehicle charging and discharging, load, energy storage, distributed photovoltaics, and four-quadrant conversion. It has functions such as energy routing, information interaction, load management, power quality regulation, off-grid operation, and micro-grid scheduling.

Solar storage charging AC grid-connected solution

The energy storage is transformed and connected to the EV through the PCS, the photovoltaic is transformed to the EV through the inverter, and the charger takes electricity from the EV.

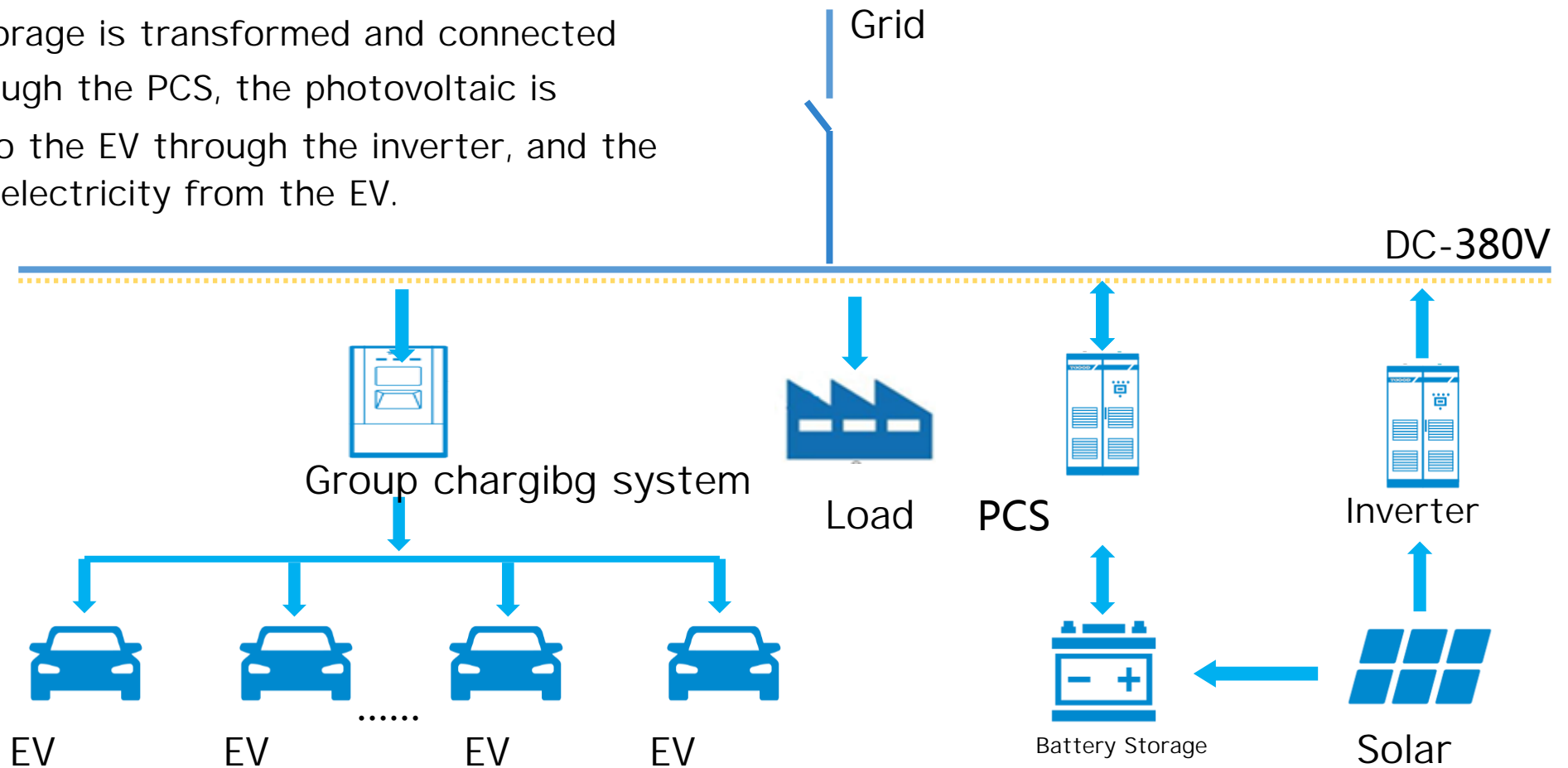

AC/DC Hybrid Micro-grid System

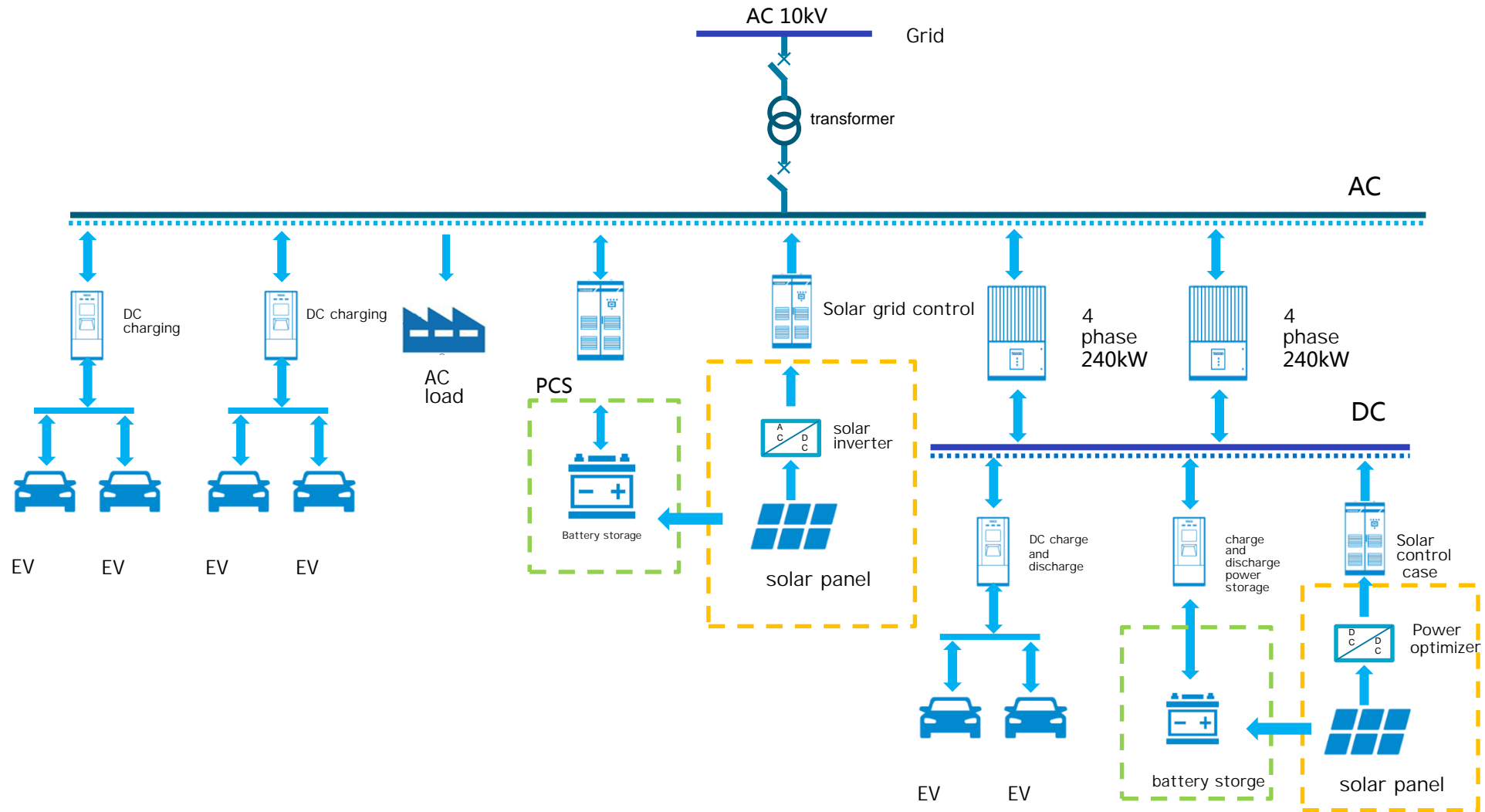

Functional module





Parasol Elite Power

Protect | People | Property | Environment



青岛东方深蓝信息科技股份有限公司
QINGDAO DEEP BLUE INFOTECH CO., LTD.