

ADA COMPLIANT LOCKER HANDLES

The following provides general information to identify which common locker handles can be ADA compliant. It is critical that any ADA locker handle and latching system be adjusted to operate with less than 5 pounds of effort. This may require periodic maintenance as all locker doors can get out of alignment over time.

Standard recessed handle with lifting trigger

The new industry standard handles can be opened with a closed fist and requires no tight grasping, pinching or twisting to comply with ADAAG #309.4 and CBC 11B-309.4.

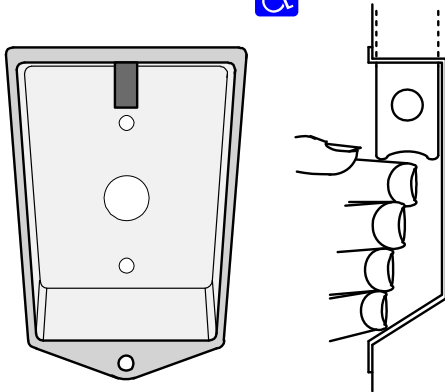

Single-point recessed handle

An optional handle from many manufacturers that has a lip at the top. This handle can be opened with a closed fist and requires no tight grasping, pinching or twisting to comply with ADAAG #309.4 and CBC 11B-309.4.

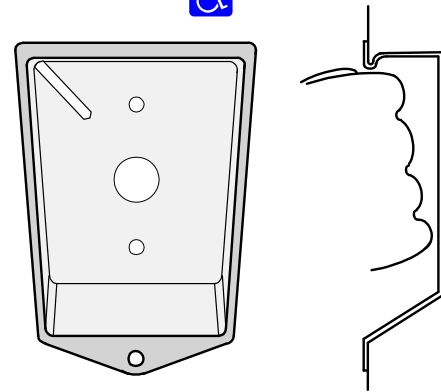

Exposed finger-pull handle

Often used on smaller openings called box lockers. This simple handle can be opened with a closed fist and requires no tight grasping, pinching or twisting to comply with ADAAG #309.4 and CBC 11B-309.4.

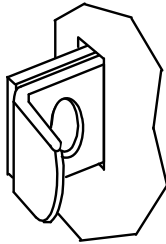

Exposed Handles

The old industry standard handles often require tight pinching to lift the handle.

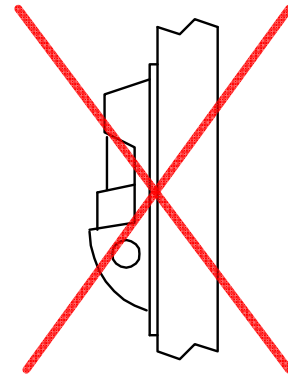

NOT ADA COMPLIANT

Specific Code requirements for LOCKER HANDLES

2004	2016
<u>ADAAG</u>	<u>CBC</u>
309.4	11B-309.4

Minimum Requirements

Controls shall be operable with one hand and not require tight grasping, pinching or twisting of the wrist. Force required for activation shall be no more than 5 lbs of effort.

IMPORTANT NOTE: Regardless of which handle is used, all ADA compliant openings must be adjusted to operate with less than 5 pounds of effort

Job: ADA Lockers
 Dwg: Handle Compliance
 Versn: 1 Date: 10/26/2017
 By: Chris Bruce

© 2017 Copyright includes layout, design, and other intellectual property. The drawings, specifications and other data herein provided shall not be copied, published or otherwise further disseminated without prior written permission of InnerSpace Engineering Corporation.

INNER SPACE
ENGINEERING CORPORATION
 SPACE SAVING & PRODUCTIVITY SOLUTIONS
 WWW.INNERSPACEENGINEERING.COM
 3390-B De La Cruz Blvd. Santa Clara, CA 95054
 PHONE: 408.980.8020 FAX: 408.819.9468