



Compact HRE

18 SB (G.C. 41-291-01)

24 SB (G.C. 41-291-02)

30 SB (G.C. 41-291-03)

40 SB (G.C. 41-291-07)

Installation, service and user instructions

Please read these installation instructions carefully before installing and using the appliance. Keep these installation instructions with the appliance.

Always act in accordance with the instructions indicated.



Benchmark places responsibilities on both manufacturers and installers. The purpose is to ensure that customers are provided with the correct equipment for their needs, that it is installed, commissioned and serviced in accordance with the manufacturer's instructions by competent persons and that it meets the requirements of the appropriate Building Regulations. The Benchmark Checklist can be used to demonstrate compliance with Building Regulations and should be provided to the customer for future reference. Please read the Benchmark Checklist carefully, page 50, and complete all sections, as required by law, relevant to the appliance and installation. The details within the Checklist will be required in the event of any warranty work. On completion the Checklist must be left with the end user. The relevant sections of the Service Record, page 51, must be completed on each subsequent Service visit.

Installers are required to carry out installation, commissioning and servicing work in accordance with the Benchmark Code of Practice which is available from the Heating and Hotwater Industry Council who manage and promote the scheme. Visit www.centralheating.co.uk for more information.

CONTENT

| | | |
|----------|--|-----------|
| 1 | Preface | 4 |
| 1.1 | Regulation..... | 4 |
| 1.2 | Warnings..... | 4 |
| 1.3 | Manual handling..... | 4 |
| 1.4 | Warnings on the box..... | 4 |
| 1.5 | Pictograms..... | 4 |
| 1.6 | Abbreviations and descriptions used..... | 5 |
| 1.7 | This manual..... | 5 |
| 1.8 | Service and technical support..... | 5 |
| 1.9 | Product identification..... | 5 |
| 2 | Safety regulations | 6 |
| 2.1 | General..... | 6 |
| 2.2 | The Installation..... | 6 |
| 2.3 | Approvals..... | 7 |
| 2.4 | Technical data..... | 8 |
| 2.5 | Product FICHe according to CELEX-32013R0811, ANNEX IV..... | 9 |
| 2.6 | Components..... | 10 |
| 3 | General boiler information | 11 |
| 3.1 | General..... | 11 |
| 3.2 | Boiler controller..... | 11 |
| 3.3 | Parameter list..... | 11 |
| 3.4 | Heat transfer..... | 11 |
| 3.5 | Central heating system/automatic by-pass..... | 11 |
| 3.6 | Room temperature control..... | 11 |
| 3.7 | Integrated clock..... | 11 |
| 4 | Operation | 12 |
| 4.1 | General..... | 12 |
| 4.2 | Central heating mode..... | 12 |
| 4.3 | Operating modes..... | 12 |
| 4.4 | Clock function (heat only)..... | 13 |
| 4.5 | PC Interface..... | 13 |
| 4.6 | Test programs..... | 14 |
| 4.7 | Frost protection..... | 14 |
| 5 | Installer important points | 15 |
| 6 | Accessories | 16 |
| 7 | Installation | 18 |
| 7.1 | Overall dimensions..... | 18 |
| 7.2 | Installation location..... | 19 |
| 7.3 | Assembly..... | 20 |
| 7.4 | Installing the appliance..... | 21 |
| 8 | Connection | 22 |
| 8.1 | Connecting CH installation..... | 22 |
| 8.2 | Electrical connection..... | 23 |
| 8.3 | Condensate disposal..... | 25 |
| 8.4 | Flue System..... | 26 |

| | | |
|-----------|--|-----------|
| 9 | Commissioning the appliance | 29 |
| 9.1 | Filling and venting the appliance and the installation | 29 |
| 9.2 | Commissioning the appliance | 31 |
| 9.3 | Setting and adjusting the clock functions | 32 |
| 9.4 | Additional functions | 32 |
| 9.5 | Shutting down..... | 33 |
| 10 | Setting and adjustment | 34 |
| 10.1 | Directly via the operating panel | 34 |
| 10.2 | Setting via the service code | 35 |
| 10.3 | Parameters | 35 |
| 10.4 | Weather– compensation adjustment..... | 36 |
| 10.5 | Setting maximum CH power..... | 37 |
| 10.6 | Adjusting pump setting..... | 37 |
| 10.7 | Gas-Air ratio control | 38 |
| 10.8 | Checking the gas air ratio control..... | 39 |
| 10.9 | Conversion to different gas type..... | 43 |
| 11 | Faults | 44 |
| 11.1 | Fault codes | 44 |
| 11.2 | Other faults..... | 45 |
| 12 | Maintenance | 48 |
| 12.1 | Disassembly | 48 |
| 12.2 | Cleaning | 48 |
| 12.3 | Assembly..... | 49 |
| 12.4 | Combustion | 49 |
| 13 | Electrical diagram | 50 |
| 13.1 | Electrical diagram HRE SB | 50 |
| 13.2 | NTC resistances | 50 |
| 13.3 | Typical Y Plan connection | 51 |
| 13.4 | Typical S Plan connection..... | 51 |
| 14 | Short spares list | 52 |
| 15 | Warranty conditions | 53 |
| 16 | CE declaration | 53 |
| 17 | Gas boiler system commissioning checklist | 54 |
| 18 | Service record | 55 |

© 2015 Intergas Heating Ltd. All rights reserved.

The information provided applies to the standard version of the product. Intergas Heating Ltd cannot therefore be held liable for any loss or damage arising from product specifications deviating from the standard version. The available information has been compiled with all possible care, but Intergas Heating Ltd cannot be held liable for any errors in the information or for the consequences thereof.

Intergas Heating Ltd cannot be held liable for any loss or damage arising from work performed by third parties.

Subject to change.

1 PREFACE

1.1 Regulation

The Intergas boiler meets the requirements of Statutory Instrument 'The Boiler (Efficiency) Regulations' and is deemed to meet the requirements of:

- Gas Appliance Directive 90/396/EEC
- Boiler Efficiency Directive 92/42/EEC
- Low Voltage Directive 2006/95/EC and
- Electromagnetic Compatibility Directive 2004/108/EC

Intergas declares that the materials used in the manufacturing of this appliance are non-hazardous and that no substances harmful to health are contained within the appliance.

1.2 Warnings

Intergas accepts no responsibility for the unsatisfactory performance of the appliance or flue arising from the failure to comply with the installation and user instructions. Incorrect installation could invalidate your guarantee and may lead to prosecution.

If the appliance is re-sold or installation transferred the appliance must be re-registered with Intergas in order to maintain the warranty.

The boiler must be installed in accordance with these instructions and the regulations currently in force. Read these instructions carefully before installing or using the appliance.

1.3 Manual handling

When moving the boiler always keep your back straight, bend your knees, don't twist, move your feet. Avoid bending forwards or sideways and keep the load as close to your body as possible. Where possible transport the boiler using a suitable trolley, sack truck or get some assistance. Grip the boiler firmly and before lifting establish where the weight is concentrated to determine the centre of gravity, repositioning yourself if necessary.

1.4 Warnings on the box



This is a fragile piece of equipment: Please provide a dry storage for the appliance.



This is a fragile piece of equipment: Please be very careful not to drop.



Store the appliance upright as indicated on the box.



No more than three boxes should be stacked on top of each other.

1.5 Pictograms

The following pictograms are used in this manual:



CAUTION

Procedures which – if they are not performed with the necessary caution – can result in damage to the product, the surrounding area or the environment, or in physical injury.



WARNING HIGH VOLTAGE

Risk of electrical shock.



NOTE

Important information regarding the correct usage or installation of the appliance.



FROST PROTECTION

Procedures which must be followed to prevent frost damage.

1.6 Abbreviations and descriptions used

| Description | Referred to as |
|---|------------------|
| High efficiency | HE |
| Intergas Compact HRE SB wall mounted gas fired boiler | Appliance |
| Appliance plus pipe work for central heating | CH installation |
| Appliance plus pipe work for domestic hot water | DHW installation |

1.7 This manual

This manual will enable you to assemble, install and maintain the appliance safely. Follow the instructions carefully. In case of doubt contact the manufacturer. Keep these installation instructions with the appliance.

1.8 Service and technical support

For information about specific adjustments, installation, maintenance and repair work, please contact:

Intergas Heating Ltd
 Building 94, Bay 1 Vantage Point
 The Pensnett Estate
 Kingswinford
 West Midlands
 DY6 7FS
 Tel: 01527 888000
 Fax: 01384 279480
info@intergasheating.co.uk
www.intergasheating.co.uk

1.9 Product identification

You will find the appliance data on the data plate on the underside of the appliance.

- Model
- G.C. registration number
- Heat input (net) [kW]
- Heat output CH [kW]
- Appliance category
- Gas type
- Gas supply pressure [mbar]
- NOx class
- Appliance type
- Maximum CH pressure [bar]
- Electrical supply
- Protection
- PIN
- Serial number
- Production year

Compact HRE ** SB

No:
Anno:

Condensing boiler

| | |
|------------|-------------------------|
| Type | C13,C33,C43,C53,C63,C83 |
| NOx classe | 5 |
| PIN | 0063 BT 3576 |
| G.C. | 41-291-** |

| | | |
|---------------|---------------------|---------------|
| GB, IE | G20 - 20mbar | I12H3P |
|---------------|---------------------|---------------|

| | | | |
|---|---------|---------|-----|
|  | Qn (Hi) | ** - ** | kW |
| | Pn | ** - ** | kW |
| | PMS | 3 | bar |
| | Tmax | 90 | °C |



~230V-50Hz, 80W, IP44



CE
0063

Intergas Heating Ltd
 Building 94, Bay 1
 Vantage Point, The Pensnett, Kingswinford
 DY6 7FS, United Kingdom

Made in Holland

2 SAFETY REGULATIONS

The manufacturer Intergas Heating Ltd accepts no liability whatsoever for damage or injury caused by failure to adhere (strictly) to the safety regulations and instructions, or carelessness during installation of the Intergas Compact HRE SB High Efficiency wall mounted gas fired boiler and any associated accessories.

2.1 General

It is law that all gas appliances are installed by a Gas Safe registered competent engineer and in accordance with the following recommendations:

- Current Gas Safety (Installation and Use) Regulations
- All current building regulations
- Building Standards (Scotland) Consolidated
- This appliance must be installed in accordance with the Gas (Safety and Use) Regulations, current Building Regulations, Building Standards (Scotland), I.S.813 Installation of Gas Appliances (Ireland), IEE Wiring Regulations (BS 7671), Health and Safety Document No. 635 (Electricity at Work Regulations) and Local Water Authority Bye Laws
- UK Water Regulations and Bye Laws
- Health & Safety



2.2 The Installation

The installation must comply with the following British Standards codes of practice:

- BS 5440: Flues and Ventilation for gas appliances of rated input not exceeding 70kW (Part 1 Flues)
- BS 5440: Flues and Ventilation for gas appliances of rated input not exceeding 70kW (Part 2 Air Supply)
- BS 5546: 2000 Installation of gas hot water supplies for domestic purposes.
- BS 5549: 1990 Forced circulation hot water systems
- BS 6700: 1997 Design, Installation, testing and maintenance of services supplying hot water
- BS 6798: 2000 Specification for installation of gas fired hot water boilers of rated input not exceeding 70kW
- BS 6891: 1998 Installation of low pressure gas pipe-work installations up to 35mm (RI)
- BS 7593: 1992 Code of practice for treatment of water in heating systems
- BS 7671: 2001 Requirements for electrical installations, IEE Wiring regulations



Reference should also be made to:

- Guide to condensing boiler installation assessment procedures for dwellings
- The institute of Gas Engineers document IGE/UP/7 for timber frame dwellings

2.3 Approvals

Natural Gas

Intergas Compact HRE SB Pre-mix Condensing System Boiler

British Gas Service Listing:

| | |
|-------------------|------------------|
| Compact HRE 40 SB | G.C.N. 41-291-07 |
| Compact HRE 30 SB | G.C.N. 41-291-03 |
| Compact HRE 24 SB | G.C.N. 41-291-02 |
| Compact HRE 18 SB | G.C.N. 41-291-01 |

Notified /Body

| | | |
|--------|------------|----------------------|
| Gastec | 0063PT3576 | Directive 90/396/EEC |
| | | Directive 92/42/EEC |

The Intergas Compact HRE SB range of central heating boilers are manufactured from high quality materials and designed for reliability and optimum performance.

Intergas is committed to the continual development of their appliances and reserves the right to make changes without notification to ensure their customers benefit from the latest advances in combustion technology and energy conservation.

2.4 Technical data

| | |
|---------------------|------------------------------|
| Appliance category | C13; C33; C43; C53; C83 |
| Gas supply pressure | 20 mbar -G20 ; 37 mbar – G31 |
| Gas Category | II2H3P |

| | | | | |
|-----------------------------------|--------------|--------------|--------------|--------------|
| Technical data Compact HRE | 18 SB | 24 SB | 30 SB | 40 SB |
|-----------------------------------|--------------|--------------|--------------|--------------|

| | | | | |
|--------------------|----------------|----------------|----------------|----------------|
| Gas Council number | G.C. 41-291-01 | G.C. 41-291-02 | G.C. 41-291-03 | G.C. 41-291-07 |
|--------------------|----------------|----------------|----------------|----------------|

| | | | | | |
|----------------------------------|-----|------------|------------|------------|------------|
| CH | | | | | |
| Nom. Input rating (lower value)* | kW | 5.6 – 18.7 | 7.1 – 23.7 | 7.6 – 27.0 | 7.8 – 42.5 |
| Rated power* | kW | 6.1 – 18.2 | 7.7 – 23.1 | 8.2 – 26.6 | 8.4 – 40.9 |
| Max. CH water pressure | bar | 2.5 | 2.5 | 2.5 | 2.5 |
| Max. CH water temperature | °C | 90 | 90 | 90 | 90 |

| | | | | | |
|------------------------------|------|-------------|-------------|-------------|-------------|
| Other data | | | | | |
| Gas consumption (G20) | m³/h | 0.58 – 2.29 | 0.75 – 2.91 | 0.79 – 3.39 | 0.80 – 4.41 |
| Gas consumption (G31) | m³/h | 0.22 – 0.87 | 0.28 – 1.11 | 0.30 – 1.29 | 0.31 – 1.68 |
| Appliance pressure loss (CH) | mWk | See § 10.5 | See § 10.5 | See § 10.5 | See § 10.5 |
| NOx class natural gas | | 5 | 5 | 5 | 5 |
| NOx class LPG | | 5 | 4 | 5 | 5 |

| | | | | | |
|-------------------------------|----|------|------|------|------|
| Electrical data | | | | | |
| Mains power | V | 230 | 230 | 230 | 230 |
| Safety class | IP | IP44 | IP44 | IP44 | IP44 |
| Power consumption : full load | W | 80 | 80 | 80 | 135 |
| Power consumption: standby | W | 2 | 2 | 2 | 2 |

| | | | | | |
|-------------------------------------|----|-----|-----|-----|-----|
| Boiler dimensions and weight | | | | | |
| Height | mm | 590 | 650 | 710 | 710 |
| Width | mm | 450 | 450 | 450 | 450 |
| Depth | mm | 240 | 240 | 240 | 240 |
| Weight | kg | 30 | 33 | 36 | 36 |

We have a policy for continual improvement and development, therefore we reserve the right to change specifications without prior notice.

2.5 Product FICHe according to CELEX-32013R0811, ANNEX iV

| | | | | | | |
|--|---------------|-------------|---|--------------|--------------|--------------|
| Supplier | | | Intergas Heating Ltd Building 94, Bay 1 Vantage Point The Pensnett Estate Kingswinford West Midlands DY6 7FS | | | |
| Type designation | Symbol | Unit | Compact HRE | | | |
| | | | 18 SB | 24 SB | 30 SB | 40 SB |
| Seasonal space heating energy efficiency class | - | - | A | A | A | A |
| Heat rated output (power) | P_{rated} | kW | 18 | 23 | 27 | 41 |
| Seasonal space heating energy efficiency | η_s | % | 93 | 93 | 93 | 92 |
| Annual energy consumption | Q_{HE} | GJ | 55 | 69 | 80 | 125 |
| Sound power level | L_{WA} | dB | 45 | 45 | 50 | 55 |



CAUTION

- Please read all instructions before fitting this appliance.
- This appliance is not intended for use of persons (including children) with diminished physical, sensory or mental ability, or lack of experience and knowledge, unless supervised by, or instruction about the use of the appliance by a person who is responsible for their safety.
- The appliance and installation should every year be inspected by an qualified installer and cleaned when necessary. See annual cleaning § 12
- The appliance can be cleaned with a damp cloth. Don't use aggressive or abrasive cleaning- or solvent products.

2.6 Components

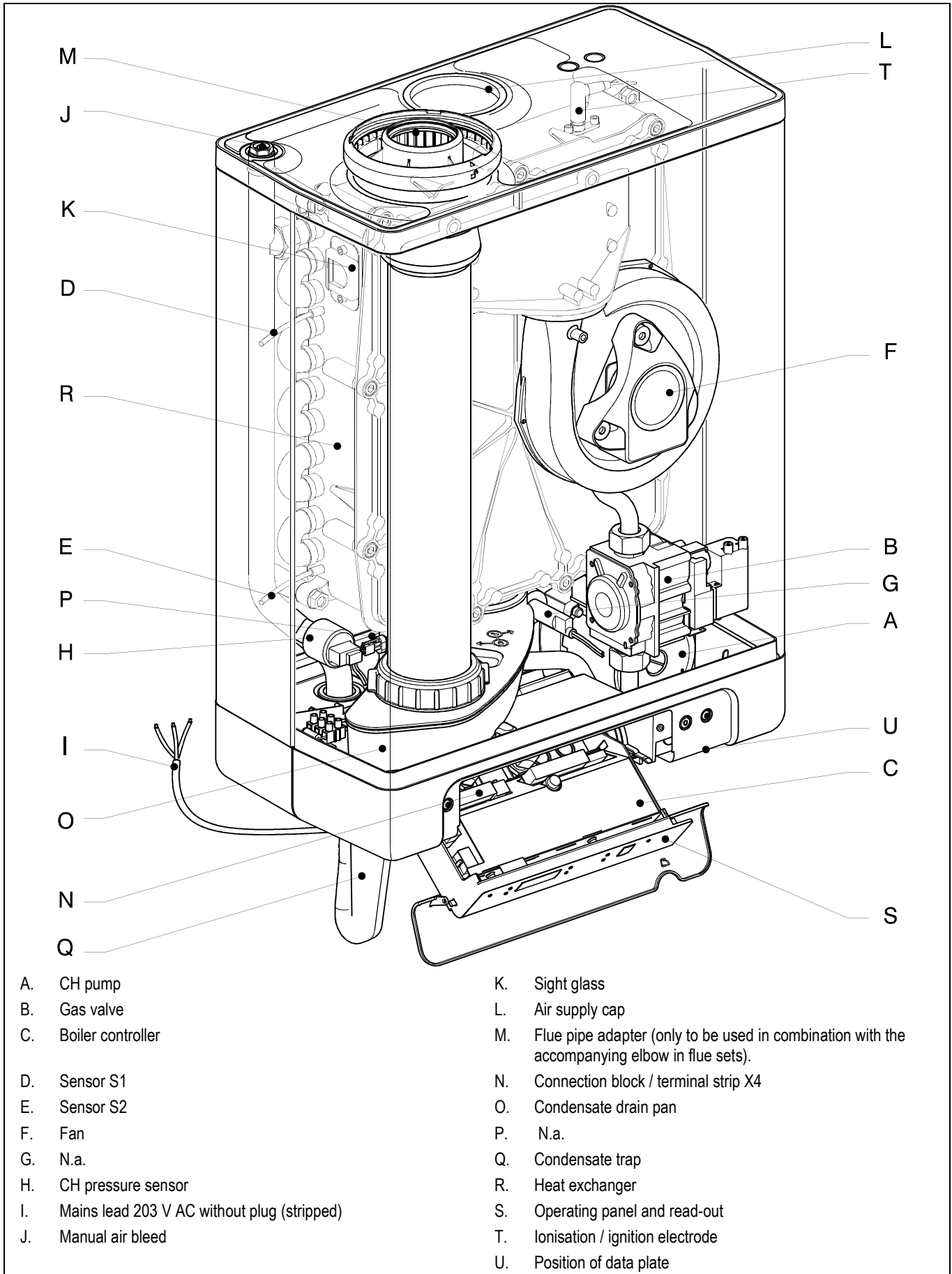

3 GENERAL BOILER INFORMATION

3.1 General

The Intergas Compact HRE SB wall mounted, gas fired boiler is a closed appliance. The appliance is intended to transfer heat to the water circuit in a CH system and when an indirectly heated domestic hot water (DHW) storage cylinder is installed, apply heat to the DHW installation.

The air supply and combustion gas flue connection is as standard prepared for a concentric 60/100 horizontal flue system. The appliance can be connected to a wall mounting jig and expansion vessel. The appliance can also be connected without the wall mounting jig using the robo kit.

The Intergas Compact HRE SB wall mounted gas fired boiler carries the CE rating and IP44 electrical protection.

The appliance is supplied as standard for natural gas (G20). For usage of propane gas (G31) the boiler can be modified by changing the gas injector. A gas conversion kit can be ordered at Intergas Heating Ltd.



NOTE

Modification of the boiler can only be done by a qualified competent person.

3.2 Boiler controller

An electronic control unit, consisting of a boiler controller and separate ignition module which is placed on the gas valve, provides direct burner ignition and flame supervision along with continuous modulation of the burner's gas supply.

3.3 Parameter list

All boiler adjustments are accessible through the parameter list in the software.

3.4 Heat transfer

Heat transfer to the boiler's heating circuit is obtained via a primary, gas to water heat exchanger within a hermetically sealed combustion chamber. A modulated speed fan blows the gas/air mixture into the combustion chamber and expels the products of combustion to outside air via an associated flue system.

3.5 Central heating system/automatic by-pass

An integral pump located in the boiler's hydraulic circuit circulates water through the heat exchanger to the central heating circuit. In the event of reduced or interrupted water circulation in the central heating circuit, an automatic system by-pass should be fitted as far away from the boiler as possible.

Note

It is no longer permissible to utilize a non-thermostatic controlled radiator as a by-pass.

3.6 Room temperature control

Room temperature can be controlled by the use of an external room thermostat and thermostatic radiator valves.

Note

Connection of the room thermostat is dependant on the operating voltage of the thermostat.

3.7 Integrated clock

The boiler incorporates an integrated clock, which allows the setting of central heating periods (See the User Instructions, 'Operation and display read-out' for details) and the boiler's control panel incorporates an LED display, which indicates the state of operation and fault defect codes.

Note

For S and Y plans set integral clock to C-ON and fit an external timer/programmer.



4 OPERATION

4.1 General

The Intergas Compact HRE SB wall mounted, gas fired system boiler is a modulating high efficiency boiler. This means that the power is adjusted in line with the desired heat requirement.

The appliance is equipped with an electronic boiler controller which, each time heat is requested from the heating supply, starts the fan, opens the gas valve, ignites the burner and continuously monitors and controls the flame, depending on the requested output.

4.2 Central heating mode

When a heating demand is requested (power is on, the timer and thermostat are calling for heat) the integral pump is energised and the boiler will fire automatically. The hot water is now circulated around the central heating system. When the end of the central heating demand is reached (the thermostat reaches temperature or the time clock reaches the end of its set period) the burner will shut down while the pump remains functioning during a preset period of time to dissipate any excess heat from within the boiler's heat-exchanger. After that the boiler will revert to stand-by, waiting to respond to the next heating demand.

4.3 Operating modes

A code on the service display of the operating panel indicates the appliance's operating mode.

Off

The appliance is out of operation but is supplied with electrical power. No response occurs to calls for DHW or CH. The appliance frost protection is active. This means that the pump operates and the exchanger is heated up if the temperature of the water present in it falls too far.

If the frost protection is actuated, code  is displayed (heating the exchanger).

In this operating mode the pressure in the CH installation (in Bar) can also be read on the temperature display.

Waiting mode

The LED at the  button is lit and possibly one of the LEDs for the DHW comfort function. The appliance is ready to respond to a request for CH or DHW.

Pump overrun of CH

After the end of CH operation the pump continues to run. The running time is factory set at the value in accordance with § 10.3. This setting can be changed.

In addition, the pump runs automatically for 10 seconds once every 24 hours in order to prevent seizing. This automatic switching on of the pump occurs at the time of the last call for heat. To change the time, the room thermostat setting should be increased briefly at the desired time.

Boiler shutdown when required temperature reached

The boiler controller can temporarily shut down the request for heat. The burner is then stopped. Shutdown occurs because the requested temperature has been reached. When the temperature has fallen sufficiently and the anti cycle time has passed the shutdown is cancelled.

Self-test

The connected sensors are checked regularly by the boiler controller. During the check the boiler controller does not perform any other tasks.

Ventilation

When the appliance is started the fan is first brought to starting speed. When the starting speed has been reached the burner is lit. Code  is also visible when post-ventilation is taking place after the burner has stopped.

Ignition

When the fan has reached the starting speed, the burner is ignited by means of electrical sparks. During ignition the code  is visible. If the burner does not ignite, a new ignition attempt occurs after approximately 15 seconds. If after 4 ignition attempts the burner is not yet burning, the boiler controller goes into fault mode (See § 11.1).

5 CH operation

An on/off thermostat, an OpenTherm thermostat, an external sensor or a combination of the latter can be connected to the boiler controller.

When a request for heat is received from a thermostat, the fan is started (code **3**), followed by ignition (code **4**) and CH operating mode (code **5**).

During CH operation the fan speed and hence the appliance power are controlled by the boiler controller so that the CH water temperature reaches the desired CH supply temperature.

If an on/off thermostat is connected, this is the CH supply temperature set on the display. In the case of an OpenTherm thermostat the desired CH supply temperature is determined by the thermostat. In the case of an external sensor the desired CH supply temperature is determined by the heating line programmed in the boiler controller. For the latter two, however, the maximum is the temperature set on the display.

During CH operation the requested CH supply temperature is indicated on the operating panel.

The CH supply temperature can be set between 30°C and 90°C.

4.4 Clock function (heat only)

The boiler is equipped with a digital clock and offers the possibility to program 4 points in time to switch from CH off or CH on.

During the “clock active” periods the boiler will respond on CH demands from the room thermostat. During the “clock inactive” periods the boiler will not respond on CH demands.

N.B. The clock function is only applicable when using the boilers as “heat only”. When using the boiler in combination with an external DHW tank, for example in an S or Y plan wired installation the clock must be set to C-on.

Additionally the following special modes can be chosen:

1. t-on (temporary on).
The boiler will respond to every CH demand from the room thermostat until the next switch moment.
2. c-on (continuous on).
The boiler will respond to every CH demand from the room thermostat without any time limit.
3. OFF.
The boiler will not respond to any CH demand from the room thermostat.



NOTE

For setting and adjusting the clock see § 9.3 Setting and adjusting the clock functions.



4.5 PC Interface

The boiler controller is equipped with an interface for a PC, which can be connected by means of a special cable and associated Intergas Diagnostic Software (IDS). This facility allows the behaviour of the boiler controller, the appliance and the heating installation to be monitored over a longer period.

4.6 Test programs

The boiler controller has a facility for placing the appliance in test mode. Activation of a test program will result in the appliance starting operation at a fixed fan speed, without the control functions being actuated. The safety functions do remain active. The test program is ended by pressing the **+** and **-** simultaneously or will end automatically after 10 minutes.

Test programs

| Program description | Button combinations | Display reading |
|---|---|------------------|
| Burner on at minimum power |  and - | "L" |
| Burner on with maximum CH power setting (See § 10.3, parameter 3) |  and + (1x) | "h" |
| Burner on with maximum DHW power (See § 10.3, parameter 4) |  and + (2x) | "H" |
| Switch off test program | + and - | Actual situation |

Addition readings :

During test mode the following data can be read :

- By pressing the **-** button continuously in the display the CH water pressure is shown.
- By pressing the **+** button continuously in the display the ionisation current is shown.

4.7 Frost protection



FROST PROTECTION

To prevent freezing the appliance is equipped with an internal frost protection. If the heat exchanger temperature falls too low, the burner switches on and the pump runs until the heat exchanger temperature is sufficient. When the appliance frost protection is activated the symbol code **7** is displayed (pre heating the heat exchanger).

If the installation (or a part of it) is in danger of freezing, an (external) frost thermostat must be fitted to the return line at the coldest location. This must be connected in accordance with the wiring diagram (See § 8.3).



NOTE

If the appliance is out of operation (**-** on the service display) the appliance's internal frost protection is still active. However, there will be no response to a heating demand from an (external) frost thermostat.







5 INSTALLER IMPORTANT POINTS



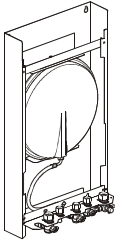
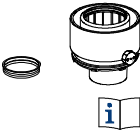

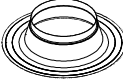

Please read all instructions before fitting this appliance

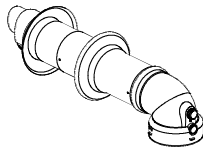
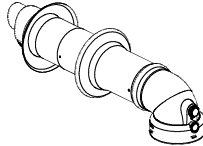
- The installer shall instruct the user on the operation of the boiler, safety devices contained within the boiler and on the location of the filling loop and how to re-pressurise the system if the water pressure falls.
- The installer should then hand over the instructions indicating the included Benchmark Commissioning Checklist that has been completed.
- It is required under Gas Safe Regulations for the installation to be notified to Building Control (Gas Safe Notification).
- Before proceeding to commission the boiler check the gas inlet pressure is 20mbar (NG) or 37mbar for Propane.
- Combustion analysis with a correctly calibrated and certificated analyser is essential for safe commissioning of the boiler.
- A pressure reducing valve set to 3.5 bar must be fitted if supply mains pressure is above 4 bar.
- A suitable scale reducer must be fitted if water hardness is above 200 ppm.
- The user should be instructed to keep the instructions in a safe place for servicing and future reference.
- It is important to keep the boiler clear of dust during the installation. In particular, do not allow debris to enter the flue connection at the top.
- Before fitting the boiler ensure that the pipe work that you are installing is connected to the appropriate connections on the boiler.
It is important to thoroughly flush the water circuits, after isolating the boiler, in order to remove any fluxes and debris from them. This should be done particularly where boilers are being fitted to existing radiator circuits (please refer to current Standard Codes of Practice).
- BS 7593:2006 for the details to clean DHW and Central heating system.
- This boiler has been factory set but adjustment may be required to the heating input in order to match the individual heating demand. This can be done by changing parameter 3 (= max. power CH) or parameter 4 (= max. power domestic water).
- Please do not use the pressure relief valve as a means of flushing the system.
- Remember that after hot water draw of a possible delay may occur before the heating system will fire up.
- All fluxes, residues and cleaner must be flushed from pipe-work and radiators prior to commissioning.
- External expansion vessels are best connected water side downwards to allow correct draining/cleaning of system and to prolong the life of the vessel diaphragm.
- Note: an anti-cycle delay time can be set up to a maximum of 15 minutes by adjusting parameter P as described in § 10.3.
- If you experience any problems please refer to the installation and commissioning guidelines within the boiler instruction manual. If necessary, please contact Intergas Heating Ltd (See § 1.8).

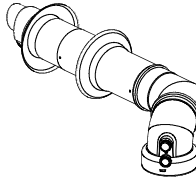
Remember it is a requirement to complete the Benchmark code of practice logbook before leaving the installation. You are also required to register the boiler through the Gas Safe registration scheme.

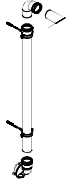
6 ACCESSORIES

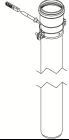
| Description | Article number | |
|---|----------------|---|
| Pipe cover set (incl. mounting material) | 093217 |  |
| Wall mounting jig + exp. vessel 8 litres HRE SB 30 & SB 40 | 093207 |  |
| Wall mounting jig + exp. vessel 8 litres HRE SB 24 | 093197 | |
| Wall mounting jig + exp. vessel 8 litres HRE SB 18 | 093187 | |
| Outside sensor | 203207 | |
| DHW storage cylinder sensor | 065117 | |
| Diverter valve 230 V | 092647 | |
| Concentric connection (boiler adapter) Ø60x100 <ul style="list-style-type: none"> Concentric flue adapter Sealing cap <i>Necessary when connecting to a higher positioned wall terminal</i> | 090547 |  |
| Sampling cap | 847000 | |
| Bend 45° | 084661 |  |
| Bend 90° | 084660 |  |
| Deflector kit | 081295 |  |
| Weather slate (steep roof) | 087910 |  |
| Weather slate (flat roof) | 087372 |  |
| Extension L=100 incl. wall bracket | 082975 |  |
| Horizontal straight wall terminal extended <i>Only to be used in combination with the base adapter on the boiler</i> | 082980 |  |
| Horizontal telescopic wall terminal <i>Only to be used in combination with the base adapter on the boiler</i> | 081297 |  |

| Description | Article number | |
|--|----------------|---|
| Horizontal telescopic offset wall terminal <i>Only to be used in combination with the base adapter on the boiler</i> | 081298 |  |
| Vertical roof terminal <i>(incl. boiler adapter 60/100)</i> | 082973 |  |
| Plume management kit | 081294 |  |
| Elbow 90° ((for Plume management kit) | 081284 |  |
| Elbow 60° (for Plume management kit) | 081285 |  |
| Extension L=100 incl. wall bracket (for Plume management kit) | 081286 |  |
| Robo kit 12 litres | 090000 |  |
| Robo kit 8 litres | 090100 |  |

7 INSTALLATION

7.1 Overall dimensions

Appliance inclusive wall mounting jig:

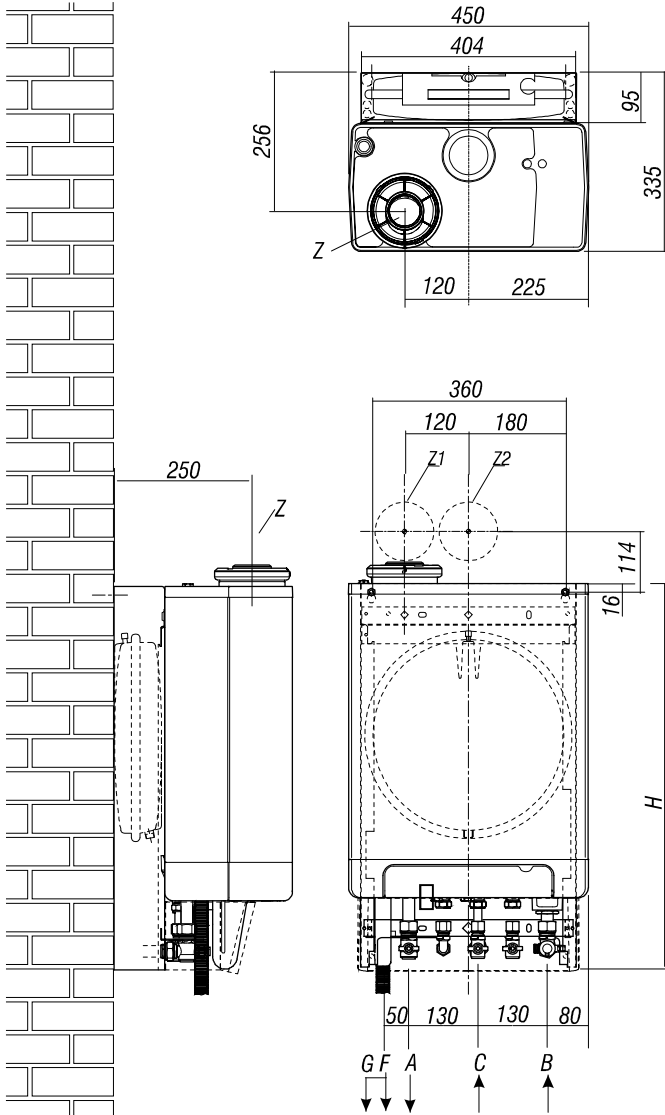

Appliance + wall mounting jig + bracket

| | | |
|-----|------------------------|---------------------------|
| A = | Supply CH | Ø22 |
| B = | Return CH | Ø22 |
| C = | Gas | ½" |
| F = | Condensate drain | Ø25 (flexible) |
| G = | Drain PRV | Ø15 |
| H = | 840 (*) | Compact HRE SB 30 & SB 40 |
| H = | 780 | Compact HRE SB 24 |
| H = | 720 | Compact HRE SB 18 |
| Z = | Flue pipe / air supply | Ø60/100 (concentric) |

(*) Note: The condensate trap of the SB 40 protrudes below pipe cover and wall mounting frame.

7.2 Installation location

- If the boiler is to be installed in any room or compartment, it does not require any purpose made ventilation for combustion air. If sited in a room containing a bath or shower then particular reference is drawn to the current I.E.E. Wiring Regulations, local Building Regulations or any other local regulations currently in service.
- The boiler is not suitable for external installation unless protected by a purpose made building such as a boiler house.
- The following clearances are recommended for installation purposes: 200mm above, 300mm below and 10mm at each side. 500mm is required at the front but this may be realized by opening a cupboard door.
- Flammable fluids and materials must be stored at least 1m away from the boiler
- The wall on which the boiler is mounted must be sufficiently strong to support the weight of the boiler.

7.2.1 Installing in a kitchen cupboard

The appliance can be installed between two kitchen cabinets or in a cabinet. Ensure sufficient ventilation at top and bottom. When installed in a cabinet, ventilation openings of at least 50 cm² must be created at the top and bottom of the appliance to ensure free flow of air.

7.2.2 Removing cover plate and front panel

For various work on the appliance the cover plate and front panel should be removed from the appliance. Proceed as follows:

- If cover plate (A), is used, remove to the front.
- Unscrew the two screws (1) behind the appliance display window.
- Pull the bottom of the front panel (2) forwards.

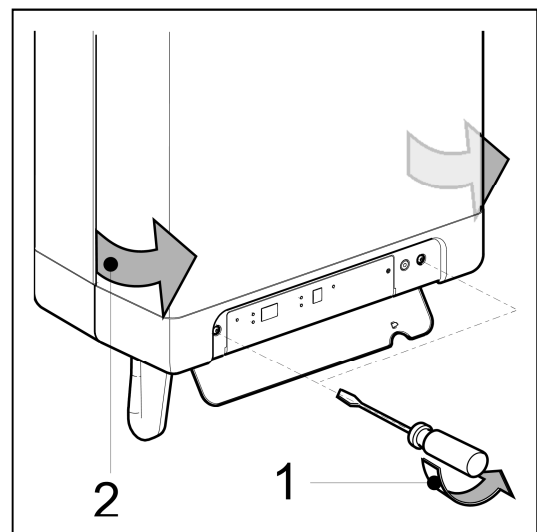
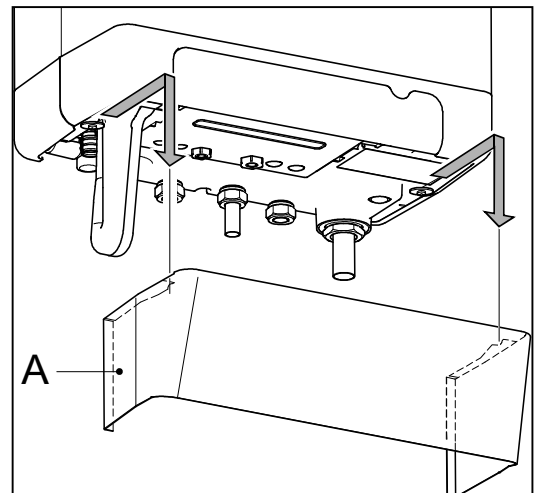
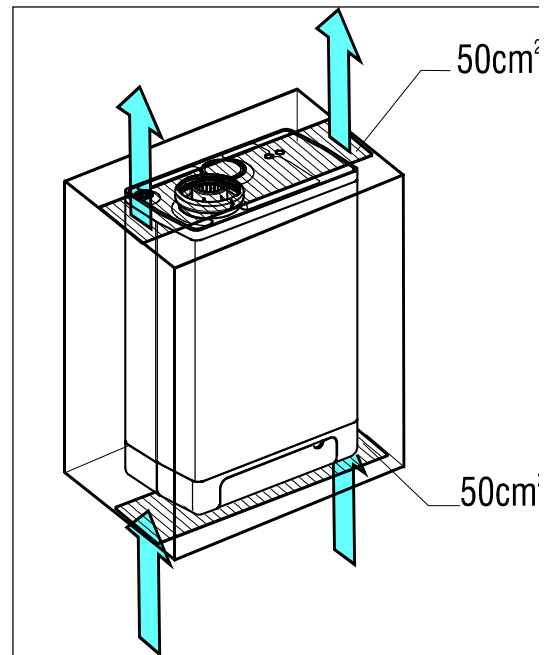

7.3 Assembly

The boiler can be mounted either on the fixing strip which is supplied in the box or to a wall mounting jig with an expansion vessel.

The wall mounting jig includes an expansion vessel and shut off valves.

If the fixing strip is used an external ROBO kit must be fitted as well.

7.3.1 Using the wall mounting jig

- Using the fastening materials supplied, secure the jig vertically to the wall. Make sure the wall is suitable for placing the boiler.
- Secure the bracket with the shut-off valves in the jig by inserting it with the flanged side upwards through the openings (sleeves) in the jig.
N.B. The appliance is wider than the jig.
- Install the CH heating system to the valves (DHW connections remain unused).



NOTE

All valves, with the exception of the return valve must be in a vertical position for open. The return valve must be in horizontal position for open.



CAUTION

Make sure that the boiler connections of the shut off valves remain in the correct position (= straight upwards). Except the return valve on the wall mounting jig which is horizontal when open. Do not over tighten connections. Do not turn tightened valves on pipes as this weakens joints within the boiler.

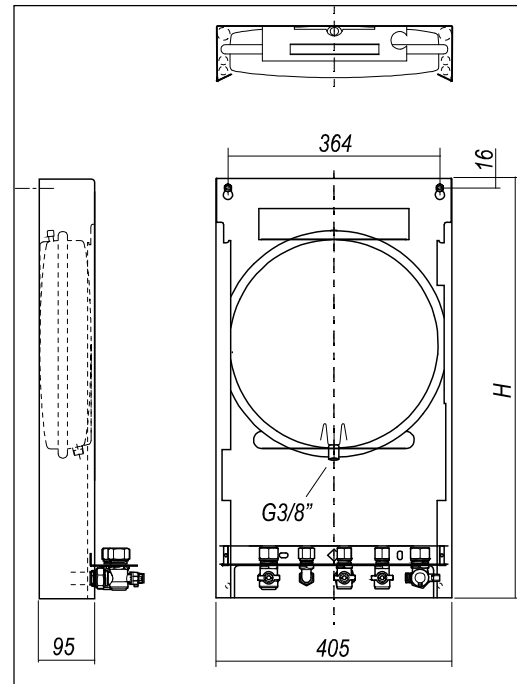

| | | |
|----|-----|---------------------------|
| H= | 840 | Compact HRE SB 30 & SB 40 |
| H= | 780 | Compact HRE SB 24 |
| H= | 720 | Compact HRE SB 18 |

7.3.2 Using the fixing strip + ROBO kit

- Position the fixing strip to the wall and drill the holes.
- Using appropriate fixing materials, secure the strip horizontally to the wall. Make sure the wall is suitable for placing the boiler.
- Hang the boiler on the fixing strip and connect the ROBO kit to the boiler and installation.

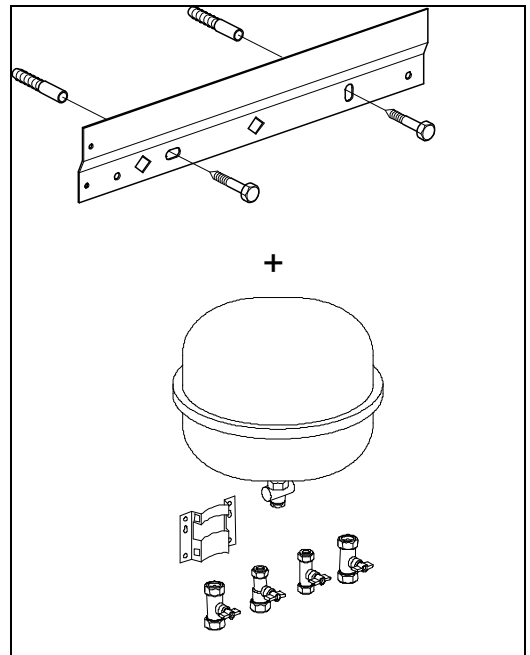

7.4 Installing the appliance

1. Unpack the appliance.
1. Check the contents of the packaging. It consists of:
 - Appliance (A)
 - Fixing strip (B)
 - Condensate trap (C)
 - Installation instructions and operating instructions
 - Warranty card
 - Templates for either wall or jig mounting
2. Check the appliance for possible damage: report damage immediately to the supplier.
3. Decide either to use the fixing strip (supplied) or wall mounting jig.
4. The templates show the positions for the horizontal flue. Drill the exit holes, being sure to prevent dust or debris from entering the boiler or pipe-work.
5. If the fixing strip is secured to the wall then slide the boiler down until latched.
6. If the jig is fixed securely to the wall then it is possible to fit the pipe connections prior to hanging the boiler. Pipe connections are (from right to left) as follows for both methods: PRV 15 mm – CH flow 22mm – Gas 22 mm – Return 22 mm. **IMPORTANT. The gas supply should be minimum 22mm up to gas isolation valve on boiler.** It is the installers responsibility to ensure sufficient gas supply.
7. Check whether the compression rings are sitting squarely in the mounting bracket couplings.
8. Fit the appliance, sliding it downwards on the jig. Ensure at the same time that the pipes slide into the compression fittings.
9. Tighten the compression fittings on the mounting bracket. Do not turn tightened valves on pipes as this weakens joints within the boiler.
10. Fit the flexible tube to the condensate trap outlet.
11. Fill the condensate trap with water and slide it as far as possible upwards on to the condensate drain connector below the appliance.

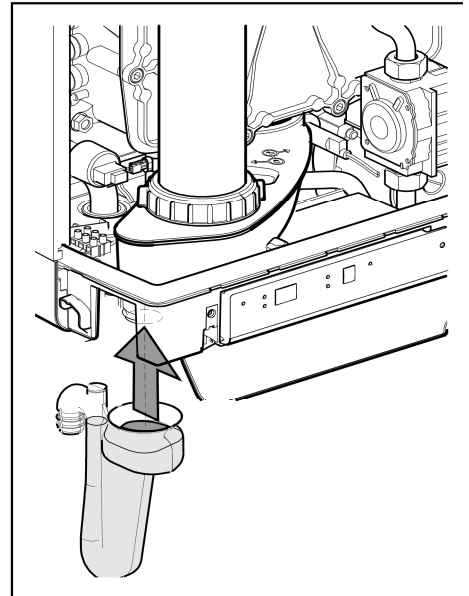
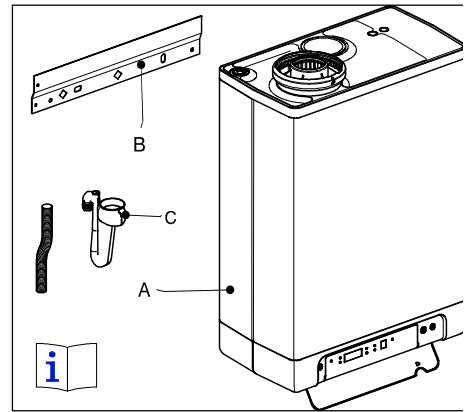

CAUTION

The Compact HRE 40 SB is only to be installed with the condensate trap (length =235 mm) included in the boiler package.

When replacing the condensate trap make sure the correct version is ordered (art.nr. 844787). Using an incorrect condensate trap can lead to potentially unsafe situations.

12. Connect the flexible tube from the condensate trap to the drain via an open connection. The condensate discharge system must be made of plastic, no other materials may be used. The discharge duct must have a minimum gradient of 5 – 20 mm/m. Condensate discharge via the gutter is not allowed given the risk of frost and the possible damage to materials.
13. Fit the flue in accordance with the instructions mentioned in § 8.4.4. Allow 15mm of white tube externally to ensure the flue sealing ring is fitted correctly. No white part of the flue should be visible externally once the black sealing ring is fitted correctly.



CAUTION

Always fill the condensate trap with water and place it on the boiler before powering up the boiler.

Not placing or filling up the condensate trap may cause flue gases to come into the installation room and can lead to dangerous situations!

In order to place the condensate trap the front cover must be pulled forward or removed entirely.



NOTE

It is recommended that any external condensate pipe is insulated and increased to 32mm diameter in order to prevent the condensate from freezing.

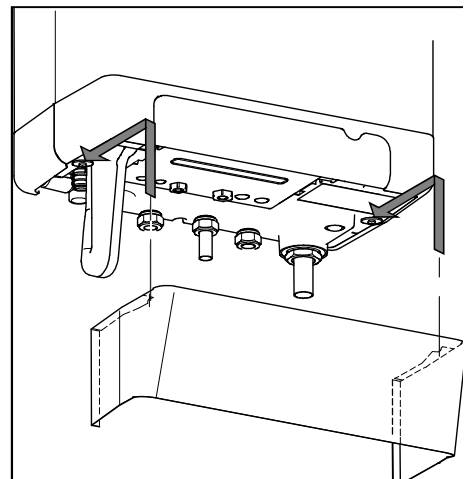

7.4.1 Fitting the cover plate (optional)

Hang the flanged upper edge of the cover plate on the washers under the base of the appliance and slide the cover plate as far as possible towards the rear.

8 CONNECTION

8.1 Connecting CH installation

1. Flush the CH system thoroughly to clean.
2. Fit the flow and the return pipe into the shut off valves.
3. All pipes must be fitted unstressed in order to prevent the pipes from ticking.
4. Existing connections must not be twisted, in order to avoid leakages.
Make sure the compression fittings are tightened thoroughly to prevent leakage.

8.1.1 The CH system should be equipped with:

- A drain tap in the return pipe immediately below the appliance.
- (A drain off is included on the wall mounting jig)
- A drain tap at the lowest point(s) of the installation.

8.1.2 Thermostatic radiator valves

If all radiators are equipped with thermostatic or radiator valves, an auto bypass must be fitted in order to guarantee minimum water circulation. The auto bypass must be at a distance of at least 20 ft from the appliance in order to prevent overheating of the appliance. A radiator without thermostatic valves is **not** a suitable by-pass.

8.1.3 Weather compensation and heating DHW cylinder on hot water priority or W system

When connecting a Compact HRE SB to an indirectly heated DHW storage cylinder the following parts can be ordered:

- DHW storage cylinder sensor (art. nr. 065.117)
- Diverter valve 230V (art. nr. 092.647)

Connect the DHW storage cylinder and diverter valve according to the diagram. Remove the loop in 9 – 10 to connector X4. Connect the diverter valve to connector X2 and connect the DHW storage cylinder sensor or thermostat to connector X4 according to the electrical diagram (See chapter 13).

Electrical diagram indirectly heated DHW storage cylinder

- C. Boiler
- D. DHW storage cylinder
- E. Radiator
- F. Expansion vessel
- G. Pressure relief valve 3 Bar
- H. Diverter valve
- I. DHW storage cylinder sensor or thermostat

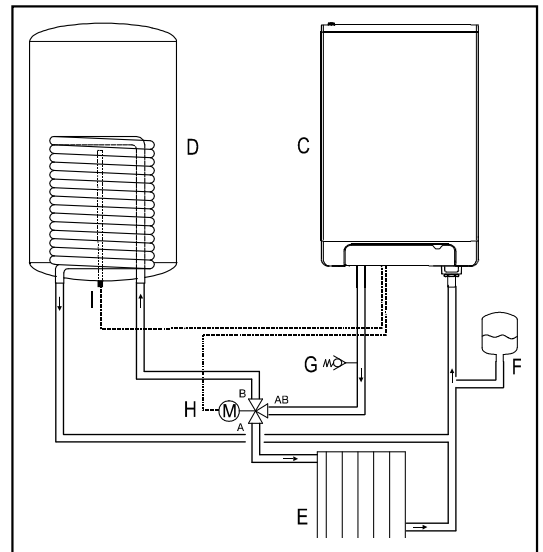

NOTE

When using a DHW storage cylinder thermostat the heating demand will start with opening the thermostat and end when the thermostat closes.

8.2 Electrical connection



CAUTION

A 3 amp fused spur or an unswitched socket must be located no more than 1 metre from the appliance.



For installation in damp rooms a fixed connection is obligatory.

When working on the electrical circuit always isolate the electric supply.

1. Slide the cover plate (A) (if present) to the front to remove.
2. Open the display cover and unscrew both screws to remove the front cover.
3. Pull the boiler controller unit forwards; the boiler controller will tip downwards to provide access.
4. Consult sections § 8.3.1 and chapter 13 for making the connections.
5. After making the desired connections plug the appliance into an earthed unswitched wall socket or connect to a fused switched spur..

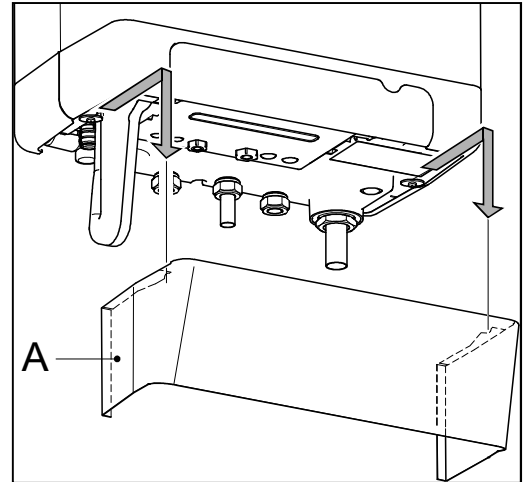

8.2.1 Electrical connections

| Temperature control | Connector X4 | Notes |
|-----------------------------|--------------|----------------------------------|
| Room thermostat | 6 – 7 | Voltage free. Remove link 6-7 |
| Outside temperature sensor | 8 – 9 | - |
| Frost protection thermostat | 6 – 7 | Parallel to room thermostat |
| Open Therm (OT) | 11 – 12 | Remove link 6-7 |

| Temperature control | Connector X2 | Notes |
|--|--------------|----------------------------------|
| Room thermostat 230 V or external control 230 V. | 1 – 3 | Remove link 6 – 7 (connector X4) |
| Frost thermostat 230 V | 1 – 3 | Remove link 6 – 7 (connector X4) |

Switch live from S-plan or Y-plan onto connector X2, no.1.
See chapter 13.3 and 13.4 for complete electrical schedules.

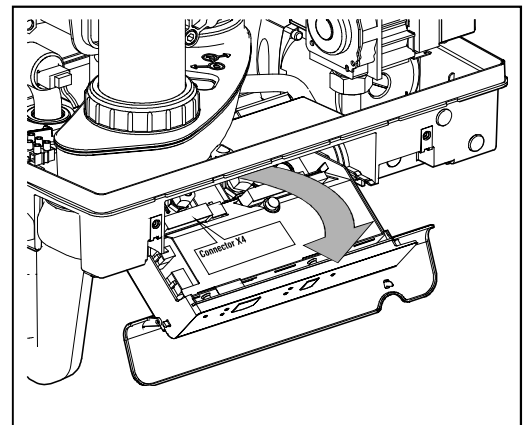
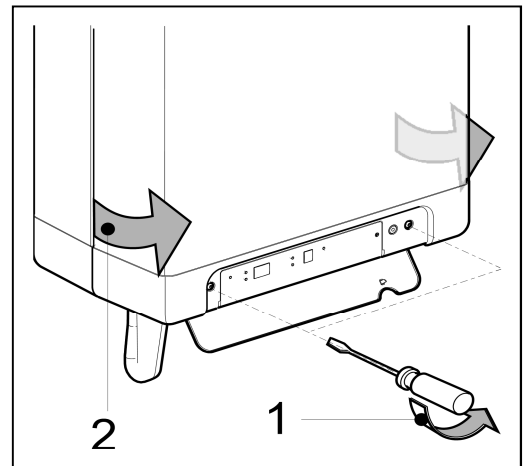

8.2.2 On / off room thermostat (low voltage)

To be connected to contacts 6 and 7 of connector X4.
This is a 24 volt connection and no mains power must be applied to these terminals.
See chapter 13, electrical diagram.



NOTE

When a 24 volt thermostat is connected to contacts 6 and 7, the loop in 6 – 7 must be removed.

1. The on/off room thermostat has to be connected to the contacts 6 and 7 of connector X4.
2. Adjust the feedback resistance of the room thermostat to 0.1 A. In case of doubt measure
3. the current and adjust this accordingly.
4. The allowed maximum electrical resistance of the room thermostat and wiring is 15 Ohm.

8.2.3 Open Therm room thermostat

Open therm is a protocol that enables the boiler and the room thermostat to communicate. Based on the information from the room thermostat the flow temperature of the boiler is adjusted to the most optimal value.

The Open Therm (OT) room thermostat has to be connected to the contacts 11 and 12 of connector X4 (see chapter 13, electrical diagram).



CAUTION

Connecting the Open Therm room thermostat to other contacts than 11 – 12 may damage the room thermostat !



NOTE

When an Open Therm thermostat is connected to contacts 11 and 12, of connector X4 the loop in 6 – 7 must be removed.

8.2.4 Outside temperature sensor

The appliance is equipped with a connection for an outside temperature sensor. The outside temperature sensor can be used in combination with an on/off room thermostat or an OpenTherm thermostat.

Connect the outside temperature sensor (See § 8.3.1).

For the heating line setting, see weather-dependent regulation (See § 10.6).

8.2.5 230 volt room thermostat

To be connected to contacts 1 and 3 of connector X2.
See electrical diagram.



NOTE

When a 230 V thermostat is connected, link in 6 – 7 of connector X4 must be removed.



Warning High Voltage

Isolate the appliance from the electrical supply before connecting the thermostat.

8.3 Condensate disposal

The appliance is provided with a 25 mm flexible pipe from its condensate trap. Connect the flexible tube from the condensate to the drain via an open connection.



CAUTION

Always fill the condensate trap with water and place it on the boiler before powering up the boiler.

Not placing or filling up the condensate trap may cause flue gases to come into the installation room and can lead to dangerous situations!

In order to place the condensate trap the front cover must be pulled forward or removed entirely.

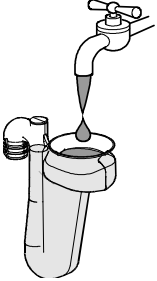

The condensate discharge system, pipework and fittings must be made of plastic. No other materials may be used. The discharge duct must have a minimum gradient of 5 – 20 mm/m throughout its length. Condensate discharge via the gutter is not allowed given the risk of frost and the possible damage to materials

- A. Internal stack pipe (see diagram)
- B. Gully
- C. Condensate discharge from boiler
- D. Servicable waste trap
- E. 5 – 20 mm/meter
- F. > 100 mm
- G. > 110 mm
- H. > 450 mm

If an externally-run condensate drainage pipe is used the following measures should be adopted to prevent freezing:

- The pipe should be run internally as far as possible before going externally, the pipe diameter should be increased to a minimum of 30mm ID (typically 32mm OD) before it passes through the wall.
- The external run should be kept as short as possible, taking the most vertical route possible to the discharge point, with no horizontal sections in which condensate might collect.
- The external pipe should be insulated using suitable waterproof and weatherproof insulation ("Class O" pipe insulation is suitable for this purpose)
- The use of fittings, elbows etc should be kept to a minimum and any internal "burrs" on cut pipework should be removed so that the internal pipe section is as smooth as possible.

For more information about preventive measures against freezing please visit the HHIC website <http://www.centralheating.co.uk/checklists/frozen-condensate-pipes>.

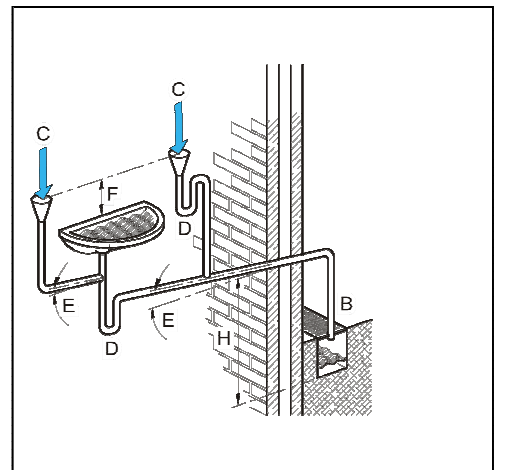
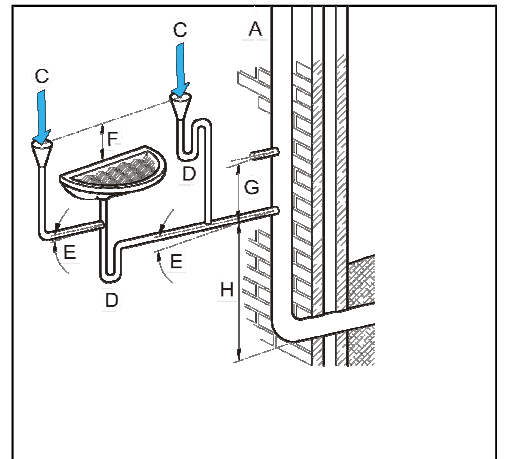

8.4 Flue System

8.4.1 Flue pipe and air supply

The boiler utilises a special concentric flue adapter which can only be used with the elbow that is part of the horizontal flue pipes. For the appropriate types see chapter 6 Accessories.

When using a vertical flue system the adapter on the boiler has to be replaced with the adapter 60/100 included in the vertical roof terminal, Intergas article number 082973.

When using a vertical flue system to reach an higher positioned wall terminal the adapter on the boiler has to be replaced with the adapter 60/100, Intergas article number 090547.



NOTE

Only use approved Intergas flue products with this boiler, which can be sourced from the supplier of your boiler or Intergas stockist.

The standard horizontal flue pipe is not supplied with the boiler and should be purchased separately from your supplier. This flue may be routed to the rear, left or right of the appliance by means of the 90° degree bend, which is supplied in the flue kit.

8.4.2 Flue pipe position

| | Terminal Position | Min. distance |
|----|---|---------------|
| A | Directly below an open able window or other opening e.g. air brick | 300 mm |
| B | Below gutters, soil pipes or drain pipes | 75 mm |
| C | Below eaves | 200 mm |
| D | Below balconies or car front roofs | 200 mm |
| E | From vertical drain pipes and soil pip | 150 mm |
| F | From internal or external corners | 300 mm |
| G | Above ground, roof or balcony level | 300 mm |
| H | From a surface facing a terminal | 600 mm |
| I | From a terminal discharging towards another terminal | 1200 mm |
| J | From an opening in a car port (e.g. door, window) into a dwelling | 1200 mm |
| K | Vertically from a terminal on the same wall | 1500 mm |
| L | Horizontally from a terminal on the same wall | 300 mm |
| M | Above an opening, air brick, opening windows, etc. | 300 mm |
| N | Horizontally to an opening, air brick, opening windows, etc. | 300 mm |
| P | Above roof level (to base of terminal) | 300 mm |
| Q | From adjacent wall to flue | 300 mm |
| R | From an adjacent opening window | 1000 mm |
| S | From another roof terminal | 600 mm |
| - | From an external boundary. Note: if the terminal is facing a boundary it is recommended that an anti-plume kit be fitted. | 600 mm |
| T | Terminals adjacent to windows or openings on pitched and flat roofs: The flue should not penetrate this area. | |
| T1 | | 2000 mm |
| T2 | | 600 mm |

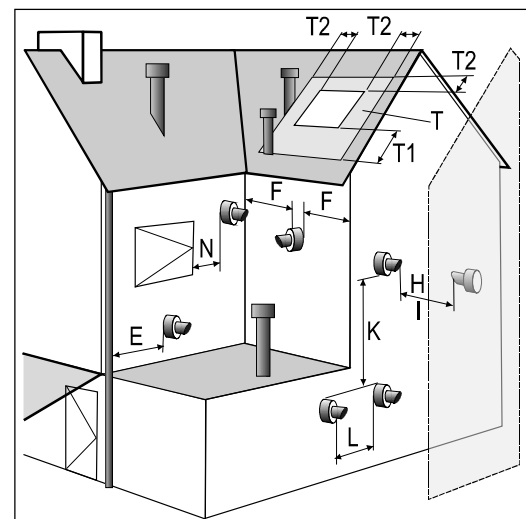
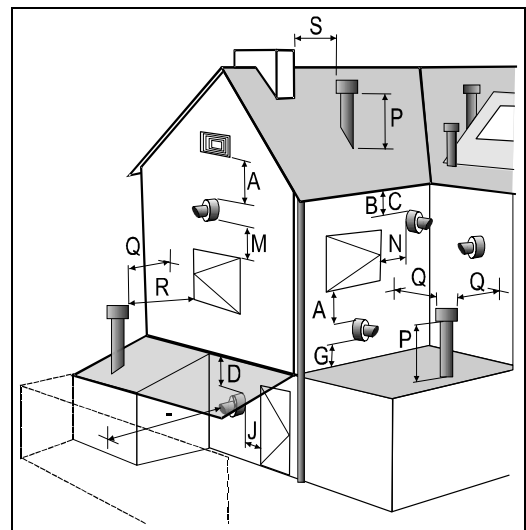

N.B. Intergas cannot be held responsible for atmospheric conditions when siting flue terminals



CAUTION

Once the flue has been installed and the appliance commissioned, installer should observe the plume direction. Particular attention should be drawn to plume vapour re-entering the boiler via the air intake. If this occurs, it is highly possible the flue is fitted within a negative pressure area and therefore a plume management kit (PMK) must be fitted.

8.4.3 Length flue pipe and air inlet

The following lengths (L = meters) for the combustion system are valid:

HRE 18 SB

| C13(1) | C33(2) | C13(1) | C33(2) | C53(3) | | C33(4) | |
|--------|--------|---------|---------|--------|----|--------|------|
| 60/100 | 60/100 | Twin-80 | Twin-80 | 60/100 | 60 | 60/100 | 80 |
| L | L | L | L | L1 | L2 | L1 | L2 |
| 10.2 | 11 | 37.6 | 37.6 | 7 | 1 | 9 | 1 |
| | | | | 1 | 12 | 1 | 33.7 |

HRE 24 SB

| C13(1) | C33(2) | C13(1) | C33(2) | C53(3) | | C33(4) | |
|--------|--------|---------|---------|--------|----|--------|------|
| 60/100 | 60/100 | Twin-80 | Twin-80 | 60/100 | 60 | 60/100 | 80 |
| L | L | L | L | L1 | L2 | L1 | L2 |
| 9.7 | 10 | 29.8 | 29.8 | 6.5 | 1 | 9 | 1 |
| | | | | 1 | 10 | 1 | 31.2 |

HRE 30 SB & 40 SB

| C13(1) | C33(2) | C13(1) | C33(2) | C53(3) | | C33(4) | |
|--------|--------|---------|---------|--------|----|--------|----|
| 60/100 | 60/100 | Twin-80 | Twin-80 | 60/100 | 60 | 60/100 | 80 |
| L | L | L | L | L1 | L2 | L1 | L2 |
| 9.7 | 10 | 21.3 | 21.3 | 6 | 1 | 9 | 1 |
| | | | | 1 | 10 | 1 | 30 |

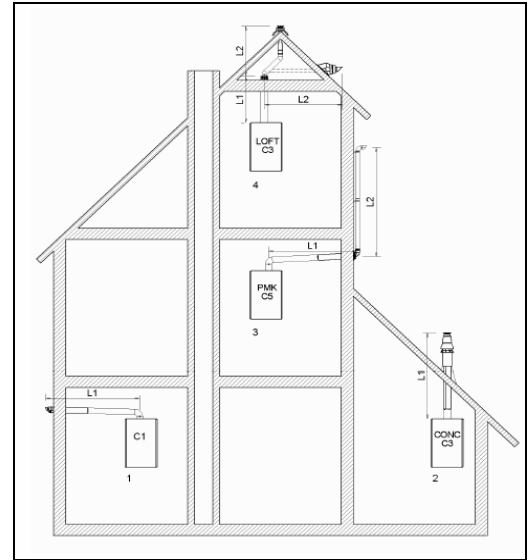

8.4.4 Horizontal flue system

The 60/100 mm horizontal flue system may be extended up to a maximum length as mentioned in the table above. For every bend used the following flue length reductions apply: - 45° bend = 1 metre and for a 90° bend this is 1.5 metres. Allow 15mm of white tube externally to ensure the flue sealing ring is fitted correctly. No white part of the flue should be visible externally



CAUTION

**Only an Intergas approved flue is to be used with this product.
Failure to comply with this requirement will invalidate your guarantee and may lead to a dangerous situation!**

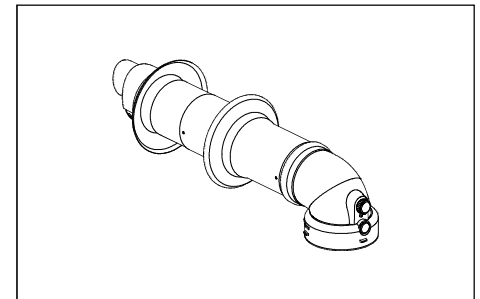

The wall terminal must be installed horizontally.

The horizontal wall terminal must be installed level as the flue terminal already has a 3 degree rise built in. If the use of flue extensions are needed then they must be fitted with a 3 degree fall back to the boiler and have a bracket fitted every meter to support the flue. Best recommended position of the bracket is just before the joint.

8.4.5 Vertical flue system

A vertical 60/100 mm flue kit is also available, which can be extended up to a maximum of 10 metres, excluding the initial boiler connection, using additional components available from the supplier of your boiler or Intergas stockist.

The vertical flue system contains a flue adapter concentric 60/100 to replace the standard adapter on the boiler.

Please note that the terminal is suitable for a flat or pitched roof and only approved Intergas flue products can be used with this boiler.

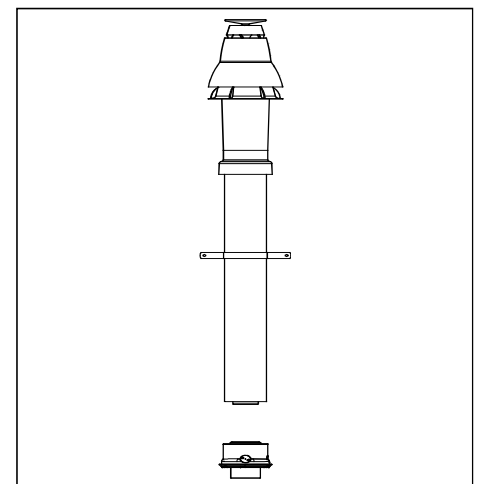

8.4.6 Plume management kit

The plume management kit comprises of a 710 mm horizontal section with elbow to connect the 1m vertical condensing tube, which has a horizontal or vertical terminal dependant on your requirements. The maximum length of horizontal flue including the terminal but excluding the initial elbow from the boiler and 1 metre vertical condensing tube is 8 metre.



NOTE

For each additional 90° elbow used the maximum flue length must be reduced by 1.5 metre, whilst the use of 2 x 45° bends warrants a reduction of 2 metre.

The horizontal part of the flue must be installed under a 3° fall towards the boiler (50 mm per metre) and must be supported with a minimum of 1 bracket at each meter length. Best recommended position of the bracket is just before the joint.

8.4.7 Flues in voids

The flue system must be connected in accordance with the manufacturers instructions BEFORE firing the boiler.



CAUTION

- Sealing rings should only be moisturized with water before use. Do not use soap or other detergents.
- When installing flues in voids make sure they are connected and fixed correctly. If in an existing situation a visual inspection is not possible the boiler must not be commissioned and remain disconnected from the gas supply until suitable access has been realised.
- Make sure to follow the manufacturer's instructions regarding maximum length of the flue system, the appropriate flue material, correct jointing methods and the maximum distance between flue support.
- Ensure that all joints and seams are gastight and watertight.
- Ensure the flue system has a uniform gradient back to the boiler.

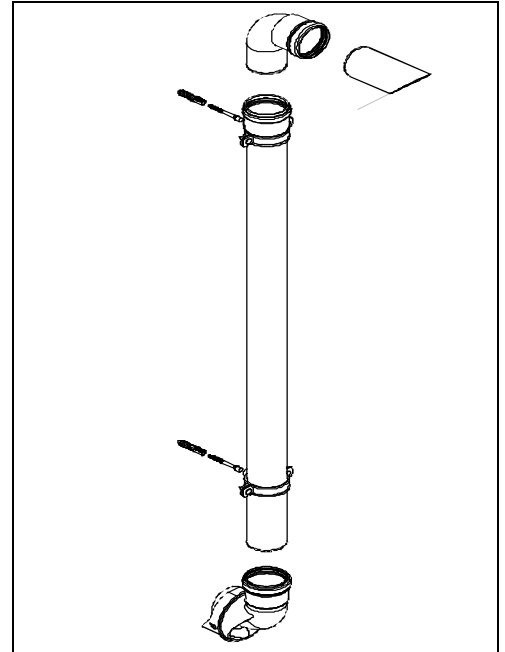

The term void includes ceiling voids, floor voids, purpose built enclosures, service risers, roof spaces or any other enclosure that will restrict access to inspect the flue.

To allow visual inspection, without reliance on devices such as endoscopes, cameras and mirrors, inspection hatches must be provided along the entire length of the flue.

Hatches must be a minimum of 300mm x 300mm and positioned with the edge of the inspection hatch to 1.5m of any joint and at changes of direction. Bends should be viewable from both directions where the inspection hatch cannot be positioned at the bend.

Where suitable access is not provided the appliance MUST NOT be commissioned and must be disconnected from the gas supply.

Additionally the entire flue and all flue seals must be installed in accordance with the requirements of BS5440:

1. Check condensate trap is filled with water and correctly connected to boiler.
2. All flue joints are correctly made, unstressed and adequately supported.
3. All parts of the flue can be visually inspected -ensure suitable access where flue is positioned within voids-

9 COMMISSIONING THE APPLIANCE

At the time of commissioning, complete all relevant sections of the Benchmark Checklist located in section 17 of this document.

9.1 Filling and venting the appliance and the installation

9.1.1 CH system



CAUTION

When an additive is added to the CH water, ensure it is suitable for the materials used in the appliance, such as copper, brass, stainless steel, steel, plastic and rubber.

1. Connect to 3 amp fused spur, or via a three pin plug to an unswitched socket.
2. Connect the appliance to mains.
The appliance may perform a self test: (on service display).
The appliance will then go into wait mode: (on service display).
14. Connect the filling loop and fill the installation with clean drinking water to a maximum pressure of 1-2 bar in the case of a cold installation. (Indicated on the temperature & display.)
15. Bleed the appliance with the manual bleed screw (A).
An automatic air bleeding device may be fitted to the appliance in place of the manual bleed screw.
16. Bleed the air in the installation with the manual bleed screws on the radiators.
17. Top up the CH installation if the pressure has dropped too far as a result of the air bleeding.
18. Check all couplings for leakage.
19. Fill the condensate trap with water.

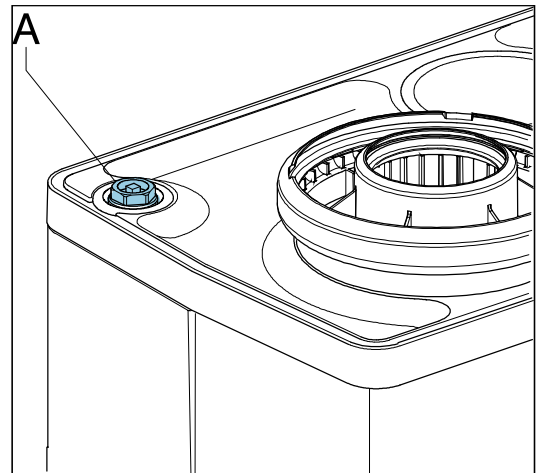

9.1.2 Hot water supply (only when an indirectly heated DHW storage cylinder is applied)

1. Open the main tap to pressurise the hot water section.
2. Vent the exchanger and the pipe system by opening a hot water tap.
3. Leave the tap open until all air has disappeared from the system.
4. Check all connections for leaks including internal connections.

9.1.3 Gas supply

1. Gas supply purged of air via test point D on gas valve (see illustration)
2. Connect a suitable gauge to test point D .
Static or standing pressure must be 20mb. **If 20mb is not obtained DO NOT proceed with commissioning until supply is rectified.**
3. If static pressure is correct fire the boiler and allow to reach working temperature.
4. Test working pressure by selecting test program "H". See § 10.8.1 , High Setting. Working pressure must be 20mb



NOTE

The inlet working pressure must be obtained with all other gas appliances at the property working.

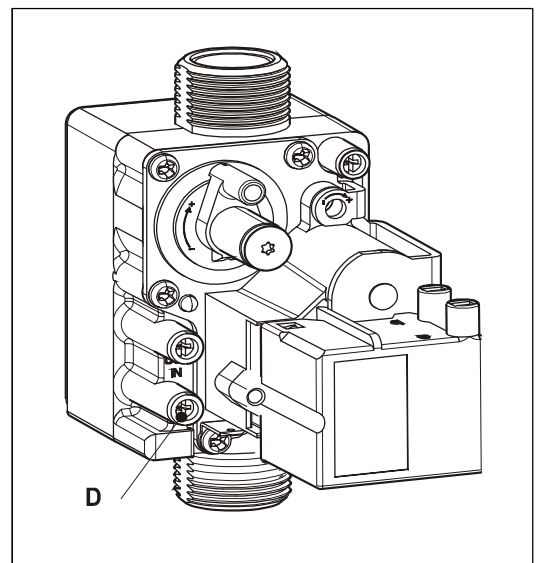

9.1.4 Combustion

The combustion for this appliance has been checked, adjusted and preset at the factory for operation on the gas type defined on the appliance data plate. Do not adjust the air/gas ratio valve.

Having checked:

- That the boiler has been installed in accordance with these instructions;
 - The integrity of the flue system and the flue seal, as described in § 8.4 and the British Standards codes of practices, specifically BS 5440;
 - The integrity of the boiler combustion circuit and the relevant seals, as described in § 0 eg. with a flue spillage mirror;
- proceed to put the boiler into operation as follows:

1. Set up the boiler to operate at maximum rate as described in § 10.8.1.
2. With the boiler operating in the maximum rate condition check that the CO₂ percentage measured at sampling point (X) complies with the requirements as described in the table under § 10.8.1.

Ensure that this inlet pressure can be obtained with all other gas appliances in the property working.

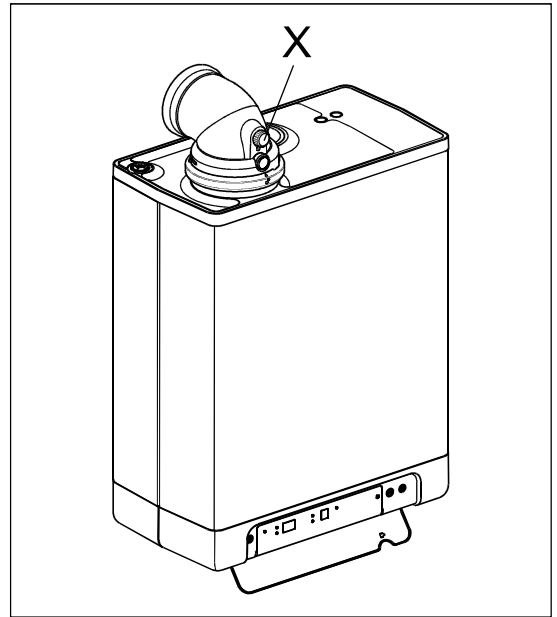

9.1.5 Flue system

The flue system must be connected correctly to the appliance in accordance with the manufacturer's instructions. The flue termination should also be checked. Where suitable access for a visual inspection of an existing flue system has not been provided the appliance must not be commissioned and it must be disconnected from the gas supply.

Allow 15mm of white tube externally to ensure the black external sealing ring is fitted correctly. No white parts of the flue pipe should be visible externally. Correct fitting of the flue seal as shown in the flue fitting instruction included in the flue package.

9.2 Commissioning the appliance

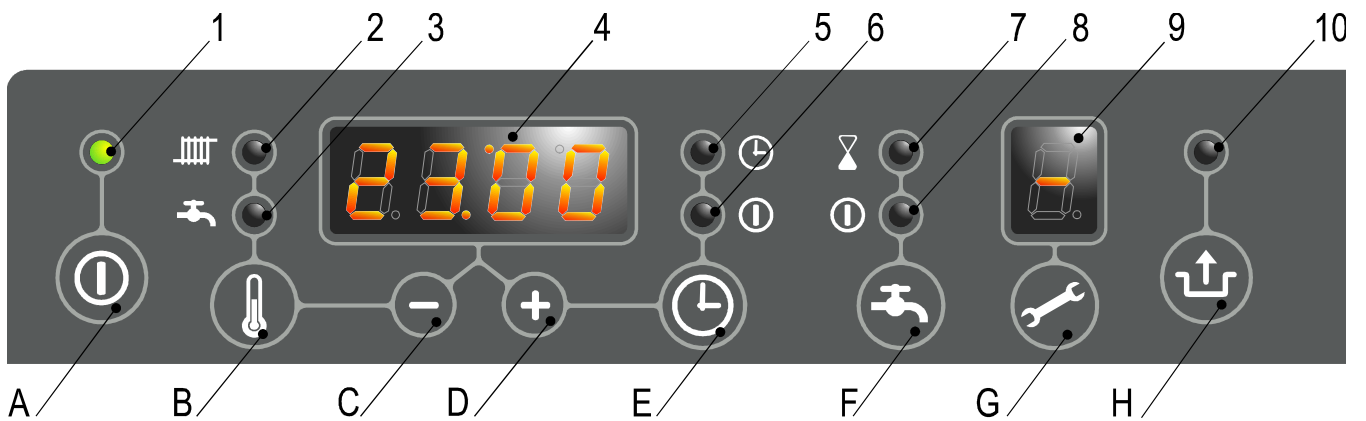

Read-out

- 1 On / off
- 2 CH operation or setting maximum CH temperature
- 3 DHW operation or setting DHW temperature (not applicable for Compact HRE SB)
- 4 Desired temperature of CH or DHW in °C / Ch water pressure (bar) / Fault code/ Time
- 5 Clock "on" CH enabled
- 6 Clock "off" CH disabled
- 7 DHW comfort function eco (not applicable for Compact HRE SB)
- 8 DHW comfort function on (continuous) (not applicable for Compact HRE SB)
- 9 Operating code
- 10 Flashes to indicate fault

Operation

- A On / Off button
- B DHW / CH button, for setting desired temperature
- C - button
- D + button
- E Clock function setting
- F DHW comfort function off/eco/on (not applicable for Compact HRE SB)
- G Service button
- H Reset button

Once the preceding actions have been carried out, the appliance may be started up.

1. Press the **A** button, to start the appliance.
2. Adjust the pump setting depending on the maximum power set and the resistance in the CH installation. For the water head of the pump and the pressure loss of the appliance see § 10.5.
3. Set the room thermostat higher than the room temperature. The appliance will now switch to CH operation: **5** will show on the display.
4. Heat the installation and the appliance to approximately 80°C.
5. Check the temperature difference between the supply and return for the appliance and the radiators. This must be approximately 20°C. For this purpose set the maximum power on the service panel. See setting maximum power. If necessary adjust the pump setting and/or the radiator valves. For the minimum flow see § 10.5.
20. Switch the appliance off.
21. Bleed the appliance and the installation after cooling (if necessary top up).
22. Check correct operation of the heating and hot water supply.
23. Instruct the user on filling, bleeding and the operation of the clock, heating and hot water supply. For setting the clock see § 9.3. Note: for S and Y plans the clock will be set to C-ON to allow the external timer/programmer to operate the CH and DHW cylinder separately or together.



NOTE

- *The appliance is equipped with an electronic boiler controller, which ignites the burner and continuously monitors the flame during each request for heat from the heating or from the hot water supply.*
- *The circulation pump starts running in response to every request for heat. The pump continues running for 1 minute after heating. This post purge period can be changed if desired (See § 10.3.).*
- *The pump runs automatically for 10 seconds every 24 hours in order to prevent seizing. This will occur at the the time of the last request for heat. To change this time the room thermostat should be turned up briefly at the desired time.*

9.3 Setting and adjusting the clock functions



NOTE







Setting and adjusting the clock is only applicable when using the boiler as “heat only” or in combination with a system as mentioned under § 8.1.3 .

When using a S and Y plan wired system the clock always has to be set on “C-on

9.3.1 Setting the clock

- Press the  button for less than 1 second and repeat this until “24hr clock” appears. For adjusting the clock to the correct time press the [+] or [-] button.
Note: Holding the button for more than 1 second will make the clock run fast.

9.3.2 Setting the timer function

- On pressing the  button for more than 2 seconds the clock display will flash.
- The time for each on/off shows in the clock display and the service display shows which on 1 and 3 OR off 2 and 4 time is being set.
- Pressing the  button again will change between the different on/off switching periods.
The pre-set times are as follows:
Display : [06:00] and [1] → Start first period CH on.
 [09:00] and [2] → End first period CH off.
 [16:00] and [3] → Start second period CH on.
 [22:00] and [4] → End second period CH off.
- By pressing the  button the new times will be stored in the boiler controller.
In the service display [P] appears.
- When the clock is in period [1] or [3] (CH ON) the clock symbol LED is on.
- When the clock is in period [2] or [4] (CH not active) the  LED is on.
- By pressing the  button over 5 seconds the default setting for the switch moments will be restored.
In the service display “F-set” appears.
- By pressing the  button the boiler controller will return to the normal situation without storing any changes.

9.4 Additional functions

- Pressing the  button for less than 1 second the following additional functions can be activated:
 - t-on (temporary on).
The boiler will respond on every CH demand from the room thermostat until the next switch moment.
 - c-on (continuous on).
The boiler will respond on every CH demand from the room thermostat without any time limit.
 - OFF
The boiler will not respond on any CH demand from the room thermostat.

9.5 Shutting down



CAUTION

Drain the appliance and the installation if mains power has been interrupted and there is a possibility of freezing.

1. Adjust all valves to manual operation.
2. Drain the appliance at the drain tap.
3. Drain the installation at the lowest point.

9.5.1 Frost protection

- To avoid freezing of the condensate drain pipe the appliance must be installed in a frost-free area.
- To avoid freezing of the appliance it is equipped with frost protection. If the temperature of the heat exchanger becomes too low, the burner switches on until the temperature of the heat exchanger is sufficient. If there is a possibility of the installation (or part of it) freezing, an (external) frost thermostat must be installed at the coldest point of the return pipe. This must be connected in accordance with the wiring diagram (See chapter 13).



NOTE

If an (external) frost thermostat has been fitted to the installation and connected to the appliance, this will not be active when the appliance is switched off at the operating panel ([-] on service  display).

10 SETTING AND ADJUSTMENT



The functioning of the appliance is determined primarily by the (parameter) settings in the boiler controller. Part of this can be set directly via the operating panel; another part can only be adjusted using the installer code.

10.1 Directly via the operating panel



The following functions can be operated directly:

10.1.1 Appliance on/off







The appliance is started using the  key.

When the appliance is in operation the green LED above the  key will light up. When the appliance is off a single dash lights up on the service display () to indicate that supply voltage is present. In this mode the pressure in the CH installation (in bar) can also be read on the temperature display.

10.1.2 Resetting

When a lock-out is indicated by means of a flashing LED above the  key and a code on the  display, the appliance can be restarted by pressing the  key. Check the nature of the fault on the basis of the fault codes in § 11.1 and resolve the cause of the fault if possible before resetting the appliance.

10.1.3 Changing the settings of the various functions:



Holding the  key pressed in for 2 seconds takes you to the user settings menu (LED at  and the figure display start to flash). Pressing the  key repeatedly results in a different function LED flashing each time. When the LED is flashing the indicated function can be set with the  and  key. The value set is shown on the  display.



The  on/off key closes the settings menu without storing the changes.

The reset  key closes the settings menu and the changes are stored.

If no key is pressed during a period of 30 seconds, the settings menu is closed automatically and the changes are stored.

10.1.4 Maximum CH supply temperature









Press the  key until the LED at  starts to flash.

With the  and  keys set the temperature between 30°C and 90°C (default value 80°C).

10.2 Setting via the service code

The boiler controller in the appliance is factory set in accordance with the parameters.

These parameters can only be changed using the service code. Proceed as follows to activate the program memory:

1. Press the  and  keys simultaneously until a 0 appears on the service- and temperature display.
2. Using the  and  keys set 15 (service code) on the temperature display.
3. Using the  key select the parameter to be set on the service display.
4. Using the  and  keys set the parameter to the desired value (visible) on the temperature display.
5. Once all desired changes have been entered, press the  key until a P appears on the service display.

The boiler controller has now been reprogrammed.

- Pressing the  key in takes you out of the menu without storing the parameter changes.

10.3 Parameters

| Setting | Compact HRE SB Factory settings | | | | Description | Par. |
|---|------------------------------------|----|----|-----|--|------|
| | 18 | 24 | 30 | 40 | | |
| Service code [15] | - | - | - | - | Access to installer settings The service code must be entered (= 15) | 0 |
| Installation type | 3 | 3 | 3 | 3 | 0= Combi 1= Heating only + external DHW tank , see § 8.2 2= DHW only (no heating system required) 3= Heating only (for S and Y Plans) | 1 |
| CH pump continuous | 0 | 0 | 0 | 0 | 0= post purge period only 1= pump continuously active 2= pump continuously active with MIT switch 3= pump on with external switch | 2 |
| Maximum CH power set | 85 | 85 | 85 | 99 | Adjustment range of set value parameter c up to 85% or up to 99 (HRE SB40 only) | 3 |
| Max. power modulating pump | 80 | 80 | 80 | 100 | Adjustment range = value of parameter c. until 100% | 3. |
| Maximum DHW power set | 85 | 85 | 85 | 75 | Adjustment range of set value parameter d up to 99% or 75 % (HRE SB 40 only) | 4 |
| Min. supply temperature of the heat curve | 25 | 25 | 25 | 25 | Adjustment range 10°C to 25°C | 5 |
| Max. value flow temperature in display (end user setting) | 90 | 90 | 90 | 90 | Adjustment range 30°C to 90°C | 5. |
| Min. outside temperature of the heat curve | -7 | -7 | -7 | -7 | Adjustment range -9°C to 10°C | 6 |
| Max. outside temperature of the heat curve | 25 | 25 | 25 | 25 | Adjustment range 15°C to 30°C | 7 |
| CH pump post purge period | 1 | 1 | 1 | 1 | Adjustment range 0 to 15 minutes | 8 |
| CH pump post purge period after DHW operation, see & 8.2 | 1 | 1 | 1 | 1 | Adjustment range 0 to 15 minutes (N.a. for Combi Compact appliance) | 9 |
| Booster | 0 | 0 | 0 | 0 | N.a. | b |
| Step modulation | 1 | 1 | 1 | 1 | 0= step modulation off during CH operation 1= step modulation on during CH operation | C |
| Minimal CH rpm | 30 | 25 | 25 | 20 | Adjustment range 25 to 50 % | c |
| External switch keep hot facility | 40 | 40 | 40 | 40 | Not applicable | c. |
| Minimal DHW rpm | 25 | 25 | 25 | 20 | Adjustment range 25 to 50% | d |
| Min. Supply temperature during OT demand (OT= OpenTherm thermostat) | 40 | 40 | 40 | 40 | Adjustment range 10°C to 60°C | E |
| OT response | 1 | 1 | 1 | 1 | 0= ignore OT if < E 1= limit OT if < E 2= OT on-off | E. |
| Start rpm CH | 70 | 60 | 50 | 40 | Adjustment range 40 to 99% of the set maximum rpm | F |
| Start rpm DHW | 70 | 60 | 50 | 40 | Adjustment range 40 to 99% of the set maximum rpm | F. |

| | | | | | | |
|--|----|----|----|----|--|----|
| Max. fan rpm | 45 | 44 | 48 | 65 | Adjustment range: nominal value \pm 200 rpm. With this parameter the maximum rpm can be set. | H |
| Legionella prevention (only applicable when using external tank and W-plan) | 0 | 0 | 0 | 0 | 0 = Legionella prevention disabled. 1 = Legionella prevention weekly 2 = Legionella prevention daily | L |
| Set point CH (flow temperature) during heating external DHW tank | 85 | 85 | 85 | 85 | Adjustment range 60°C to 90°C | n |
| Keep hot temperature Eco/Comfort mode | 0 | 0 | 0 | 0 | Not applicable | n. |
| Delay time for responding on CH demand | 0 | 0 | 0 | 0 | Not applicable | O. |
| Waiting time after a DHW demand before a CH demand is answered | 0 | 0 | 0 | 0 | Adjustment range 0 to 15 minutes | o |
| Eco days | 3 | 3 | 3 | 3 | Not applicable | o. |
| Anti cycle time (Delay time reacting on CH demand after exceeding maximum setting CH temp.) | 5 | 5 | 5 | 5 | Adjustment range 0 to 15 minutes | P |
| Ref.value DHW | 0 | 0 | 0 | 0 | Not applicable | P. |
| Summer mode | 0 | 0 | 0 | 0 | Not applicable | q |
| Heating curve coefficient | 0 | 0 | 0 | 0 | Not applicable | r |

10.3.1 Enable/disable external boiler keep hot facility by Open Therm room thermostat or external switch

When using a W-plan it is possible to enable and disable the keep hot facility of the boiler by using an external switch or by the Open Therm room thermostat. For this the boiler needs to be set in Eco mode: (☺ LED on).

10.4 Weather-compensation adjustment

When an external sensor is connected the supply temperature is adjusted automatically depending on the outside temperature, in accordance with the heating line set.

The maximum supply temperature (Tmax) is set via the temperature display. If desired, the heating line can be changed in the parameter list. See § 10.3.

Heating line graph

X. Outside T in °C

Y. Supply T in °C

A. Factory setting

(Tmax CH = 80°C, Tmin CH=25°C, Tmin out=-7°C, Tmax out= 25°C)

B. Example

(Tmax CH = 60°C, Tmin CH=25°C, Tmin out=-7°C, Tmax out= 25°C)

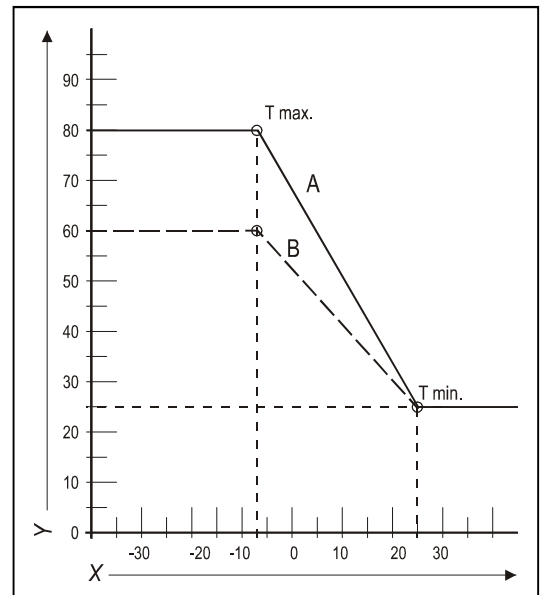

10.5 Setting maximum CH power

The maximum CH power is set at maximum (85%) in the factory. If less power is necessary for the CH installation, the maximum CH power can be changed by changing the fan rpm. See table Setting CH power.

This table shows the relationship between the fan rpm and the appliance power.

Setting CH power

| Desired CH power (in kW approx.) | | | | Setting on service display (in % of max. rpm) |
|----------------------------------|-------|-------|-------|---|
| 18 SB | 24 SB | 30 SB | 40 SB | |
| - | - | - | 40,9 | 99 |
| 17,8 | 22,8 | 26,3 | 34,8 | ± 83 |
| 14,8 | 19,1 | 22,6 | 28,5 | 70 |
| 12,7 | 16,4 | 19,0 | 24,5 | 60 |
| 10,6 | 13,7 | 15,8 | 20,5 | 50 |
| 8,3 | 11,0 | 12,7 | 16,4 | 40 |
| 6,4 | 8,3 | 8,5 | 12,3 | 30 |
| 5,4 | 6,9 | 7,1 | 10,2 | 25 |
| - | - | - | 7.8 | 20 |



NOTE

The power during burning is increased slowly and is reduced as soon as the set supply temperature is reached (modulate on T flow).

10.6 Adjusting pump setting

The switch for adjusting the pump setting is located on the CH pump connection box (Factory setting III).

- Adjust the pump setting dependent on the maximum power set and the water resistance of the installation by setting the parameters 3. (3 dot) and c. (c dot). The pump speed will now modulate between the minimum and maximum value proportional to the fan speed.
- Check the temperature difference between the appliance supply and return: this must be approximately 20°C. Make sure the flow does not undershoot the values mentioned in the table below.

| The minimum flow quantity (l/h) | Power setting (kW) |
|---------------------------------|--------------------|
| 155 | 5,4 |
| 510 | 17,8 |
| 650 | 22,8 |
| 750 | 26,3 |
| 1150 | 40,9 |

Appliance pressure loss graph, CH side

- A. Compact HRE 18 SB
- B. Compact HRE 24 SB
- C. Compact HRE 30 SB
- D.. Compact HRE 40 SB
- X Flow in l/h
- Y Pressure loss / water head in mH₂O

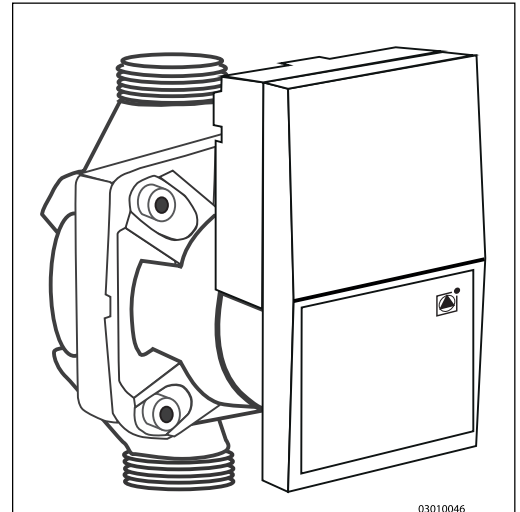

03010046

Wilo Yonos Para 15-7

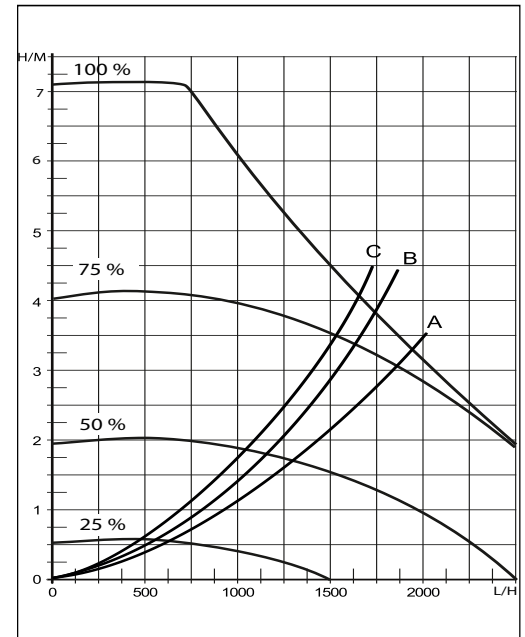

WILO Yonos Para 15-7,5

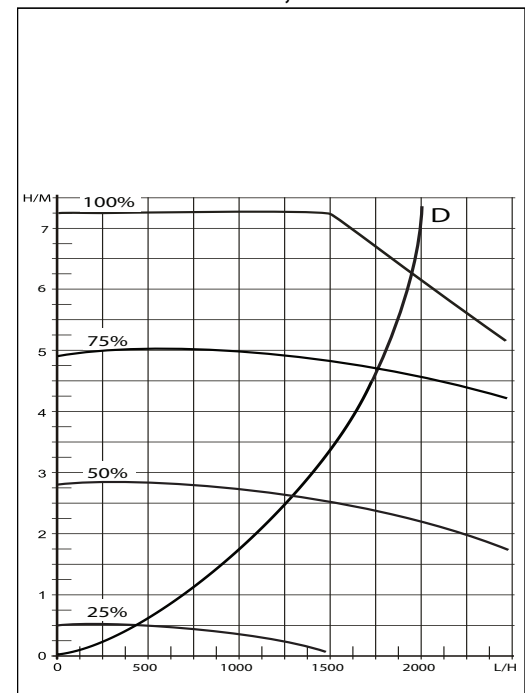

030701003

10.7 Gas-Air ratio control

The gas air ration control of the boiler is set to the correct value in the factory and does not need to be adjusted. The gas type of the boiler on which the boiler has been set is noted on the data plate. The boiler is only to be used in combination with this gas type.

When necessary the boiler can be converted to another gas type using the appropriate conversion set. See the table below for the correct gas ring.

Table 1, inserts and associated gas rings per boiler type.

| Model | Insert number | Gas category | |
|-------|---------------|-------------------------------|------------------------------|
| | | Natural gas G20 20 mBar | Propane 3P G31 37 mBar |
| | | Gas ring | |
| 18 SB | 471 | 505 | 410 |
| 24 SB | 406 | 600 | 480 |
| 30 SB | 362 | 655 | 525 |
| 40 SB | 362 | 655 | 525 |

The correct setting of the Gas-Air ratio can be checked by measuring the flue gases using a calibrated O₂ measuring device. The measurement must be performed first at maximum power and thereafter on the minimum power. (see § 10.8.1 and § 10.8.2). For reference reasons the tables below contain O₂ and CO₂ values.

When the CO₂ or O₂ value is incorrect only the setting on minimum power can be adjusted (see § 10.8.3) by changing the setting of the gas valve.



Important

- During the CO₂ or O₂ check the front casing of the boiler needs to be removed.
- The deviation of the O₂ analyser must be restricted to +/- 0.3%
- A reliable measurement is only guaranteed when no extreme vacuum in the flue pipe is present (i.e. draft due to hard wind).
- A deviation at maximum power can not be adjusted with the gas valve setting. When the value measured at maximum power is without the prescribed range the boiler has to be checked on gas tightness and usage of the correct components, in particular the gas ring and the fan.
- When replacing parts or converting the boiler to another gas type the correct functioning of the gas air ration always has to be checked.

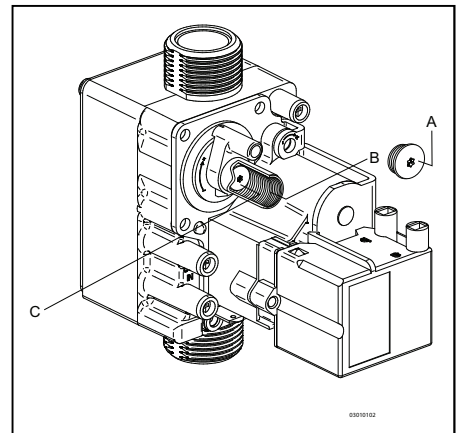
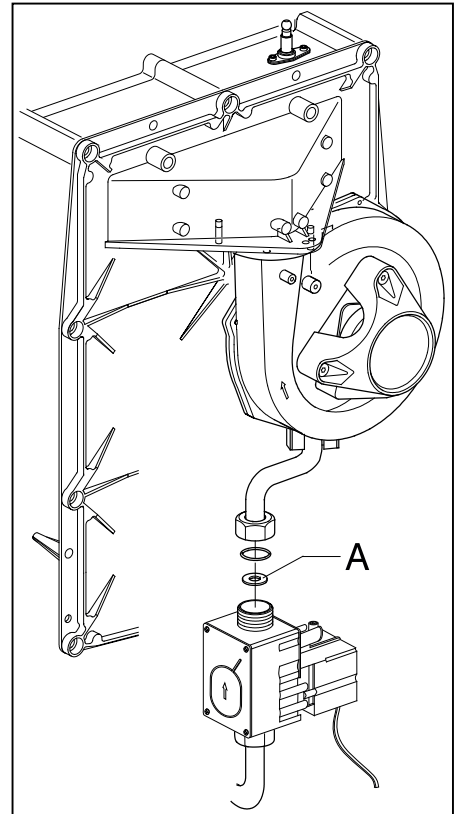

10.8 Checking the gas air ratio control

10.8.1 Checking flue gas at maximum power.

1. Switch the appliance off with the **⏻** button .
[-] will appear in service display.
2. Remove the front panel by untightening the 2 screws.
3. Remove the cap X of the flue gas sampling point on the adapter.
4. Position the measuring probe or the flue gas analyser into the sampling point.

Important



- Ensure yourself that the analyser start up procedure has been finalized before placing the probe.
- The probe needs to close the sampling point fully to ensure an accurate measurement
- The end (tip) of the probe must be completely in the flue gasses (in the middle of the flue pipe)

5. Switch the appliance on with the **⏻** button .
6. Activate the test program for maximum output by simultaneously pressing the buttons **⚙** and **+** twice. A capital **H** appears in service display.

Important



- Make sure a capital **H** is shown in the display to ensure the appliance to run at maximum power.

7. Wait until the reading of the flue gas analyser is stable (minimal 3 minutes)
8. Note the measured value $O_2(H)$ or $CO_2(H)$
 $O_2(H)$ = measured O_2 value at maximum power
 $CO_2(H)$ = Measured CO_2 value at maximum power
9. Check if the measured value is in accordance with the data noted in table 2a or 2b .

Table 2a: Limits $O_2(H)$ at maximum power (open casing)

| Limits | Gas category | |
|---------------|---------------------|-------------------|
| | Natural gas G 20 | Propane 3P G31 |
| | O_2 [%] | O_2 [%] |
| Maximum value | 5.60 | 6.05 |
| Minimum value | 3.85 | 4.50 |

Table 2b: Limits $CO_2(H)$ at maximum power (open casing)

| Limits | Gas category | |
|---------------|---------------------|-------------------|
| | Natural gas G 20 | Propane 3P G31 |
| | CO_2 [%] | CO_2 [%] |
| Maximum value | 9.6 | 10.8 |
| Minimum value | 8.6 | 9.8 |



Important

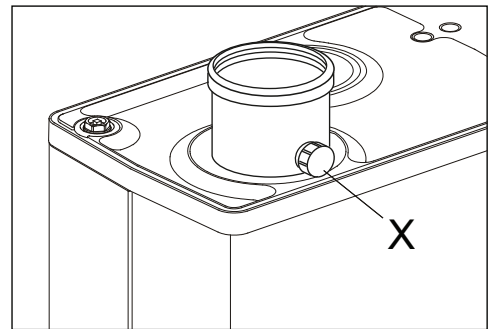
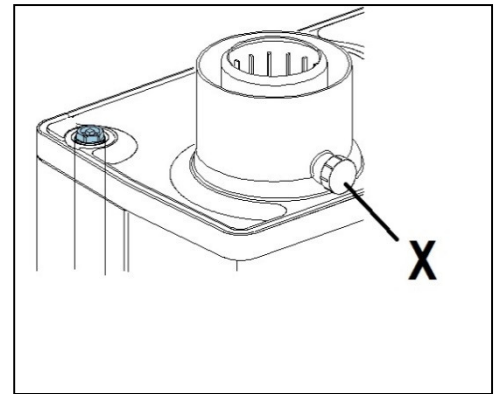
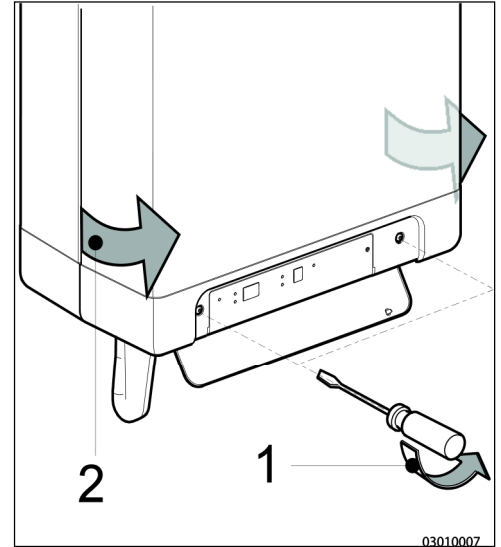

- A deviation at maximum power can not be adjusted with the gas valve setting. When the value measured at maximum power is without the prescribed range the boiler has to be checked on gas tightness and usage of the correct components, in particular the gas ring, the insert and the fan.

10. Proceed performing the measurement on minimum output (see § 10.8.2).



10.8.2 Checking flue gas at minimum output

Before measuring the flue gasses at minimum output the measurement of the maximum output must be completed. The measured O₂ or CO₂ value at maximum output is important for determining the correct value for the measurement at minimum output. See § 6.8.1 for measuring at maximum output

1. Activate the test program for maximum output by simultaneously pressing the buttons  and . A capital L appears in service display.
2. Wait until the reading of the analyser is stable (min. 3 minutes)
3. Note the measured value O₂(L) or CO₂(L).
O₂(L) = is the measured value of O₂ at minimum power
CO₂(L) = is the measured value of CO₂ at minimum power
4. Check if the measured value is in accordance to the data in table 3a or 3b



The O₂ lower limit is the value of O₂(H) noted during the measurement at maximum output .
The CO₂ upper limit is the value of CO₂(H) noted during the measurement at maximum output.
(See § 10.8.1)

Table 3a: limits O₂(L) at minimum output (open casing)

| Limits | Gas category | |
|---------------|--------------------|--------------------------|
| | Natural gas G20 | Propane 3P G31 |
| | O ₂ [%] | O ₂ [%] |
| Maximum value | 6.00 | 6.65 |
| Minimum value | O ₂ (H) | O ₂ (H) + 0.5 |

Table 3b: limits CO₂(L) at minimum output (open casing)

| Limits | Gas category | |
|---------------|---------------------|---------------------------|
| | Natural gas G20 | Propane 3P G31 |
| | CO ₂ [%] | CO ₂ [%] |
| Maximum value | CO ₂ (H) | CO ₂ (H) – 0.3 |
| Minimum value | 8.4 | 9.4 |







Important

- The gas-air ratio is set correctly when the measured value at minimum output is within the upper and lower limit. Adjusting the gas-air ratio is not advised.
- The gas-air ratio needs to be adjusted in accordance to § 10.8.3 when the measured value at minimum output is not within the upper and lower limit.





For example (Natural gas G20)

During maximum output a O₂(H) value of 4.0 % has been measured. In that case the O₂(L) value at minimum output must be in-between 4 % (= value O₂(H)) and 6.05% as stated in the table. When during minimum output a value out of this range is measured the gas-air ratio must be adjusted..

5. Proceed, in case of a deviating value by adjusting the gas valve in accordance to § 10.8.3. In case of a correct setting continue with point 6.
6. Fit the front panel to the appliance and tighten the 2 screws.
Check the values for CO at minimum output (= max. 160 ppm)
7. Activate the test program for maximum output by simultaneously pressing the button  and  twice.
A capital H appears in service display.
Check the values for CO at maximum output (= max. 160 ppm)
8. Switch the appliance off with the  button .
9. Remove the measuring probe of the flue gas analyser and replace the cap on the sampling point.
10. Check the tightness of the sampling point
11. Switch the appliance off with the  button and check that the appliance is functioning well.

10.8.3 Correction gas air ratio on minimum power

Before the correction of the gas air ratio on minimum output the measurement of the maximum output must be completed. The measured O₂ or CO₂ value at maximum output is important for determining the correct value for the measurement at minimum output. See § 10.8.1 and § 10.8.2 for measuring at maximum output.

1. Remove the cover cap (A) on the gas valve so setting screw B will become attainable.
2. Activate the test program for minimum output by simultaneously pressing the buttons  and . A capital L appears in service display.
3. Wait until the reading of the analyser is stable (min. 3 minutes).
4. Measure the O₂(L) or CO₂(L) value
5. Set, using adjustment screw B de correct value for O₂(L) or CO₂(L).
See table 5a or 5b for the correct value

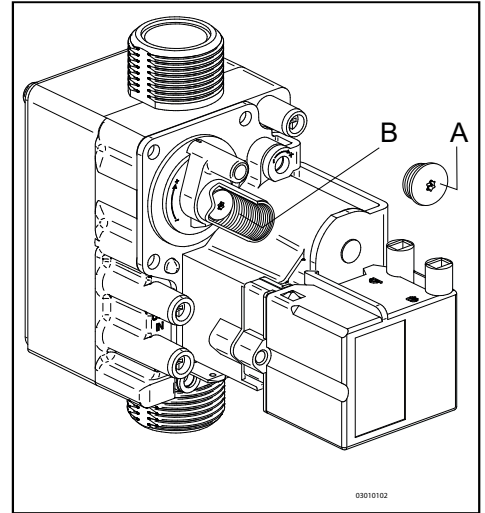

- Choose the correct table (4a and 5a is for natural gas, 4b and 5b is for Propane).
- The value measured at maximum output as noted during the measurement on maximum output (CO₂(H) or O₂(H))
Turning clockwise of the adjustment screw will raise the CO₂ value and lower the O₂ value. Turing anti clockwise will raise the O₂ value and lower the CO₂ value.
- Change the setting in small steps and wait until the reading is stable before continue.

Table 4a: Determining the correct setting of O₂ at minimum output for natural gas G20 (open casing)

| Natural gas G20 (20 mBar) | |
|---|---|
| Measured value am maximim power (See § 10.8.1) | Prescribed value at minimum power (= 0.5 x O ₂ (H) + 3.0) |
| O ₂ (H) [%] | O ₂ (L) [%] |
| 5.60 | 5.80 ±0.2 |
| 5.30 | 5.65 ±0.2 |
| 5.00 | 5.50 ±0.2 |
| 4.70 | 5.35 ±0.2 |
| 4.40 | 5.20 ±0.2 |
| 4.10 | 5.05 ±0.2 |
| 3.85 | 4.90 ±0.2 |

Table 4b: Determining the correct setting of O₂ at minimum output for propane G31 (open casing)

| Propane 3P G31 (37 mBar) | |
|---|---|
| Measured value am maximim power (See § 10.8.1) | Prescribed value at minimum power (= O ₂ (H) + 0.5) |
| O ₂ (H) [%] | O ₂ (L) [%] |
| 6.05 | 6.55 ±0.2 |
| 5.70 | 6.20 ±0.2 |
| 5.40 | 5.90 ±0.2 |
| 5.10 | 5.60 ±0.2 |
| 4.80 | 5.30 ±0.2 |
| 4.50 | 5.00 ±0.2 |

Table 5a: Determining the correct setting of CO₂ at minimum output for natural gas G20 (open casing)

| Natural gas G20 (20 mBar) | |
|---|--|
| Measured value at maximum power (See § 10.8.1) | Prescribed value at minimum power (= 0.5 x CO ₂ (H) + 4.2) |
| CO ₂ (H) [%] | CO ₂ (L) [%] |
| 9.6 | 9.0 ± 0.1 |
| 9.4 | 8.9 ± 0.1 |
| 9.2 | 8.8 ± 0.1 |
| 9.0 | 8.7 ± 0.1 |
| 8.8 | 8.6 ± 0.1 |
| 8.6 | 8.5 ± 0.1 |

Table 5b: Determining the correct setting of CO₂ at minimum output for Propane G31 (open casing)

| Propane 3P G31 (37 mBar) | |
|---|--|
| Measured value at maximum power (See § 10.8.1) | Prescribed value at minimum power (= CO ₂ (H) - 0.3) |
| CO ₂ (H) [%] | CO ₂ (L) [%] |
| 10.8 | 10.5 ± 0.1 |
| 10.6 | 10.3 ± 0.1 |
| 10.4 | 10.1 ± 0.1 |
| 10.2 | 9.9 ± 0.1 |
| 10.0 | 9.7 ± 0.1 |
| 9.8 | 9.5 ± 0.1 |

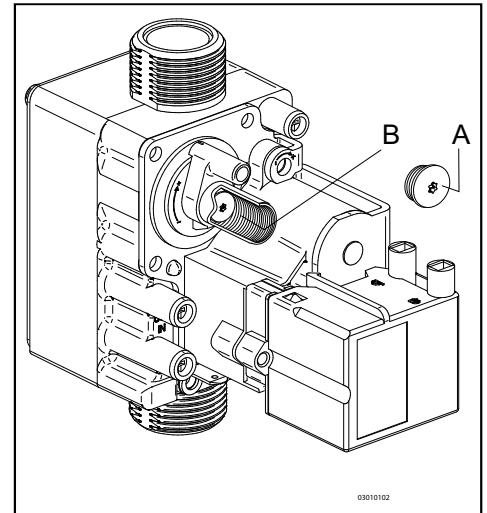

Example (when using natural gas G20)

During the measurement at maximum output the value of O₂(H) was 4.1 %.
The setting for O₂(L) at minimum output will then be 5.05 ± 0,2 %

1. Replace the cap A of the adjustment screw B for protection
2. Repeat the measurement at maximum and minimum output (§ 1.2.1 en § 1.2.2) to ensure the correct operation of the boiler.



Important

Work on gas carrying parts may only be carried out by a qualified competent person.

10.9 Conversion to different gas type



CAUTION

Work on gas carrying parts may only be carried out by a qualified competent person.

If a different type of gas is connected to the appliance than that for which the appliance has been set by the manufacturer, the gas metering ring should be replaced. Conversion sets for other types of gas are available to order.

10.9.1 Converting to L.P.G

1. Switch the boiler off and isolate the boiler from the mains power.
2. Close the gas tap.
3. Remove the front panel from the appliance.
4. Unscrew the coupling (A) above the gas valve and twist the gas mixing tube towards the rear (B).
5. Replace the O-ring (C) and the gas restriction (D) with the rings from the conversion set.(5.05 for 18SB. 5.50 for 24,30,and 40SB)
6. Re-assemble in reverse sequence.
7. Open the gas tap.
8. Check the gas connections before the gas valve for gas-tightness.
9. Switch on the mains power.
10. Check the gas connections after the gas valve for gas-tightness (during operation).
11. Now check the setting of the CO₂ percentage at high setting (H in display) and low setting (L in display).



CAUTION

It is not possible to adjust the CO₂ percentage at high setting. When the CO₂ percentage at high setting is not within the prescribed tolerance band please contact Intergas Heating.

For adjusting CO₂ percentage at low setting see § 10.8.2.

Place a sticker for the gas type set over the existing sticker next to the gas valve.
Place a sticker for the gas type set next to the identification plate.

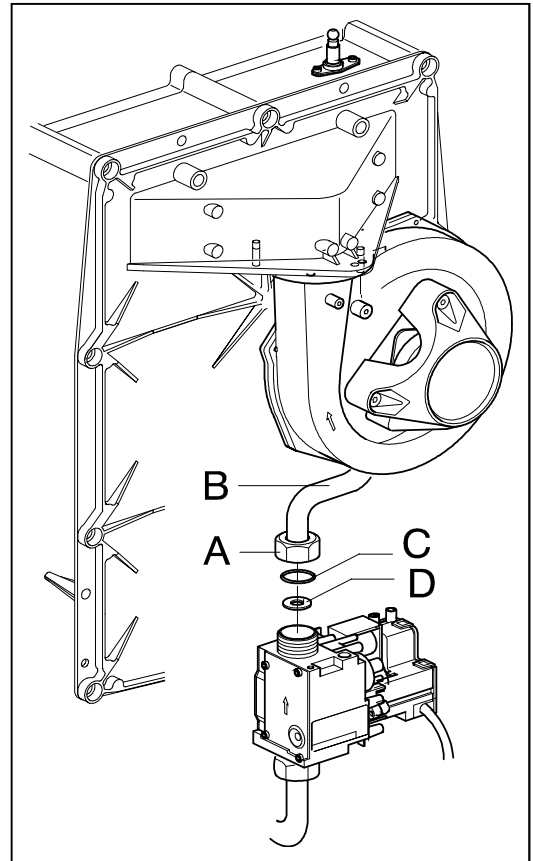

11 FAULTS

11.1 Fault codes

If the fault LED is flashing, the boiler controller has detected a fault. A fault code will be indicated on the temperature display. Once the fault has been rectified the boiler controller can be restarted.

Press the reset  key on the operating panel.

The following faults are distinguished

| Temperature display | Display Fault | Possible Solution |
|---------------------|--|--|
| 10, 11, 12, 13, 14 | Sensor fault S1 Flow switch does not disconnect | <ul style="list-style-type: none"> • Check wiring for break • Replace S1 • Check flow switch |
| 20, 21, 22, 23, 24 | Sensor fault S2 | <ul style="list-style-type: none"> • Check wiring for break • Replace S2 |
| 0 | Sensor fault after self check | <ul style="list-style-type: none"> • Replace S1 and/or S2 |
| 1 | Temperature too high | <ul style="list-style-type: none"> • Air in installation • Pump not running • Unsufficient flow in installation, radiators closed, pump setting too low • Flow switch sticking |
| 2 | S1 and S2 interchanged | <ul style="list-style-type: none"> • Check cable loom • Replace S1 or S2 |
| 4 | No flame signal | <ul style="list-style-type: none"> • Gas tap closed • No or incorrect ignition gap • Gas supply pressure too low or failing • Gas valve or ignition unit not powered |
| 5 | Poor flame signal | <ul style="list-style-type: none"> • Condensate drain blocked • Check adjustment of gas valve |
| 6 | Flame detection fault | <ul style="list-style-type: none"> • Replace ignition cable + spark plug cap • Replace ignition unit • Replace boiler controller |
| 8 | Incorrect fan speed | <ul style="list-style-type: none"> • Fan catching on casing • Wiring between fan and casing • Check wiring for poor wire contact • Replace fan* |
| 29,30 | Gas valve relay faulty | <ul style="list-style-type: none"> • Replace boiler controller |



CAUTION

Always use original Intergas spare parts when replacing components.

Failure to fit the sensors S1 and/or S2, or to fit them correctly can result in serious damage.



CAUTION

* The boiler is equipped with a non-return valve (A), positioned above the fan. Check that the valve is still in good condition and ensure the non-return valve is repositioned correctly when replacing the fan.

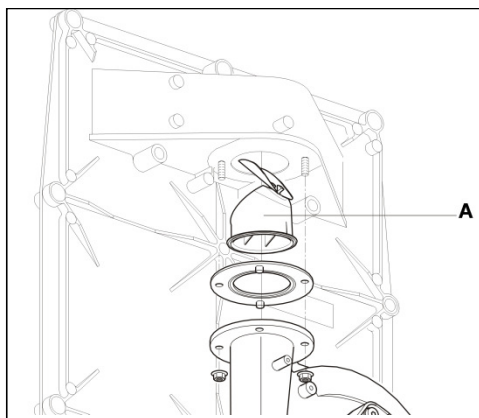

11.2 Other faults

11.2.1 Burner does not ignite

Possible causes:

Gas tap is closed.

➔ Solution:
Open gas tap.

No ↓

Air in the gas pipe.

➔ Remove air form gas pipe.

No ↓

Gas supply pressure to low.

➔ Contact the gas supply company.

No ↓

No ignition.

➔ Replace ignition electrode.

No ↓

No spark. Ignition unit on gas valve faulty.

➔ Check the cabling. Check the spark plug cap. Replace the ignition unit.

No ↓

Gas/air adjustment not correctly set.

➔ Check adjustment. See gas/air adjustment.

No ↓

Fan faulty.

➔ Check the wiring. Check the fuse , if necessary, replace the fan.

No ↓

Fan dirty.

➔ Clean the fan.

No ↓

Gas valve faulty.

➔ Replace the gas valve. Re-adjust the gas valve, see gas/air adjustment.

11.2.2 Burner ignites noisily

Possible causes:

Gas supply pressure to high.

➔ Solution:
The house pressure switch may be faulty. Contact the gas company.

No ↓

Incorrect ignition gap.

➔ Replace the ignition pin.
Check the ignition electrode gap.

No ↓

Gas/air adjustment not correctly set.

➔ Check the setting. See gas/air adjustment.

No ↓

Weak spark.

➔ Check the ignition gap.
Replace the ignition electrode.
Replace the ignition unit on the gas valve.

Checking ignition pin position using test tool

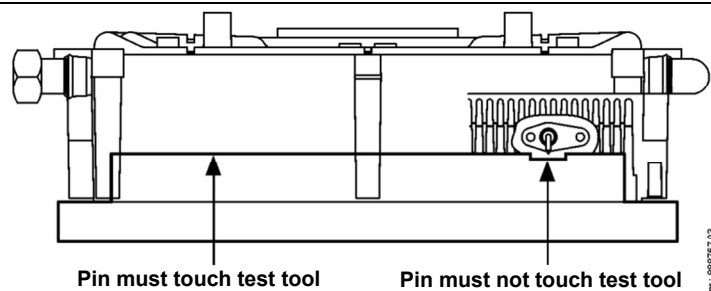

11.2.3 Burner resonating

Possible causes:

Gas supply pressure too low.

➔ Solution:
The house pressure switch may be faulty. Contact the gas company.

No ↓

Recirculation of combustion gasses.

➔ Check the gas flue an the air supply.

No ↓

Gas/air adjustment not correctly set.

➔ Check the setting, see gas/air adjustment.

11.2.4

11.2.5 No heating (CH)

Possible causes:

Room thermostat / weather-dependent adjustment not closed or faulty.

No ↓

No current (24 V).

No ↓

Pump not running.

No ↓

Burner not firing on CH: sensor S1 or S2 faulty.

No ↓

Burner does not ignite.

Solution:

Check the wiring.
Replace the thermostat.
Replace the weather-dependant adjustment.

Check the wiring against the diagram.
Check the connector X4.
Replace the faulty manager.

Check the power supply.
Check connector X2.
Replace faulty pump.

Replace sensor S1 or S2. See fault code.

See burner does not ignite.

11.2.6 The power is reduced

Possible causes:

At high rpm the power has fallen by more than 5%.

Solution:

Check appliance and flue system for fouling.
Clean the appliance and flue system.

11.2.7 CH does not reach temperature

Possible causes:

Room thermostat setting incorrect.

No ↓

Temperature is too low.

No ↓

Pump not running correctly. Pump setting is too low.

No ↓

No circulation in the installation.

No ↓

The boiler power has not been correctly set for the installation.

No ↓

No heat transfer as a result of lime scale or fouling in the heat exchanger.

Solution:

Check the setting and if necessary adjust: Set to 0.1A.

Increase the CH temperature. See Operating CH . Check outside sensor for short-circuiting. Rectify.

Increase pump setting, or replace the pump.

Check whether there is circulation: at least 2 or 3 radiators must be open.

Adjust the power. See setting maximum CH power.

De-scale or flush the heat exchanger on the CH side.

11.2.8 No hot water (only when an indirectly heated DHW storage cylinder is applied)

Possible causes:

No current at the diverter valve.

No ↓

Diverter valve does not switch.

No ↓

No current at the DHW storage cylinder sensor/thermostat.

No ↓

Burner does not ignite on DHW: DHW storage cylinder sensor/thermostat defect.

No ↓

Burner does not ignite.

Solution:

Check the wiring according to the diagram.

Replace diverter valve.

Check the wiring according to the diagram.

Replace DHW storage cylinder sensor/thermostat.

See burner does not ignite.

11.2.9 Hot water does not reach temperature (only when an indirectly heated DHW storage cylinder is applied)

Temperature setting for DHW storage cylinder too low.



Solution:

Set the DHW storage cylinder temperature. See 10 Setting and adjustment.

11.2.10 LED on CH pump is flashing alternately red and green.

Possible causes:

Mains voltage too high or too low.



Solution:

Check the mains.

No ↓

Temperature of the pump is too high



Check the water and environment temperature.

11.2.11 LED on CH pump is flashing red.

Possible causes:

Pump is not running



Solution:

Reset the boiler by shutting of the boiler (stand-by or powerless) for at least 20 seconds.

Note: If the pump is set on "continuously active" (parameter 2 = 1) the boiler must be made powerless for at least 20 seconds.

12 MAINTENANCE

The appliance and the installation should be checked and if necessary cleaned every year by a registered expert.

For assembly and disassembly the following tools can be used:

1. Cross head screwdriver
2. Allen key 8 mm
3. Fork spanner 30 mm

After servicing, complete the relevant Benchmark Service Record section located on page 51 of this document.



CAUTION

Work on gas carrying parts may only be carried out by an authorised installer.

When the appliance has just been operating parts may be hot.



CAUTION

The integrated insulation and burner seal contain ceramic fibres.

12.1 Disassembly

1. Switch the boiler off and isolate the boiler from the mains power.
2. Close the gas tap.
3. Open the display cover and turn the two screws on the left- and right-hand side of the display and remove the front panel.
4. Wait until the appliance has cooled down.
5. Unscrew the coupling nut at the base of the flue pipe anti-clockwise.
6. Slide the flue pipe upwards (1) turning it anti-clockwise until the bottom of the pipe is above the condensate drain pan connection. Pull the bottom of the pipe forwards (2) and remove the pipe downwards (3) turning it anti-clockwise.
7. Lift the condensate drain pan on the left-hand side from the connection to the condensate trap (4) and turn it to the right with the condensate trap connection over the edge of the base tray (5). Push the back of the condensate drain pan downward from the connection to the heat exchanger (6) and remove it from the appliance.
8. Remove the connector from the fan and the ignition unit from the gas valve.
9. Unscrew the coupling below the gas valve.
10. Unscrew the shoulder bolts from the front cover and remove this complete with gas valve and fan to the front (NB: ensure that the burner, insulation plate, gas valve, gas supply and fan do not get damaged).

Note

When the appliance is connected to a wall mounting jig with built-in expansion vessel a regular inspection of the expansion vessel pressure is advisable. Access to re-pressurise the expansion vessel is at the rear back of the vessel.



CAUTION

The boiler is equipped with a non-return valve (A), positioned above the fan. Check that the valve is still in good condition and ensure the non-return valve is repositioned correctly when replacing the fan.

12.2 Cleaning

1. Clean the heat exchanger from top to bottom with a plastic brush or compressed air.
2. Clean the underside of the heat exchanger.
3. Clean the condensate drain pan with water.
4. Clean the condensate trap with water.

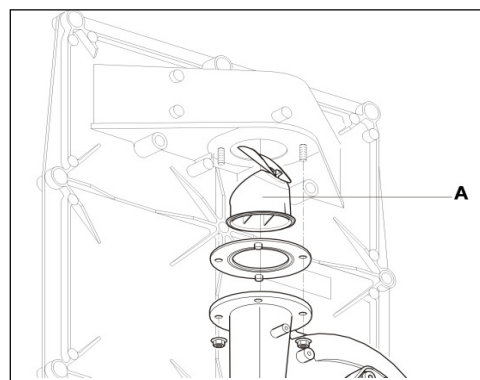
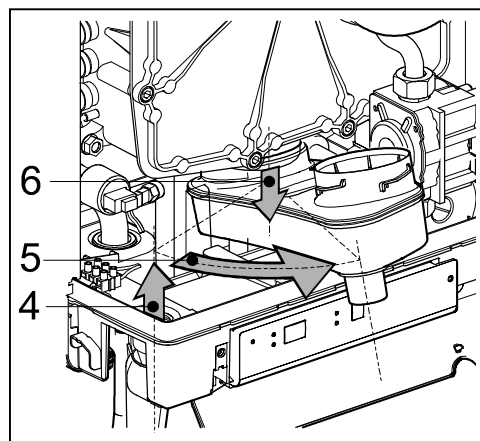
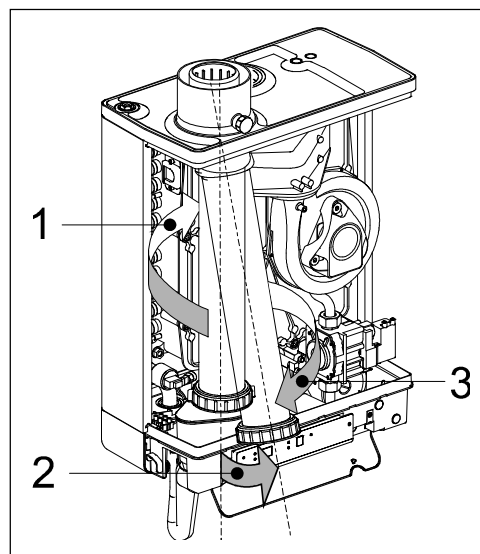
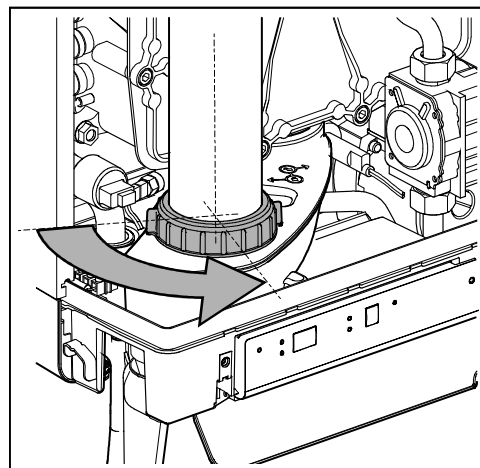

12.3 Assembly



CAUTION

It is recommended that the front plate seal is replaced every time the front plate is removed from the heat exchanger.

When fitting the remaining seals check for damage, hardening, tears or hairline tears and/or discoloration. Where necessary fit a new seal. Also check whether seals are still correctly positioned.

Warranty will be void by not correctly replacing removed parts!

1. Check if there is a small layer of ceramic grease on the contact surface between the shoulder bolt and the front plate.
2. Ensure that the seal around the front cover is installed correctly. Place the front cover on the heat exchanger and secure it using the socket head screws plus serrated lock washers. Tighten the shoulder bolts equally hand-tight (10 – 12 Nm), working crosswise. See the picture for the correct sequence.
N.B. The picture is showing a front plate with 11 shoulder bolts (Kompakt HRE 24 SB, HRE 30 SB or HRE 40 SB). The front plate for the Kompakt HRE 18 SB has 9 shoulder bolts.
3. Fit the gas connection below the gas valve.
4. Fit the connector to the fan and the ignition unit to the gas valve.
5. Fit the condensate drain by sliding on to the exchanger outlet stump (1) with the condensate trap connection still in front of the base tray. Then turn it to the left (2) and push it downwards into the condensate trap connection (3). Make sure in doing this that the back of the condensate drain pan comes to rest on the lug at the back of the base tray (A).
6. Fill the condensate trap with water and fit it to the connection below the condensate drain pan.
7. Slide the flue pipe, turning it anti-clockwise, with the top around the flue adapter, into the top cover. Insert the bottom into the condensate drain pan and tighten the coupling nut clockwise.
8. Open the gas tap and check the gas connections below the gas valve and on the mounting bracket for leakage.
9. Check the CH and, if applicable, the water pipes for leakage.
10. Switch on the mains power and switch the appliance on with the **ⓘ** key.
11. Check the front cover, the fan connection on the front cover and the flue pipe components for leakage.
12. Check the gas/air adjustment.
13. Fit the casing, tighten the two screws left and right of the display and close the display cover.
14. Check the heating and, if applicable, the hot water supply.

12.4 Combustion

During routine servicing, and after any maintenance or change of part of the combustion circuit the following must be checked:

- The integrity of the flue system and the flue seals, as described in § 8.5 and the British Standards codes of practices, specifically BS 5440.
- The integrity of the boiler combustion circuit and the relevant seals, as described in § 12.3.
- The operational (working) gas inlet pressure at maximum rate, as described in § 10.7.2.
- The combustion performance, as described in § 10.7. and § 10.8.

BS 6798: 2009 Specification for installation and maintenance of gas-fired boilers of rated input not exceeding 70 kW net advises that:

- The person carrying out a combustion measurement should have been assessed as competent in the use of a flue gas analyser and the interpretation of the results;
- The flue gas analyser used should be one meeting the requirements of BS7927 or BS-EN50379-3 and be calibrated in accordance with the analyser manufacturers' requirements, and
- Competence can be demonstrated by satisfactory completion of the CPA1 ACS assessment, which covers the use of electronic portable combustion gas analysers in accordance with BS7967, Parts 1 to 4.

Connect the flue gas analyser to the flue gas sampling point (X) and check combustion as described in § 10.7. If the CO₂ percentage reading of the combustion gases at low setting falls into the bandwidth stated in § 10.7 the combustion setting is correct and no further adjustment is needed. If the combustion reading falls outside the prescribed tolerance band and the integrity of the complete flue system and combustion circuit seals have been verified as well as the inlet gas pressure proceed to adjust the gas/air ratio as described in § 10.8. When the CO₂ percentage at high setting is not within the prescribed tolerance band please contact Intergas Heating.

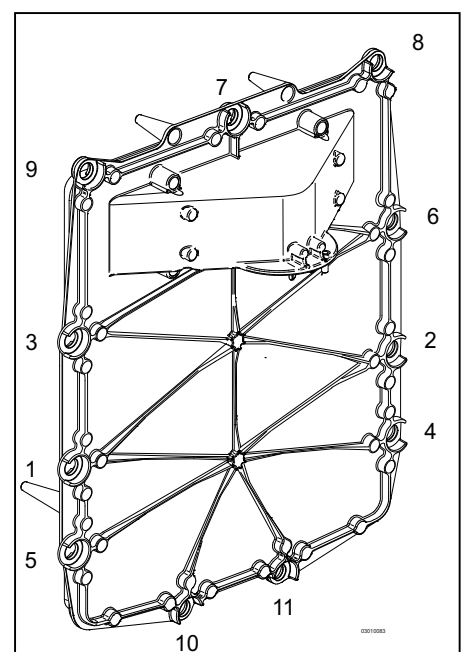
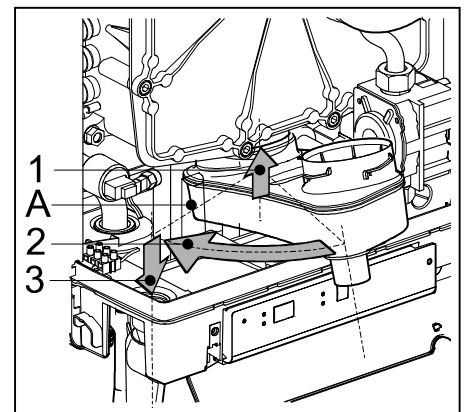
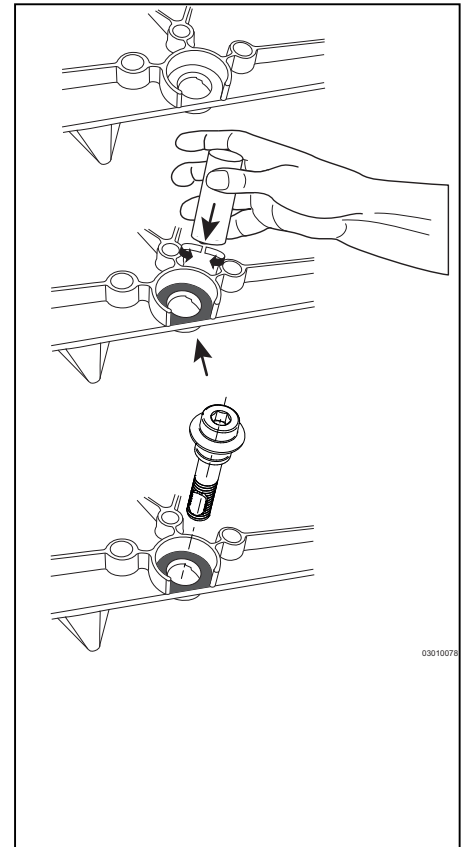

13 ELECTRICAL DIAGRAM

13.1 Electrical diagram HRE SB

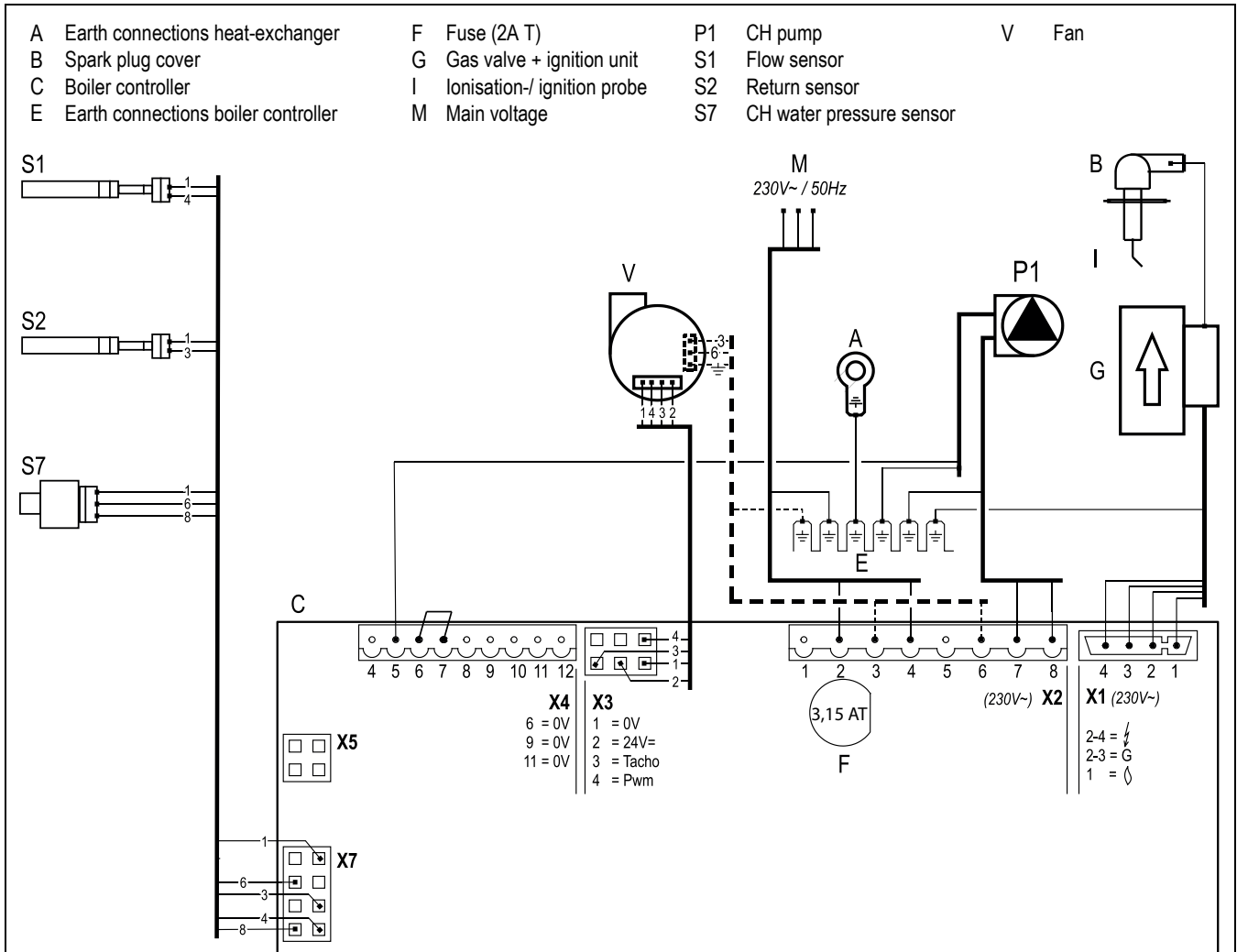

| | | | |
|------------------------------|-------|--|---|
| Connector X4 24V= | 6-7 | | On/off room thermostat (0,1A-24Vdc) and/or frost thermostat (remove connection 6-7) |
| | 8-9 | | External sensor (12k ohm / 25°C) |
| | 11-12 | | OpenTherm thermostat (remove connection 6-7) |
| Connector X2 230V~ | 1-3 | | Room thermostat 230 AC (1=Switch live, 3=Live(fused)) |
| | 1-3 | | Frost thermostat 230 AC (1=Switch live, 3=Live(fused)) |
| | 3-6 | | Power supply (230 V) fan |
| | 2-4 | | Mains (2=Live (brown), 4=Neutral (blue)) |
| | 7-8 | | CH-pump (8=L (brown), 7=N (blue)) |
| Connector X5 | | | Computer interface |

13.2 NTC resistances

| NTC 12kOhm | | | | | |
|------------|--------|--------|--------|--------|--------|
| T [°C] | R[ohm] | T [°C] | R[ohm] | T [°C] | R[ohm] |
| -15 | 76020 | 25 | 12000 | 65 | 2752 |
| -10 | 58880 | 30 | 9805 | 70 | 2337 |
| -5 | 45950 | 35 | 8055 | 75 | 1994 |
| 0 | 36130 | 40 | 6653 | 80 | 1707 |
| 5 | 28600 | 45 | 5522 | 85 | 1467 |
| 10 | 22800 | 50 | 4609 | 90 | 1266 |
| 15 | 18300 | 55 | 3863 | 95 | 1096 |
| 20 | 14770 | 60 | 3253 | 100 | 952 |

13.3 Typical Y Plan connection

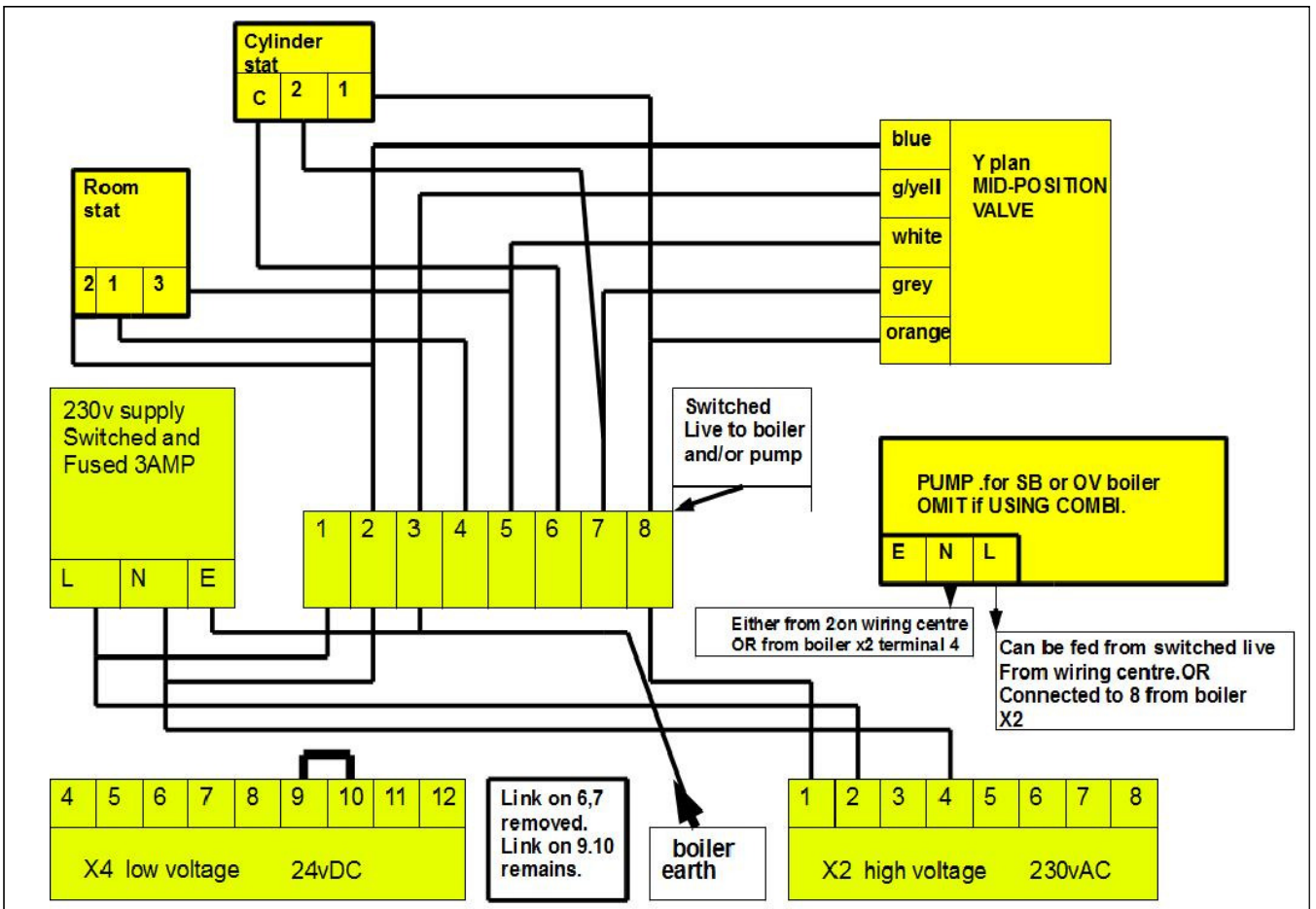

13.4 Typical S Plan connection.

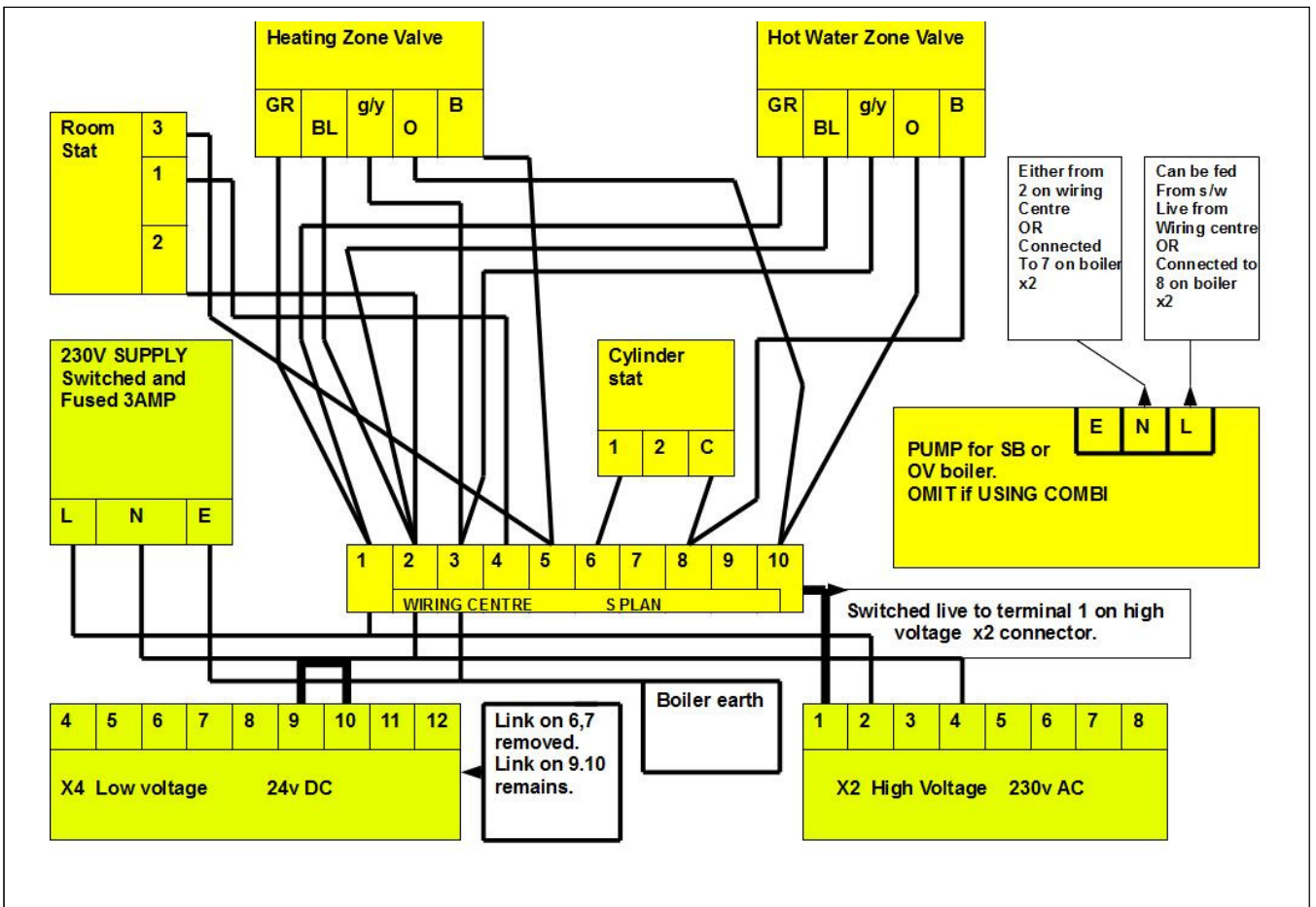

14 SHORT SPARES LIST

| Description | Article number |
|--|----------------|
| Fan 24 V, HRE 18 SB, 24 SB & 30 SB | 074507 |
| Fan 230 V, HRE 40 SB | 074577 |
| Fixing strip | 145308 |
| Temperature sensor (heat exchanger S1 & S2) | 200117 |
| Temperature sensor (DHW) | 200127 |
| CH Pump HRE 24/18, 28/24 & 36/30 (Wilo Yonos Para RS15-7) | 210337 |
| CH Pump HRE 36/40 (Wilo Yonos Para RS15-7,5) | 210367 |
| Ignition / ionisation electrode | 209327 |
| Ignition cable | 074607 |
| Gas valve Siemens | 801467 |
| Ignition module | 801477 |
| Condensate trap HRE 18 SB, 24 SB & 30 SB | 844187 |
| Condensate trap HRE 40 SB | 844787 |
| Flow switch (DHW) | 844267 |
| Condensate collector | 847037 |
| Pressure sensor (CH) | 864087 |
| Seal gas valve (inlet) | 875757 |
| O-ring gas restriction ring | 875827 |
| O-ring front plate Combi Compact HRE 36/30 & HRE 36/40 | 876597 |
| O-ring front plate Combi Compact HRE 28/24 | 877927 |
| O-ring front plate Combi Compact HRE 24/18 | 876467 |
| Seal ring condensate collector (heat exchanger connection) | 878147 |
| O-ring flue pipe dia 68*4 | 878537 |
| Seal ring flue pipe (outlet side) | 878547 |
| Condensate trap connection | 878577 |
| Sampling cap | 847000 |

15 WARRANTY CONDITIONS

With due regard for the conditions indicated below, Intergas Heating Ltd warrants to the authorised installer the soundness of the materials used in and the correct operation of its Central Heating products, when used for the purpose for which they are delivered. As the occasion arises we should be enabled to ascertain, on site if necessary, the soundness of the warranty entitlement.

The warranty comprises:

The warranty is limited to the free-of-charge resupply of parts that during the warranty period, entirely in our judgement exhibit material or manufacturing faults that are not the result of normal wear etc. Such parts should be sent to us carriage paid together with an indication of the defect and after replacement become our property.

1. The warranty period on parts is 2 years calculated from the date of installation. The extended warranty period on parts is 3 years calculated from the date of installation. The extended warranty is effective only if the annex to the warranty certificate has been signed by the purchaser and returned to us within 8 days of the date of installation.
2. The warranty period on the water tightness of the boiler's heat exchanger is 10 years, provided however that if, as a result of corrosion, leakages arise which in our view cannot be rectified on site, we will exclusively supply that boiler part on the basis of old for new, calculated at the time of replacement from the installation date.
3. The warranty ceases to apply if it is ascertained that the defects, damage or excessive wear are attributable to improper use or injudicious treatment or inexpert repair, setting, installation or maintenance by unauthorised installers or to the product being exposed to substances containing aggressive chemicals (including hair lacquer) and other harmful substances.
4. The warranty also ceases to apply if pipes and couplings have been used in the installation which can cause oxygen diffusion, or if the defect is the result of depositing of boiler scale (harmful to the boiler and the installation). Surface damage and transport damage are not covered by the warranty. The right to warranty ceases to apply if it cannot be demonstrated that, after commencement of use, the central heating boiler has been serviced at least once a year by an installer authorised for that purpose by or on behalf of the gas company. The instructions for installation and use which we issue for the boilers concerned should be complied with in full.
5. The manufacturer's liability under the agreement is expressly limited to fulfilment of the warranty obligations defined in this article. All claims for compensation, except for those relating to failure to fulfil the warranty obligations, are excluded. With due regard for the mandatory provisions regarding product or other liability, no rights may ever be derived at any time with regard to any consequential loss, loss of net worth or any loss whatsoever that might arise from defects in materials delivered or work performed by the manufacturer. In addition, all offers and agreements concerning deliveries and/or services to be made or provided by us are governed by the Conditions of Sale.

A copy of these conditions will be sent to you free of charge on request. Conditions to the contrary are expressly rejected. Furthermore all offers of and agreements regarding products to be supplied and/or services to be provided by us are subject to the general conditions of sales. A copy of these conditions will be sent free of charge on request. Other conditions are expressly rejected.

6. The warranty is effective only if the annex to this warranty certificate has been signed by the purchaser and returned to us within 8 days of the date of installation. By signing the warranty card the purchaser states his/her agreement that the items have been delivered in good condition.
7. If the installer's business has been terminated before the end of the warranty period, the user may invoke our warranty obligations to the installer.



Installers are required to carry out installation, commissioning and servicing work in accordance with the Benchmark Code of Practice which is available from the Heating and Hotwater Industry Council who manage and promote the scheme. Visit www.centralheating.co.uk for more information.

Use as intended

The appliance, as described in this documentation, is intended for heating rooms via a central heating installation and/or for supplying hot water. Any other use lies outside the intended use of the appliance. No liability can be accepted for loss or damage arising from incorrect use.

16 CE DECLARATION

Declaration of conformity in accordance with ISO IEC GUIDE 22.

| | |
|--------------|---|
| Manufacturer | Intergas Heating Ltd |
| Address | Building 94, Bay 1 Vantage Point The Pensnett Estate Kingswinford West Midlands DY6 7FS |

Hereby declares that the CH appliances:

Compact HRE 40 SB
Compact HRE 30 SB
Compact HRE 24 SB
Compact HRE 18 SB

meets the provisions of the following directives:

- Low Voltage Directive (2006/95/EC)
- Gas Appliances Directive (2009/142/EEC)
- Boiler Efficiency Directive for new oil- and gas-fired central heating boilers (92/42/EEC)
- EMC Directive (2004/108/EC)
- Ecodesign (2009/125/EG)
- Energy labelling 2010/30/EU

H. Bosscher, July 2015

17 GAS BOILER SYSTEM COMMISSIONING CHECKLIST

GAS BOILER SYSTEM COMMISSIONING CHECKLIST

This Commissioning Checklist is to be completed in full by the competent person who commissioned the boiler as a means of demonstrating compliance with the appropriate Building Regulations and then handed to the customer to keep for future reference.

Failure to install and commission according to the manufacturer's instructions and complete this Benchmark Commissioning Checklist will invalidate the warranty. This does not affect the customer's statutory rights.

| | | | |
|--|---|---------------------------------------|---|
| Customer name: | | Telephone number: | |
| Address: | | | |
| Boiler make and model: | | | |
| Boiler serial number: | | | |
| Commissioned by (PRINT NAME): | | Gas Safe register number: | |
| Company name: | | Telephone number: | |
| Company address: | | | |
| | | Commissioning date: | |
| To be completed by the customer on receipt of a Building Regulations Compliance Certificate* | | | |
| Building Regulations Notification Number (if applicable): | | | |
| CONTROLS (tick the appropriate boxes) | | | |
| Time and temperature control to heating | Room thermostat and programmer/timer Load/weather compensation | | Programmable room thermostat Optimum start control |
| Time and temperature control to hot water | Cylinder thermostat and programmer/timer | | Combination Boiler |
| Heating zone valves | Fitted | | Not required |
| Hot water zone valves | Fitted | | Not required |
| Thermostatic radiator valves | Fitted | | Not required |
| Automatic bypass to system | Fitted | | Not required |
| Boiler interlock | | | Provided |
| ALL SYSTEMS | | | |
| The system has been flushed and cleaned in accordance with BS7593 and boiler manufacturer's instructions | | | Yes |
| What system cleaner was used? | | | |
| What inhibitor was used? | | | Quantity litres |
| Has a primary water system filter been installed? | | | Yes No |
| CENTRAL HEATING MODE measure and record: | | | |
| Gas rate | m ³ /hr | OR | ft ³ /hr |
| Burner operating pressure (if applicable) | mbar | OR Gas inlet pressure | mbar |
| Central heating flow temperature | | | °C |
| Central heating return temperature | | | °C |
| COMBINATION BOILERS ONLY | | | |
| Is the installation in a hard water area (above 200ppm)? | | | Yes No |
| If yes, and if required by the manufacturer, has a water scale reducer been fitted? | | | Yes No |
| What type of scale reducer has been fitted? | | | |
| DOMESTIC HOT WATER MODE Measure and Record: | | | |
| Gas rate | m ³ /hr | OR | ft ³ /hr |
| Burner operating pressure (at maximum rate) | mbar | OR Gas inlet pressure at maximum rate | mbar |
| Cold water inlet temperature | | | °C |
| Hot water has been checked at all outlets | Yes | Temperature | °C |
| Water flow rate | | | l/min |
| CONDENSING BOILERS ONLY | | | |
| The condensate drain has been installed in accordance with the manufacturer's instructions and/or BS5546/BS6798 | | | Yes |
| ALL INSTALLATIONS | | | |
| Record the following: | At max. rate: | CO | ppm AND CO/CO ₂ Ratio |
| | At min. rate: (where possible) | CO | ppm AND CO/CO ₂ Ratio |
| The heating and hot water system complies with the appropriate Building Regulations | | | Yes |
| The boiler and associated products have been installed and commissioned in accordance with the manufacturer's instructions | | | Yes |
| The operation of the boiler and system controls have been demonstrated to and understood by the customer | | | Yes |
| The manufacturer's literature, including Benchmark Checklist and Service Record, has been explained and left with the customer | | | Yes |
| Commissioning Engineer's Signature | | | |
| Customer's Signature | | | |
| (To confirm satisfactory demonstration and receipt of manufacturer's literature) | | | |

*All installations in England and Wales must be notified to Local Authority Building Control (LABC) either directly or through a Competent Persons Scheme. A Building Regulations Compliance Certificate will then be issued to the customer.



Intergas boilers are manufactured in a Kiwa ISO 9001 certified production facility.



Intergas Heating Ltd

Intergas Heating Ltd
Building 94, Bay 1 Vantage Point
The Pensnett Estate
Kingswinford
West Midlands
DY6 7FS

Tel: 01527 888000
Fax: 01384 279480
info@intergasheating.co.uk
www.intergasheating.co.uk

88322802

