

GEOMIL PANTHER 170 CPT CRAWLER DATASHEET

Cone Penetration Tests (CPT) are carried out using twenty tonne capacity hydraulic penetrometer equipment mounted on ballasted vehicles. SOCOTEC UK is accredited by the United Kingdom Accreditation Service (UKAS) to undertake electric friction and piezocone testing as detailed in its UKAS schedule, Laboratory No 0001.

All CPT vehicles are fitted with a computerised logging system which displays a continuous graphical record of the measured data against depth. Data plots can be produced and supplied to the Client in the field upon completion of the testing.

TRACK MOUNTED PENETROMETER

- ▶ Steel track mounted unit with enclosed cab and CPT rig
- ▶ Ideal for soft and/or waterlogged ground with a low ground bearing pressure of 50kPa (7.5 psi)
- ▶ 200kN CPT pushing platform
- ▶ Maximum depth of penetration 40m dependant on ground conditions
- ▶ Production rate of up to 150m per day



Contact: salesuk@socotec.com

GEOMIL PANTHER 170 CPT CRAWLER DATASHEET

When being tracked	
Length	6.00m
Width	2.50m
Height	3.09m
When being operated	
Length	6.00m
Width	2.50m
Height	4.09m
Weight: 20500kg or 17500kg without saddle weights	

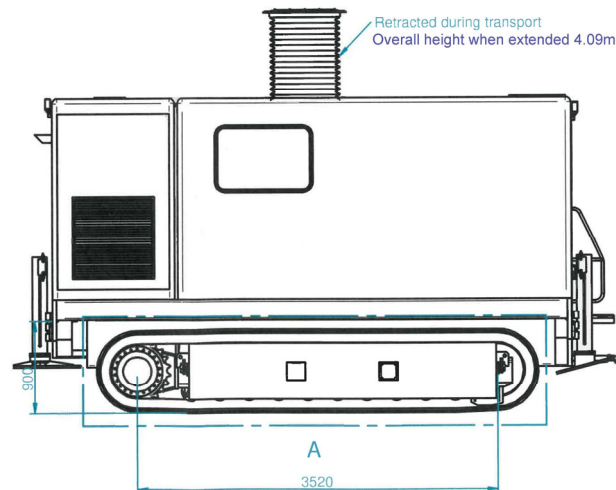
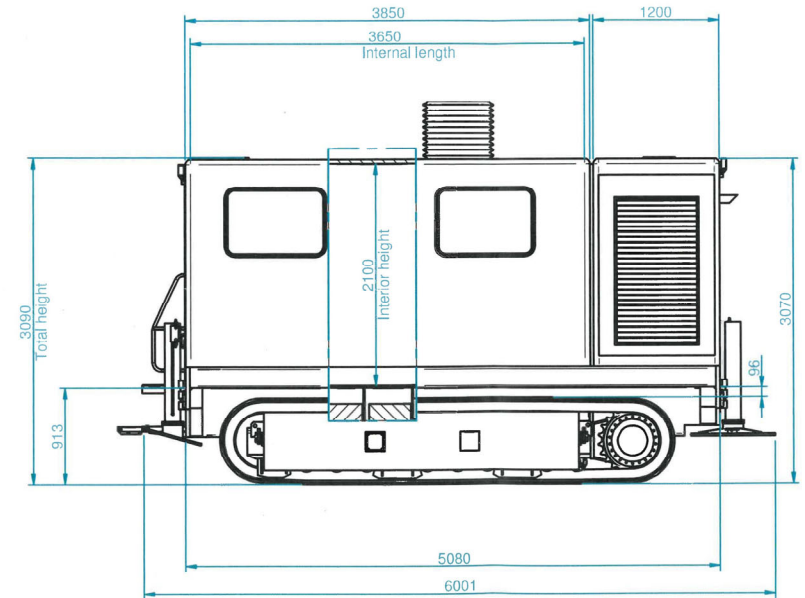
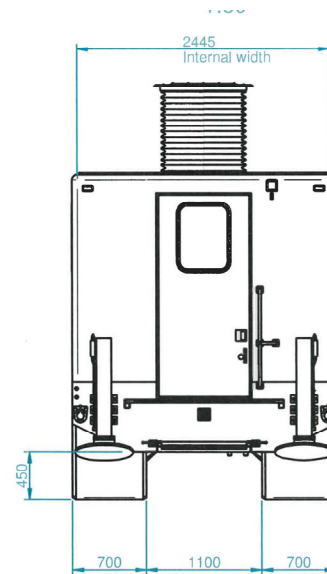

Contact: salesuk@socotec.com