

GINAF 6X6 360 CPT TRUCK DATASHEET

Cone Penetration Tests (CPT) are carried out using twenty tonne capacity hydraulic penetrometer equipment mounted on ballasted vehicles. SOCOTEC UK is accredited by the United Kingdom Accreditation Service (UKAS) to undertake electric friction and piezocone testing as detailed in its UKAS schedule, Laboratory No 0001.

All CPT vehicles are fitted with a computerised logging system which displays a continuous graphical record of the measured data against depth. Data plots can be produced and supplied to the Client in the field upon completion of the testing.

TRUCK MOUNTED PENETROMETER

- ▶ Road-going truck mounted unit with enclosed cab and CPT rig
- ▶ Ideal for rapid mobilisation to sites with drive on access as well as sites with a security risk
- ▶ 200kN CPT pushing platform
- ▶ Maximum depth of penetration 40m dependant on ground conditions
- ▶ Production rate of up to 150m per day



Contact: salesuk@socotec.com

GINAF 6X6 360 CPT TRUCK DATASHEET

When being driven

Length	8.00m
Width	2.70m
Height	3.40m

When being operated

Length	8.00m
Width	2.70m
Height	4.50m

Weight: 20000kg

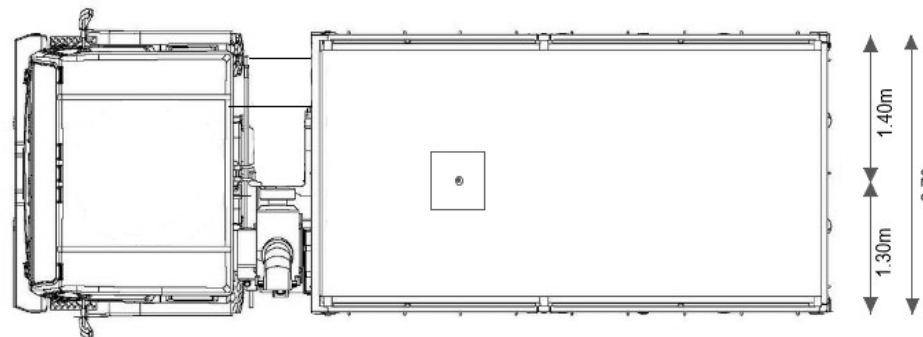
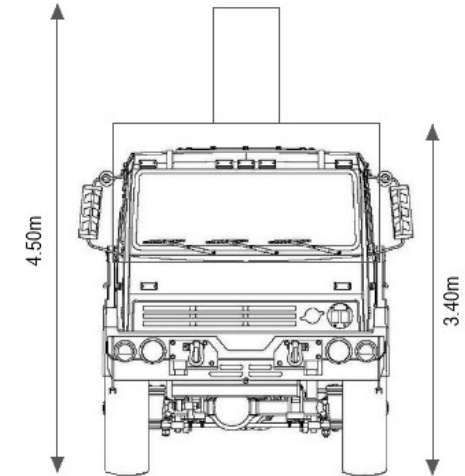
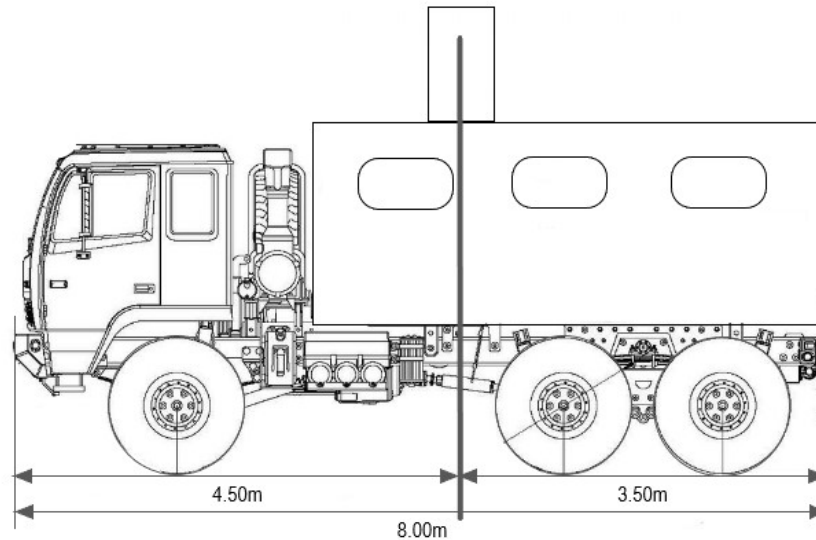

Contact: salesuk@socotec.com