

# NORCAR (TRACKED) ALL-TERRAIN WINDOW SAMPLING DRILL RIG (SOCOTEC HOLDING 2NO.)

This window sampling drill rig mast is mounted on an all-terrain tracked mini-telehandler and comes complete with support trailer with low bearing pressure wheels.

- Low ground bearing pressure set-up, reducing the need for track matting on site
- Low pressure set-up also reduced ground surface disturbance on sensitive sites
- Rotating mast, allowing for easy levelling on uneven ground
- Extending boom for working on slopes
- Slope working reduces manual handling risk involved when using modular rigs
- Centre articulation for manoeuvring in tight spaces
- Faster tracking between locations than standard rig – ideal for large and/or linear sites
- Bespoke support trailer to carry drilling equipment and samples
- Machine can be fitted with wheels on request



| Contact: [salesuk@socotec.com](mailto:salesuk@socotec.com)



# NORCAR (TRACKED) ALL-TERRAIN WINDOW SAMPLING DRILL RIG (SOCOTEC HOLDING 2NO.)

## When being transported

Length	3.75m
Width	1.60m
Height	2.28m

## When working

Length	4.30m (Without any boom extension)
Width	1.60m
Height	3.54m (max)

Weight: 2600kg -2900kg

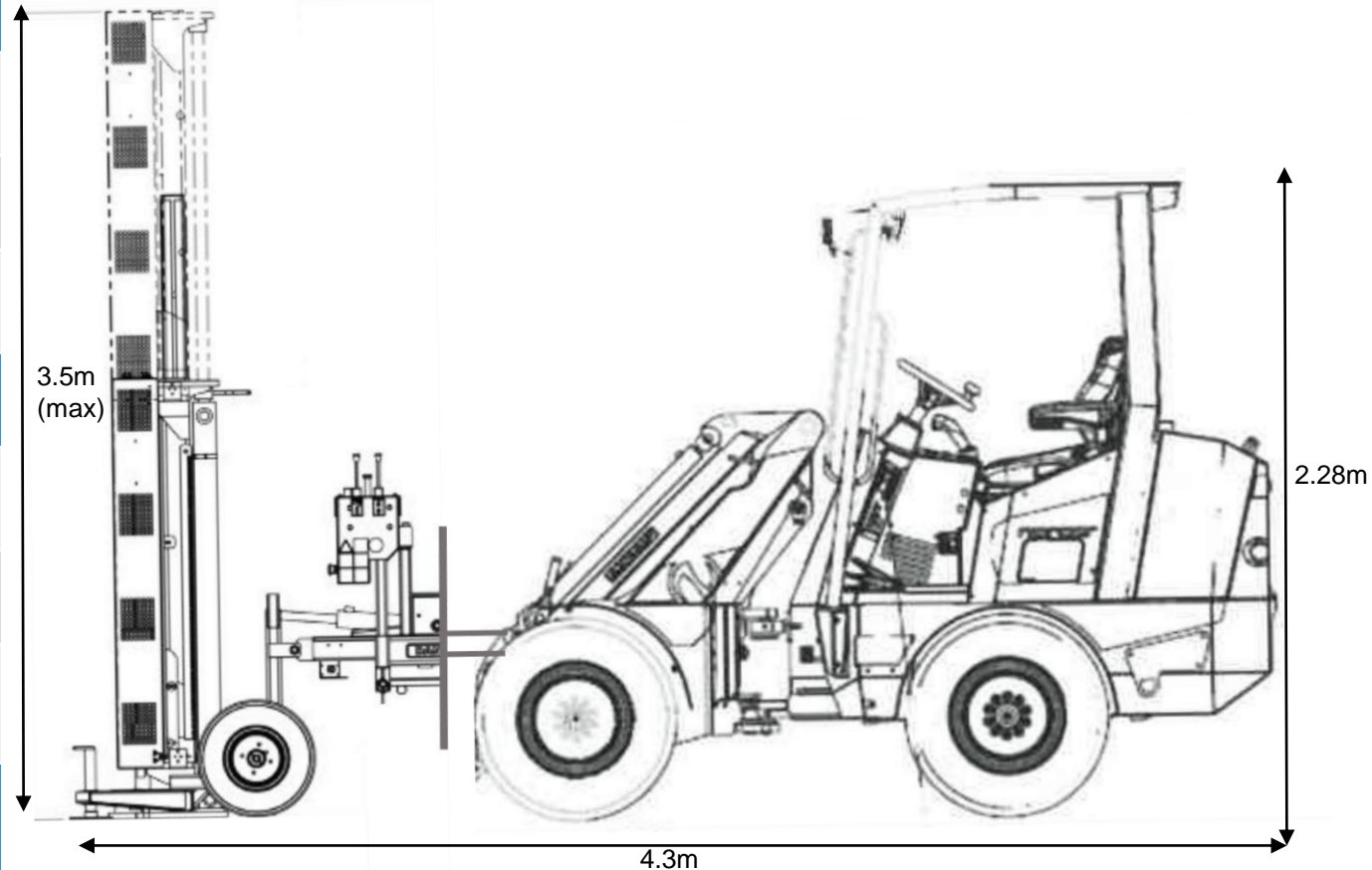

Contact: [salesuk@socotec.com](mailto:salesuk@socotec.com)