

# YANMAR C80 CPT CRAWLER DATASHEET

Cone Penetration Tests (CPT) are carried out using twenty tonne capacity hydraulic penetrometer equipment mounted on ballasted vehicles. SOCOTEC UK is accredited by the United Kingdom Accreditation Service (UKAS) to undertake electric friction and piezocone testing as detailed in its UKAS schedule, Laboratory No 0001.

All CPT vehicles are fitted with a computerised logging system which displays a continuous graphical record of the measured data against depth. Data plots can be produced and supplied to the Client in the field upon completion of the testing.

## TRACK MOUNTED PENETROMETER

- ▶ Rubber track mounted unit with open cab and CPT rams
- ▶ Ideal for very soft and/or waterlogged ground with a low ground bearing pressure of 35kPa (5 psi)
- ▶ Also suitable for sites such as alluvial and coastal floodplains with adequate capacity to penetrate the full thickness of soft alluvial sediments encountered in the UK, typically up to 10 to 15 m depth.
- ▶ 200kN CPT pushing platform with reaction weight of 9tonnes
- ▶ Maximum depth of penetration 20m dependant on ground conditions
- ▶ Production rate of up to 100m per day
- ▶ Max slope (tracking): sidehill up to 30%  
uphill up to 40%



Contact: [salesuk@socotec.com](mailto:salesuk@socotec.com)

# YANMAR C80 CPT CRAWLER DATASHEET

When being tracked	
Length	4.90m
Width	2.70m
Height	3.40m
When being operated	
Length	4.90m
Width	2.70m
Height	4.60m
<b>Weight: 9000kg</b>	

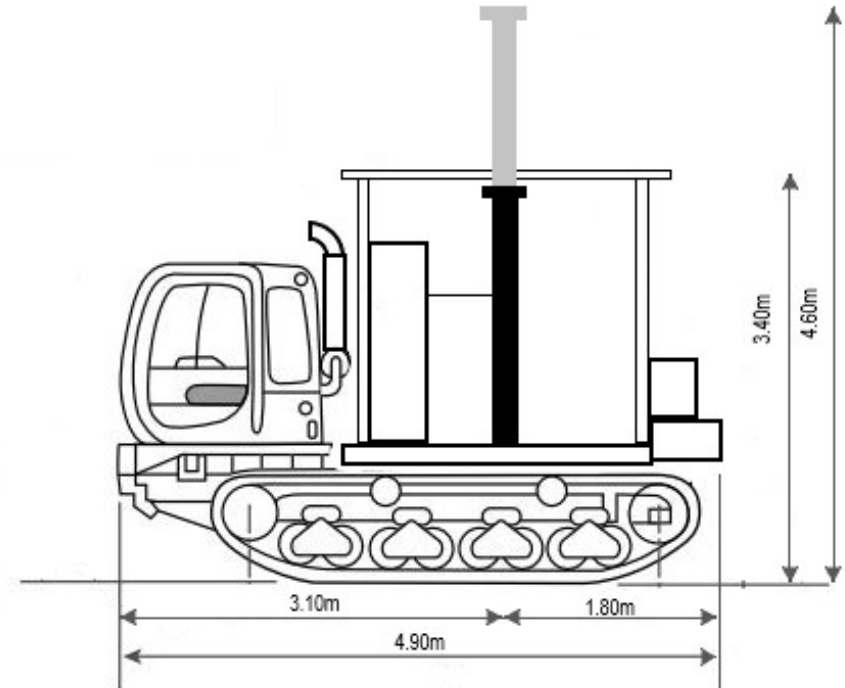
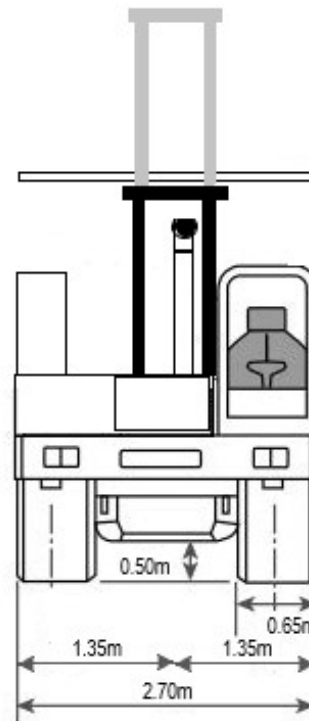

Contact: [salesuk@socotec.com](mailto:salesuk@socotec.com)