

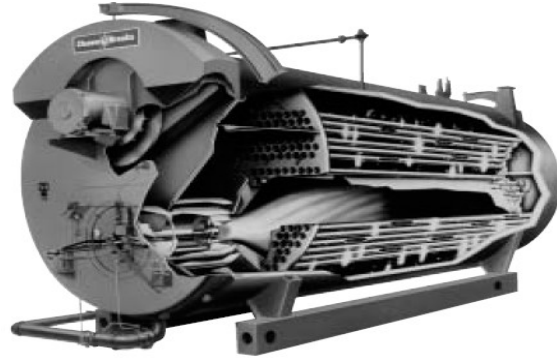

T M Service Company

Reserve the dates that best fit your operations while they're available!



Dear valued Customer,

With summer fast approaching, it is time to plan for an Annual Inspection on your Boiler / Burner unit(s). We at T M Service Company are prepared to offer you the following services at a set rate.

Once all steam and water is removed from the unit(s) we:

- Open all access points to the fireside of the boiler.
- Open all access points to the waterside and columns.
- Clean all fire and waterside surfaces from soot or foreign matter.
- Inspect and repair any cracks in refractory exceeding recommended width for expansion.
- Remove, inspect, clean and re-install the low water cut off assemblies and pump controls and gauge glass.
- We will also perform and complete any minor repairs at the time of service.
- Upon completion of inspection, close all access points utilizing factory approved parts and materials!

Once the Boiler(s) are closed:

- We test and adjust all safety devices and limit switches on the boiler to ensure proper operation.
- Fire the boilers and gently heat and pressurize the systems in a safe manner prior to returning unit back into active service.
- Perform combustion analysis with calibrated Flue Gas instrumentation.
- Correct combustion to improve any faults in performance or efficiency to ensure peak performance.
- Inspection of all controls will be performed and documented.
- Should we encounter any concerns or questions on pressure vessels or controls, we will bring them to your attention at the time of service in order for a quick remedy to assure you worry free boiler operation. We will supply the owner with inspection and combustion analysis report following the service.

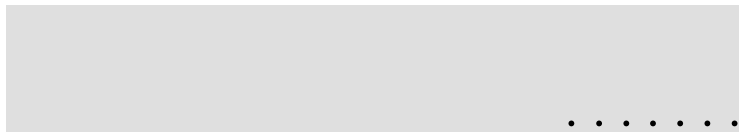

- ❖ *Our technicians are factory trained and safety certified.*
- ❖ *We stock all factory authorized OEM parts as well as complete line of retrofit parts for discontinued Manufacturer items.*
- ❖ *Our technicians are annually certified by our written safety program in job safety, confined space entry, electrical, steam, hazardous chemicals, personal protective equipment, OSHA regulations, combustible gases, lock-out/ tag –out, and are proven drug-free. We are an ISN certified company!*
- ❖ *We supply, install, and service the cutting edge in boiler safety and performance backed by the greatest boiler manufacturers in the industry.*
- ❖ *We are prepared to meet our competitor's prices. Please provide info to ensure an accurate application and quotation for your equipment.*

Please Note:

- *Boilers occasionally require additional materials to perform the repairs and can cost extra.*
- *Gasket kit consists of NEW: Fireside gaskets for required inspection points and refractory materials are limited to one (1) bucket per boiler for wash-coat and minor repair.*
- *For Cleaver-Brooks' Low Emissions (LE) Boilers - please call for pricing confirmation.*
- *For Weekend and Holiday inspections all labor billed as time and material. Please call for Estimate/Availability.*
- *Travel charges may apply depending upon location.*

We will also provide you with:

- | | | |
|--|---|---------------------------------------|
| ➤ <i>Refractory Replacement</i> | ➤ <i>Scheduled Maintenance Programs</i> | ➤ <i>Steam Service Equipment</i> |
| ➤ <i>Control & Efficiency Upgrades</i> | ➤ <i>Burner Conversions</i> | ➤ <i>Deaerators</i> |
| ➤ <i>Troubleshooting</i> | ➤ <i>Re-tubes</i> | ➤ <i>Water Softeners</i> |
| ➤ <i>Efficiency Calculations</i> | ➤ <i>“R” Stamp weld repair</i> | ➤ <i>Heat Exchangers</i> |
| | ➤ <i>Removals/ Installations</i> | ➤ <i>Portable Boiler Room Rentals</i> |
| | | ➤ <i>Combustion Analysis</i> |

Let us perform at our peak for you!

Sincerely,



Bruce Richards
 Aftermarket Sales
 Office 303-781-7878
 Mobile 303.974.0275
 brucer@tbmansfield.com