

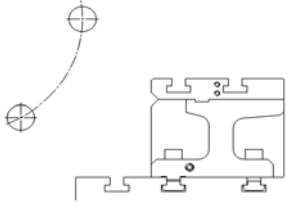

Indice generale-Index

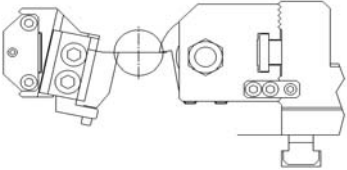

	<p>PONTI BRIDGE</p> <p>PAG. 1.0</p>
	<p>TORRETTE PORTA UTENSILI CIRCOLARI E PRISMATICI PER POS.1-6 E 1-8 SOTTO IL PONTE TURRETS,CIRCULAR TOOLHOLDERS AND DOVETAIL TOOLHOLDERS FOR POS.1-6 AND 1-8 UNDER IMG BRIDGE</p> <p>PAG. 2.0 PAG. 3.0</p>
	<p>TORRETTE PORTA UTENSILI A BARRETTA E PRISMATICI PER POS.1-6 E 1-8 SOTTO IL PONTE TIPO STRETTO TURRETS NARROW TYPE,SQUARE TOOL BIT AND DOVETAIL TOOLHOLDERS FOR POS.1-6 AND 1-8 UNDER IMG BRIDGE</p> <p>PAG. 4.0</p>
	<p>TORRETTE,PORTA UTENSILI PRISMATICI E A BARRETTA CON REGOLAZIONE RADIALE TURRETS,DOVETAIL TOOLHOLDERS AND SQUARE TOOLBIT WITH RADIAL ADJUSTMENT</p> <p>PAG. 5.0</p>
	<p>Torrette e porta utensili prismatici;prismatici piatti e a barretta Turrets and flat toolholders;devetail toolholders;square tool bit</p> <p>PAG. 6.0</p>
	<p>TORRETTE,PORTA LAME EMPIRE CON REGOLAZIONE RADIALE TURRETS AND EMPIRE PART OFF TOOLHOLDERS WITH RADIAL ADJUSTMENT</p> <p>PAG. 7.0</p>
	<p>PORTA UTENSILI A BARRETTA PER SUPPORTO CENTRALE KNEE TURNING TOOLHOLDER FOR SQUARE TOOL BIT</p> <p>PAG. 8.0</p>

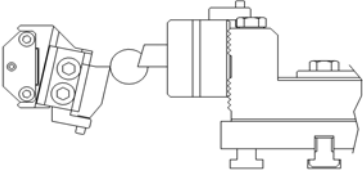
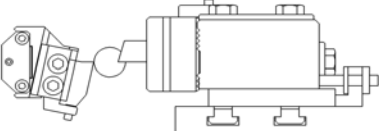
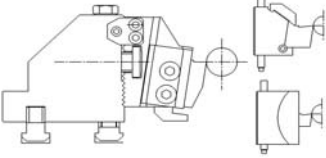
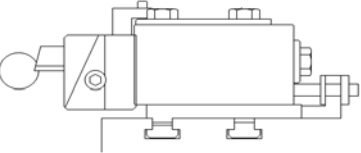
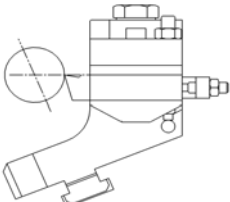

Indice generale-Index

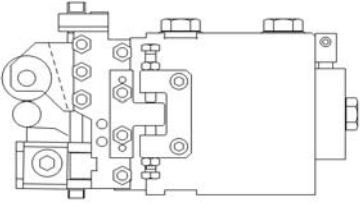
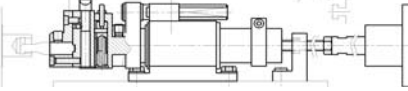
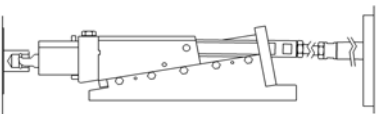
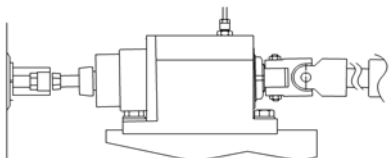
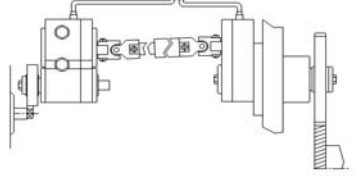
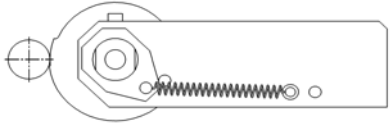
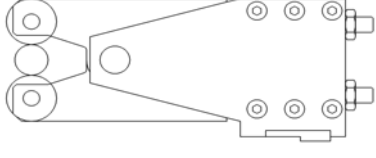
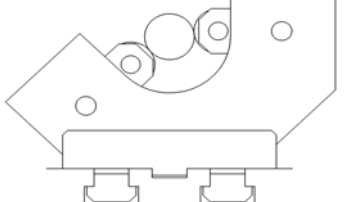

	Calibratori Shaving toolholder PAG. 9.0 PAG. 14.0 PAG. 10.0 PAG. 15.0 PAG. 11.0 PAG. 16.0 PAG. 12.0 PAG. 17.0 PAG. 13.0 PAG. 18.0
	Testina per recessi a spinta Push type recessing slide PAG. 19.0
	Testine per recessi a rampa Ramp type recessing slide PAG. 20.0
	BROCCIATORI BROACHING ATTACHMENT PAG. 21.0
	Poligonale fresa filetti spacco sfera Flat generating(Polygonal) thread milling ball slots PAG. 22.0 PAG. 26.0 PAG. 23.0 PAG. 27.0 PAG. 24.0 PAG. 25.0
	Marcatori Marking rolls PAG. 28.0 PAG. 32.0 PAG. 36.0 PAG. 29.0 PAG. 33.0 PAG. 37.0 PAG. 30.0 PAG. 34.0 PAG. 31.0 PAG. 35.0
	Rullatori e godronatori Burnishing and knurling roll holders PAG. 38.0
	Porta rulli di sostegno Steady roll holders PAG. 39.0

PONTI BRIDGES

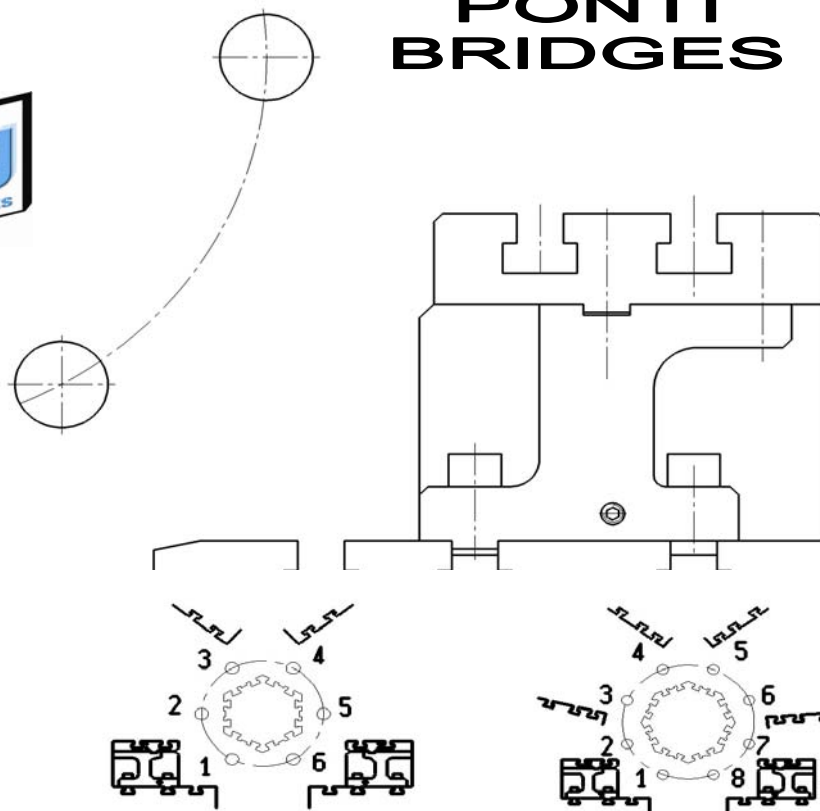

ACME GRIDLEY

MODELLO MODEL	POS.	PONTE BRIDGE
9/16" RA6-1"RA6	1-2-5-6	A160200
1 1/4" RA6	1-2-5-6	A160100
1 1/4" RA6 C.N.C. SLIDE	1-2	A161200
1 1/4" RA6 C.N.C. SLIDE	5-6	A161300
2 5/8" RB6	1-2-5-6	A160600
1 1/4" RB8	1-2-7-8	A160300
2 5/8" RB8	1-2-7-8	A160400

PITTLER

MODELLO MODEL	POS.	PONTE BRIDGE
PRC 72/8	1-8	A161400

TORRETTE E PORTA UTENSILI PRISMATICI TURRET AND DOVETAILS TOOLHOLDERS

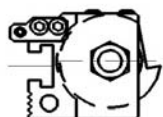
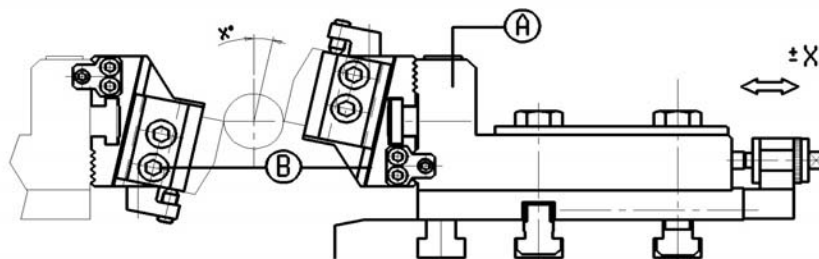

PORTA UTENSILE CIRCOLARE
VEDI PAG.A15

CIRCULAR TOOLHOLDER
SEE PAG.A15

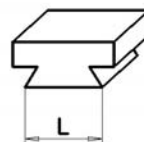
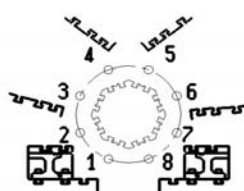
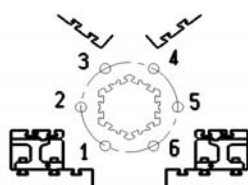
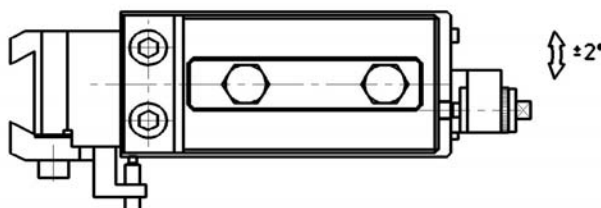

PONTE IMG - BRIDGE IMG

ACME GRIDLEY

MODELLO MODEL	POS.	TORRETTA (A)+ ADATTATORE (B)	PORTA UTENSILE -C- TOOLHOLDER -C- X=12°		
		TURRET (A)+ ADAPTOR (B)	ATTACCO -L- SHANK -L-		
			24,15	41(1")	47,8(1"1/4)
9/16" RA6-1" RA6	1-6	A172700	*	*	*
1 1/4" RA6	1-6	A172800	*	*	*
2 5/8" RB6	1-6	A173400	*	*	*
1 1/4" RB8	1-8	A172400	*	*	*
1 5/8" RBN8	1-8	A172400	*	*	*
2 5/8" RB8	1-8	A170600	*	*	*

TORRETTE E PORTA UTENSILI CIRCOLARI TURRET AND CIRCULAR TOOLHOLDERS

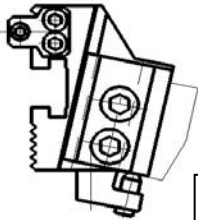
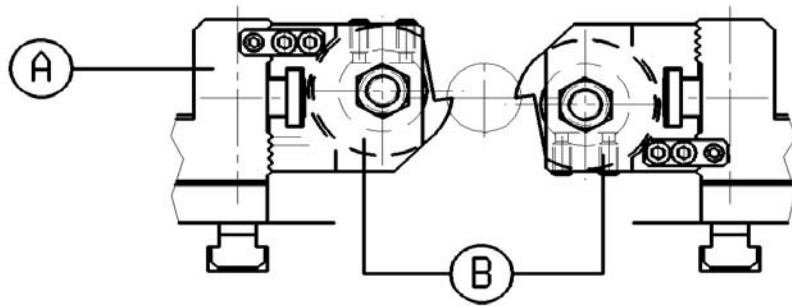

A=16 ; 5
B=50 ; 39

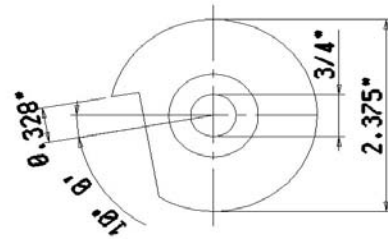
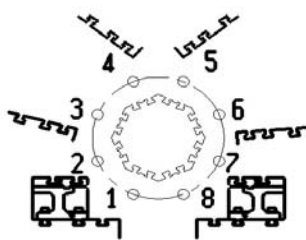
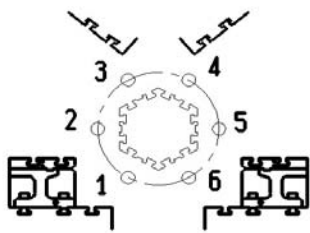
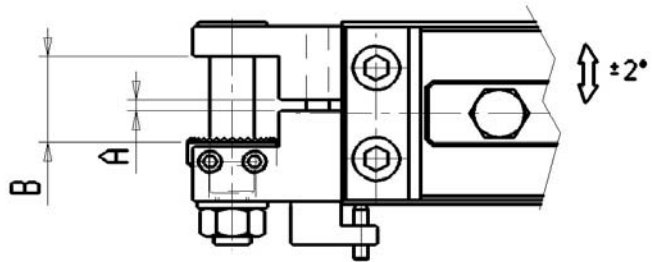

PONTE IMG - BRIDGE IMG

ACME GRIDLEY

MODELLO MODEL	POS.	TORRETTA TURRET	PORTA UTENSILE TOOLHOLDER
9/16" RA6-1"RA6	1-6	A172700	A300100
1 1/4" RA6	1-6	A172800	A300100
2 5/8" RB6	1-6	A173400	A300100
1 1/4" RB8	1-8	A172400	A300100
1 5/8" RBN8	1-8	A172400	A300100
2 5/8" RB8	1-8	A170600	A300100

TORRETTE E PORTA UTENSILI PRISMATICI TIPO STRETTO TURRET NARROW TYPE AND DOVETAIL TOOLHOLDER

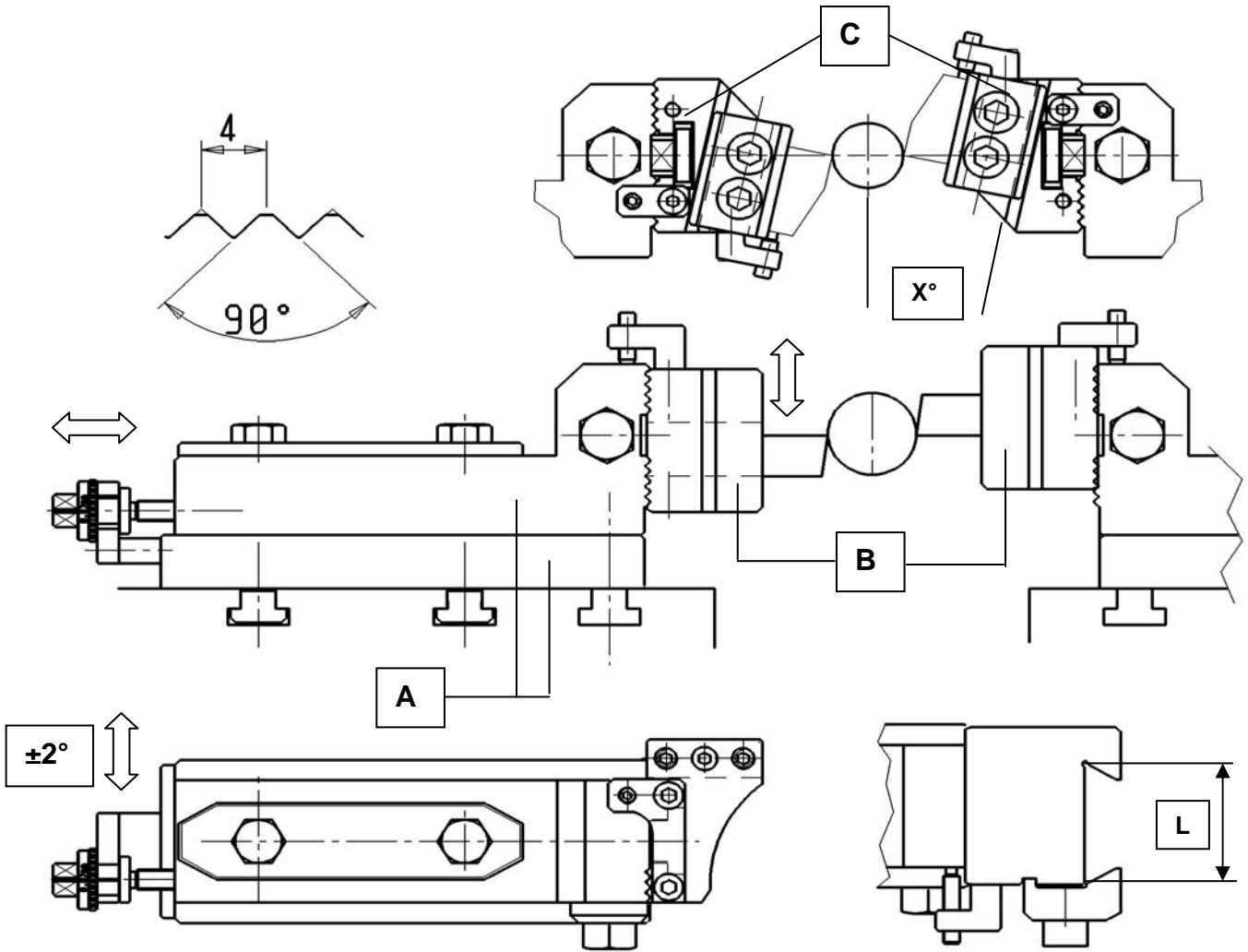
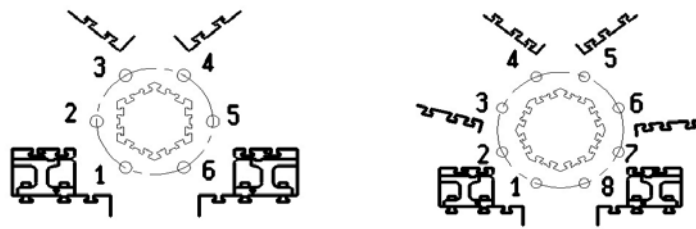

ACME GRIDLEY

PONTE IMG - BRIDGE IMG

MODELLO MODEL	POS.	TORRETTA (A)+ TURRET (A)+	PORTA UTENSILE -C- TOOLHOLDER -C- X=12° ATTACCO -L- SHANK -L-			PORTA UTENSILE TOOLHOLDER B
			24,15	41(1")	47,8(1"1/4)	
9/16" RA6-1" RA6	1-6	A320400-1	*	*	*	A320200 16x16
1 1/4" RA6	1-6	A321200	*	*	*	A320200 16x16
1 1/4" RB8	1-8	A321500	*	*	*	A320200 16x16
1 5/8" RBN8						

TORRETTE E PORTA UTENSILI PRISMATICI CON REGOLAZIONE RADIALE

TURRET AND DOVETAIL TOOLHOLDER WITH RADIAL ADJUSTMENT

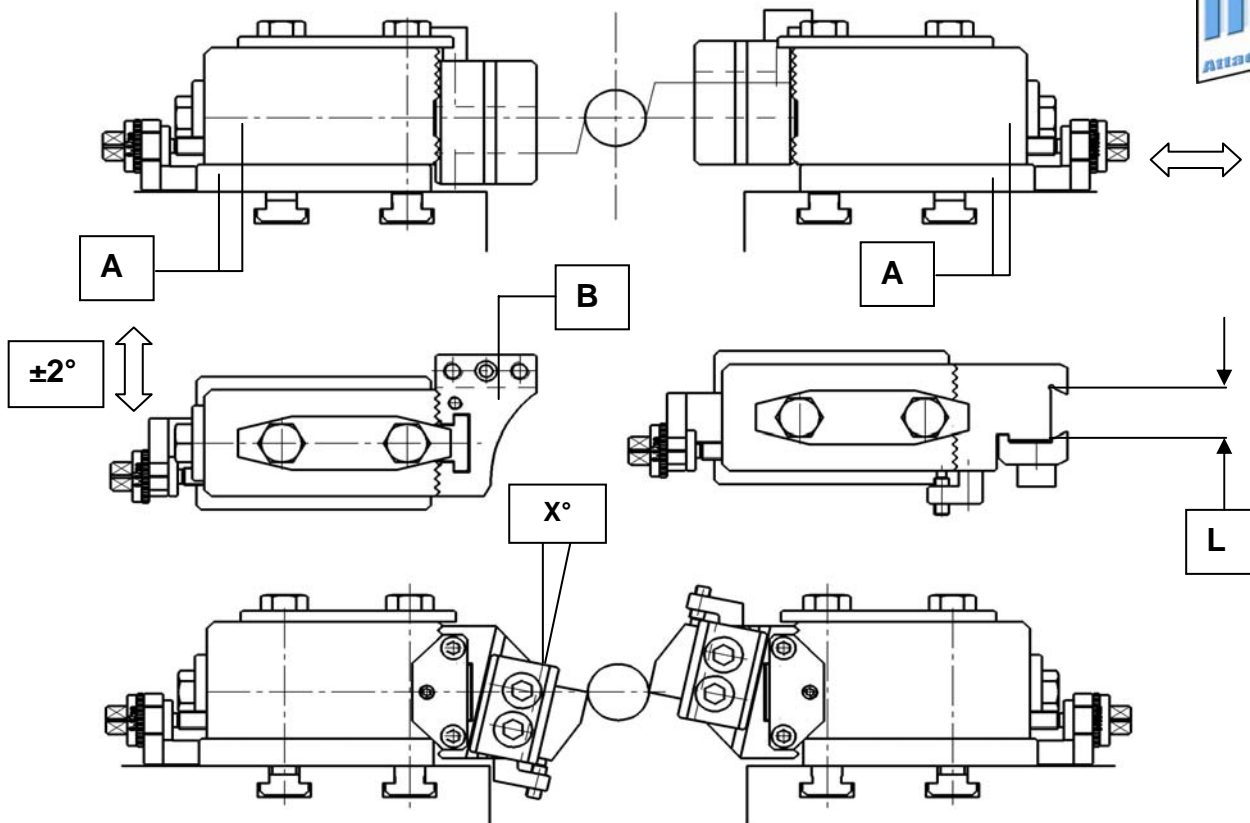

ACME GRIDLEY

MODELLO MODEL	POS.	TORRETTA A TURRET	PORTA UTENSILE TOOLHOLDER X=12° ATTACCO -L- SHANK -L-			PORTA UTENSILE TOOLHOLDER B
			24,15	41(1")	47,8(1"1/4)	
9/16" RA6-1" RA6	1-6 senza ponte-without bridge pos.2 con ponte-with bridge img	A320100	*	*	*	A320200
	2-3-4 SU SLITTE ACME- ON ACME SLIDES	A320300	*	*	*	A320200
1 1/4" RA6	1-6 senza ponte-without bridge pos.2 con ponte-with bridge img	A320800	*	*	*	A320200
	2-3-4 SU SLITTE ACME- ON ACME SLIDES	A321100	*	*	*	A320200
3/4" RA8	3-4-5-6 SU SLITTE ACME- ON ACME SLIDES	A320300	*	*	*	A320200
1 1/4" RB8- 1 5/8" RBN8	1-2-3-4-5-6-8 CON PONTE-WITH IMG BRIDGE	A321600	*	*	*	A320200

NEW BRITAIN

MODELLO MODEL	POS.	TORRETTA TURRET	PORTA UTENSILE TOOLHOLDER X=12° ATTACCO -L- SHANK -L-			PORTA UTENSILE TOOLHOLDER B
			24,15	41(1")	47,8(1"1/4)	
MOD.51 -52	1-2-3-4-5	A321400	*	*	*	A320200

TORRETTE E PORTA UTENSILI PRISMATICI CON BLOCCAGGIO RAPIDO TURRET AND DOVETAIL TOOLHOLDER WITH FAST SHANK

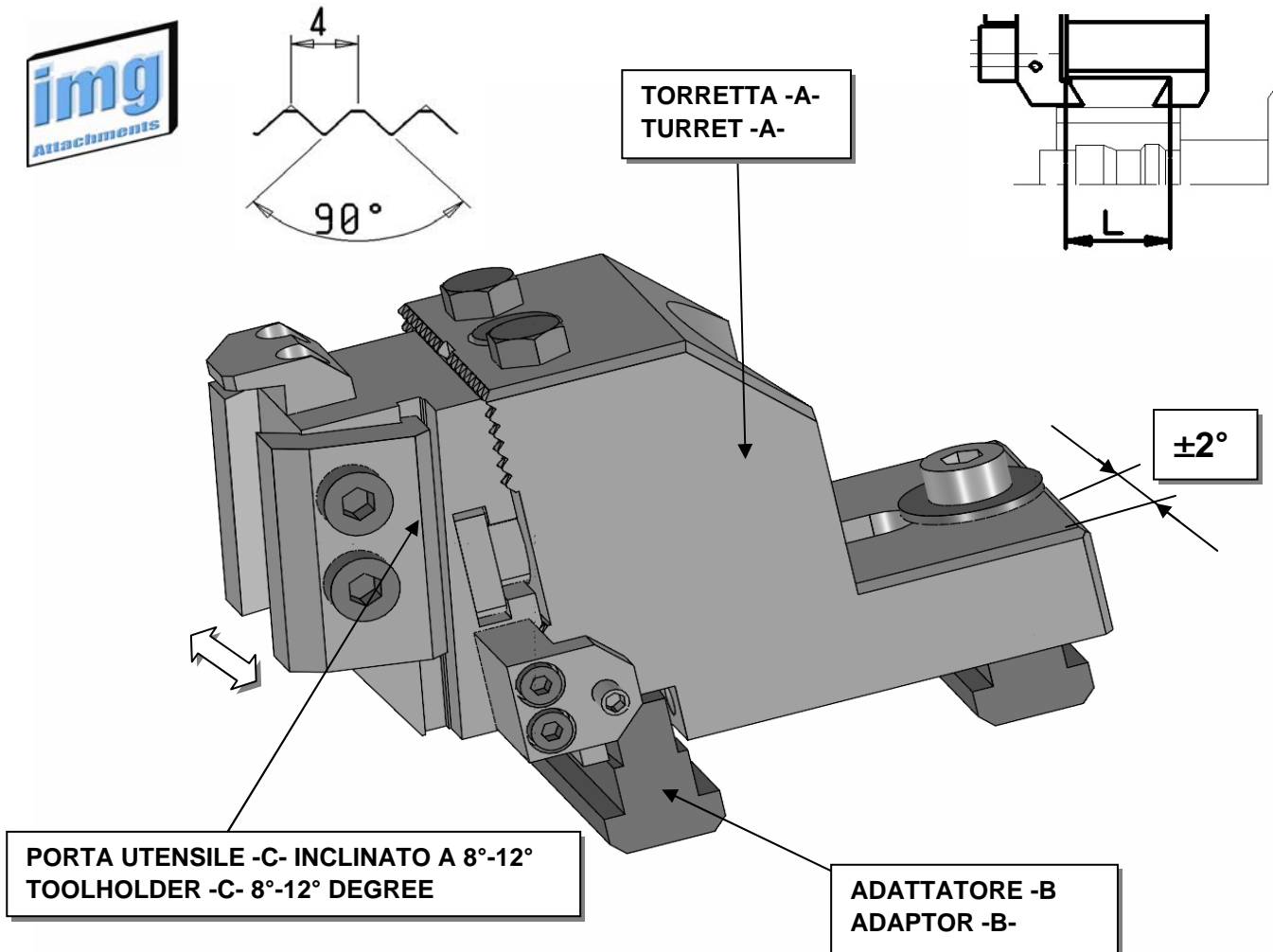

ACME GRIDLEY

MODELLO MODEL	POS.	TORRETTA (A)+ ADATTATORE (B)	PORTA UTENSILE TOOLHOLDER X=12°		
		TURRET (A)+ ADAPTOR (B)	ATTACCO -L- SHANK -L-		
			24,15	41(1")	47,8(1"1/4)
9/16" RA6-1" RA6	3-4	8729400	*	*	*
1 1/4" RA6-	1-6	8731100	*	*	*
	3-4	8731200	*	*	*
1 5/8" RB6	3-4	8731200	*	*	*
1 5/8" RBN8	1-3-4-5-6-8	8731200	*	*	*
1 5/8" RA8	3-6	878400+878300	*	*	*
1 5/8" RA8	1-8-4-5	876000-1+878300	*	*	*
2 5/8" RA6	1-6	8728600	*	*	*
2 5/8" RA6	3-4	8728300	*	*	*
3 1/2" RA6	1-3-4-6	8728300	*	*	*

ALTRI ATTACCHI -L- A RICHIESTA

TORRETTE E PORTA LAME EMPIRE CON REGOLAZIONE RADIALE

TURRET AND EMPIRE PART OFF WITH RADIAL ADJUSTMENT

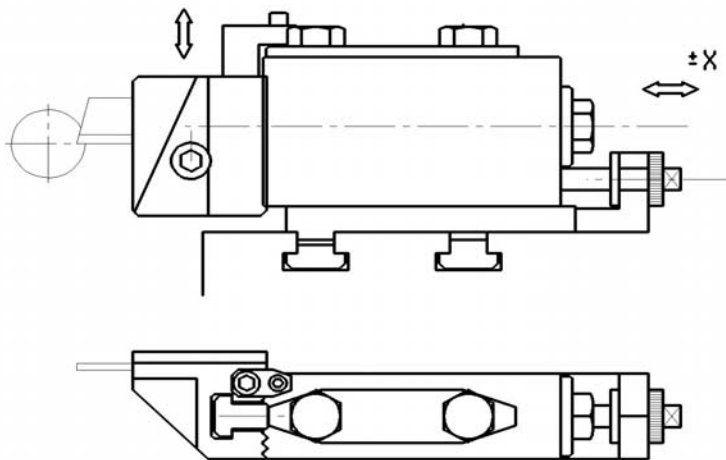

N.B. IL PORTA UTENSILE E' COMPLETO DI UNA STAFFA
NOTE: TOOLHOLDER IS SUPPLIED WITH ONE CLAMP

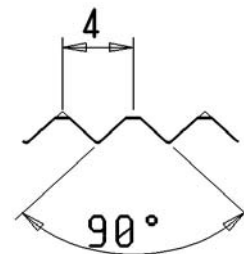
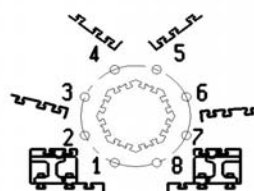
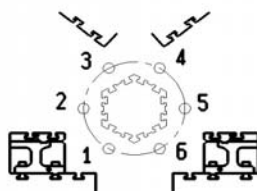

ACME GRIDLEY

MODELLO MODEL	POS.	TORRETTA TURRET	PORTA UTENSILE TOOLHOLDER
9/16" RA6- 1" RA6	5 CON PONTE IMG-WITH IMG BRIDGE	A320700	A320500
9/16" RA6- 1" RA6	5 CON SLITTE ACME-WITH ACME SLIDES	A320600	A320500
1" 1/4 RA6	5 CON PONTE IMG-WITH IMG BRIDGE	A323700	8732800
1" 1/4 RA6	5 CON SLITTE ACME-WITH ACME SLIDES	A321000	8732800

specificare dimensione 17x1 ; 17x2 ; 17x2,5 ; 17x3 ; 17x4 ; 17x5
specify dimension 17x1 ; 17x2 ; 17x2,5 ; 17x3 ; 17x4 ; 17x5

PORTA UTENSILI MODULARI A BARRETTA PER SUPPORTO CENTRALE MODULAR KNEE TOOLHOLDER FOR CENTRAL BLOCK



Particolarmente usato per torniture longitudinali e smussi
Suitable for longitudinal turning, chamfering and facing

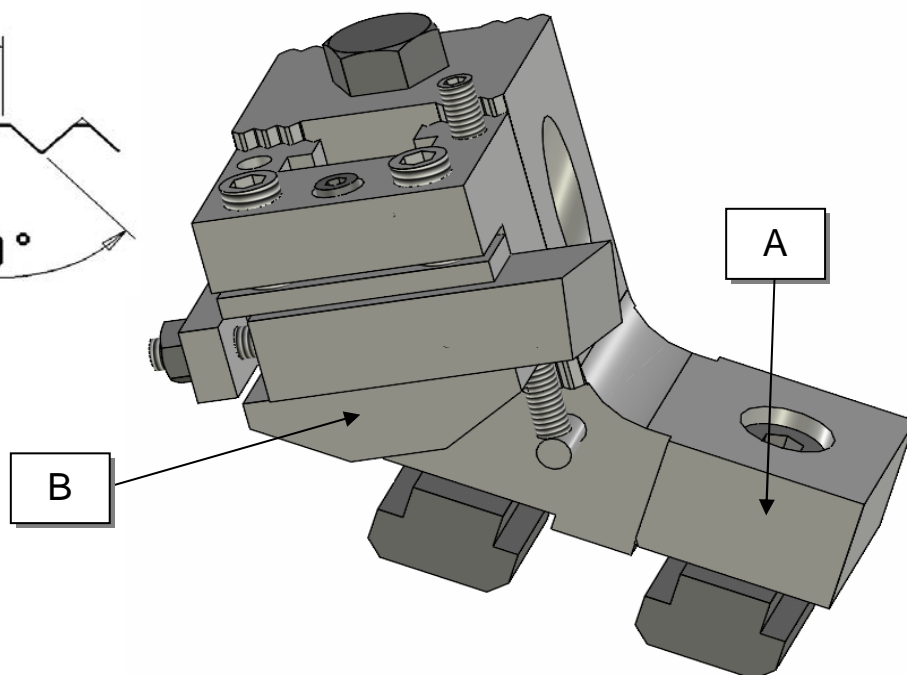
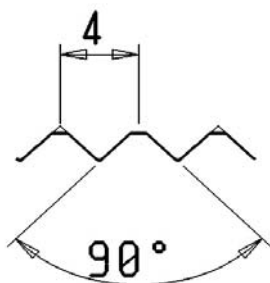

ACME GRIDLEY

MODELLO MODEL	POS.	TORRETTA (A) TURRET (A)	PORTA UTENSILE -B- TOOLHOLDER -B- ATTACCO SHANK b x h			
			10x10	12x12	16x16	20x20
1 1/4"RB8	1-2-3-4-5	9510901A			*	
1 5/8"RB6-2" RB6	1-2-3-4-5	952301A			*	
1 5/8"RB8-2" RB8	1-2-3-4-5-6-7	952301A			*	
2" 5/8 RB8	1-2-3-4-5-6-7	956101A		*		

NEW BRITAIN

MODELLO MODEL	POS.	TORRETTA (A) TURRET (A)	PORTA UTENSILE -B- TOOLHOLDER -B- ATTACCO SHANK b x h			
			10x10	12x12	16x16	20x20
MOD.51	1-2-3-4-5	958501A		*		
MOD.62	1-2-3-4-5	958601A		*		

CALBRATORI-SHAVING TOOLHOLDERS (SIZING)

CALBRATORE N°7616300-1-763600-1 PER ØA MAX 22mm
 SHAVING TOOLHOLDER N°7616300-1-763600 FOR ØA MAX Ø22mm

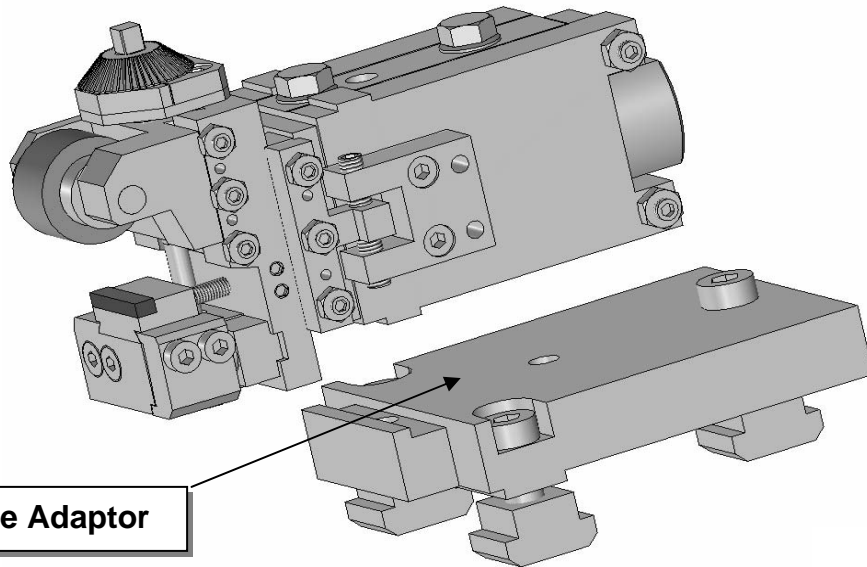

Adattatore Adaptor

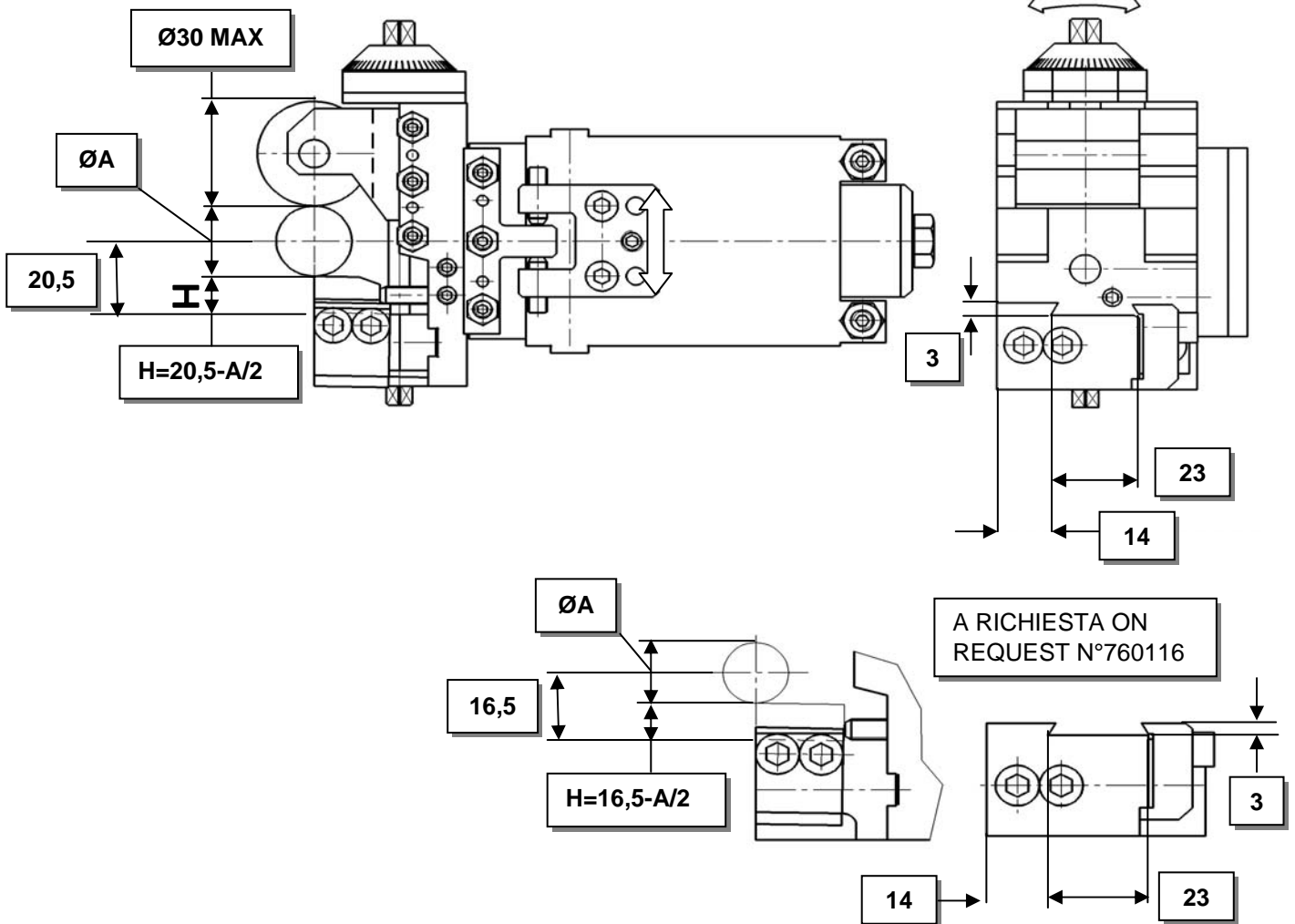

CALIBRATORI-SHAVING TOOLHOLDERS (SIZING)

CALIBRATORE N°760100-1-763600-1 PER ØA MAX 22mm

SHAVING TOOLHOLDER N°760100-1-763600 FOR ØA MAX Ø22mm

ACME GRIDLEY

MODELLO			CALIBRATORE SHAVING N°	ADATTATORE ADAPTOR N°
MODEL	POS,	A MAX		
7/16"	3-4	17	763600-1	-
9/16" RA6 - 1" RA6	3-4	17	763600-1	-

BSA

MODELLO			CALIBRATORE SHAVING N°	ADATTATORE ADAPTOR N°
MODEL	POS,	A MAX		
1"	3-4	22	7616300	761100

CALBRATORI-SHAVING TOOLHOLDERS (SIZING)

CALBRATORE N°761600-1 PER ØA MAX 26mm
 SHAVING TOOLHOLDER N°761600-1 FOR ØA MAX 26mm

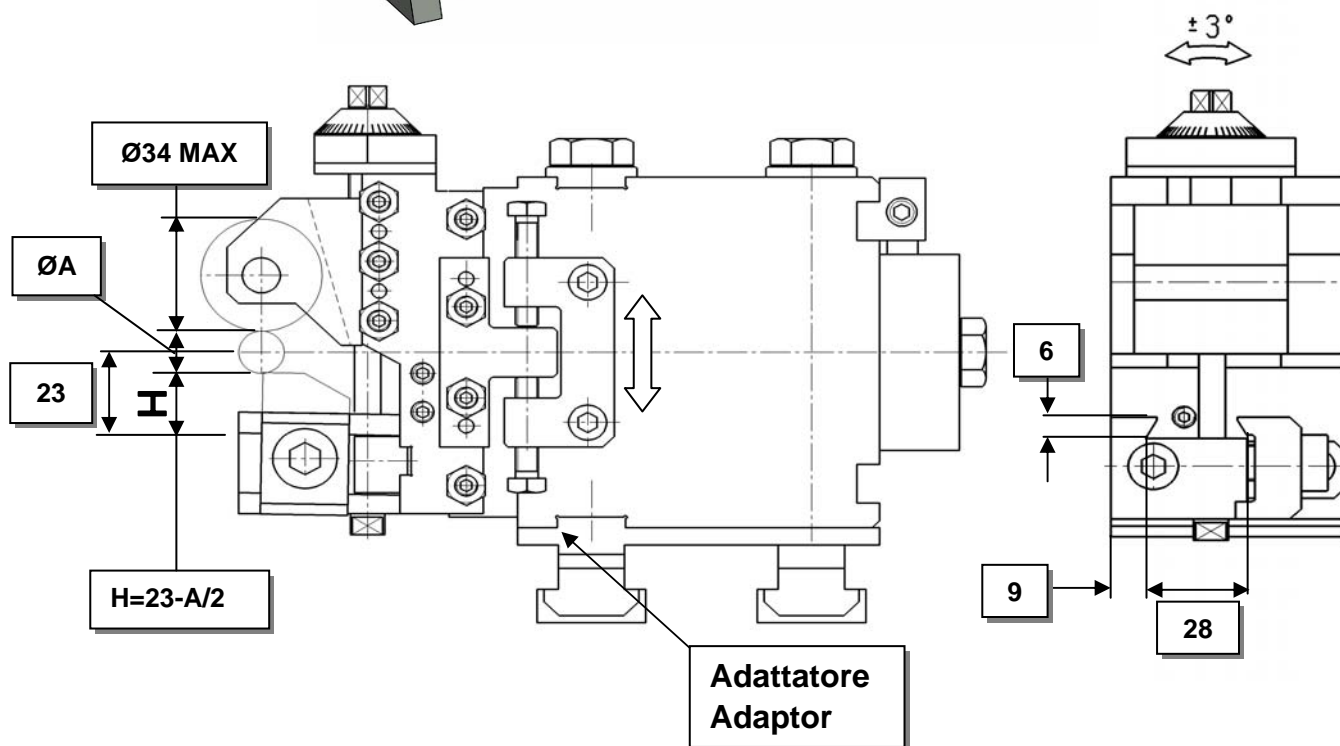
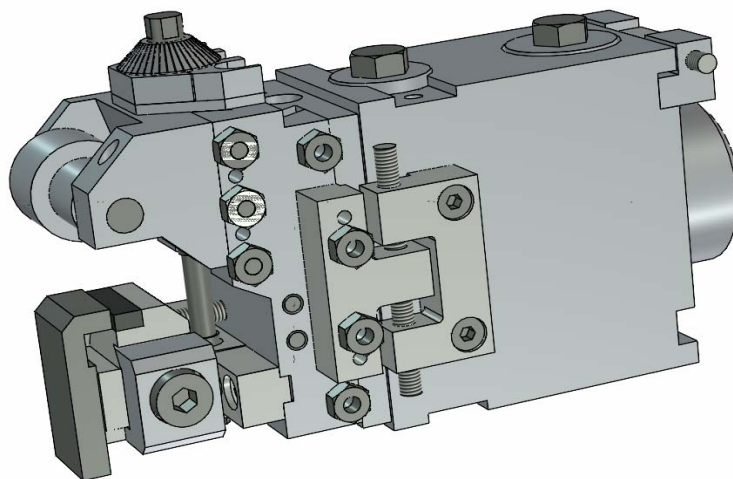

ALTRI TIPI DI ATTACCHI UTENSILE A RICHIESTA
 OTHER DOVETAIL SIZES ON REQUEST

ACME GRIDLEY

MODELLO MODEL	POS, POS,	A MAX	CALBRATORE SHAVING N°	ADATTATORE ADAPTOR N°
9/16" RA6 - 1" RA6	3-4	26	A180100	-
3/4" RA8 START N°BD70017	3-4-5-6	26	A180600	-

CALIBRATORI-SHAVING TOOLHOLDERS (SIZING)

CALIBRATORE N°760200-1 PER ØA MAX 34mm
 SHAVING TOOLHOLDER N°760200-1 FOR ØA MAX 34mm

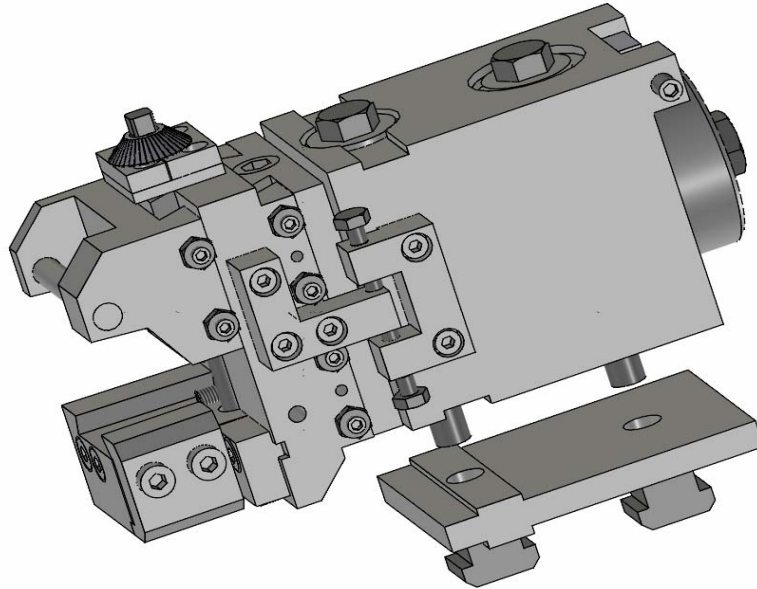

n° 760200-1

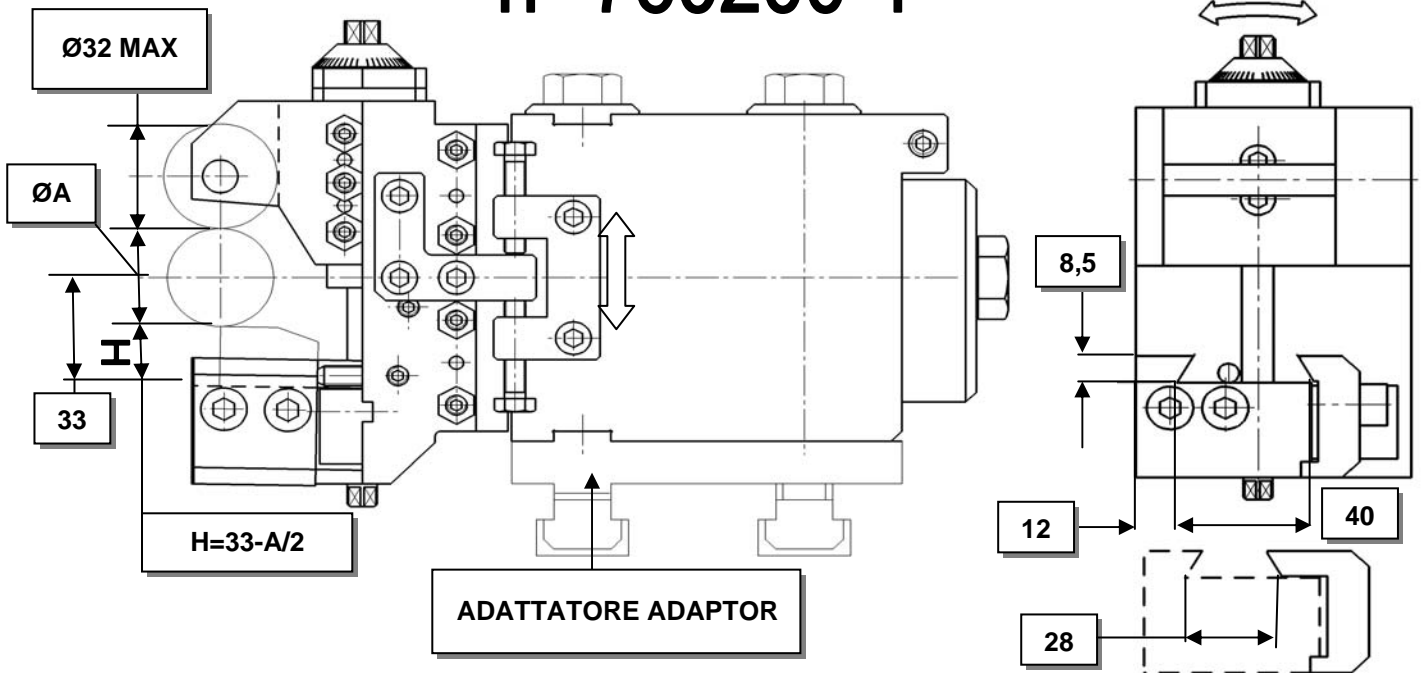

ACME GRIDLEY

MODELLO	POS,	A MAX	CALIBRATORE SHAVING N°	ADATTATORE ADAPTOR N°
MODEL				
1 1/4" RA6	3-4	34	760200-1	760200-1
1 1/4" RB8 1 5/8" RBN8	3-4-5-6	34	760200-1	760200-1

CALBRATORI-SHAVING TOOLHOLDERS (SIZING)

CALBRATORE N°766000 PER ØA MAX 46mm
SHAVING TOOLHOLDER N°766000 FOR ØA 46mm

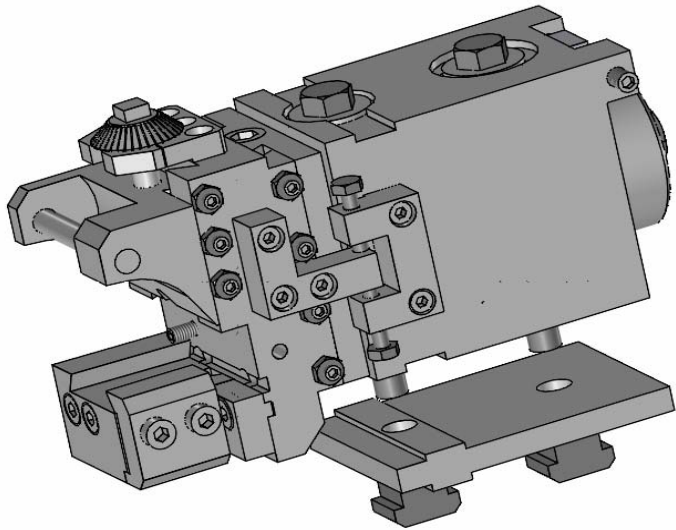

n° 766000

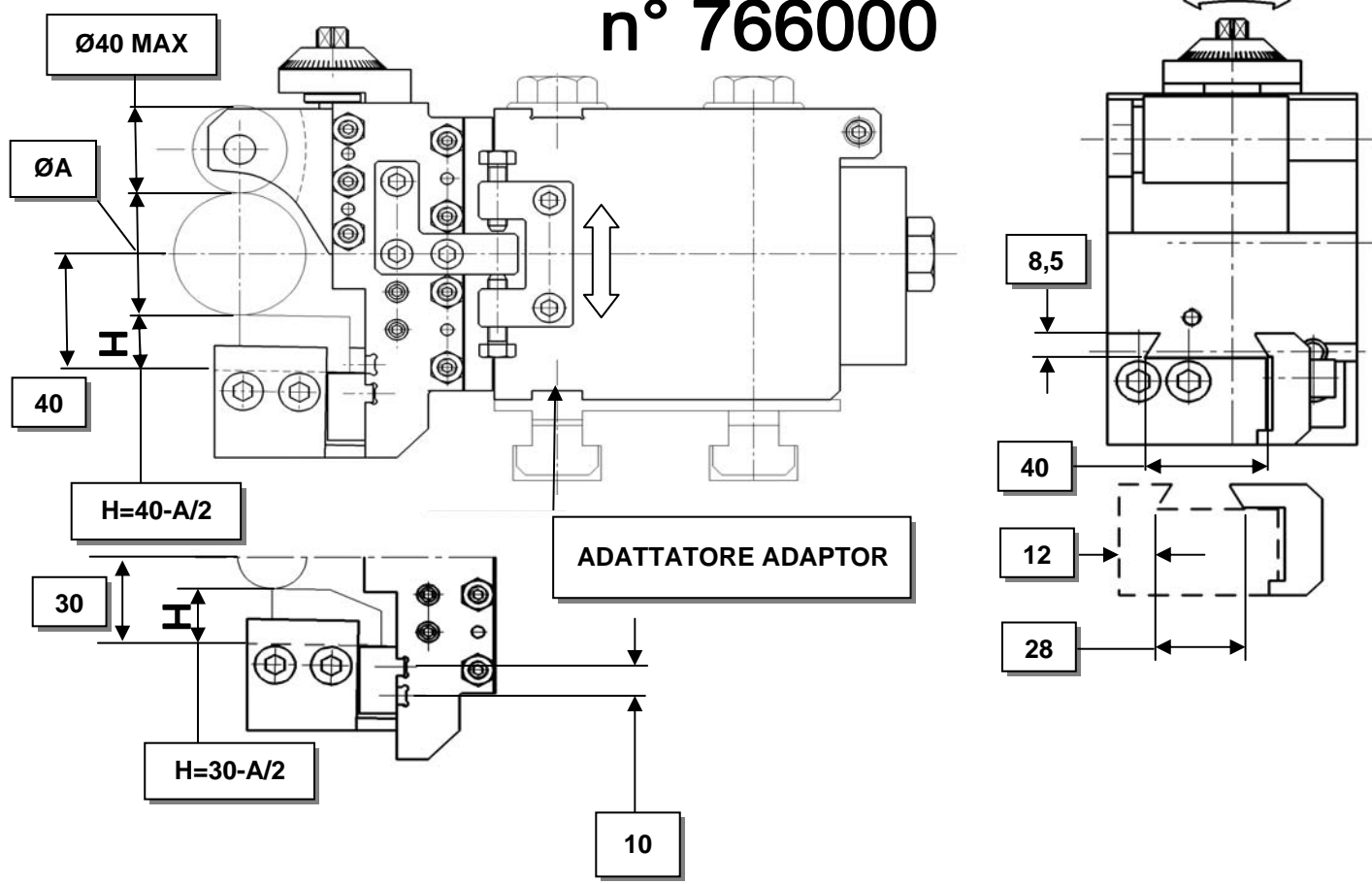

CALBRATORI-SHAVING TOOLHOLDERS (SIZING)

CALBRATORE N°766000 PER ØA MAX 46mm
 SHAVING TOOLHOLDER N°766000 FOR ØA 46mm

ACME GRIDLEY

MODELLO MODEL	POS,	A MAX	CALBRATORE SHAVING N°	ADATTATORE ADAPTOR N°
1 1/4" RB8 1 5/8 RBN8	3-4-5-6	46	766000	7610200
1 5/8 RB6 2" RB6	4-5	46	766000	765800
1 5/8 RB6 2" RB6	3-6	46	766000	7610200

PITTLER

MODELLO MODEL	POS,	A MAX	CALBRATORE SHAVING N°	ADATTATORE ADAPTOR N°
PRC 25/8 PRB 32/8	3-4-5-6	46	766000	760700
PRC 32/6 PRB 36/6	3-4-5-6	46	766000	760700
PRCF 160/8	3-4-5-6	46	766000	762600
PRC 72/8	3-4	46	766000	760700

CALBRATORI-SHAVING TOOLHOLDERS (SIZING)

CALBRATORE N°760600-1 PER ØA MAX 50mm
SHAVING TOOLHOLDER N°760600-1 FOR ØA MAX 50mm

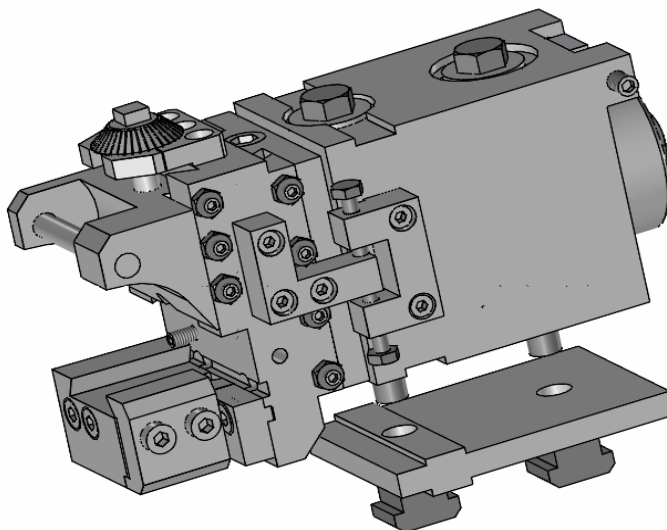

n° 760600-1 ; 7611600-1

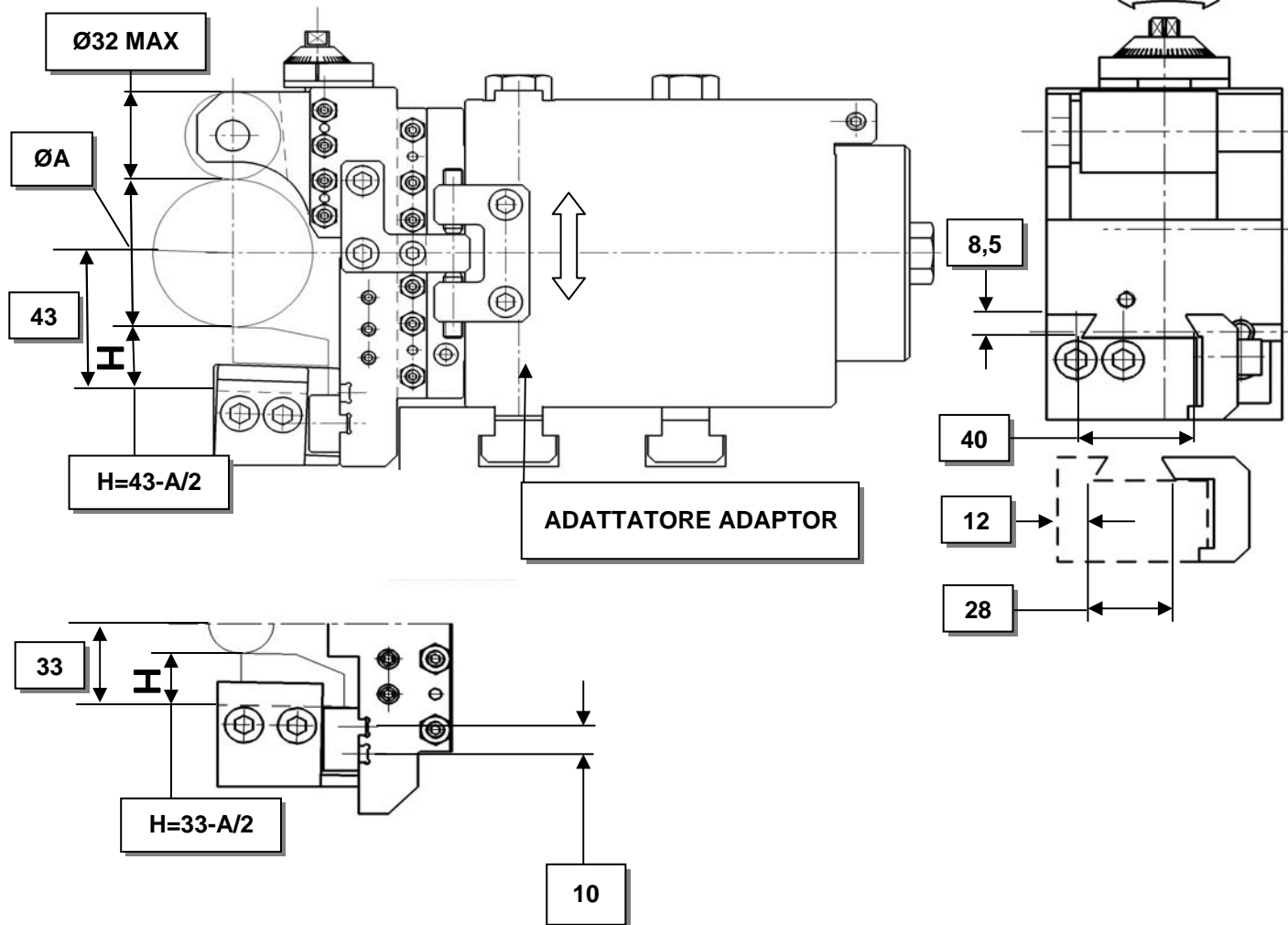

CALIBRATORI-SHAVING TOOLHOLDERS (SIZING)

CALIBRATORE N°760600-1 PER ØA MAX 50mm
SHAVING TOOLHOLDER N°760600-1 FOR ØA MAX 50mm

ACME GRIDLEY

MODELLO			CALIBRATORE SHAVING N°	ADATTATORE ADAPTOR N°
MODEL	POS,	A MAX		
2 5/8" RB6	3-4	50	760600-1	7611300
3 1/2" RB6	3-4	50	760600-1	7611300
2 5/8" RB8	3-4-5-6	50	760600-1	768000
2 5/8" RB8	4-5	61	7611600-1	/
3 1/2" RB8	3-4	50	760600-1	7611300

PITTLER

MODELLO			CALIBRATORE SHAVING N°	ADATTATORE ADAPTOR N°
MODEL	POS,	A MAX		
PRCF 160/8	3-4-5-6	50	760600-1	762600
PRC 50/6	3-4	50	760600-1	762600

CALIBRATORI CON REGOLAZIONE RADIALE SHAVING TOOLHOLDER WITH RADIAL ADJUSTMENT

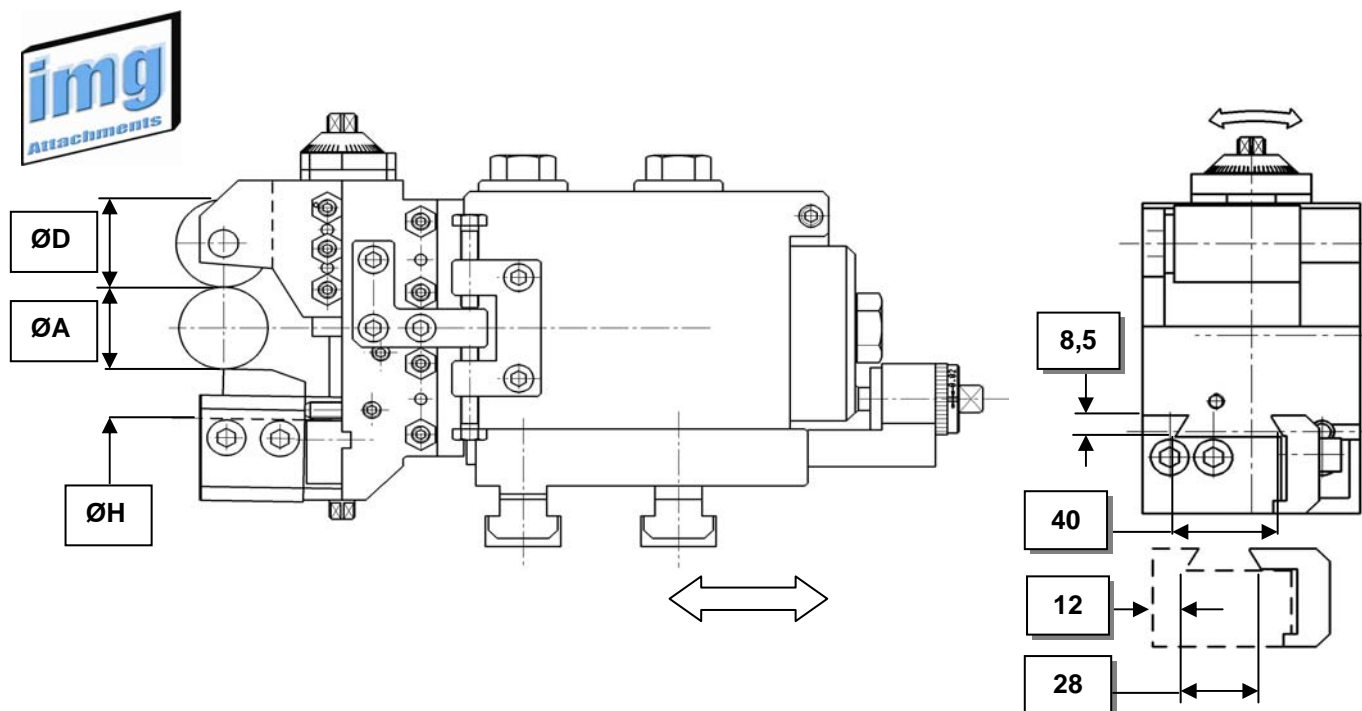

ACME GRIDLEY

MODELLO					CALIBRATORE SHAVING N°
MODEL	POS.	A MAX	D MAX	H	
9/16" RA6 - 1" RA6	2 CON PONTE IMG-WITH BRIDGE IMG	25	30	27,5-A/2	A180400
1"1/4 RA6 - 1"1/4 RB8 - 1"5/8 RBN8	2 CON PONTE IMG-WITH BRIDGE IMG	34	32	33-A/2	A180200
1"5/8 RB6 - 2"RB6	2 CON PONTE IMG-WITH BRIDGE IMG	50	32	43-A/2	A181000

NEW BRITAIN

MODELLO					CALIBRATORE SHAVING N°
MODEL	POS.	A MAX	D MAX	H	
MOD. 62	3-4-5	50	40	33-A/2	7612700
MOD. 60	3-4	22	30	20,5-A/2	763400
MOD. 60	3-4	26	34	23-A/2	762500-1
MOD. 51-MOD.52	3-4-5	22	30	20,5-A/2	763400
MOD. 51-MOD.52	3-4-5	26	34	23-A/2	762500-1
MOD. 51-MOD.52	3-4-5	34	32	33-A/2	7610000

CALBRATORI-SHAVING TOOLHOLDERS (SIZING)



DAVENPORT

n°7613000

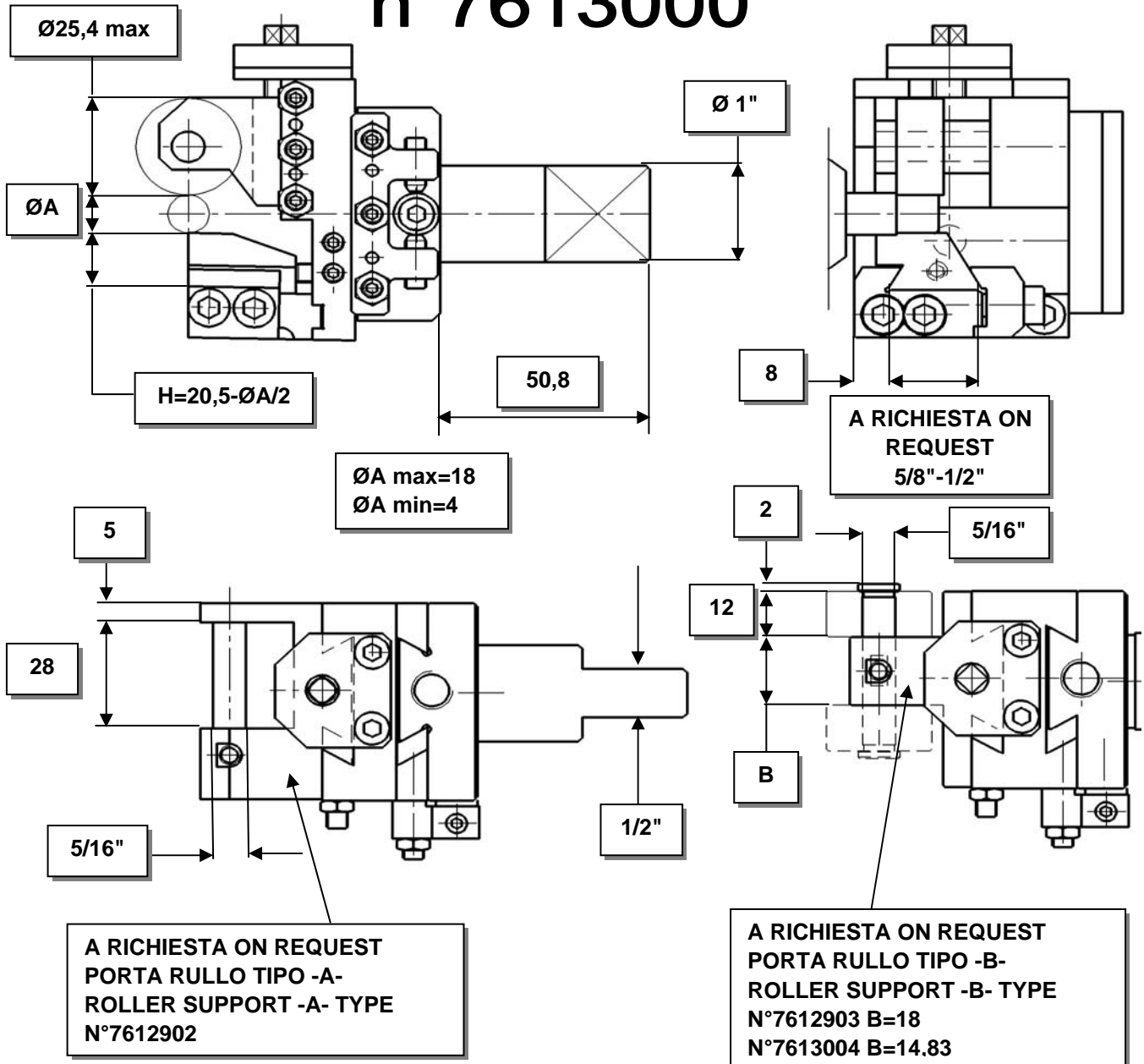

SPECIFICARE TIPO DI PORTA RULLO E ATTACCO UTENSILE
 SPECIFY ROLLER SUPPORT AND TOOL HOLDER SHANK

DISPOSITIVO COMANDO ASSIALE TESTINA PER RECESSI PUSH TYPE RECESSING SLIDE

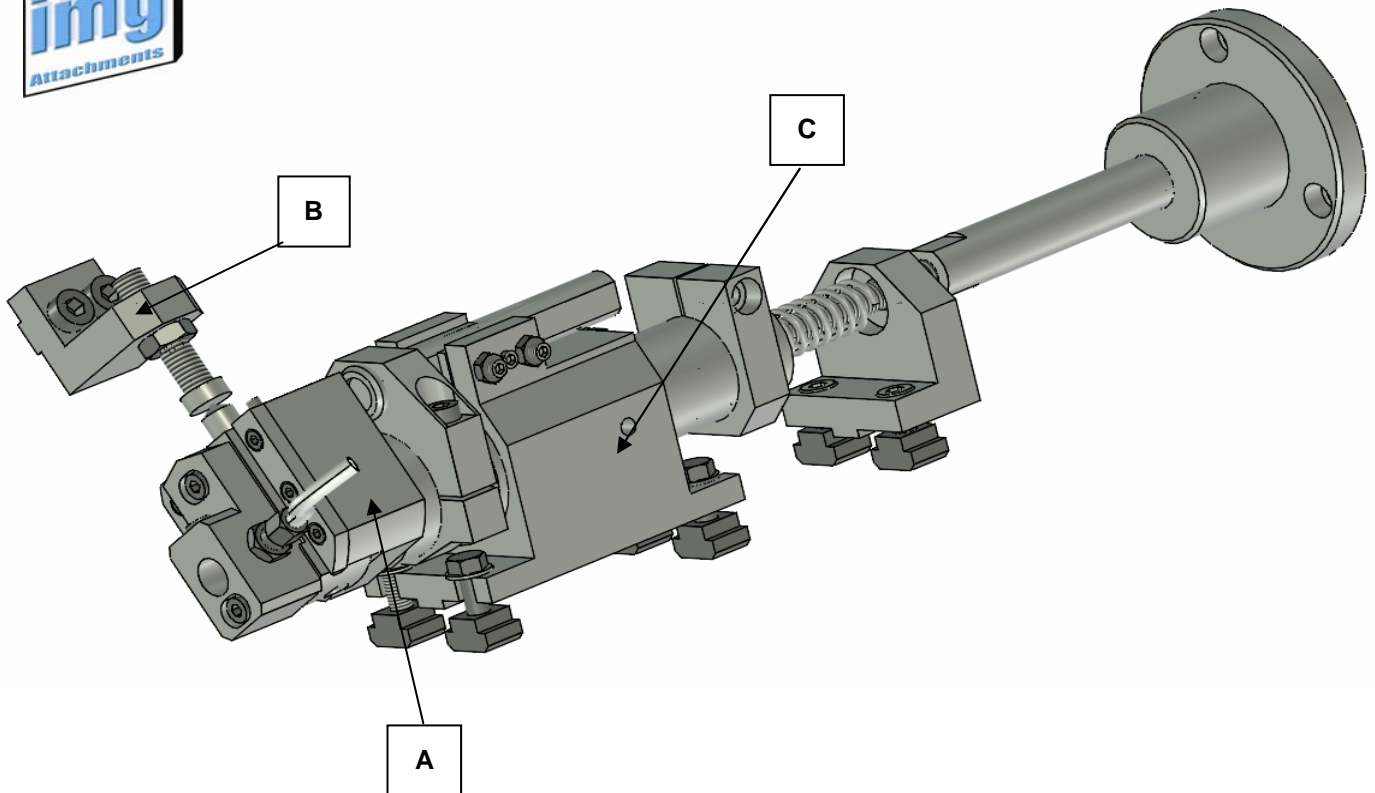

ACME GRIDLEY

MODELLO	TESTINA PER RECESSI -A-	SPINTORE-B-	COMANDO -C-
MODEL	RECESSING HEAD -A-	PUSH UNIT-B-	SLIDE -C-
1" RA6	951400	9512300	9512200
1 1/4 RA6	951200	959000	957800

TESTINA PER RECESSI A RAMPA RAMP TYPE RECESSING

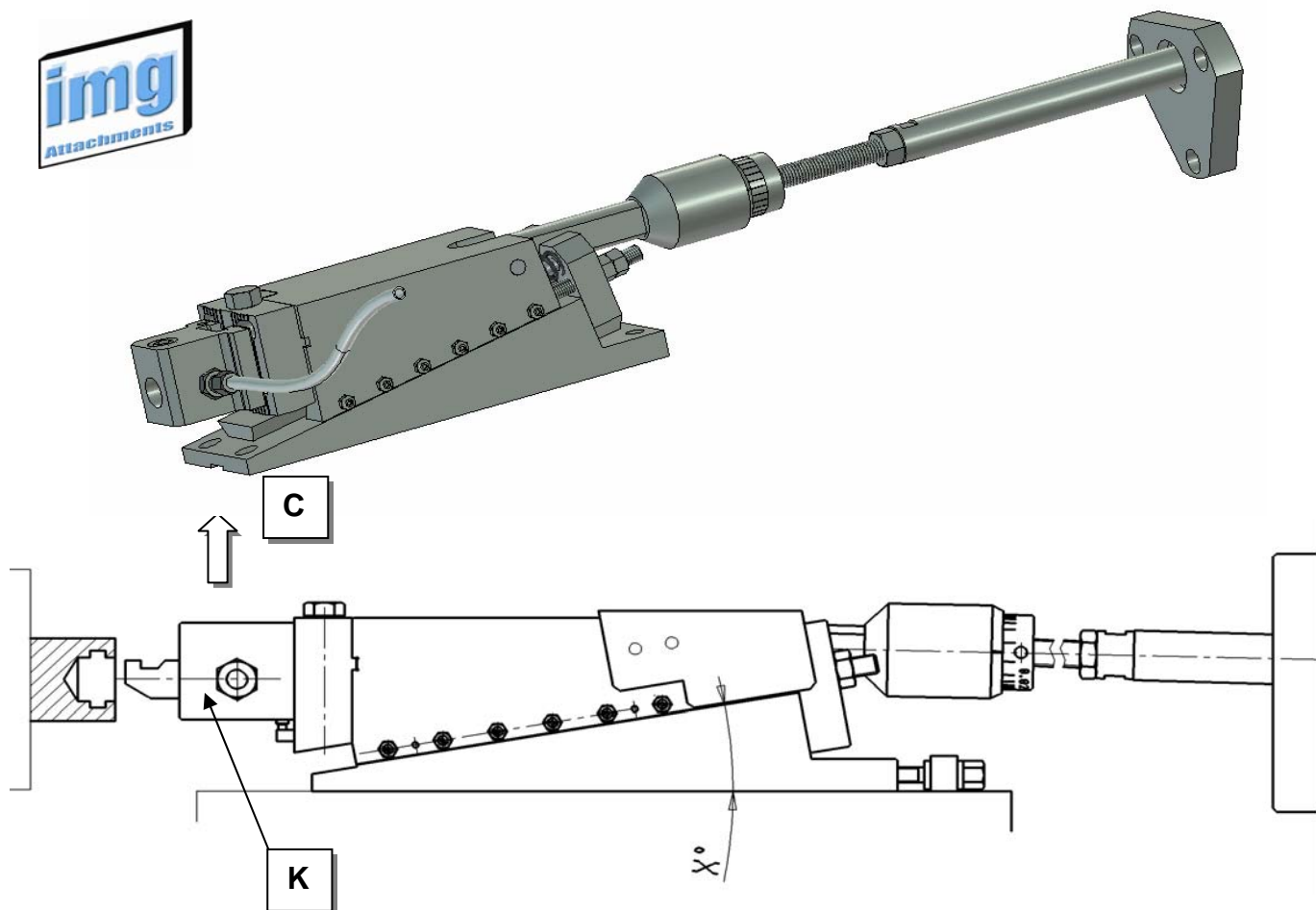

ACME GRIDLEY

MODELLO	pos.	C	X°	GRUPPO COMPLETO	PORTA UTENSILE -K- TOOLHOLDER -K-					
MODEL				COMPLETE UNIT	Ø10	Ø14	Ø16	Ø18	Ø20	Ø25
1" RA6	2.....5	4,5	8°	0089300		*	*		*	
1"5/8 RB6-2"RB6	2.....5	8	8°	0087200			*		*	*
1"5/8 RB8-2"RB8	2.....7	8	8°	0087100			*		*	*
1"1/4 RA6	2.....5	8	8°	0087400			*		*	*

PITTLER

MODELLO	pos.	C	X°	GRUPPO COMPLETO	PORTA UTENSILE -K- TOOLHOLDER -K-					
MODEL				COMPLETE UNIT	Ø10	Ø14	Ø16	Ø18	Ø20	Ø25
PRC 32/6-PRB 32/6	2.....5	7	5°42'	0080500				*	*	*
PRB 25/8	2.....7	14	10°	0083700					*	*
PRC 32/8	2.....5	10	10°	00810800			*		*	*
PRC 130/8	2.....7	6	7°	0088600			*		*	*

NEW BRITAIN

MOD.51	2.....5	7	7°	0084500				*	*	*
MOD.52	2.....5	9	10°	0087700				*	*	*
MOD.62	2.....5	9	10°	0087800				*	*	*

RECESSITORE ROTANTE A RAMPA RAMP ROTARY RECESSING ATT.

Gruppo particolarmente adatto per lavorazioni interne di materiali a truciolo lungo.
L'espulsione del truciolo viene aiutata dalla sua frantumazione data dalla fresa.
Suitable for internal machining with long chip material. Chip expulsion is facilitated by crushing.

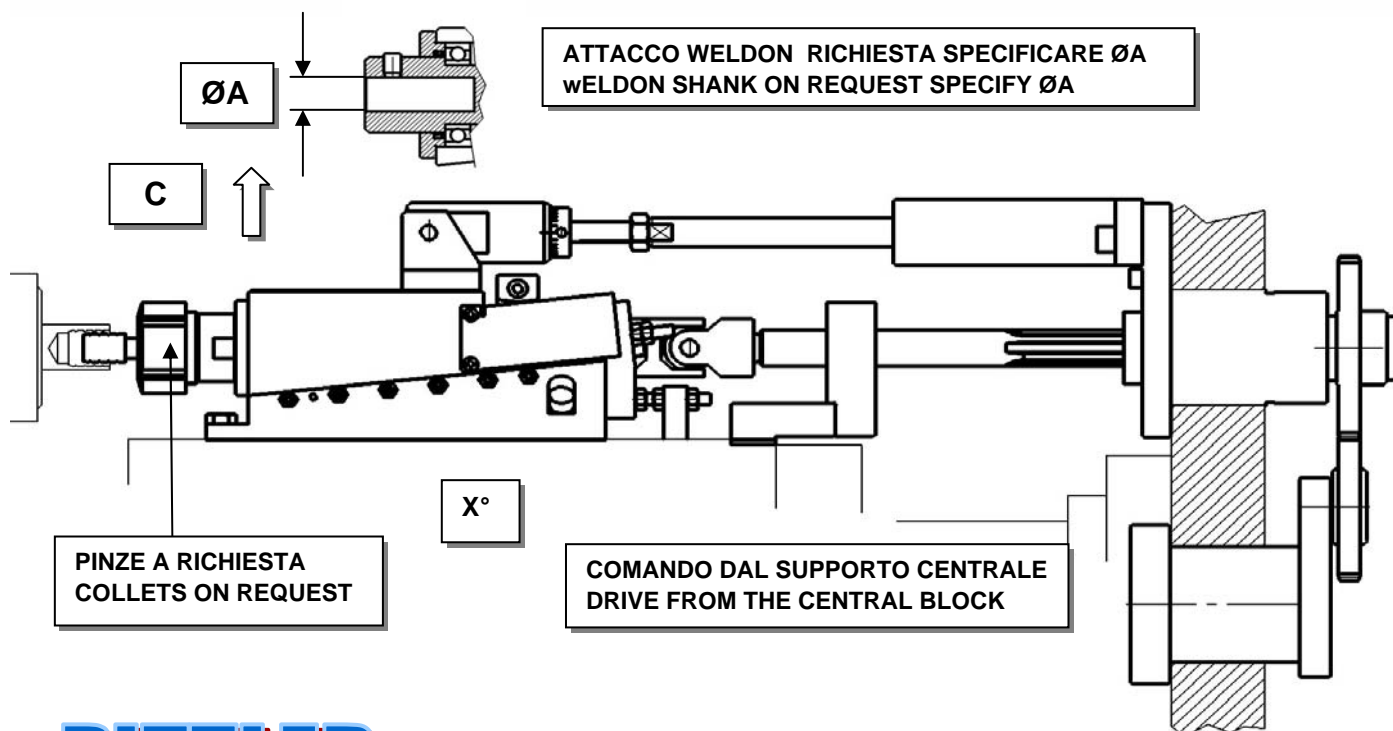
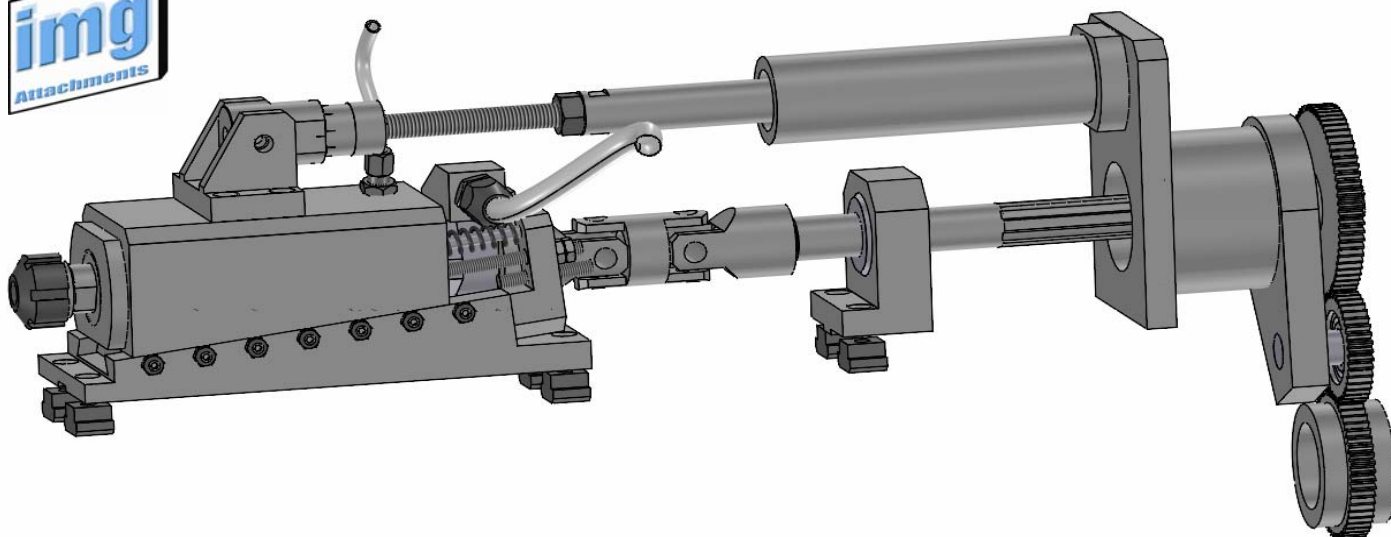

PITTLER

MODELLO MODEL	X°	C	GRUPPO COMPLETO COMPLETE UNIT	PINZE COLLETS
PRC 32/8	6°	5,50	A319100	ER32-ER40- $\varnothing A20$ - $\varnothing A10$

IL GRUPPO E' FORNITO CON UN RAPPORTO DI TRASMISSIONE A RICHIESTA 1,6-1,75-2
UNIT IS SUPPLIED WITH RATIO ON REQUEST 1,6-1,75-2



BROCCIATORE BROACHING ATT.

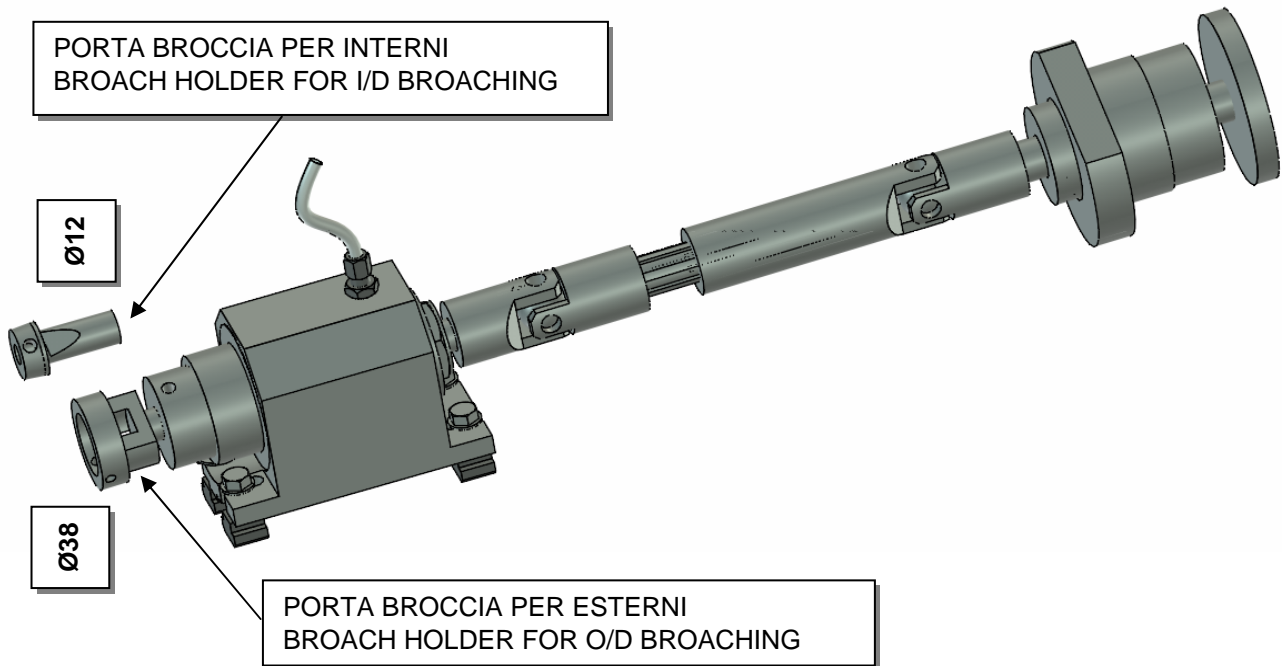

INCLUSO PORTA BROCCIA PER ESTERNI O PER INTERNI
DISPOSITIVO DI ALLINEAMENTO A RICHIESTA N°0050600
ALIGNMENT ATTACHMENT ON REQUEST N°0050600

ACME GRIDLEY

MODELLO MODEL	GRUPPO N° GROUP N°
1"1/4 RB8	0050900

PITTLER

MODELLO MODEL	GRUPPO N° GROUP N°
PRC 160/8	0050400

POLIGONALE FRESA FILETTI FLAT GENERATING, THREAD MILLING.



ACME GRIDLEY

1"RA6 POS.3-4

dis.n°825400 PER POLIGONALE-FOR FLAT GENERATING
dis.n°825800 PER FRESA FILETTI-FOR THREAD MILLING

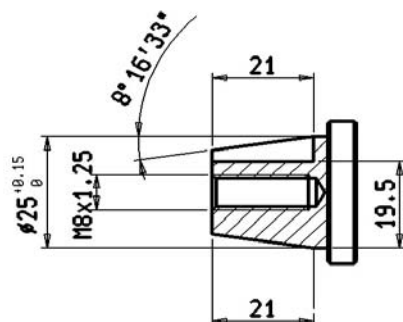
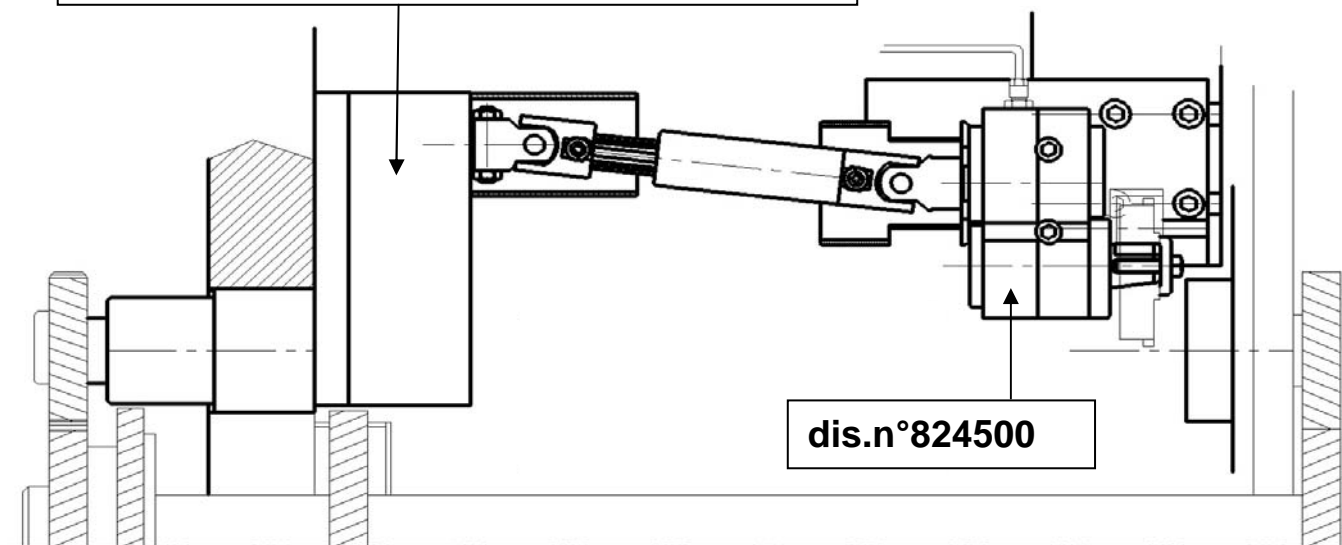

IL GRUPPO E' FORNITO SENZA LA RUOTA CENTRALE
UNIT IS SUPPLIED WITHOUT CENTRE DRIVING GEAR

DISPOSITIVO DI ALLINEAMENTO A RICHIESTA N°0050600
ALIGNMENT ATTACHMENT ON REQUEST N°0050600

POLIGONALE FRESA FILETTI FLAT GENERATING, THREAD MILLING.



ACME GRIDLEY

1 1/4" RA6 POS.3-4

DIS.N° 823500

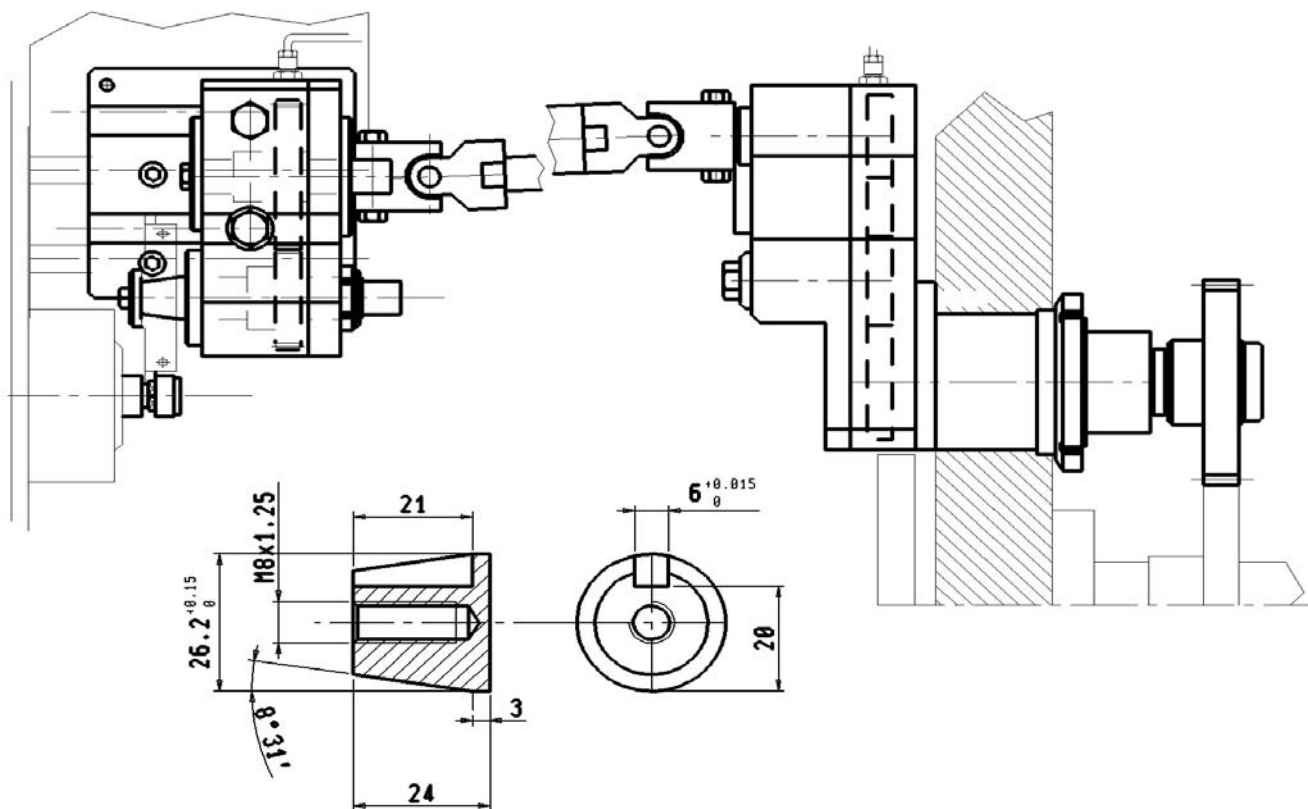

DISPOSITIVO DI ALLINEAMENTO A RICHIESTA N°0050600
ALIGNMENT ATTACHMENT ON REQUEST N°0050600

IL GRUPPO E' FORNITO SENZA LA RUOTA CENTRALE
UNIT IS SUPPLIED WITHOUT CENTRE DRIVING GEAR

IL GRUPPO E' PREDISPOSTO CON RUOTE PER POLIGONALE O FRESA FILETTI
THE UNIT WITH A SET OF GEARS FOR FLAT GENERATING OR THREAD MILLING

POLIGONALE FRESA FILETTI FLAT GENERATING, THREAD MILLING.



ACME GRIDLEY

1 5/8" MRBN8 POS.6

DIS.N° 829400

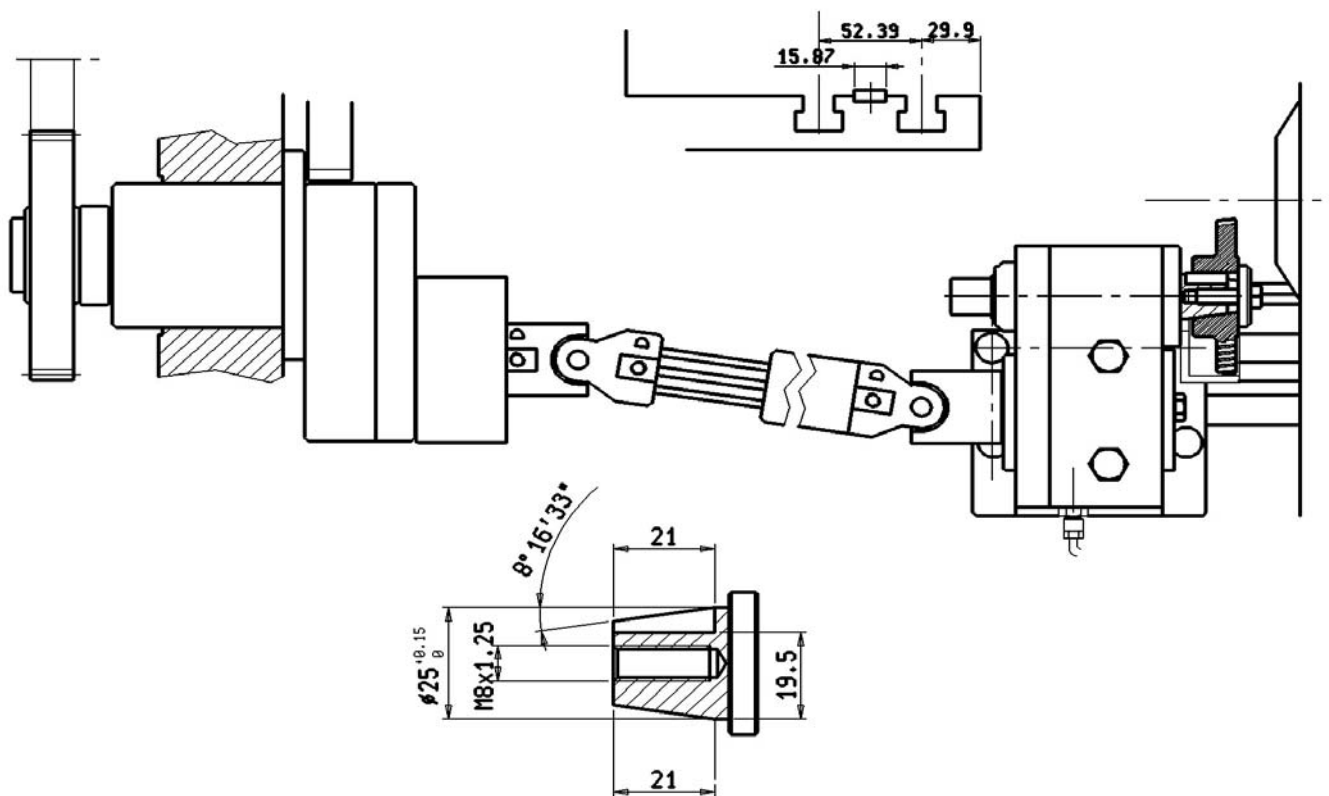

DISPOSITIVO DI ALLINEAMENTO A RICHIESTA N°0050600
ALIGNMENT ATTACHMENT ON REQUEST N°0050600

IL GRUPPO E' FORNITO SENZA LA RUOTA CENTRALE
UNIT IS SUPPLIED WITHOUT CENTRE DRIVING GEAR

IL GRUPPO E' PREDISPOSTO CON RUOTE PER POLIGONALE O FRESA FILETTI
THE UNIT WITH A SET OF GEARS FOR FLAT GENERATING OR THREAD MILLING

POLIGONALE FRESA FILETTI E INTAGLI VARI FLAT GENERATING, THREAD MILLING AND BALL SLOTS.



NEW BRITAIN

MOD. 51 POS. 2-3-4 DIS.N°821400-1

MOD. 52 POS. 2-3-4 DIS.N°823400

MOD. 60 POS. 3-4 DIS.N°823600

MOD. 62 POS. 2-3-4 DIS.N°823300

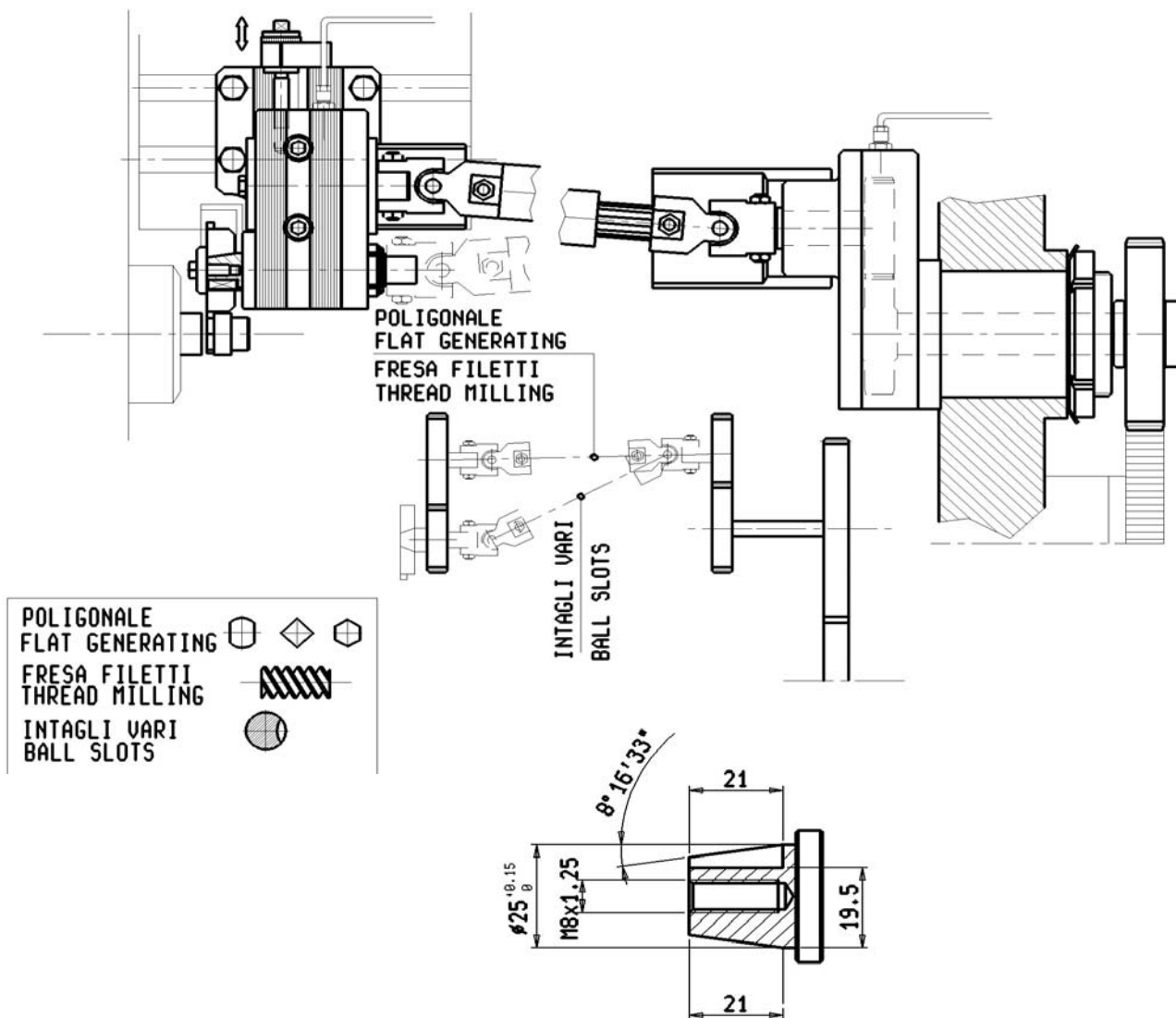

DISPOSITIVO DI ALLINEAMENTO A RICHIESTA N°0050600
ALIGNMENT ATTACHMENT ON REQUEST N°0050600

IL GRUPPO E' FORNITO SENZA LA RUOTA CENTRALE
UNIT IS SUPPLIED WITHOUT CENTRE DRIVING GEAR

IL GRUPPO E' PREDISPOSTO CON RUOTE PER POLIGONALE O FRESA FILETTI
THE UNIT WITH A SET OF GEARS FOR FLAT GENERATING OR THREAD MILLING

FRESA FILETTI - THREAD MILLING



NEW BRITAIN

MOD. 62 POS. 3-4 DIS.N°829200

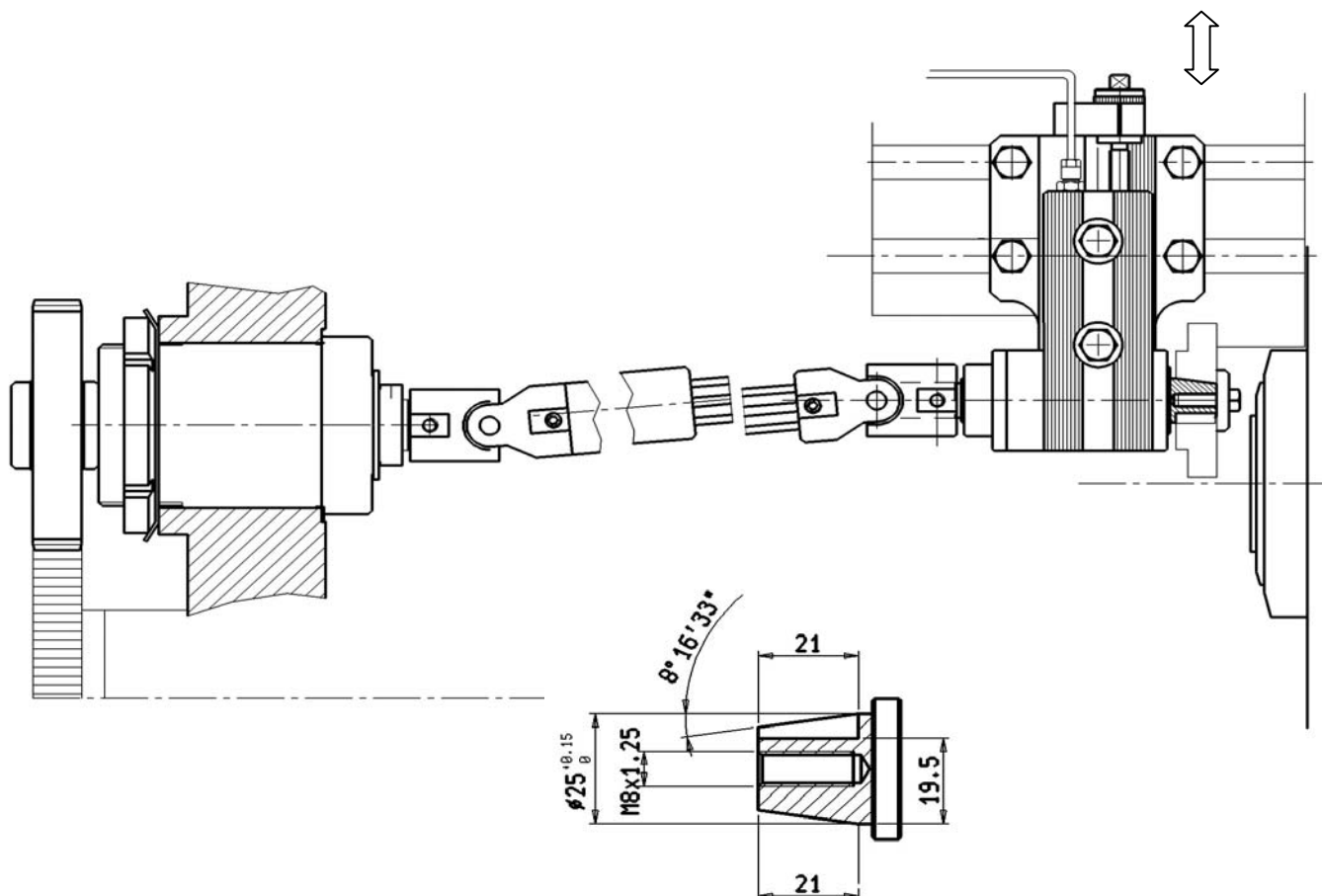

DISPOSITIVO DI ALLINEAMENTO A RICHIESTA N°0050600
ALIGNMENT ATTACHMENT ON REQUEST N°0050600

IL GRUPPO E' FORNITO SENZA LA RUOTA CENTRALE
UNIT IS SUPPLIED WITHOUT CENTRE DRIVING GEAR

GRUPPO SLITTA PER POLIGONATURE IN PASSATA FLAT GENERATING ATT.SLIDE FOR AXIAL TRAVEL



NEW BRITAIN

MOD. 52 POS. 2 DIS.N°827200-1

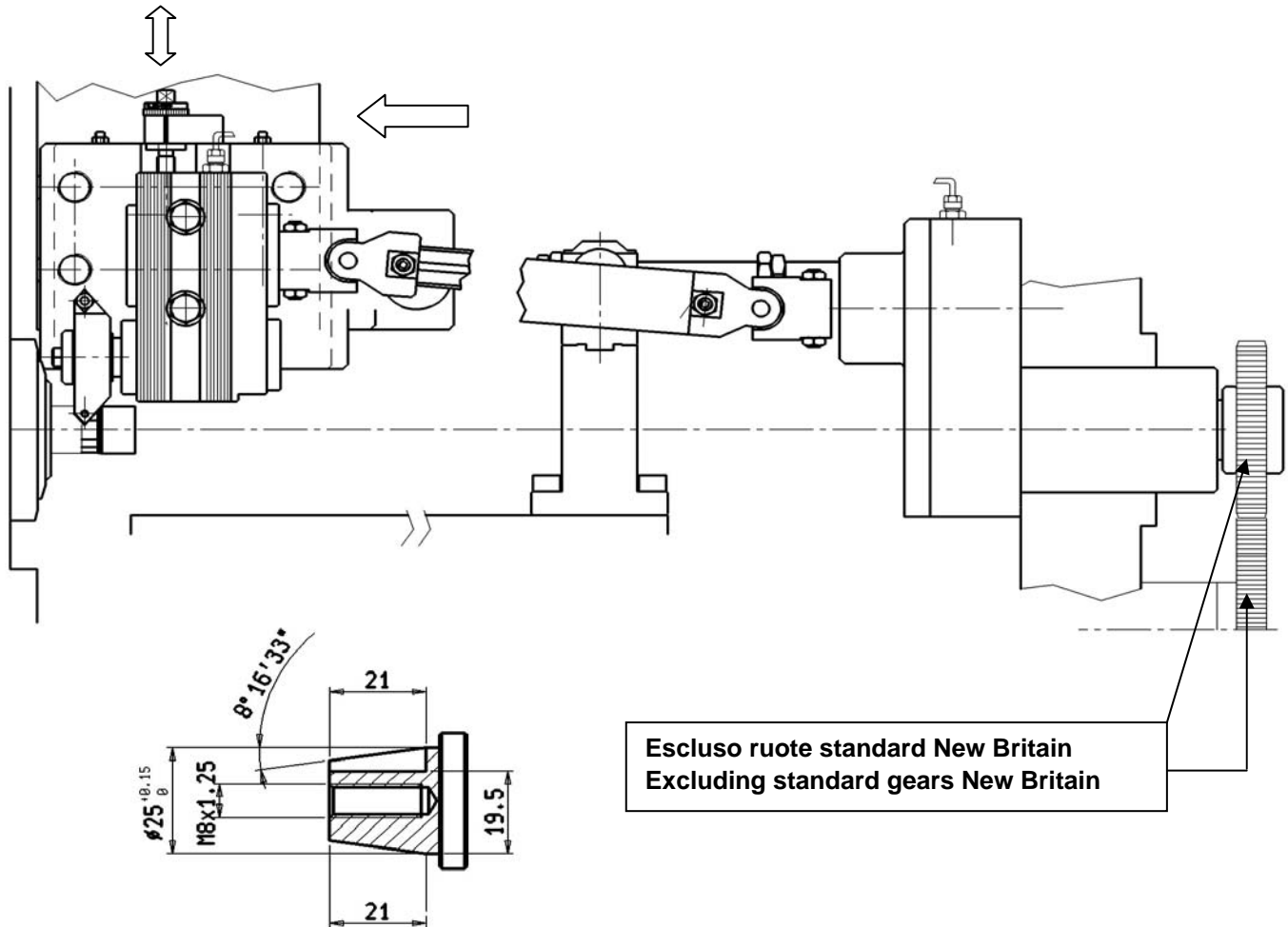

DISPOSITIVO DI ALLINEAMENTO A RICHIESTA N°0050600
ALIGNMENT ATTACHMENT ON REQUEST N°0050600

IL GRUPPO E' FORNITO SENZA LA RUOTA CENTRALE
UNIT IS SUPPLIED WITHOUT CENTRE DRIVING GEAR

GRUPPO SPACCO SFERA BALL SLOTS UNIT



NEW BRITAIN

MOD. 62 POS. 4 DIS.N°825500

MOD. 627 POS. 4 DIS.N°824700

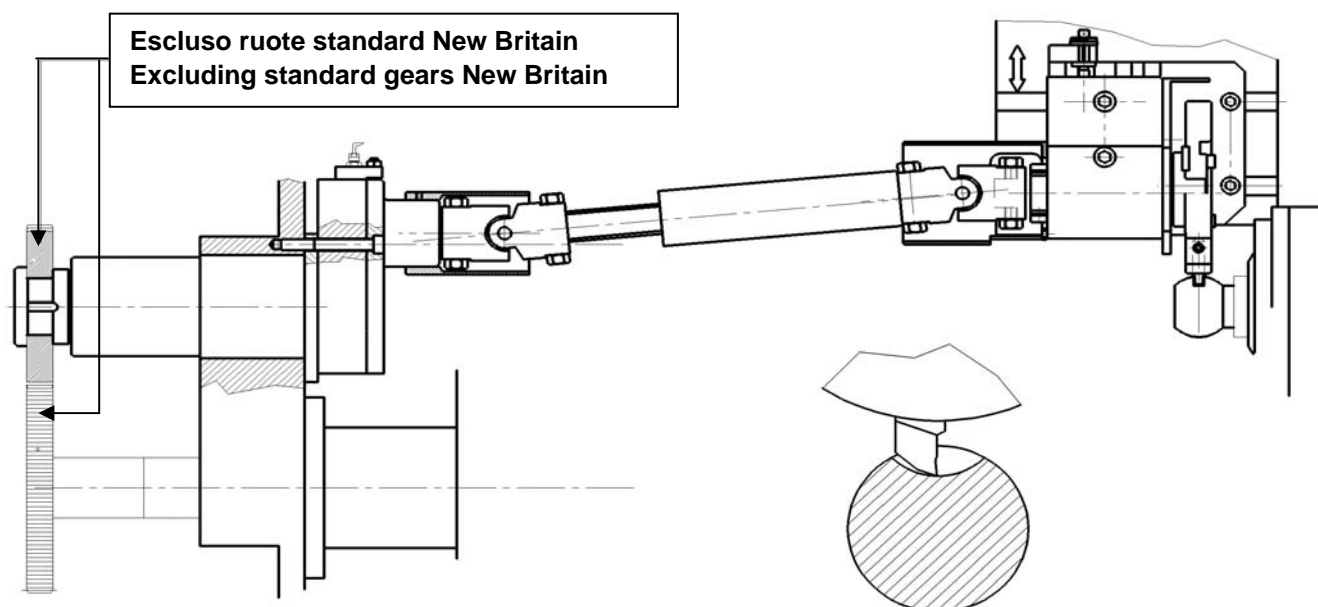

DISPOSITIVO DI ALLINEAMENTO A RICHIESTA N°0050600
ALIGNMENT ATTACHMENT ON REQUEST N°0050600

IL GRUPPO E' FORNITO SENZA LA RUOTA CENTRALE
UNIT IS SUPPLIED WITHOUT CENTRE DRIVING GEAR



MARCATORI MARKING ATTACH.

N°750100

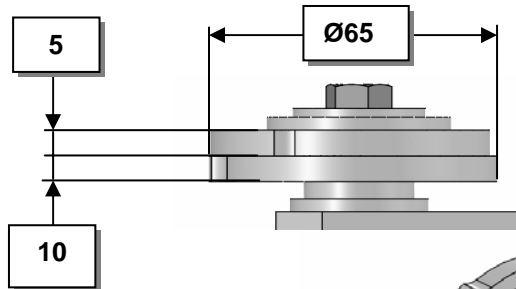

**TRASCINATORE DRIVER
750115**

**RULLO CON CARATTERI
INCISI A RICHIESTA-
MARKING ROLL ON
REQUEST**

H=2 per 145° quantità n°29
 H=2,5 per 145° quantità n°29
 H=3 per 145° quantità n°27
 H=4 per 145° quantità n°16
 H=2 by 145° quantity n°29
 H=2,5 by 145° quantity n°29
 H=3 by 145° quantity n°27
 H=4 by 145° quantity n°16

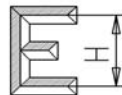

Rullo porta caratteri
 con inserti intercambiabili
 n°756800 X°=145°
 Marking roll with
 interchangeable characters
 n°756800 X°=145°

ADATTATORE-ADAPTOR

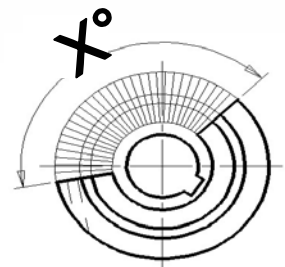

ACME GRIDLEY

MODELLO MODEL	ADATTATORE ADAPTOR	TRASCINATORE DRIVER
1"1/4 RA6 POS.3-4	755600	750115
1"1/4 RB8;1"5/8 RBN8	755600	750115

PITTLER

MODELLO MODEL	ADATTATORE ADAPTOR	TRASCINATORE DRIVER
PRC 32/8;PRC 32/6;PRCB 32/6	757500	750115

MARCATORI CON RICARICA MARKING ROLLS WITH RE-SETTING SYSTEM



RULLO INTEGRALE CON
CARATTERI INCISI A
RICHIESTA-MARKING
ROLL ON REQUEST

ricarica durante il ritorno del carrello
reloaded during bsck stroke

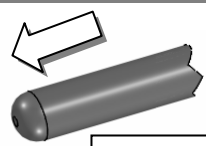

spintore escluso
applicazione a cura del
cliente.push excluding

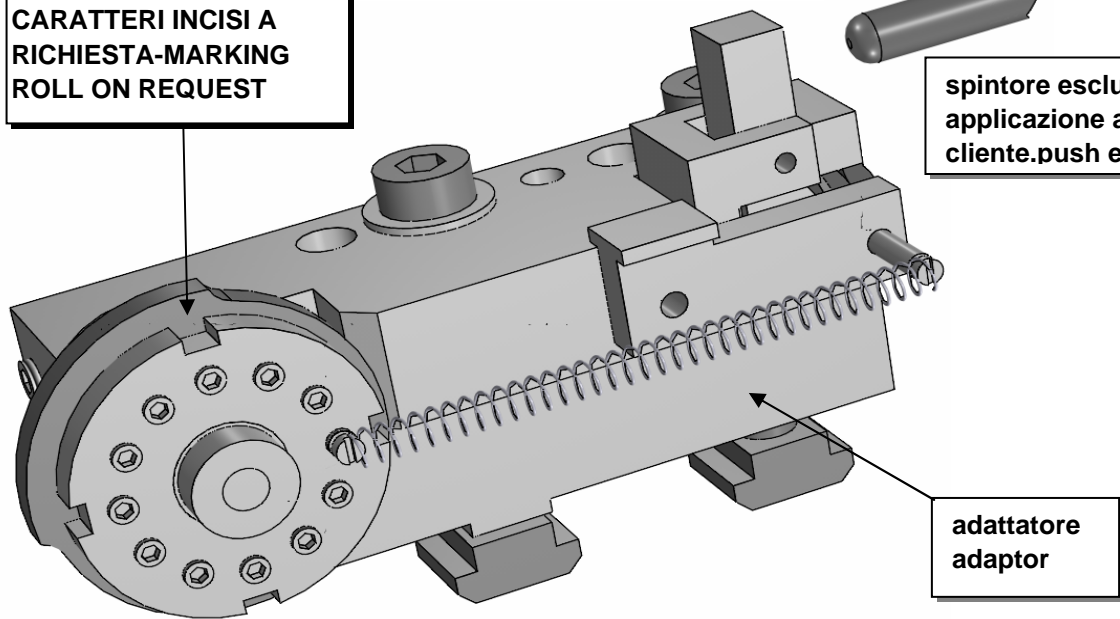

adattatore
adaptor

n° 756100

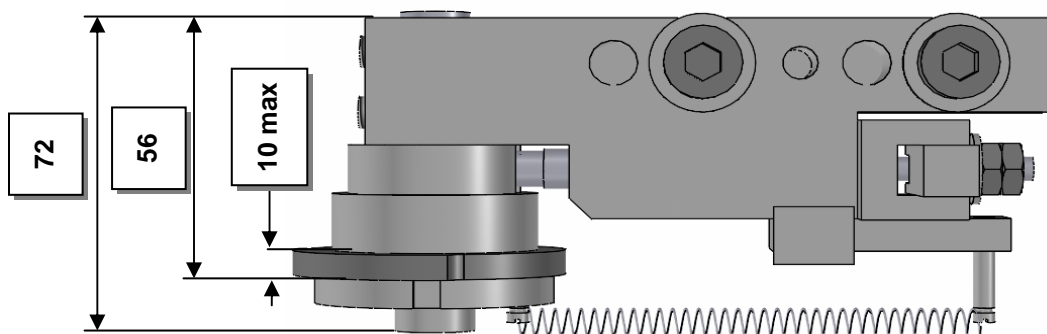

MARCATORI CON RICARICA MARKING ROLLS WITH RE-SETTING SYSTEM

ACME GRIDLEY

MODELLO MODEL	POS.	MARCATORE MARKER	ADATTATORE ADAPTOR
1 1/4" RA6	3-4	756100	757100 REGOLABILE- ADJUSTABLE
1 1/4" RA8;1 5/8" RBN8	1-3-4-5- 6-8	756100	757100 REGOLABILE- ADJUSTABLE
2 5/8" RB6	1-3-4-5- 6-8	756100	756600 REGOLABILE- ADJUSTABLE

PITTLER

MODELLO MODEL	POS.	MARCATORE MARKER	ADATTATORE ADAPTOR
PRC 32/8;PRC 32/6;PRCB 32/6	3-4	756100	757200 REGOLABILE- ADJUSTABLE

MARCATORI CON RICARICA MARKING ROLLS WITH RE-SETTING SYSTEM



ricarica durante il ritorno del carrello
reloaded during bsck stroke

756800
RULLO MARCATORE CON
CARATTERI INTERCAMBIABILI
A RICHIESTA
MARKING ROLL WITH
INTECHANGEABLE ON
REQUEST

spintore escluso
applicazione a cura del
cliente.push excluding

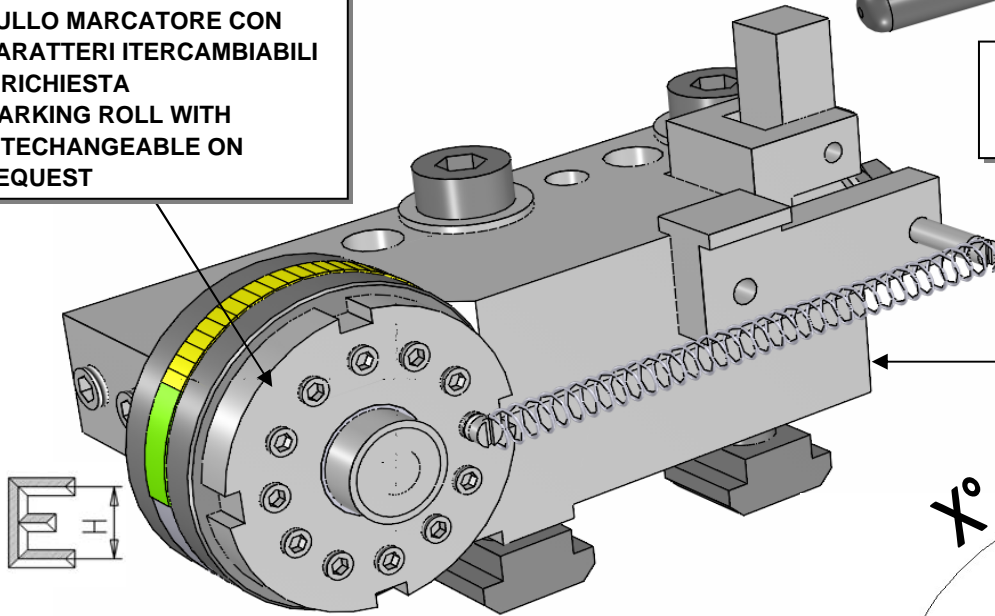

adattatore
adaptor

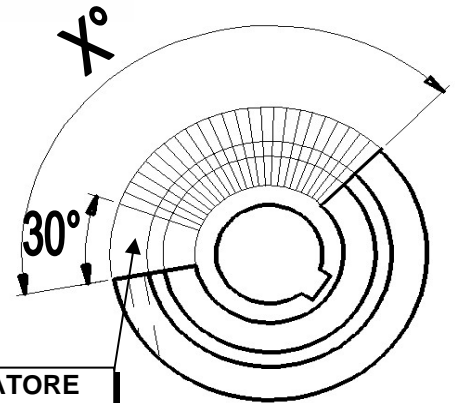
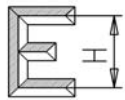

TRASCINATORE
DRIVER 755903

H=2 X°=145° quantità n°29 X°=115° quantità n°23
H=2,5 X°=145° quantità n°29 X°=115° quantità n°23
H=3 ;X°=145° quantità n°27 X°=115° quantità n°21
H=4 X°=145° quantità n°16 X°=115° quantità n°12
H=2 X°=145° quantity n°29 X°=115° quantity n°23
H=2,5 X°=145° quantity n°29 X°=115° quantity n°23
H=3 X°=145° quantity n°27 X°=115° quantity n°21
H=4 X°=145° quantity n°16 X°=115° quantity n°12

n° 755900

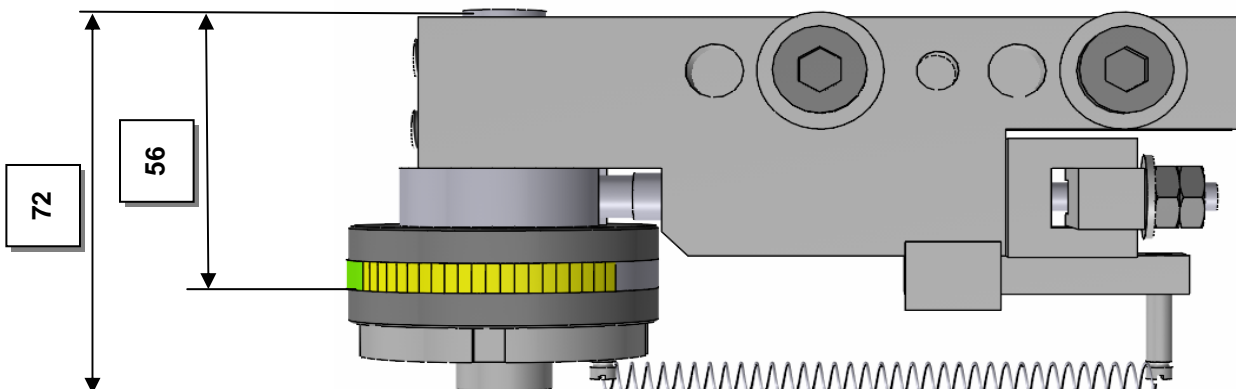

MARCATORI CON RICARICA MARKING ROLLS WITH RE-SETTING SYSTEM

ACME GRIDLEY

MODELLO MODEL	POS.	MARCATORE MARKER	ADATTATORE ADAPTOR
1 1/4" RA6	3-4	755900	757100 REGOLABILE- ADJUSTABLE
1 1/4" RA8;1 5/8" RBN8	1-3-4-5- 6-8	755900	757100 REGOLABILE- ADJUSTABLE
2 5/8" RB6	1-3-4-5- 6-8	755900	756600 REGOLABILE- ADJUSTABLE

PITTLER

MODELLO MODEL	POS.	MARCATORE MARKER	ADATTATORE ADAPTOR
PRC 32/8;PRC 32/6;PRCB 32/6	3-4	755900	757200 REGOLABILE- ADJUSTABLE
PRC 50/6	3-4	755900	756500 REGOLABILE- ADJUSTABLE

MARCATORI CON RICARICA

MARKING ROLLS WITH RE-SETTING SYSTEM

dis.n°7511100



spintore escluso
applicazione a cura del
cliente.push excluding

ricarica durante il ritorno del
carrello
reloaded during bsck stroke

ADATTATORE
ADAPTOR

756800
RULLO MARCATORE STANDARD
CON CARATTERI
INTERCAMBIABILI A RICHIESTA
MARKING ROLL STANDARD WITH
INTECHANGEABLE CHARACTERS
ON REQUEST

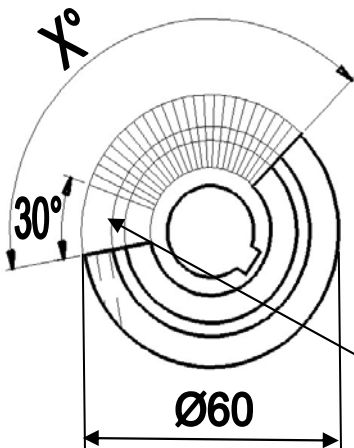
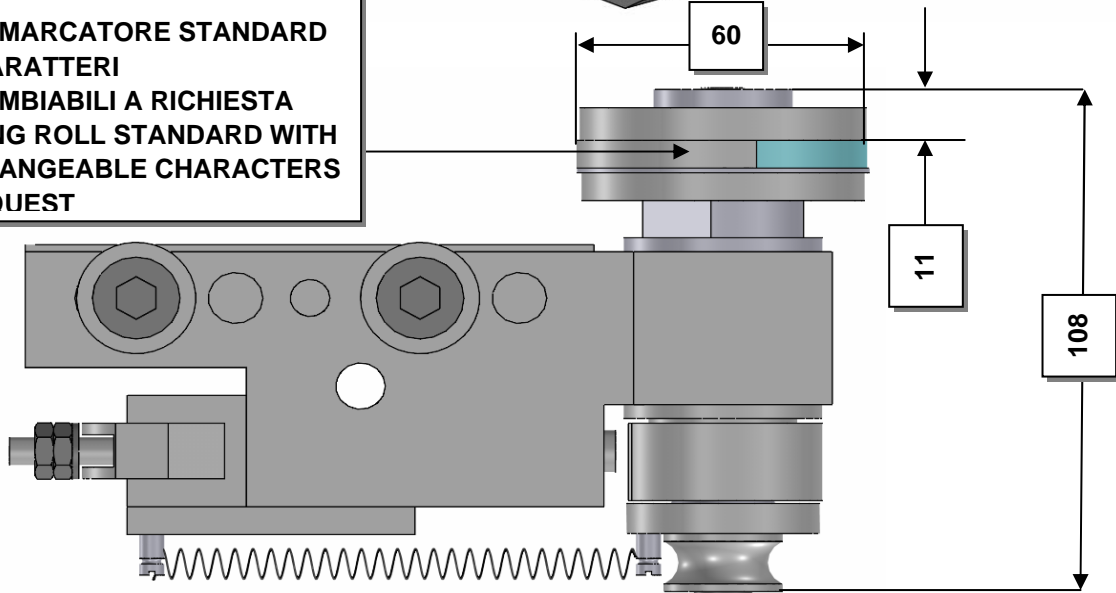

TRASCINATORE
DRIVER 755903

H=2 X°=145° quantità n°29 X°=115° quantità n°23
H=2,5 X°=145° quantità n°29 X°=115° quantità n°23
H=3 X°=145° quantità n°27 X°=115° quantità n°21
H=4 X°=145° quantità n°16 X°=115° quantità n°12
H=2 X°=145° quantity n°29 X°=115° quantity n°23
H=2,5 X°=145° quantity n°29 X°=115° quantity n°23
H=3 X°=145° quantity n°27 X°=115° quantity n°21
H=4 X°=145° quantity n°16 X°=115° quantity n°12

GRUPPO PORTA RULLO CON INSERTI STANDARD DIS.N°756800
TRASCINATORE DIS.N°755903

MARCATORI CON RICARICA

MARKING ROLLS WITH RE-SETTING SYSTEM

Variante al n° 7511100 con rullo speciale stretto a inserti standard

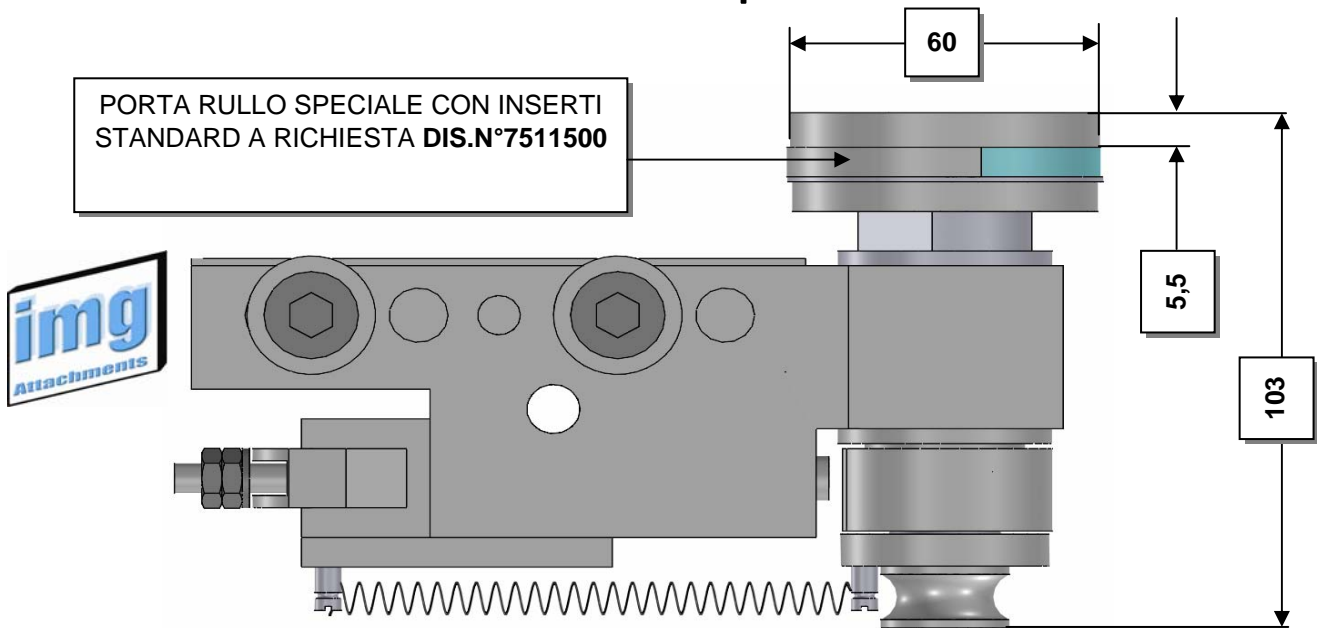

GRUPPO PORTA RULLO CON INSERTI STANDARD TIPO STRETTO DIS.N°7511500

Variante al n° 7511100 con rullo a inserti speciali stretto

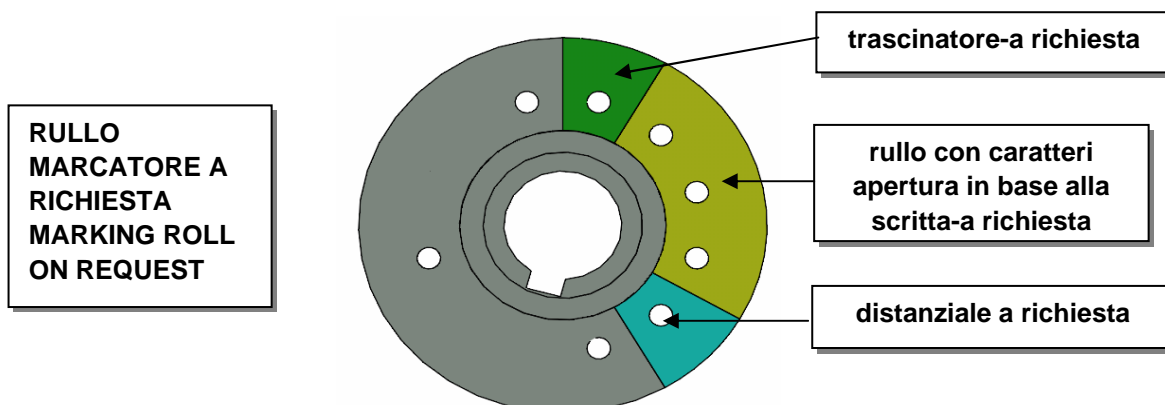
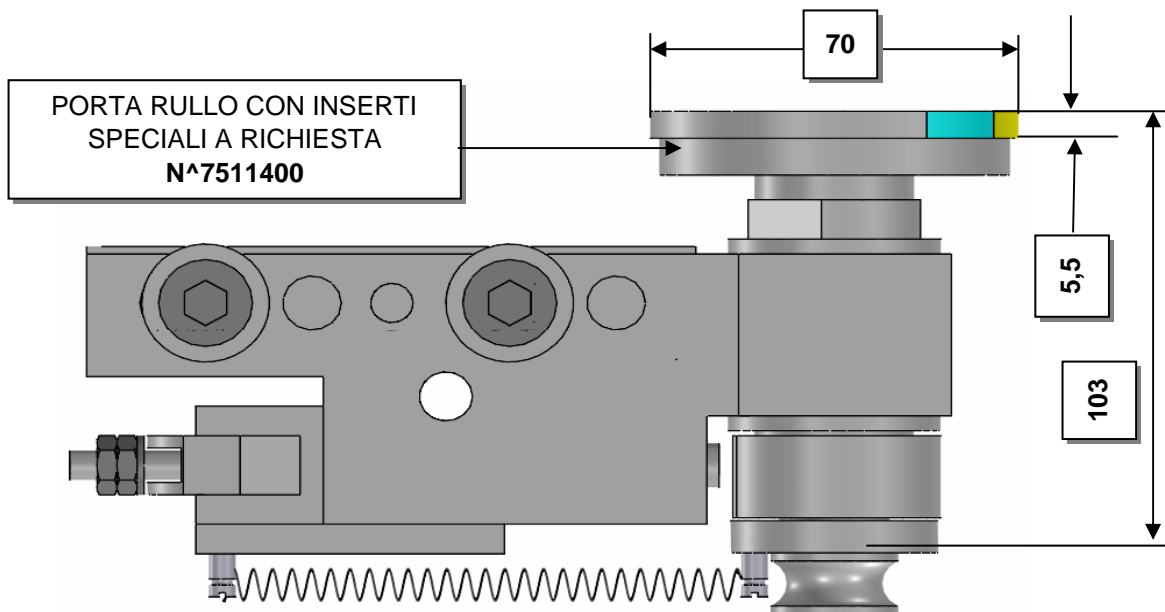

GRUPPO PORTA RULLO CON INSERTI SPECIALI TIPO STRETTO DIS.N°7511400

MARCATORI CON RICARICA MARKING ROLLS WITH RE-SETTING SYSTEM



n° 7511100 with special integral narrow roller

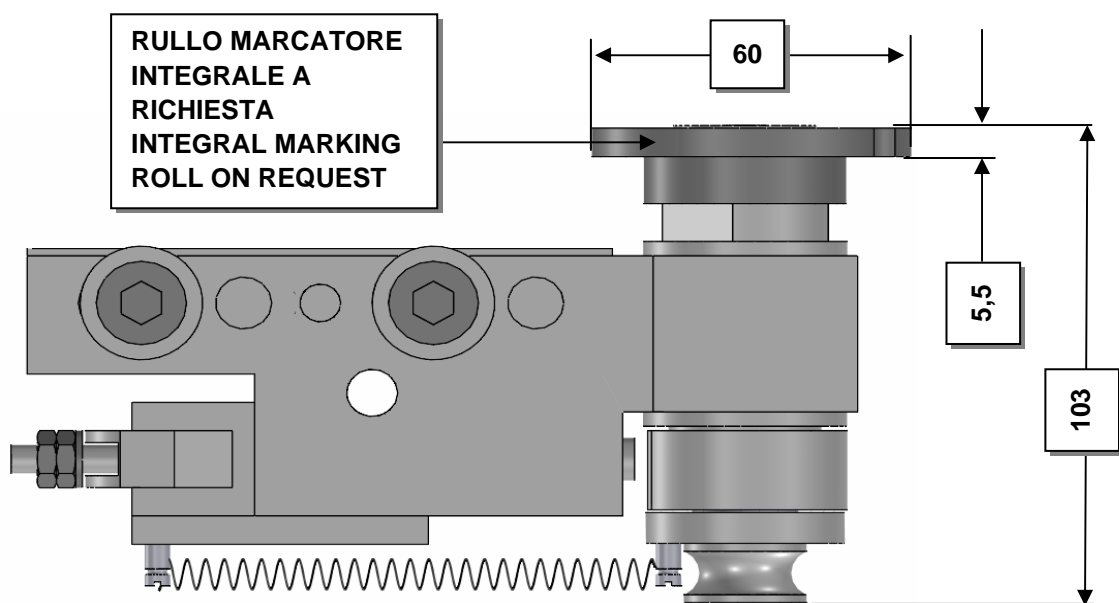

MARCATORI CON RICARICA MARKING ROLLS WITH RE-SETTING SYSTEM

ACME GRIDLEY

MODELLO MODEL	POS.	MARCATORE MARKER	ADATTATORE ADAPTOR
1 1/4" RA6	3-4	7511100	757100 REGOLABILE- ADJUSTABLE
1 1/4" RA8;1 5/8" RBN8	1-3-4-5- 6-8	7511100	757100 REGOLABILE- ADJUSTABLE
2 5/8" RB6	1-3-4-5- 6-8	7511100	756600 REGOLABILE- ADJUSTABLE

PITTLER

MODELLO MODEL	POS.	MARCATORE MARKER	ADATTATORE ADAPTOR
PRC 32/8;PRC 32/6;PRCB 32/6	3-4	7511100	757200 REGOLABILE- ADJUSTABLE

MARCATORI PER C.N.C. MARKING ATTACH. FOR C.N.C.

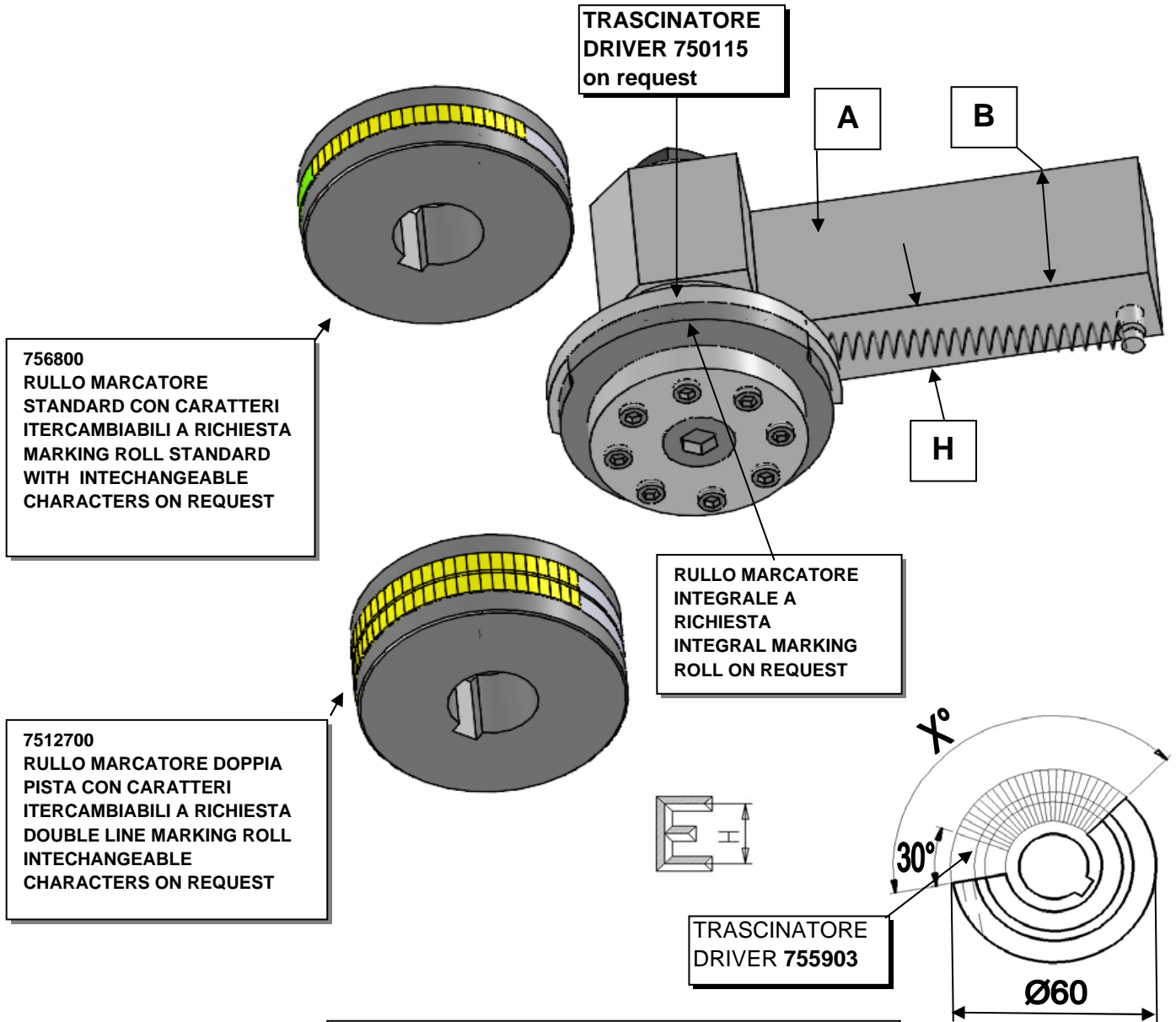

H=2 $X^\circ=145^\circ$ quantità n°29 $X^\circ=115^\circ$ quantità n°23
H=2,5 $X^\circ=145^\circ$ quantità n°29 $X^\circ=115^\circ$ quantità n°23
H=3 $X^\circ=145^\circ$ quantità n°27 $X^\circ=115^\circ$ quantità n°21
H=4 $X^\circ=145^\circ$ quantità n°16 $X^\circ=115^\circ$ quantità n°12
H=2 $X^\circ=145^\circ$ quantity n°29 $X^\circ=115^\circ$ quantity n°23
H=2,5 $X^\circ=145^\circ$ quantity n°29 $X^\circ=115^\circ$ quantity n°23
H=3 $X^\circ=145^\circ$ quantity n°27 $X^\circ=115^\circ$ quantity n°21
H=4 $X^\circ=145^\circ$ quantity n°16 $X^\circ=115^\circ$ quantity n°12

B	H	GRUPPO -A- GROUP -A-	RULLO MARCATORE MARKING ROLL MARKER	TRASCINATORE DRIVER
40	20	751400	756800	750115
40	25	751500	756800	750115
46	25	7512600	7512700	750115

RULLATORI E GODRONATORI BURNISHING AND KNURLING HOLDER

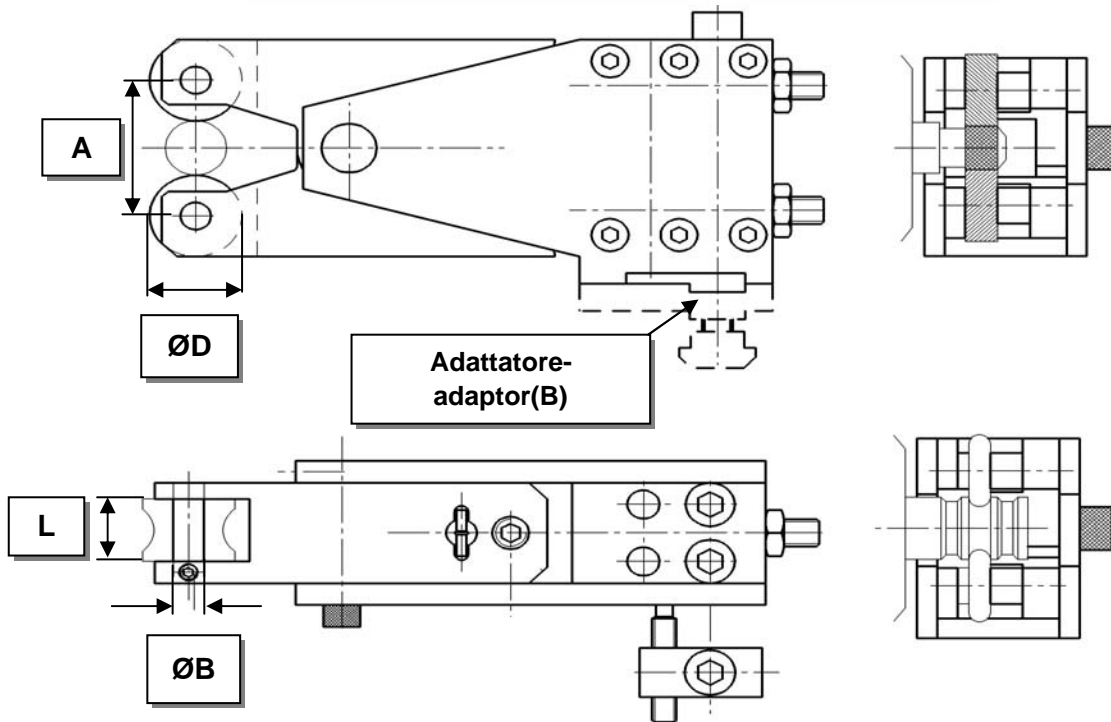
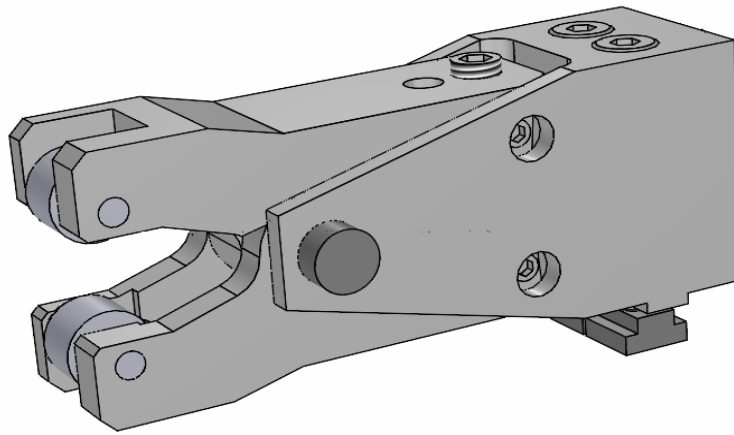

ACME GRIDLEY

MODELLO MODEL	GRUPPO GROUP	ADATTATORE (B) ADAPTOR (B)	A MAX	ØD MAX	ØB	L
9/16" RA6;1" RA6 POS.3-4	773700	-	40	23	6	16
1 1/4" RA6 POS.3-4	770400	776400	61	39	10	23
1 1/4" RB8 POS.3-4-5-6	770400	776400	61	39	10	23

PITTLER

MODELLO MODEL	GRUPPO GROUP	ADATTATORE (B) ADAPTOR (B)	A MAX	ØD MAX	ØB	L
PRC 25/8;PRC 32/8;PRC 32/6	770400	774300	61	39	10	23
PRC 50/6	773100	775400	104	55	10	32

RULLATORI E GODRONATORI BURNISHING AND KNURLING HOLDER



DAVENPORT N°7710500

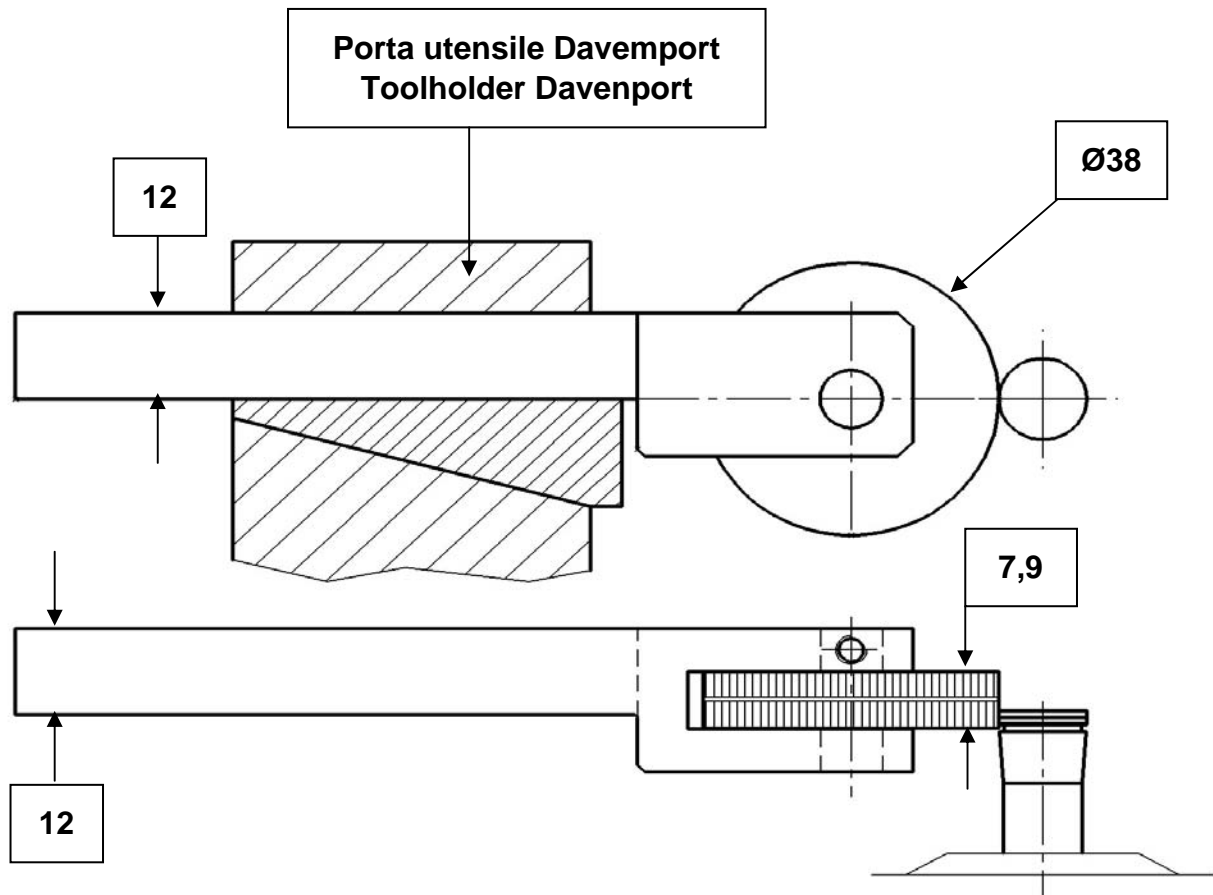

PORTA RULLI DI SOSTEGNO ROLLER STEADIES

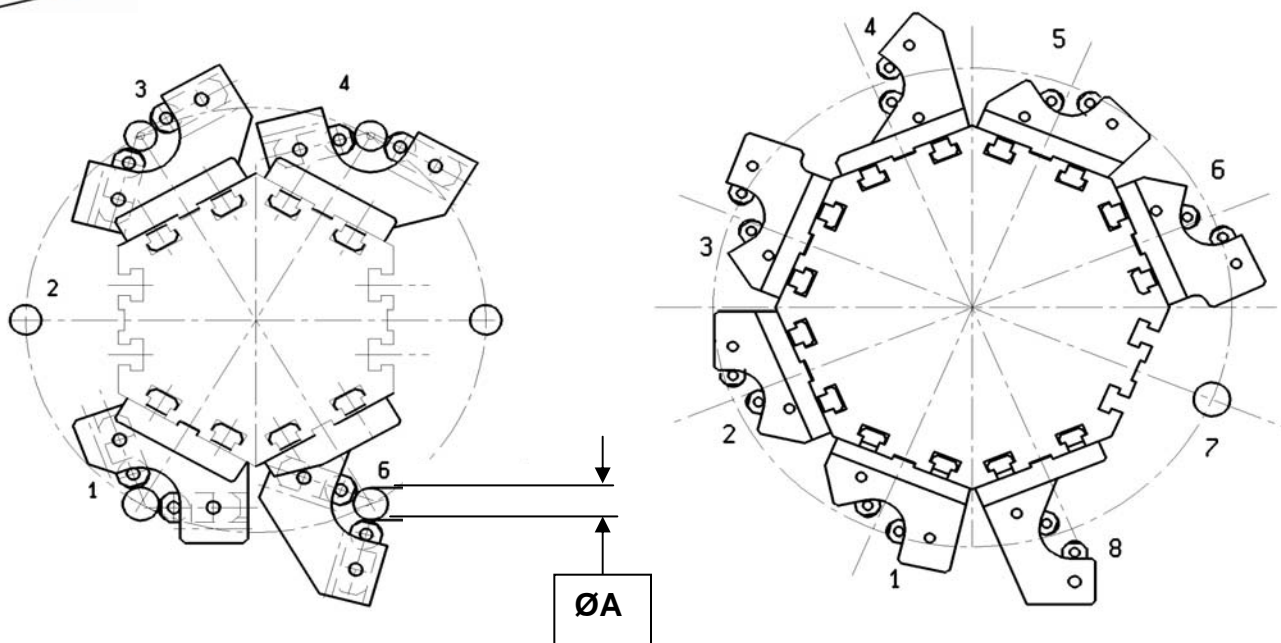

ACME GRIDLEY

MODELLO MODEL	GRUPPO GROUP	POS.	Ø A MAX	Ø A MAX
9/16"-1"	784900	1	18	6
	785100	3	18	6
	785200	4	18	6
	785300	6	18	6
1"1/4 RA6	784000	1	34	9
	783900	2-3	34	9
	784100	4-5	34	9
	783800	4-5	34	9
1"5/8 RB8	785400	1	36	10
	785500	2-5	36	10
	785600	3-6	36	10
	785700	4	36	10
	785800	8	36	10
1"1/4 RB8	784400	3	18	6
	785900	4	18	6
	784300	6	18	6

PITTLER

MODELLO MODEL	GRUPPO GROUP	POS.	Ø A MAX	Ø A MAX
PRC 25/8	784800	3	18	6
	781400	8	18	6
PRC 32/8	784400	3	32	7
	785900	4	32	7
	784300	6	18	6