

Thanks for buying our product!



# Instructions for Use and Assembly

for model Sledgehammer Freerider 5.3

Please read the instructions for proper assembly and use.

If anything in this document remains unclear please contact us via email, phone or by using the contact form on the website [www.sledgehammer.at](http://www.sledgehammer.at) or contact your local dealer.  
Please read this document carefully and you will get the best performance of our product.

## A) Scope of delivery

Frame, with mounted rear swing arm, fork, handle bar, stem, two skis packed by and the following parts:

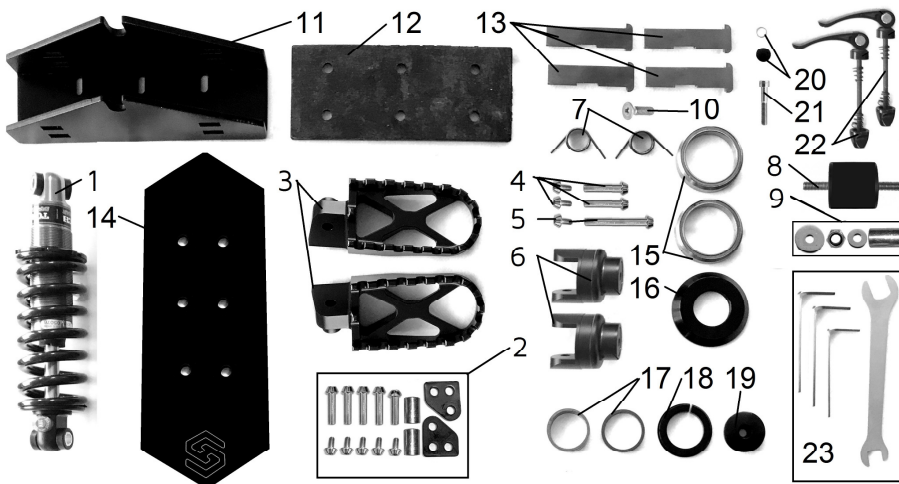

- (1) 2 shock absorbers ( with different springs 350 / 650 LBS)
- (2) misc. small parts for shock absorber mount [ 4 bolts 34mm + M6 screw, 1 bolt 24mm + M6 screw, 2 alloy sleeves 14mm long, shock adapter plates ]
- (3) 2 foot pegs (different - left and right!)
- (4) 2 bolts for foot pegs 38mm + M6 screw
- (5) 1 bolt for foot peg adapters 64mm + M6 screw
- (6) 2 foot peg adapters (different - left and right!)
- (7) 2 torque springs for foot pegs retention
- (8) 2 rubber cushions
- (9) 4 self locking nuts M8, 12 small washers, 2 large washers, 2 alloy sleeves 16mm
- (10) 12 Flat Head Bolts M6 x 15 mm
- (11) 2 adapter brackets for Ski
- (12) 1 rubber plate 4mm
- (13) 4 T-plates
- (14) 1 Edge Power Plate alloy 4mm thick
- (15) 2 roller bearings large
- (16) 1 top cap bearing
- (17) 1 Spacer for stem
- (18) 1 tapered center ring
- (19) 1 top cap for stem
- (20) 1 small washer and cap for pre load bolt
- (21) 1 pre load bolt M6 x 50mm
- (22) 2 Quick Release axles
- (23) misc. tools [ 2 Allen Key 5mm, 1 Allen Key 6mm, 1 Allen Key long 4mm, 1 open-end spanner 10/13 mm ]

## **B) Assembling your Skibike**

After unpacking all parts please follow the instructions in the sequence described. This will make the assembly easier.

### **1) Mounting the fork**

You will need the parts 15-21 and the stem according to the parts description on page 1 and the front fork. Please slide in one bearing (15) on to the lower end of the steering tube of the frame so that the tapered side is facing up into the lower head tube. See the symbolic drawing on the picture. Then slide the fork into the frame and make sure that the bearing slides into the frame. Please apply uniform pressure to make sure that the bearing slides in straight and doesn't twist. Then slide on the second bearing (15) on the top of the head tube so that the tapered section faces down into the head tube. Then put on the tapered center ring (18) with the wider side facing upwards and the top cap for the bearing (16). This might require some force because it has a seal inside. Then put both spacers (17) and the stem on. Finally the stem cap (19) and now screw in the bolt for the stem (21) and tighten it until there is no more play in between the bearings and the fork. Be cautious not to over tighten. Now check if the fork spins freely without any play. It should spin smoothly on the bearings. If not please loosen the bolt (21) on the stem a little. If you rattle on the fork and there is still play please tighten the bolt (21) a little more. See the correct arrangement:

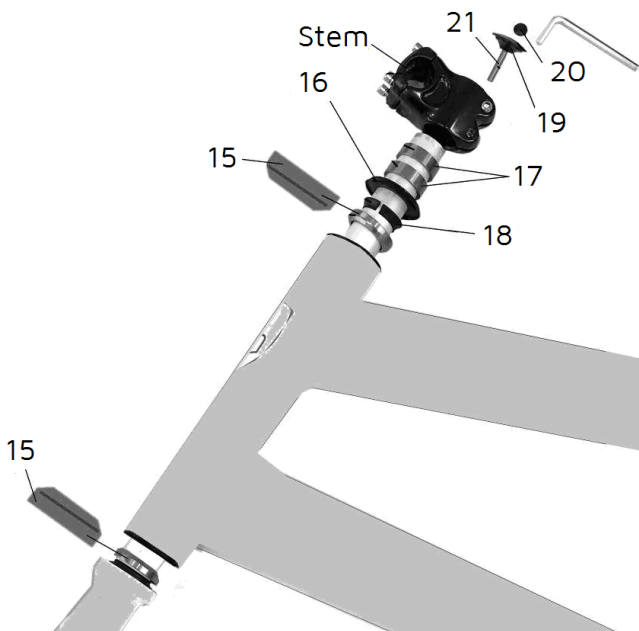

## **2) Mounting the shock absorbers**

Therefore you need the two shock absorbers. Please note that they have different coil springs! The spring rate is printed on the coil. For front 350 LBS and for rear 650 LBS. Also you need these parts:

- (A) 4 bolts 34mm with screw M6,
- (B) 1 bolt 24mm with screw M6,

- (C) 2 adapter plates alloy
- (D) 2 sleeves OD 12mm x 14mm

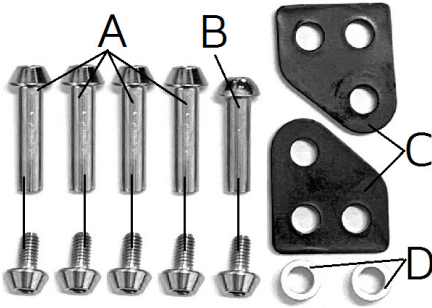

### **A) Mounting the rear shock for the lower Skibike position**

Lay the frame on its side and put the shock absorber mounts and the two adapter plates (C) in the brackets of the frame. Use the mounting points as shown in the pictures below. There red dial wheel must be pointed to the outside but it may be upwards or downwards. Slide in the supplied bolts (A) and lock them with the M6 screws by using the provided 5mm Allen Keys. If the bolts cannot slide through the bracket and the shock absorber mountings please twist the shock absorber to align the holes.



The position of the adapter plate in between shock and frame



The adapter plates are mounted as a spacer only

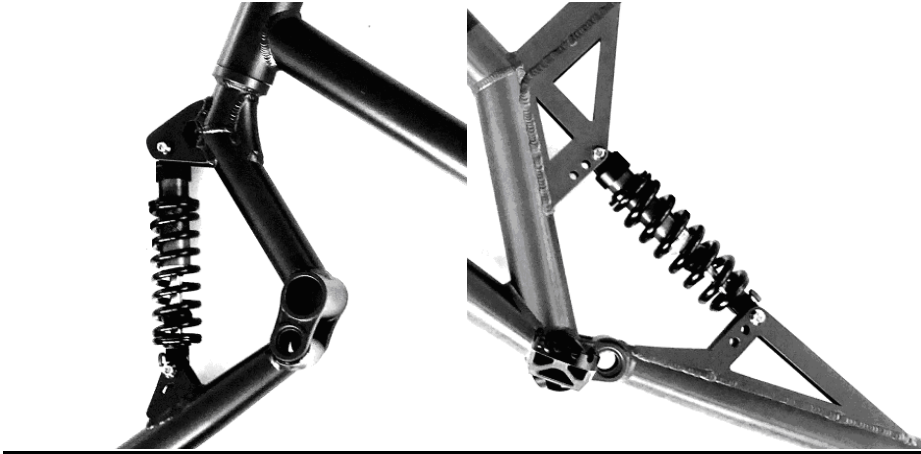

The low setup is recommended for beginners. It makes the foot pegs lower by 50mm, leading to a safer ride feeling. Additionally the Skibike becomes more agile and easier to ride stand up.

### **B) Mounting the rear shock for the higher Skibike position**

For the higher position you will need to assemble the shock adapter to prolong the rear shock. Therefore you will need to mount the adapter with two of the longer bolts (A) and the sleeves (D) to the frame and then the shock with the shorter bolt (B) to the adapter. Please take care to take the 14mm long sleeves. There are also two 16mm long sleeves which are not for this assembling step. The high position will make the Skibike more stable in turns and at high speed and gives more ground clearance. There are different positions you may realize with the adapter by mounting it either on the upper two or more down two holes of the three provided wholes ore even flip it the adapter plates. The lower the mounting point is the softer the setup becomes. The front will be mounted the same way as shown above under Point A - lower position.



Adapter mounted and an alternative position

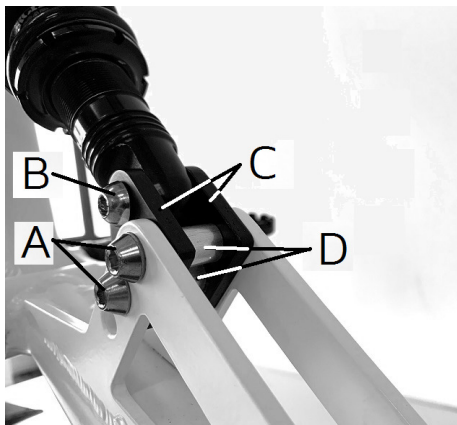

See the short bolt (B) and the sleeves (D)

But for the higher position you will also need to adjust the ski leveling. Due that the whole Skibike gets into a more upright position you will have to adjust the ski retention to ensure that the skis are flat on the ground again. This will be explained under 5.3 more down this manual.

### **3) Setting the shock absorbers**

Please check to ensure that the coil spring of the shock absorber is securely tightened. It should not be loose. The pre load can be adjusted by screwing the spring plate up and down on the shaft of the shock absorber. By compressing the spring you can adjust the Skibike for heavier riders. Please do not compress the spring more than 15% of its unloaded length. If it is still too soft please change the shock absorber position to the more outer holes.

You can mount the rear shock absorber at three different positions. The upper position makes the Skibike suitable for heavier riders and the lower position for lighter riders. We recommend to check all positions and find out what is best for you.

Shocks are temperature sensitive and should be checked and adjusted if necessary before each ride. The shock absorber has an adjustable rebound (red) dial wheel. This means that you can alternate the expansion speed of the shock absorber. Adjusting the rebound compression wheel (red) will allow the shock to recover after being compressed. AS a rule you can say that it should be around 0.5 seconds to recover after a heavy bump. So jump on the foot pegs and see if it needs around this time to come up again.

Please contact your retailer or local distributor for assistance or questions about adjusting the shocks.

#### **4) Mounting the handle bar**

Take out all bolts of the stem with the packed by Allen key. See fig 3.

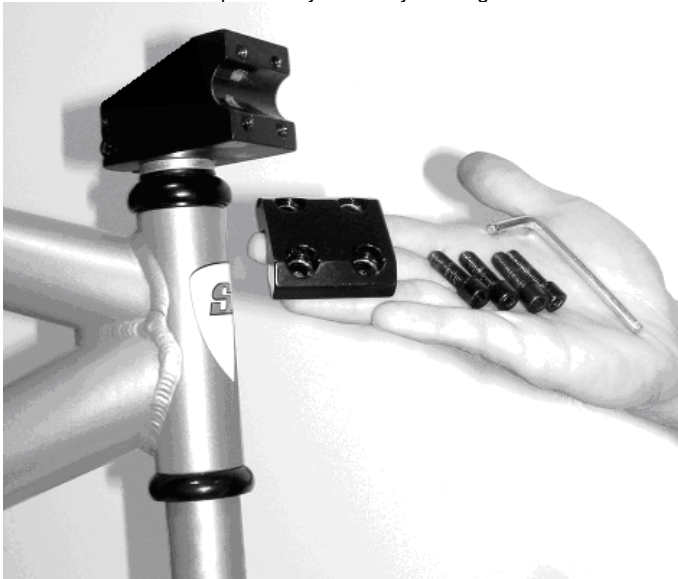

Now put the handle bar in place and close the stem. Tighten the four bolts using a cross pattern so that the gap in between the cap and the stem remains parallel and even. See figures below:

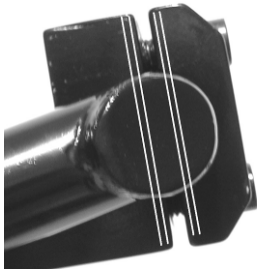

right

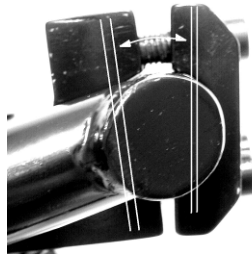

wrong

Then sit on the Skibike and twist the fork and handle bar until the fork is straight forward and tighten the two bolts on the side of the stem. Please tighten them alternating at least two times each until they are both tight.

## 5. Mounting the skis

### 5.1. Mounting the brackets on the skis

Put the rubber plate (12) on the skis and the brackets (11) one ski and the Edge Power Plate (14) on the other ski. Screw in two of the 6 flat head bolts (10) to each ski (the two rear bolts of the front ski and the two front bolts of the rear ski). See picture below. Use the Allen key provided. Do not tighten them fully now.

front ski -> ride direction

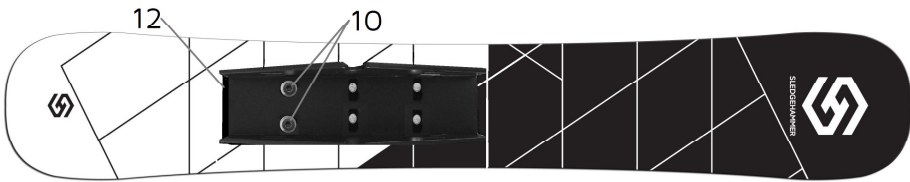

rear ski -> ride direction

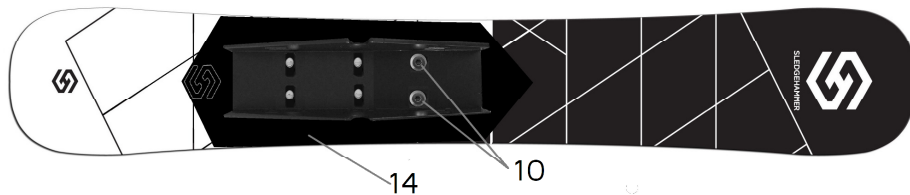

Now mount the skis on the Skibike as explained under 5.4. Then turn the Skibike around and place it on its skis.

Make sure that the skis are standing in one line - see pictures below. You can correct it if they do not align by pushing them in the right alignment position. Take a brief look from the rear and the front and check the line of the skis.



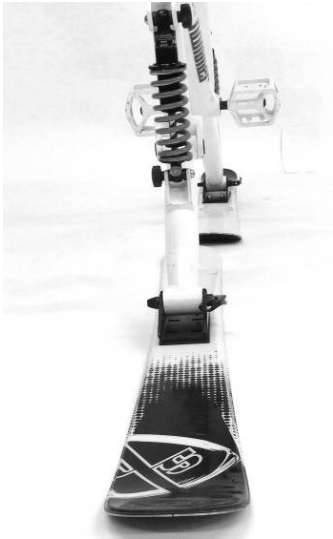

wrong

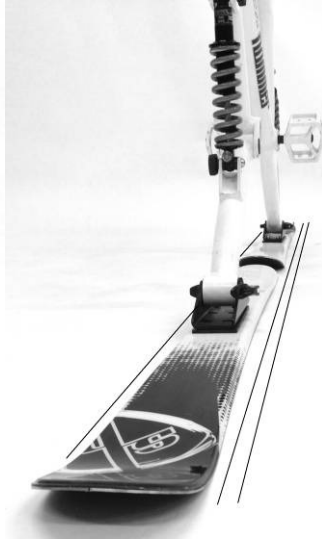

right

As soon as their position is perfect screw in the outer bolts and tighten them with a force of 3 Nm (27 LBF) - the Skibike still standing on the skis. This is equal the force of 3kg or 6 pounds provided on an Allen key of 10 cm (4 inch) length.

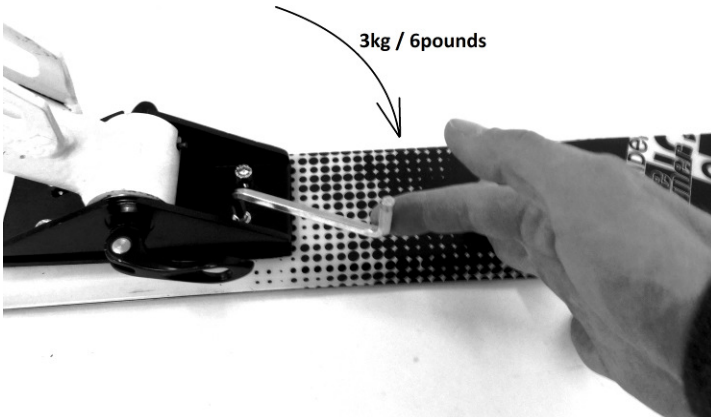

Now take of the skis off carefully and screw in the missing bolts and tighten all bolts with the same force.

## 5.2 Mounting the Ski brackets

The brackets are now mounted on the skis. We show the next step without the skis for better visibility. First please assemble the

First you will need to assemble the rubber cushion. For this step you need some parts of (9):

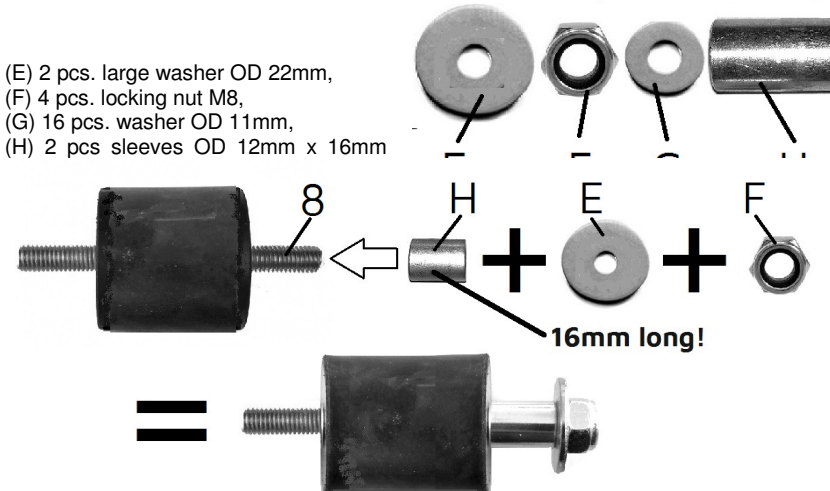

Please take the two T-plates (13) for each bracket and slide them into the brackets as shown. For the front Ski slide them in the rear square orifices and for the rear in the front ones (if you will assemble your Skibike for riding in the high position please jump to point 5.3 now). Please be careful to put them exactly into the bracket as shown on these pictures: Take one washer (E) and one nut (F).

riding direction front ski ->



riding direction rear ski ->

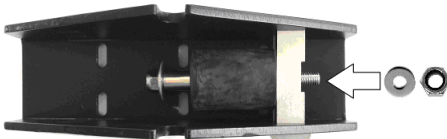

Then tighten the nut (F) and make sure that the washer and the nut are sitting into the slot. By tightening the nuts both Insert plates are pulled tight so that the assembly will sit very tight and without any play.

### 5.3. Mounting the rear bracket for the higher Skibike position

You will need to assemble your rear ski differently. The front ski will be assembled as shown under 5.2. For the rear ski you will need to slide in the T-Plates (13) to the rear square holes and in between the rubber cushion (8) and the T-plates you need to put two washers (G). This is necessary to keep the rear ski tip showing slightly upwards.

riding direction rear ski ->

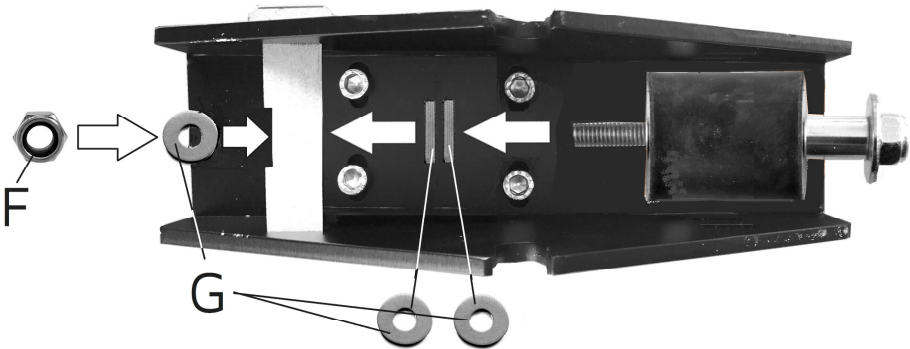

### 5.4. Mounting the skis on the Skibike

For transport purposes you can easily demount the skis within seconds.

For mounting the skis please flip the Skibike over and place it on its handle bars. Set the skis straight into the axles in approximately the same angle as shown in the picture below and press them to lock the brackets into the axles.

The narrow part/ the axle of the rubber cushion has to slide into the "fork" of the swing arm. Make sure that it slides on fully and is a snug fit.

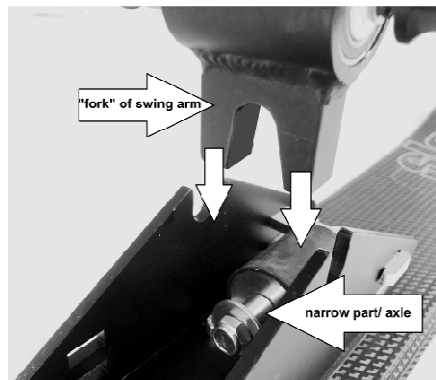
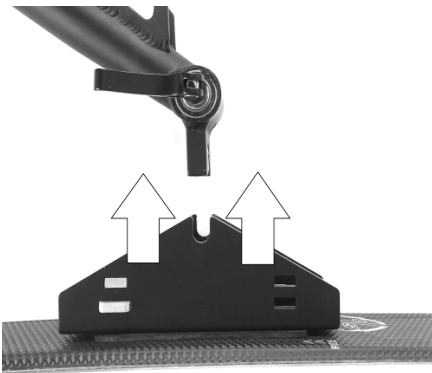

Now close the quick release system by pushing the lever towards the bracket facing the rear - see the left picture above. When pushing the lever, you should feel that the force is fairly tight and snug. If not, reopen the lever and tighten the nut on the opposite side (see right picture below) on the axle and try again. Repeat this until you are sure that the quick release is securely closed.



Please check that the skis return to the horizontal position after pushing them in any direction.

**!!!ATTENTION!!!**

***Please double check after every crash and before every chair lift ride that the skis are horizontal when you lift the Skibike.***

**!!!ATTENTION!!!**

***Never ride or transport your Skibike when the skis are not securely locked.***

## **6.) Mounting the foot pegs**

Please be aware that there is a right and left peg, though they look similar. The sides are seen in the direction of riding when seated on the Skibike. There is a stamp on the inside of the mounting brackets and on the top of each peg indicating right and left.

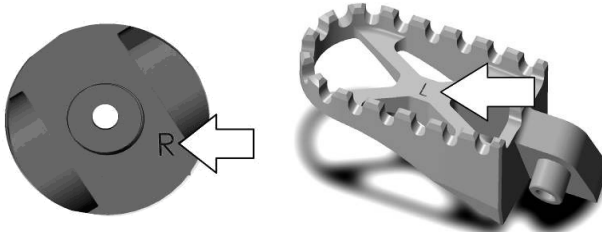

First disassemble both foot pegs fully as shown in the picture below. Then put the brackets into the frame. Then slide the long 8mm x 64mm Bolt (5) in one side and tighten it with the screw. As shown in the last picture down here.



Be aware that the foot pegs will have the same angle position the brackets have when you tighten the bolts. For a horizontal position you can lay some ruler on top of the brackets and align it with the down tube as shown in the picture below. Now tighten the bolts.

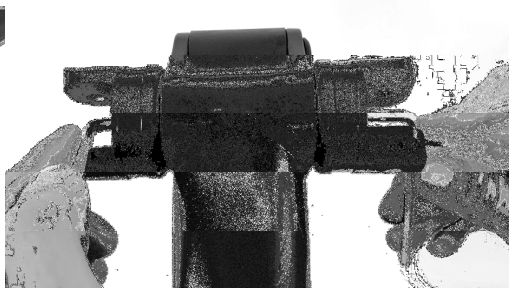
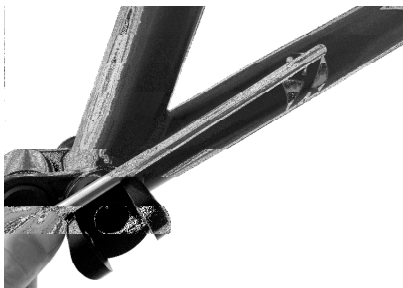

Assemble the pegs fully again. Please note that it may require some force to compress the spring so that you can slide the bolts back in again.

**GREAT! Your Skibike is now assembled !**

## **C) Before every ride**

For your own safety and the safety of others please check that the quick releases are properly closed. Also please check daily if the rubber stoppers on the skis and grips are o.k. They should neither be damaged or loose.  
Also please frequently check if both skis are horizontal when lifting the Skibike.

## **D) Checks after every 10 rides**

Please check if the screws/ bolts holding the brackets on the skis are tight. The rubber might soften after the first use which might lead to loose bolts.

Please check that the nuts of the shock absorbers are tightened and the springs are not loose. Lift the bike and check if the springs still have tension. They should not lay loose in the shocks.

And check if the rubbers/ grips are o.k. They should neither be damaged nor loose.

In general please check all nuts and bolts to be securely tightened from time to time.

## **E) Instructions for use**

The Sledgehammer is built for everyone from 14 to 99 years old taller than 4' 9" and a weight limit of 280 lb. We explicitly want to mention that this Skibike is NOT suitable for kids and children younger than 14 years of age!

Please note that if your weight is more than 240 lb, we recommend ordering a stronger spring for the shock absorber. This can be done via email on our homepage [www.sledgehammer.at](http://www.sledgehammer.at) or contact your local supplier.

Always use a helmet, gloves and good boots. We further recommend wearing protection for your back if you want to play hard!

Please be aware when handling the Skibike that you might hurt yourself and others. The Skibike has sharp edges on the skis.

Skibiking requires a good body fitness. You should be able to climb a steep mountain for 30 Minutes or ride a bicycle uphill for this time.

Also it requires balance and reaction. Please do not use a Skibike after consuming alcohol or other narcotics.

## **F) Where to use the Sledgehammer**

You can use it wherever is snow and it is steep enough but not too steep terrain. This is the big advantage of the Sledgehammer compared to a toboggan. You can use it on toboggan tracks, on slopes and off piste. You can carve down groomed runs or go for powder snow. Please respect your limits and start to Skibike slowly. Start on the green/ blue or easiest runs first until you feel

comfortable to move to steeper runs. PLEASE SEE OUR INSTRUCTION VIDEOS! Got to youtube.com and look for Sledgehammer Skibikes Instruction videos.

Our suggestions for using different style lift facilities are:

### **Anchor lift/ T-bar lift**

Push yourself, sitting on the Skibike, in the line of the anchor lift. Take the oncoming anchor and push it behind your back. If you have an anchor lift device please use it according to the instructions shown on our website. When riding with the lift you will have to hold your balance by putting your feet to the ground. On the end – on top of the lift – take the rod of the anchor, push it away. Leave the line of the lift quickly. You will find a video on our homepage showing the usage of lifts.

### **Chair lift**

Contact your local mountain for safety rules and regulations for transporting your skibike on chair lifts.

In Austria you are allowed to use chair lifts that may transport pedestrians. These chairlifts are marked - or those who will not are marked clearly. Again please see our instructions for riding chair lifts.

### **Gondolas/ Cabin Lifts and other housed lift facilities**

Please take off the skis and place the Skibike and the skis in the housing/ cabin. Do NOT put the Skibike in any way into the ski racks outside the cabin!

For more information please see our instruction video at: [www.sledgehammer.at](http://www.sledgehammer.at)

## **G) General use on the slope**

Please remember, just like any alpine sport, riding a Skibike is a high risk activity! Therefore always keep in mind that you are not alone riding down the slope. Your gear has sharp edges and can hurt others. So adapt your manners of riding, remember the rider responsibility code and pay very high attention to others around you.

## **H) How to ride the Sledgehammer Skibike?**

We strongly recommend to watch out instruction videos on [www.sledgehammer.at](http://www.sledgehammer.at) or [www.youtube.com](http://www.youtube.com) search for "Sledgehammer Skibikes".

You can ride while seated or standing on the foot pegs. If you are riding through rough terrain it's better to stand up and absorb with your knees like riding a bicycle on rough ground.

When riding slow, steer the Sledgehammer the same way you do when riding a bicycle. The faster you are going the more you should keep the handlebar straight and steer by shifting your weight to the side you want to go. The same way you do with carving skis. This will enable the skis to carve and you will have great fun!

The Sledgehammer 5.2 Skibike was designed to be a Stand Up Bike. Unlike our previous models this model has bigger and lower foot pegs. This enables you to safely stand up with the "Skid Turn Style". You can do short swings with the rear skis controlling your down hill speed.

### **How to brake?**

You can slide or drift or hockey stop ( like you do with skis and skates ) the Skibike until the skis are across the slope from the fall line. Put your full weight on the outer foot rest and put the inner foot to the snow. It is like a side skid on a bike. You can also use your boots and drag them into the snow until you learn how to hockey stop.

**!!!ATTENTION!!!**

**Please make sure that you are able to stop before riding in steep terrain or on public slopes.**

### **I) Guarantee / Warranty**

Sledgehammer will replace broken components (spare parts) under our 2 year manufacturer's warranty as long as there is correct use.

No warranty will be given on wear and tear elements like bearings, grips, seat covers, footpegs and the skis.

### **J) Spare parts**

You can order spare parts anytime via E-mail or by using the contact form on our homepage [www.sledgehammer.at](http://www.sledgehammer.at) or by phone: +43 (0)2256 / 20393 or contact

**Your local distributor:**

**And now enjoy your Sledgehammer Skibike!**

**We are very pleased if you send us any action photos!  
Please contact us via our homepage.**

Seldgehammer Wintersport GmbH  
Babenbergerstrasse 40  
2500 Baden  
Austria  
tel.: +43(0)2256 20393  
mail: office@sledgehammer.at

**Copyright © SHWS 2020**