

PRODUCT CATALOG

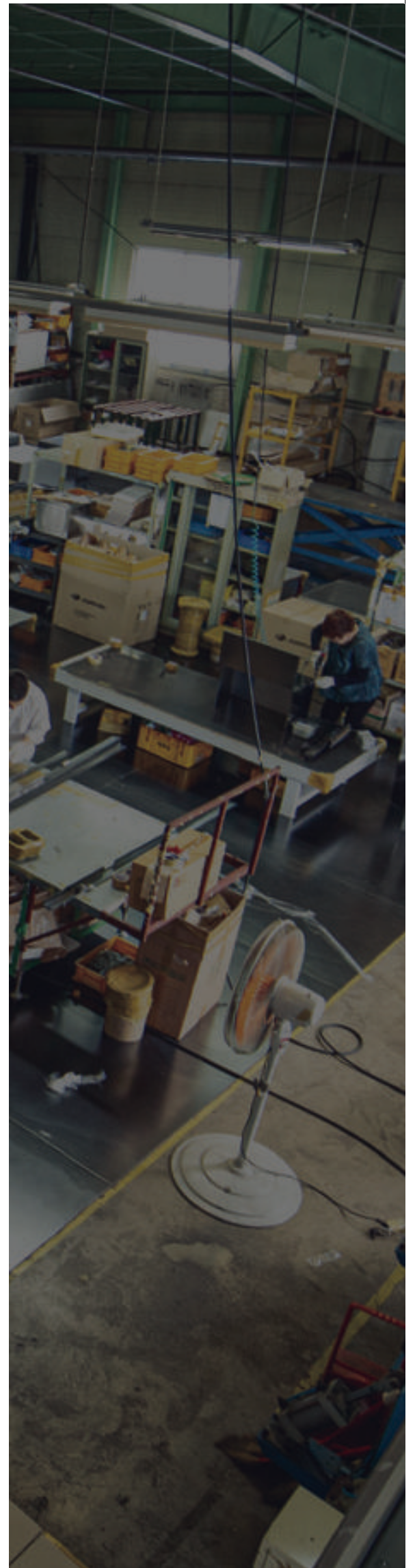

BEST QUALITY FROM THE BEST

Fresh has been dedicated to being a commercial refrigeration company that offers product quality which meets the customer's satisfaction at competitive price. To achieve the recognition, Fresh has constantly focused on innovation and investment in cutting-edge technology and facilities throughout the business years. Leveraging this industry-leading heritage, we promise to deliver outstanding products to our customers all over the world. I do consider our customer's business successes and want to be their supportive partner. Our goal is to provide the best solution through endless improvements and best service beyond the needs of industry.



- **2001** **JUN** | Established Fresh Town
- **2002** **APR** | Achieved UL Certification
MAY | Supplied to Blue Air in US
- **2004** **FEB** | Achieved UL NSF Certification
- **2005** **JAN** | OEM Contract with Daeyoung (Lassele)
- **2008** **DEC** | Converted into Corporation
- **2009** **SEP** | Supplied to Standex in US (via Lotte)
- **2010** **AUG** | Achieved ETL Certification
- **2012** **AUG** | Relocated Factory for Expansion
DEC | Selected as Outstanding Medium-sized Enterprise of Incheon
- **2014** **DEC** | Released Bar Products
- **2016** **DEC** | Won 10 Million Dollar of Exports Award
Selected as Main-Biz (Innovative SME)
- **2017** **JUN** | Achieved ISO 9001:2015
Supplied to Titan in US
OCT | Certified as Company of Well-compensate for Employee's Invention
- **2018** | Register full range to DOE (US)
- **2019** **JAN** | Applied R290 Compressor to all products exported to US
- **2020** | Register full range to MEPS (AU)
- **2020** | Developed Blast Chiller

TABLE OF CONTENTS

1

UPRIGHT

Top Mount Upright.....	08
Glass Door Top Mount Upright	10
Top Mount Upright.....	12
High Top Mount Upright.....	14
Bottom Mount Upright	16
Glass Door Bottom Mount Upright	18
High Bottom Mount Upright	20

2

PREP TABLE

Salad & Sandwich Prep Table	24
Megatop Food Prep Table	26
Slide Top Prep Table.....	28
Glass Canopy Salad Prep Table	30
Open Air Salad Table	32
Pizza Prep Table	34
Narrow Pizza Prep Table	36

3

UNDERBENCH & CHEF BASE

Underbench.....	40
Underbench Drawer.....	42
Glass Door Underbench.....	44
Dual Temperature Underbench	46
3-Drawer Underbench	48
Rear Mount Underbench	50
Multi Temperature Underbench.....	52
Chef Base.....	54

4

BAR EQUIPMENT

Beer Dispenser	58
Bottle Cooler	60
Back bar.....	62
Countertop Fridge.....	64

5

DISPLAY CASE

Open Display Multideck.....	68
Rectangular Bakery Case.....	70

6

BLAST CHILLER

Blast Freezer.....	74
--------------------	----





A large, dark blue geometric shape that starts as a triangle at the top left and extends as a vertical bar on the right side of the page.

1

UPRIGHT

Top Mount Upright

Glass Door Top Mount Upright

High Top Mount Upright

Bottom Mount Upright

Glass Door Bottom Mount Upright

High Bottom Mount Upright

TOP MOUNT UPRIGHT



KTM-25RS1
KTM-25FS1



KTM-25RS2
KTM-25FS2



KTM-45RS2
KTM-45FS2



KTM-45RS4
KTM-45FS4

UPRIGHT

FEATURES

- Auto-closing doors & stopper
- Door pressure release device
- Magnetic door gasket
- Door sensor with magnetic switch
- Door locks
- Extra-large internal capacity
- Digital temperature control & monitor system
- 3" casters (brakes at front)
- LED lighting interior
- Stainless steel finished top, front, sides and doors
- PE coated sturdy wire shelves

TEMPERATURE

- Fridge: 0°C ~ 5°C
- Freezer: -18°C

OPTIONAL MODELS

- GN pan compatible model
- 4" or 5" casters
- Left hinged reversible (25 model only)

PLAN VIEWS & SPECIFICATIONS

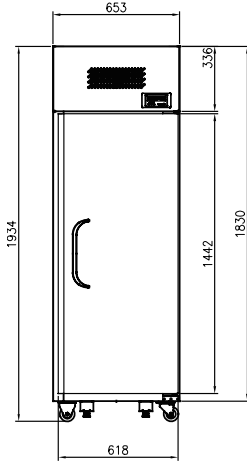
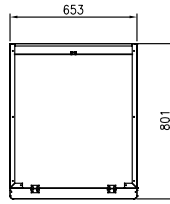
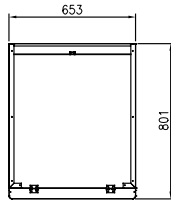

KTM-25RS1 / KTM-25FS1

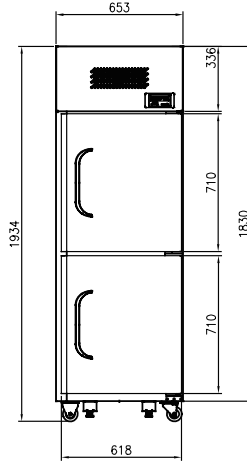

KTM-25RS2 / KTM-25FS2

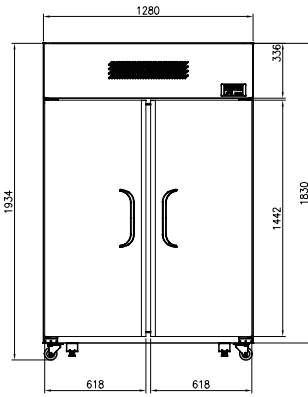
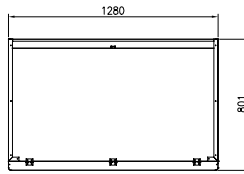
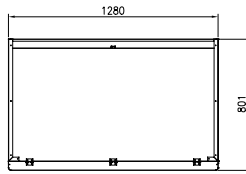

KTM-45RS2 / KTM-45FS2

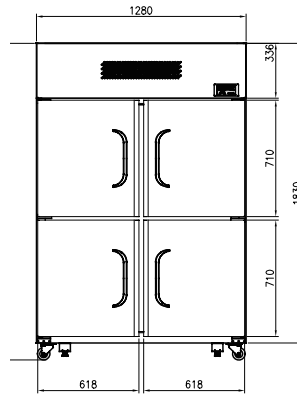

KTM-45RS4 / KTM-45FS4

SIDE PLAN

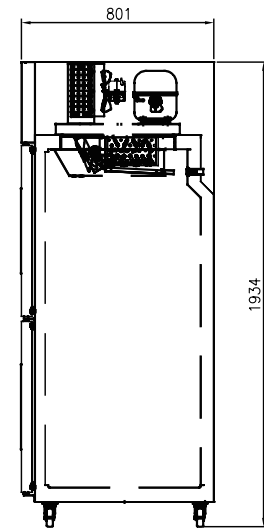

UPRIGHT

* D : Deforst

Model	Capacity (ℓ)		Exterior Dimension (mm)			Net Weight (kg)	Power Supply	Amps	Watt	HP	Refrigerant	No. Door	Type
	Gross	Net	W	D	H								
KTM-25RS1	480	445	653	801	1,934	102	10A	3.2	380	3/8	R-134a	1	Fridge
KTM-25RS2	480	445	653	801	1,934	103	10A	3.2	380	3/8	R-134a	2	Fridge
KTM-45RS2	1,034	960	1,280	801	1,934	153	10A	4.0	400	3/8	R-134a	2	Fridge
KTM-45RS4	1,034	960	1,280	801	1,934	155	10A	4.0	400	3/8	R-134a	4	Fridge
KTM-25FS1	480	445	653	801	1,934	104	10A	4.0	400(D:550)	3/8	R-134a	1	Freezer
KTM-25FS2	480	445	653	801	1,934	105	10A	4.0	400(D:550)	3/8	R-134a	2	Freezer
KTM-45FS2	1,034	960	1,280	801	1,934	163	10A	6.0	1350(D:820)	3/4	R-404A	2	Freezer
KTM-45FS4	1,034	960	1,280	801	1,934	165	10A	6.0	1350(D:820)	3/4	R-404A	4	Freezer

GLASS DOOR TOP MOUNT UPRIGHT

UPRIGHT



KTM-25RG1
KTM-25FG1



KTM-45RG2
KTM-45FG2

FEATURES

- Auto-closing doors & stopper
- Door pressure release device
- Magnetic door gasket
- Door sensor with magnetic switch
- Door locks
- Triple pane glass (Freezer)
- Digital temperature control & monitor system
- 3" casters (brakes at front)
- LED lighting interior
- Stainless steel finished top, front, sides and doors
- PE coated sturdy wire shelves

TEMPERATURE

- Fridge: 0°C ~ 5°C
- Freezer: -18°C

OPTIONAL MODELS

- GN pan compatible model
- Left hinged reversible (25 model only)
- 4" or 5" casters

PLAN VIEWS & SPECIFICATIONS

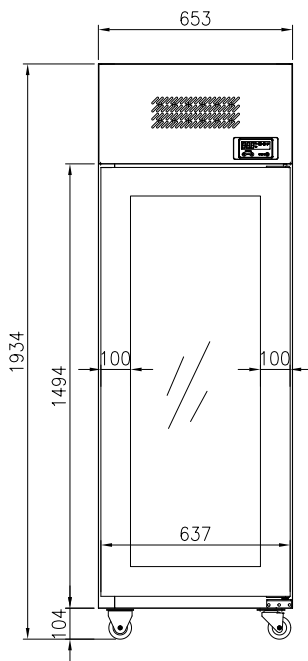
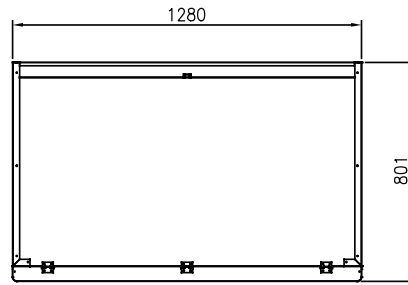
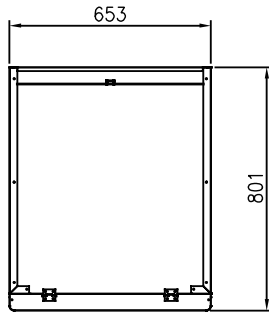

KTM-25RG1 / KTM-25FG1

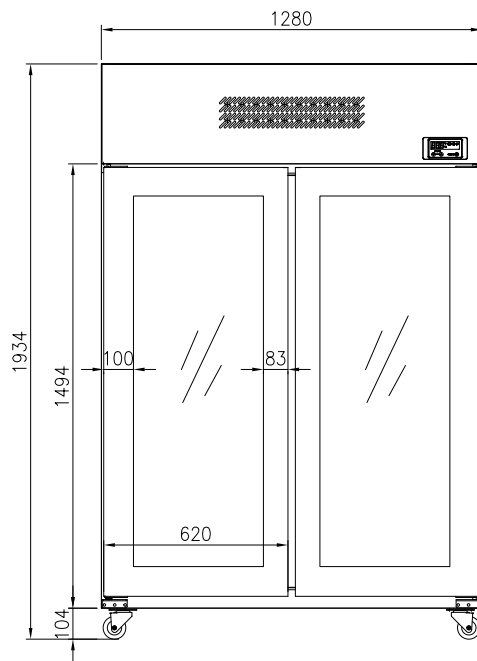

KTM-45RG2 / KTM-45FG2

SIDE PLAN

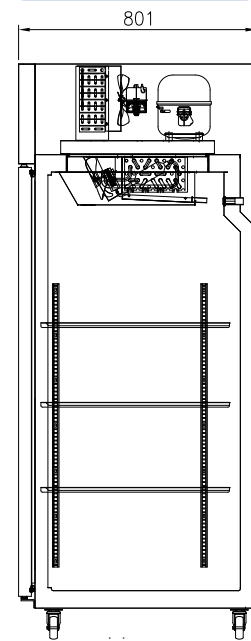

UPRIGHT

* D : Deforst

Model	Capacity (ℓ)		Exterior Dimension (mm)			Net Weight (kg)	Power Supply	Amps	Watt	HP	Refrigerant	No. Door	Type
	Gross	Net	W	D	H								
KTM-25RG1	480	445	653	801	1,934	102	10A	3.2	380	3/8	R-134a	1	Fridge
KTM-45RG2	1,034	960	1,280	801	1,934	153	10A	4.0	420	3/8	R-134a	2	Fridge
KTM-25FG1	480	445	653	801	1,934	104	10A	6.0	1330(D:550)	3/4	R-404A	1	Freezer
KTM-45FG2	1,034	960	1,280	801	1,934	163	10A	7.5	1650(D:820)	1 1/4	R-404A	2	Freezer

TOP MOUNT UPRIGHT

UPRIGHT



KTM-25RF



KTM-45RF

FEATURES

- Auto-closing doors & stopper
- Door pressure release device
- Sturdy and easy grip handles and doors that open effortlessly
- Magnetic door gasket provides easy to remove for cleaning or replacement
- Bright and clear interior LED for excellent visibility
- Door sensor with magnetic switch and door locks (Standard for one-piece door)
- Flush mounted digital controller with fast cooling feature
- Insulation PE Coated Sturdy Wire Shelves

TEMPERATURE

- Fridge: 0°C ~ 5°C
- Freezer: -18°C

PLAN VIEWS & SPECIFICATIONS

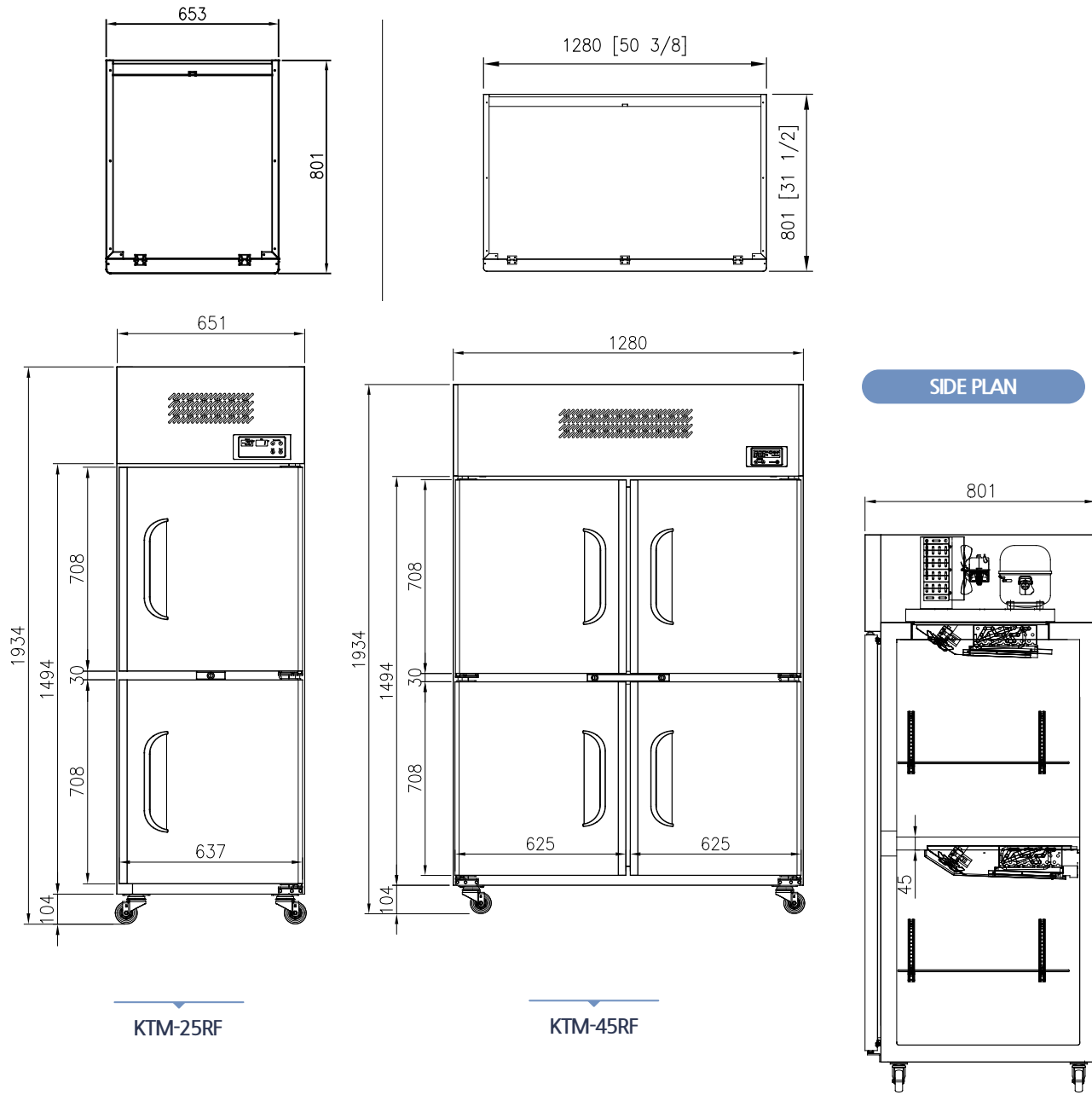

UPRIGHT

* External dimensions include 3" caster height

Model	Capacity		Exterior Dimension			Net Weight (kg)	Amps	Voltage (V/Hz)	HP	Refrigerant	No. Shelves	No. Doors
	Gross	Net	W	D	H							
KTM-25RF	480	445	653	801	1,934	103	3.2	220~230/50,60/1	3/8	R-134a	2	2
KTM-45RF	1,034	960	1,280	801	1,934	153	4.0	220~230/50,60/1	3/8	R-134a	6	4

HIGH TOP MOUNT UPRIGHT



FTM-23RS
FTM-23FS



FTM-49RS
FTM-49FS



FTM-72RS
FTM-72FS

UPRIGHT

FETURES

- Auto-closing doors & stopper
- Door pressure release device
- Magnetic door gasket
- Door sensor with magnetic switch
- Door locks
- Extra-large internal capacity

- Digital temperature control & monitor system
- 4" casters (brakes at front)
- LED lighting interior
- Stainless steel finished top, front, sides and doors
- PE coated sturdy wire shelves

TEMPERATURE

- Fridge: 0°C ~ 5°C
- Freezer: -18°C

OPTIONAL MODELS

- Left hinged reversible door (23 model only)

PLAN VIEWS & SPECIFICATIONS

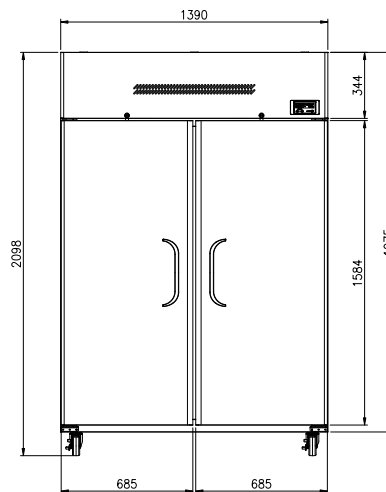
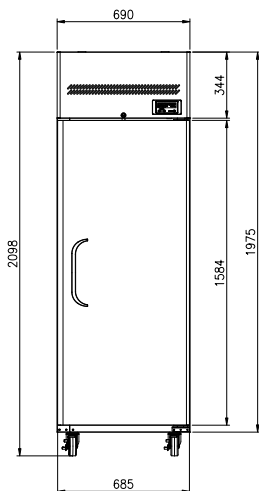
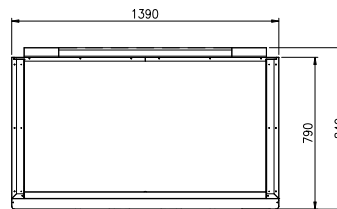
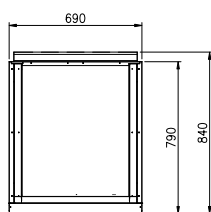

FTM-23RS / FTM-23FS

FTM-49RS / FTM-49FS

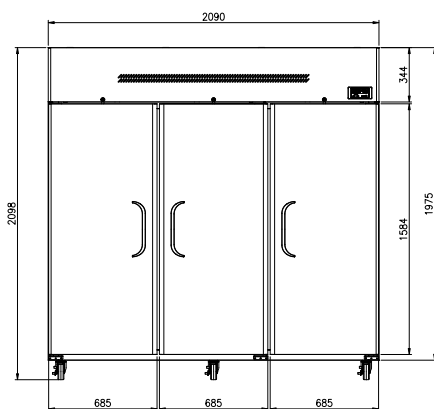
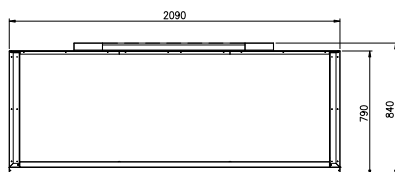

FTM-72RS / FTM-72FS

SIDE PLAN

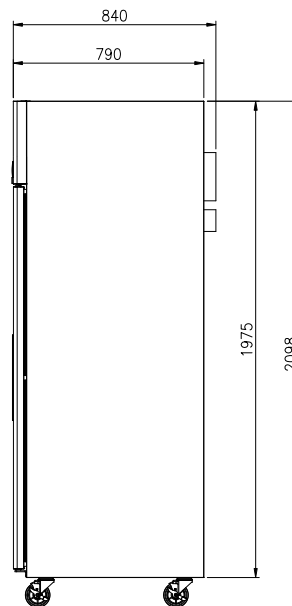

UPRIGHT

Model	Capacity (ℓ)		Exterior Dimension (mm)			Net Weight (kg)	Gross Weight (kg)	Power Supply	Amps	Watt	HP	Refrigerant	No. Shelves	No. Door	Type
	Gross	Net	W	D	H										
FTM-23RS	560	520	690	790	2,098	104	112	10A	3.2	400	3/8	R-134a	3	1	Fridge
FTM-49RS	1,236	1,160	1,390	790	2,098	150	167	10A	3.2	500	3/8	R-134a	6	2	Fridge
FTM-72RS	1,912	1,850	2,090	790	2,098	204	234	10A	6.0	900	1/2	R-404A	9	3	Fridge
FTM-23FS	560	520	690	790	2,098	112	120	10A	5.2	750	1/2	R-404A	3	1	Freezer
FTM-49FS	1,236	1,160	1,390	790	2,098	161	178	10A	5.5	1,090	3/4	R-404A	6	2	Freezer
FTM-72FS	1,912	1,850	2,090	790	2,098	220	250	10A	7.5	1,450	1 1/4	R-404A	9	3	Freezer

BOTTOM MOUNT UPRIGHT



KBM-25RS1
KBM-25FS1



KBM-25RS2
KBM-25FS2

UPRIGHT



KBM-45RS2
KBM-45FS2



KBM-45RS4
KBM-45FS4

FETURES

- Auto-closing doors & stopper
- Door pressure release device
- Magnetic door gasket
- Door sensor with magnetic switch
- Extra-large internal capacity

- Digital temperature control & monitor system
- 3" casters (brakes at front)
- LED lighting interior
- Stainless steel finished top, front, sides and doors
- PE coated sturdy wire shelves

TEMPERATURE

- Fridge: 0°C ~ 5°C
- Freezer: -18°C

OPTIONAL MODELS

- Left hinged reversible door (25 model only)
- 4" or 5" casters

PLAN VIEWS & SPECIFICATIONS

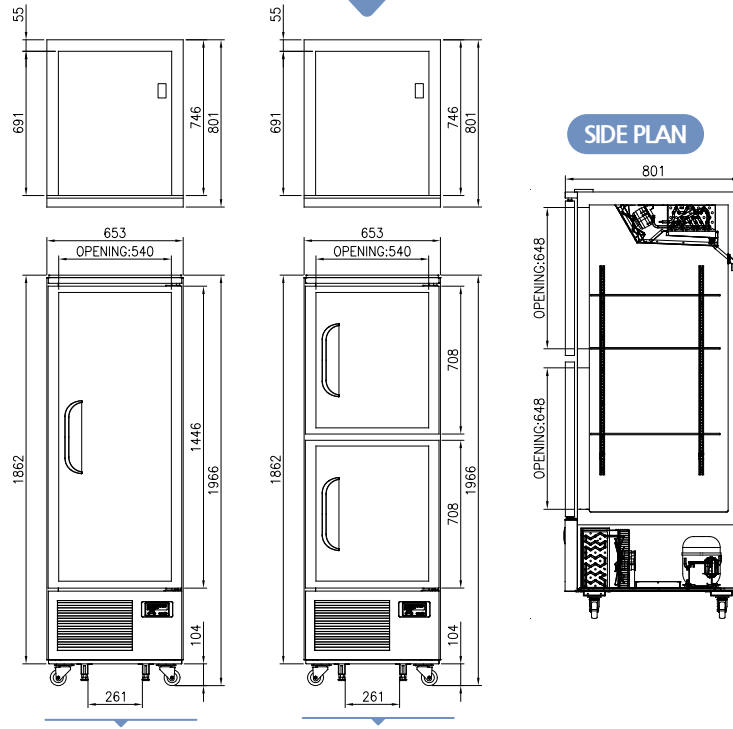

KBM-251

KBM-252

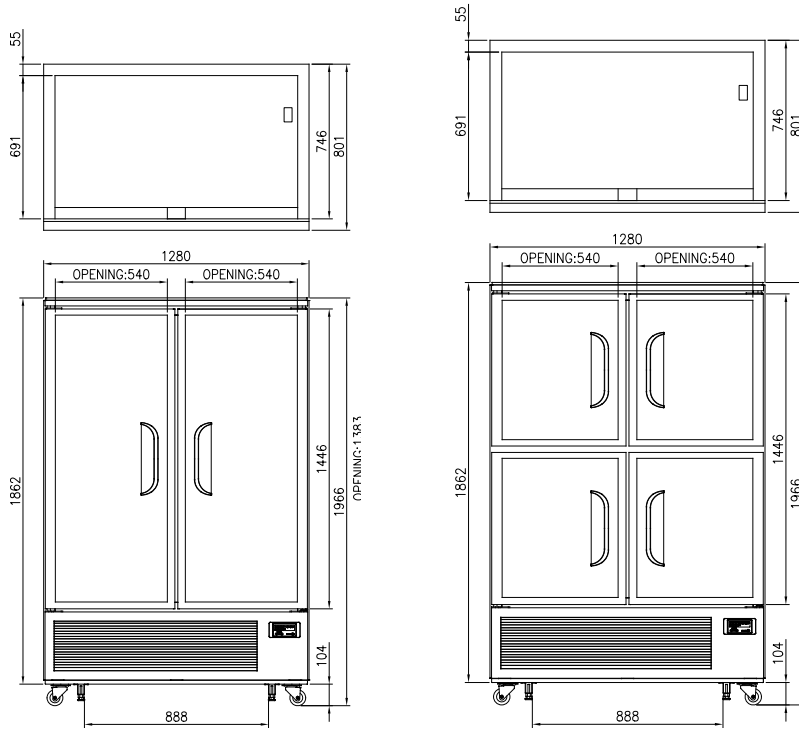

KBM-452

KBM-454

UPRIGHT

* D : Deforst

Model	Capacity (l)		Exterior Dimension (mm)			Net Weight (kg)	Power Supply	Amps	Watt	HP	Refrigerant	No. Door	Type
	Gross	Net	W	D	H								
KBM-25RS1	480	445	653	801	1,934	102	10A	3.2	380	3/8	R-134a	1	Fridge
KBM-25RS2	480	445	653	801	1,934	103	10A	3.2	380	3/8	R-134a	2	Fridge
KBM-45RS2	1,034	960	1,280	801	1,934	153	10A	4.0	400	3/8	R-134a	2	Fridge
KBM-45RS4	1,034	960	1,280	801	1,934	155	10A	4.0	400	3/8	R-134a	4	Fridge
KBM-25FS1	480	445	653	801	1,934	104	10A	4.0	400(D:550)	3/8	R-134a	1	Freezer
KBM-25FS2	480	445	653	801	1,934	105	10A	4.0	400(D:550)	3/8	R-134a	2	Freezer
KBM-45FS2	1,034	960	1,280	801	1,934	163	10A	6.0	1350(D:820)	3/4	R-404A	2	Freezer
KBM-45FS4	1,034	960	1,280	801	1,934	165	10A	6.0	1350(D:820)	3/4	R-404A	4	Freezer

HIGH BOTTOM MOUNT UPRIGHT



FRB-23RS
FRB-23FS



FRB-49RS
FRB-49FS



FRB-72RS
FRB-72FS

UPRIGHT

FETURES

- Auto-closing doors & stopper
- Door pressure release device
- Magnetic door gasket
- Door sensor with magnetic switch
- Door locks
- Extra-large internal capacity

- Digital temperature control & monitor system
- 4" casters (brakes at front)
- LED lighting interior
- Stainless steel finished top, front, sides and doors
- PE coated sturdy wire shelves

TEMPERATURE

- Fridge: 0°C ~ 5°C
- Freezer: -18°C

OPTIONAL MODELS

- Left hinged reversible door (23 model only)
- 3" or 5" casters

PLAN VIEWS & SPECIFICATIONS

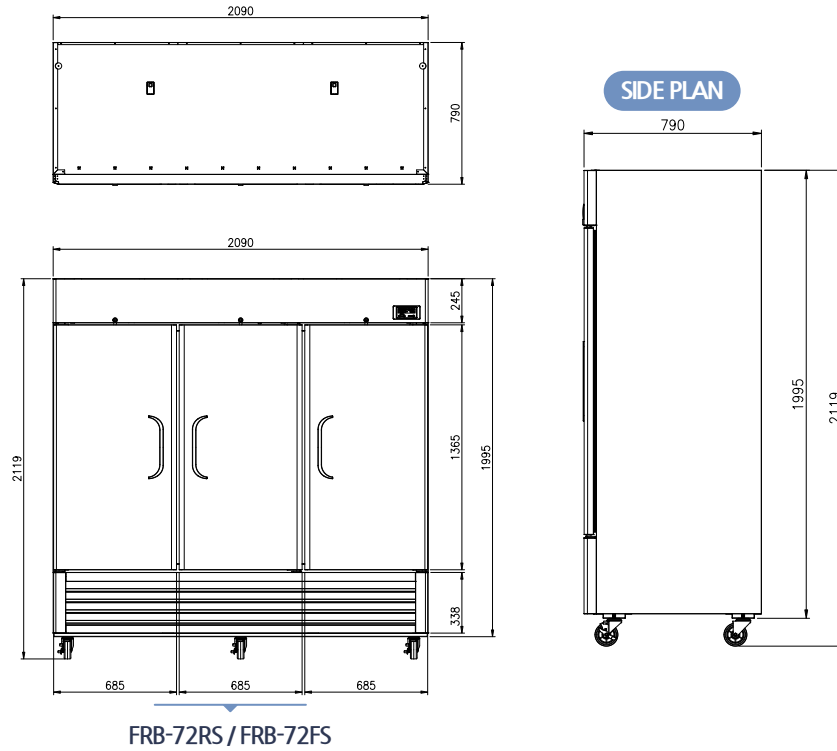
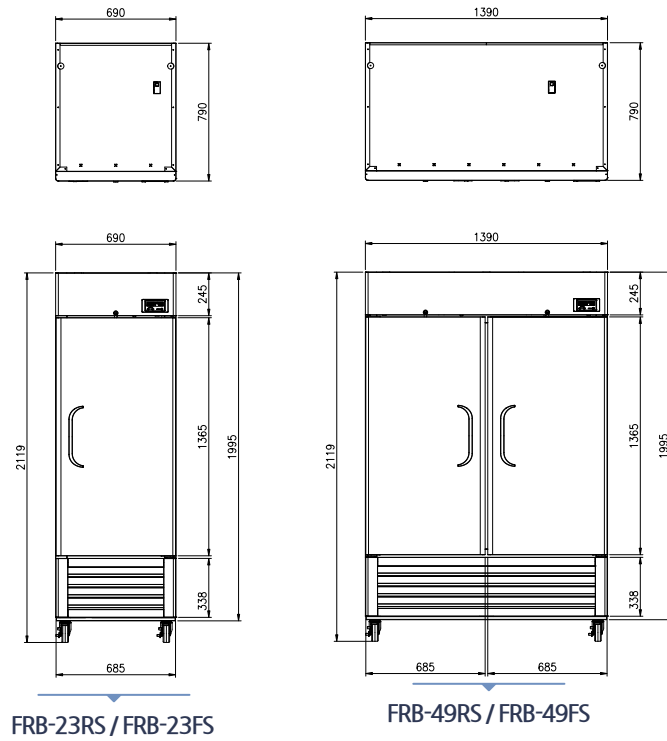

UPRIGHT

Model	Capacity (ℓ)		Exterior Dimension (mm)			Net Weight (kg)	Gross Weight (kg)	Power Supply	Amps	Watt	HP	Refrigerant	No. Door	Type
	Gross	Net	W	D	H									
FRB-23RS	560	516	690	790	2,119	108	116	10A	3.2	400	3/8	R-134a	1	Fridge
FRB-49RS	1,236	1,159	1,390	790	2,119	165	182	10A	3.2	500	3/8	R-134a	2	Fridge
FRB-72RS	1,912	1,805	2,090	790	2,119	220	250	10A	6.0	900	1/2	R-404A	3	Fridge
FRB-23FS	560	516	690	790	2,119	120	128	10A	5.2	750	1/2	R-404A	1	Freezer
FRB-49FS	1,236	1,159	1,390	790	2,119	177	194	10A	5.5	1,090	3/4	R-404A	2	Freezer
FRB-72FS	1,912	1,805	2,090	790	2,119	232	262	10A	7.5	1,450	1 1/4	R-404A	3	Freezer

GLASS DOOR BOTTOM MOUNT UPRIGHT

UPRIGHT



KBM-25RG1
KBM-25FG1



KBM-45RG2
KBM-45FG2

FEATURES

- Auto-closing doors & stopper
- Door pressure release device
- Magnetic door gasket
- Door sensor with magnetic switch
- Door locks
- Extra-large internal capacity
- Digital temperature control & monitor system
- 3" casters (brakes at front)
- LED lighting interior
- Stainless steel finished top, front, sides and doors
- PE coated sturdy wire shelves

TEMPERATURE

- Fridge: 0°C ~ 5°C
- Freezer: -18°C

OPTIONAL MODELS

- Left hinged model (door reverse)
- 4" or 5" casters

PLAN VIEWS & SPECIFICATIONS

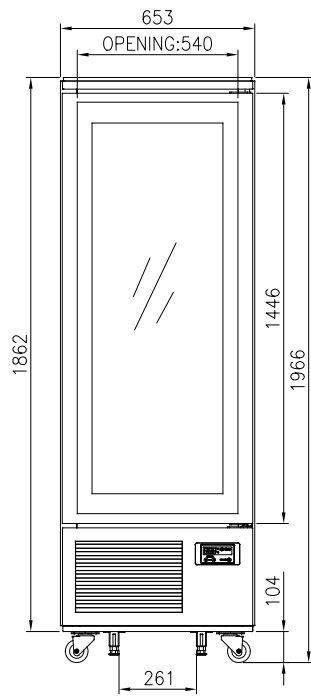
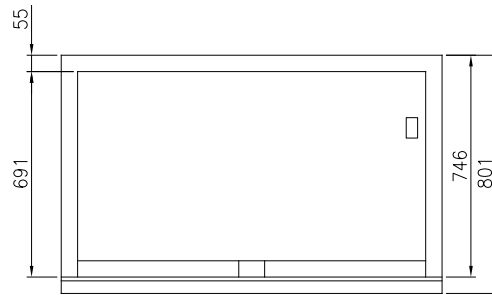
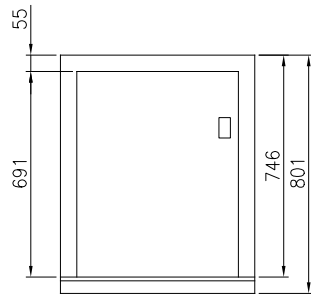

KBM-25RG1 / KBM-25FG1

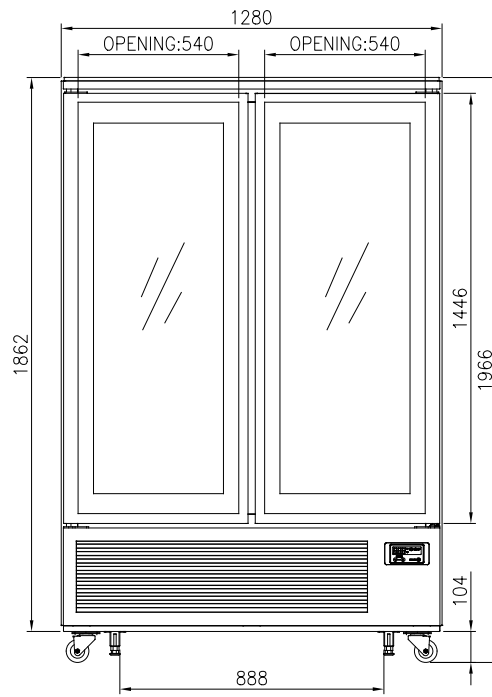

KBM-45RG2 / KBM-45FG2

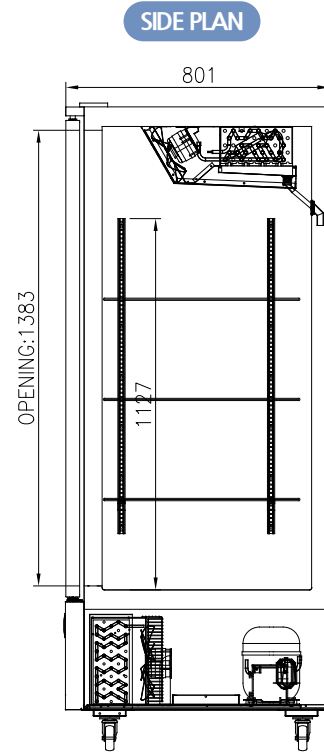

SIDE PLAN

UPRIGHT

* D : Deforst

Model	Capacity (ℓ)		Exterior Dimension (mm)			Net Weight (kg)	Power Supply	Amps	Watt	HP	Refrigerant	No. Door	Type
	Gross	Net	W	D	H								
KBM-25RG1	480	445	653	801	1,934	102	10A	3.2	380	3/8	R-134a	1	Fridge
KBM-45RG2	1,034	960	1,280	801	1,934	153	10A	4.0	420	3/8	R-134a	2	Fridge
KBM-25FG1	480	445	653	801	1,934	104	10A	6.0	1330(D:550)	3/4	R-404A	1	Freezer
KBM-45FG2	1,034	960	1,280	801	1,934	163	10A	7.5	1650(D:820)	1 1/4	R-404A	2	Freezer





2

PREP TABLE

Salad & Sandwich Prep Table

Megatop Food Prep Table

Slide Top Prep Table

Glass Canopy Salad Prep Table

Open Air Salad Table

Pizza Prep Table

SALAD & SANDWICH PREP TABLE



FSU-28



FSU-36



FSU-48



FSU-60



FSU-72

PREP TABLE

DRAWER MODELS



FSU-28-D2



FSU-36-D2



FSU-48-D4



FSU-60-D2



FSU-72-D4

FEATURES

- Auto-closing doors & stopper
- Stainless steel finished front, sides and doors
- Stainless steel hood lid covers
- Locking dividers
- 244mm reversible cutting board
- PE coated sturdy wire shelves

- Rear-mount compressor for enhanced airflow
- Airflow over the pans
- 5" casters (brakes at front)
- Accommodates 15cm deep pan
- * Food pans are NOT included

TEMPERATURE

- 0°C ~ 5°C

OPTIONAL MODELS

- Drawer model (custom-made)
- Drawer mixed model (custom-made)
- 3" or 4" casters

PLAN VIEWS & SPECIFICATIONS

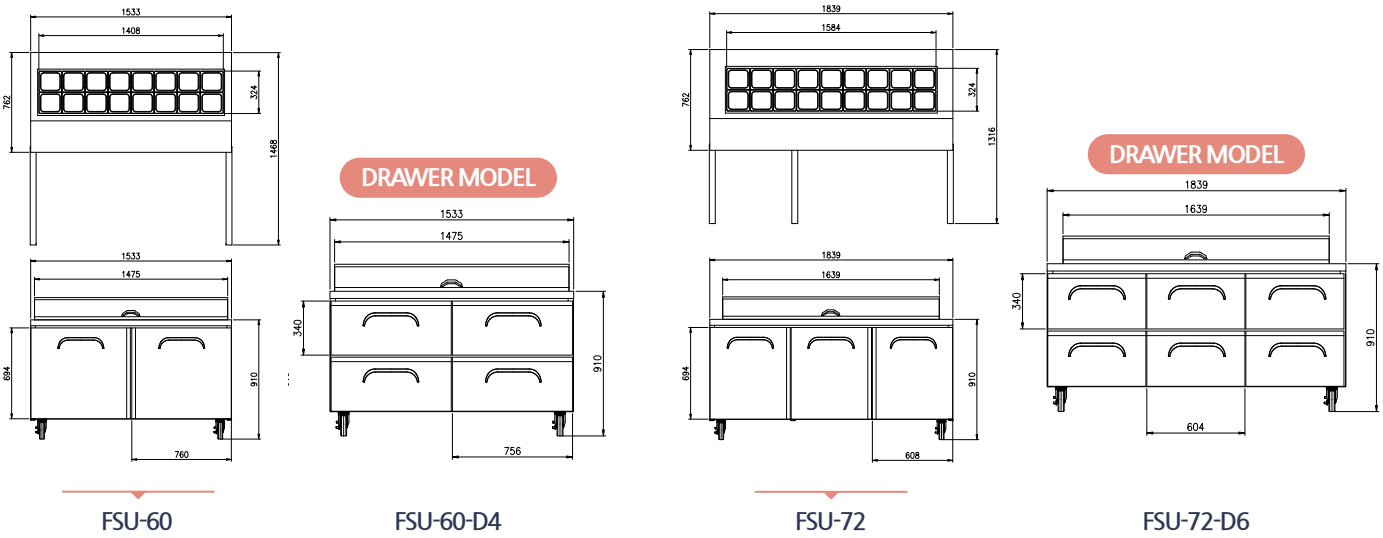
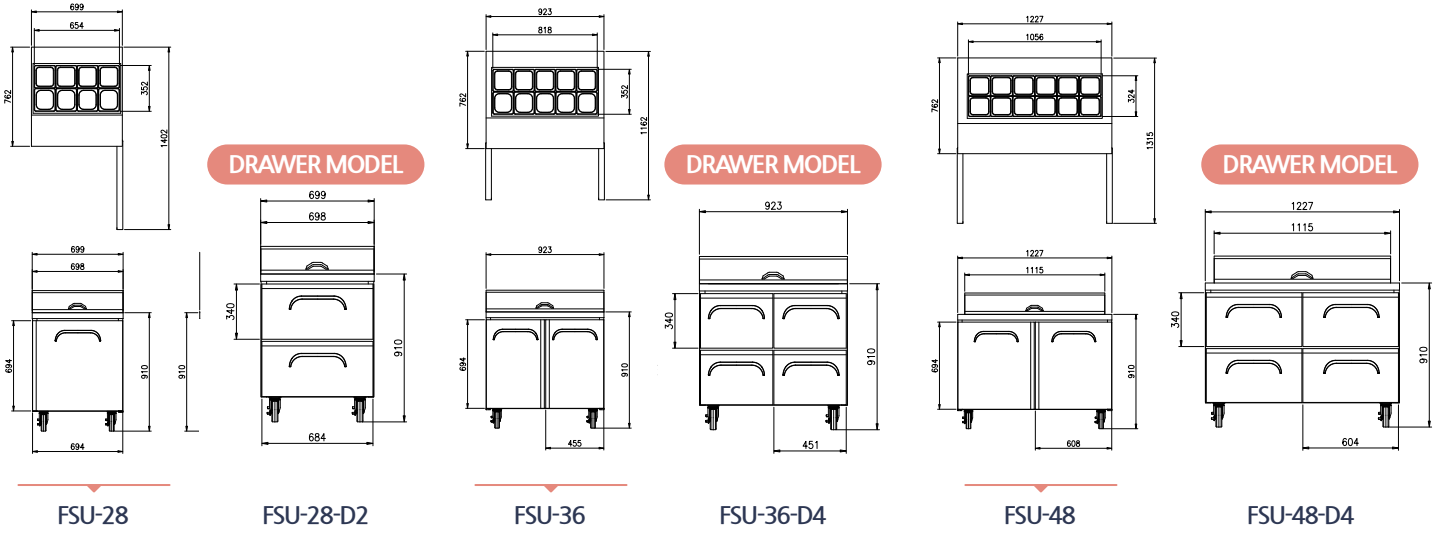

RPEP TABLE

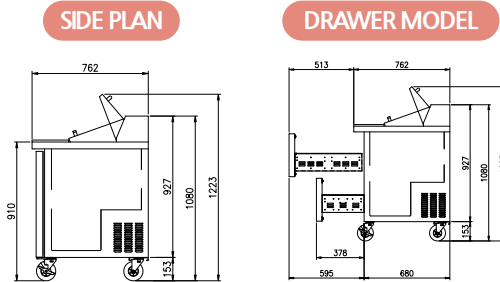

Model	Capacity (l)	Exterior Dimension (mm)			Net Weight (kg)	Gross Weight (kg)	Power Supply	Amps	Watt	HP	Refrigerant	No. Doors	No. Pans (1/6")
		W	D	H									
FSU-28	186	699	762	1,080	71	75	10A	2.0	320	1/5	R-134a	1	8
FSU-36	252	923	762	1,080	86	92	10A	2.0	320	1/5	R-134a	2	10
FSU-48	346	1,227	762	1,080	106	114	10A	3.2	340	3/8	R-134a	2	12
FSU-60	441	1,533	762	1,080	116	126	10A	3.2	340	3/8	R-134a	2	16
FSU-72	531	1,839	762	1,080	135	148	10A	3.2	340	3/8	R-134a	3	18
FSU-28-D2	186	699	762	1,080	85	89	10A	2.0	320	1/5	R-134a		8
FSU-36-D4	252	923	762	1,080	108	114	10A	2.0	320	1/5	R-134a		10
FSU-48-D4	346	1,227	762	1,080	132	140	10A	3.2	340	3/8	R-134a		12
FSU-60-D4	441	1,533	762	1,080	146	156	10A	3.2	340	3/8	R-134a		16
FSU-72-D6	531	1,839	762	1,080	175	188	10A	3.2	340	3/8	R-134a		18

MEGATOP PREP TABLE



FMU-28

FMU-36

FMU-48



FMU-60

FMU-72

PREP TABLE



DRAWER MODELS



FMU-28-D2



FMU-36-D4



FMU-48-D2



FMU-60-D2



FMU-72-D4

FETURES

- Auto-closing doors & stopper
- Stainless steel finished front, sides and doors
- Stainless steel hood lid covers
- Locking dividers
- 244mm reversible cutting board
- PE coated sturdy wire shelves

- Rear-mount compessor for enhanced airflow
- Airflow over the pans
- 5" casters (brakes at front)
- Accommodates 15cm deep pan
- * Food pans are NOT included

TEMPERATURE

- 0°C ~ 5°C

OPTIONAL MODELS

- Drawer model (custom-made)
- Drawer mixed model (custom-made)
- 3" or 4" casters

PLAN VIEWS & SPECIFICATIONS

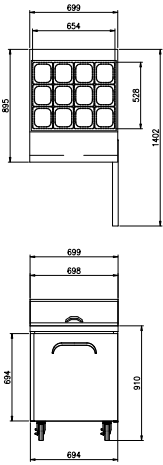

FMU-28

DRAWER MODEL

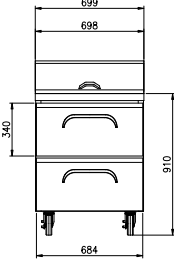

FMU-28-D2

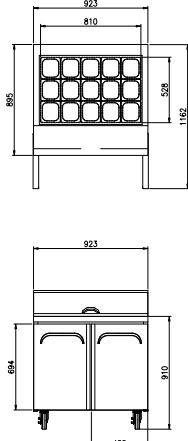

FMU-36

DRAWER MODEL

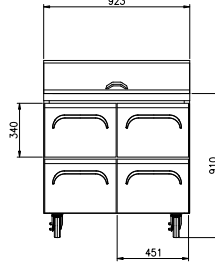

FMU-36-D4

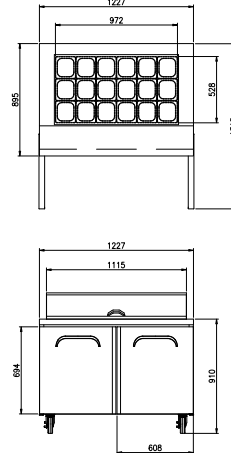

FMU-48

DRAWER MODEL

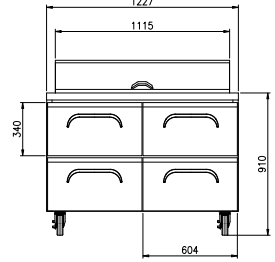

FMU-48-D4

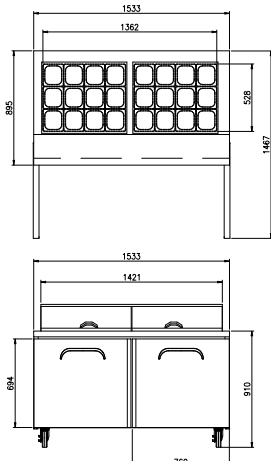

FMU-60

DRAWER MODEL

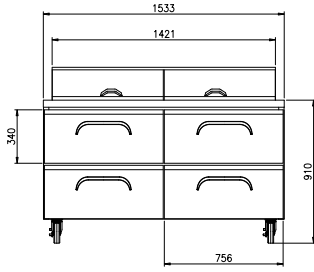

FMU-60-D4

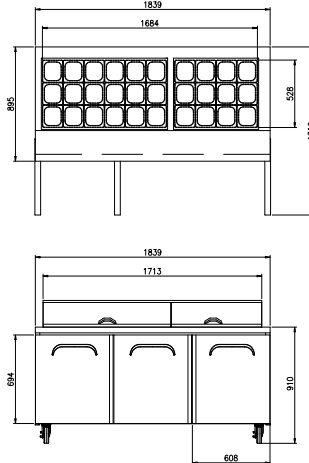

FMU-72

DRAWER MODEL

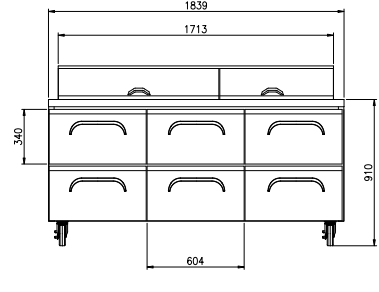

FMU-72-D6

SIDE PLAN

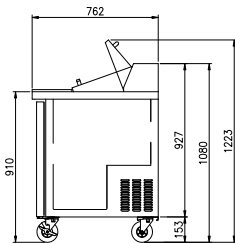

DRAWER MODEL

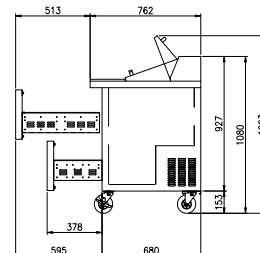

Model	Capacity (l)	Exterior Dimension (mm)			Net Weight (kg)	Gross Weight (kg)	Power Supply	Amps	Watt	HP	Refrigerant	No. Door	No. Pans (1/6")
		W	D	H									
FMU-28	186	699	895	1,120	76	80	10A	2.0	320	1/5	R-134a	1	12
FMU-36	252	923	895	1,120	92	98	10A	2.0	320	1/5	R-134a	2	15
FMU-48	346	1,227	895	1,120	112	120	10A	3.2	340	3/8	R-134a	2	18
FMU-60	441	1,533	895	1,120	126	136	10A	3.2	340	3/8	R-134a	2	24
FMU-72	531	1,839	895	1,120	147	160	10A	3.2	340	3/8	R-134a	3	30
FMU-28-D2	186	699	895	1,120	90	94	10A	2.0	320	1/5	R-134a		12
FMU-36-D4	252	923	895	1,120	114	120	10A	2.0	320	1/5	R-134a		15
FMU-48-D4	346	1,227	895	1,120	138	146	10A	3.2	340	3/8	R-134a		18
FMU-60-D4	441	1,533	895	1,120	156	166	10A	3.2	340	3/8	R-134a		24
FMU-72-D6	531	1,839	895	1,120	187	200	10A	3.2	340	3/8	R-134a		30

RPEP TABLE

SLIDE TOP PREP TABLE



FST-48



FST-60



FST-72

PREP TABLE

FEATURES

- Auto-closing doors & stopper
- 8mm polycarbonate made transparent slides
- Stainless steel finished front, sides and doors
- Locking dividers
- PE coated sturdy wire shelve
- Rear-mount compessor for enhanced airflow
- Airflow over the pans
- 5" casters (brakes at front)
- Accomocates 15cm deep pan
- * Food pans are NOT included

TEMPERATURE

- 0°C ~ 5°C

OPTIONAL MODELS

- 3" or 4" casters

PLAN VIEWS & SPECIFICATIONS

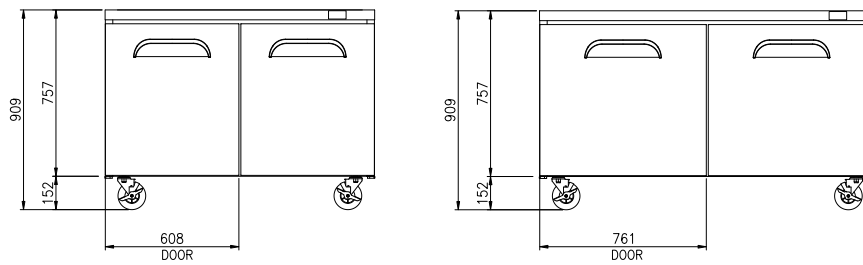
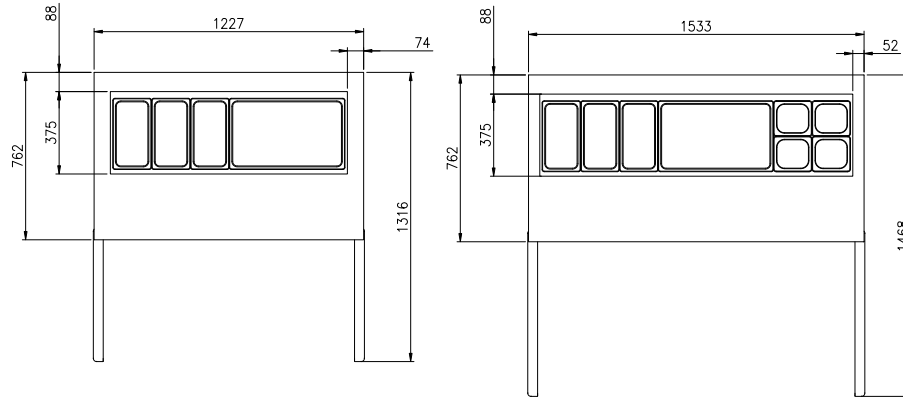

FST-48

FST-60

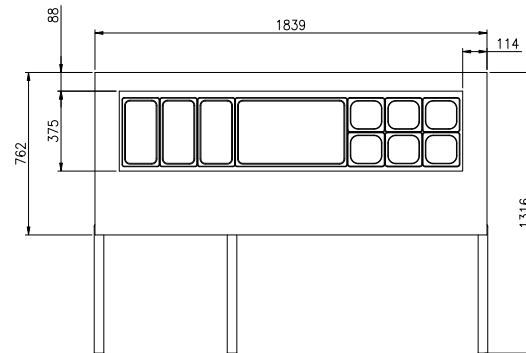

SIDE PLAN

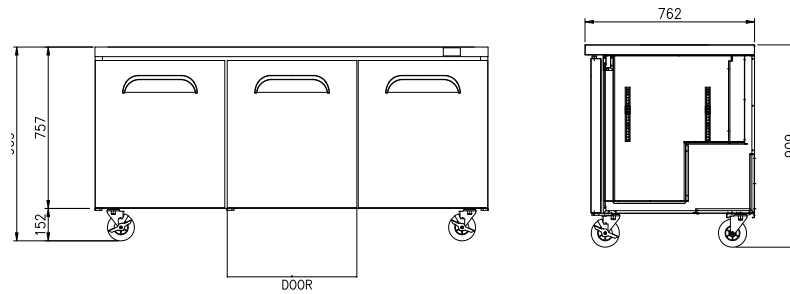

FST-72

Model	Capacity (l)	Exterior Dimension (mm)			Net Weight (kg)	Gross Weight (kg)	Power Supply	Amps	Watt	HP	Refrigerant	No. Slide	No. Door	No. Pans (1/6")
		W	D	H										
FST-48	346	1,227	762	909	106	114	10A	3.2	340	3/8	R-134a	2	2	12
FST-60	441	1,533	762	909	116	126	10A	3.2	340	3/8	R-134a	3	2	16
FST-72	531	1,839	762	909	135	148	10A	3.2	340	3/8	R-134a	3	3	18

RPEP TABLE

GLASS CANOPY SALAD PREP TABLE

PREP TABLE



FSU-48GC



FMU-48GC



FSU-60GC



FMU-60GC



FSU-72GC



FMU-72GC

FETURES

- Auto-closing doors & stopper
- Magnetic door gasket
- 8mm tempered glass canopy
- Locking dividers
- 244mm reversible cutting board
- PE coated sturdy wire shelves

- Rear-mount comperssor for enhanced airflow
- Airflow over the pans
- 5" casters (brakes at front)
- Accommodates 15cm deep pan
- Fully stainless steel finished cabinet
- * Food pans are NOT included

TEMPERATURE

- 0°C ~ 5°C

OPTIONAL MODELS

- 3" or 4" casters

PLAN VIEWS & SPECIFICATIONS

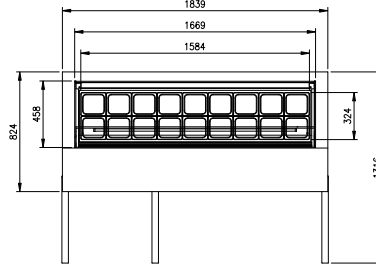
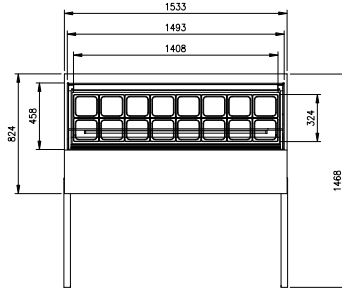
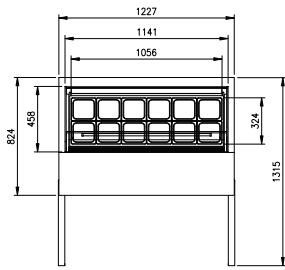

SIDE PLAN

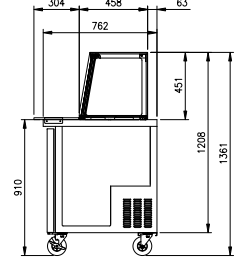
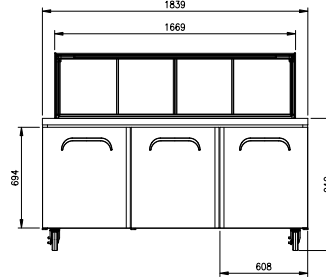
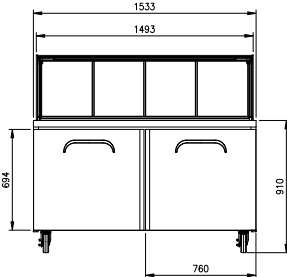
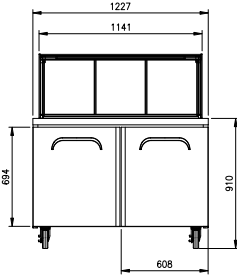

FSU-48GC

FSU-60GC

FSU-72GC

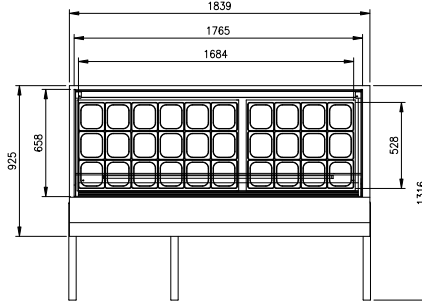
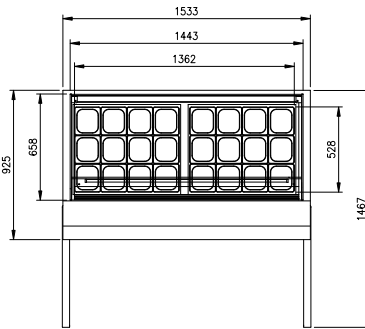
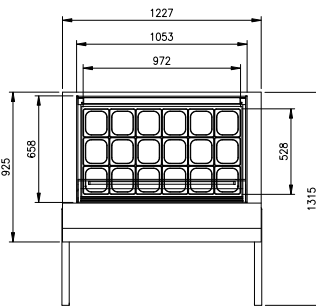

SIDE PLAN

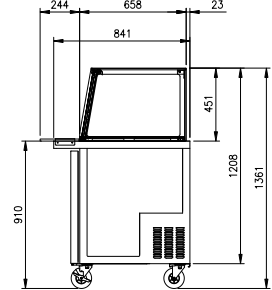
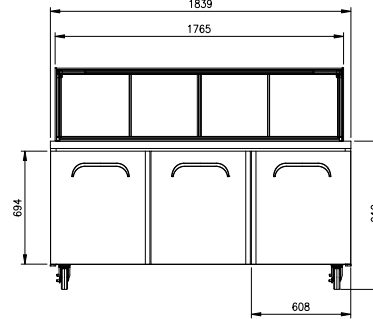
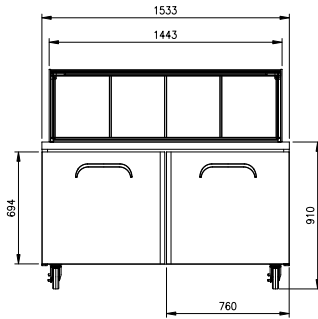
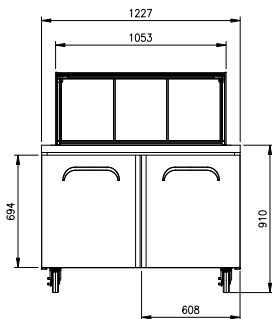

FMU-48GC

FMU-60GC

FMU-72GC

RPEP TABLE

Model	Capacity (l)	Exterior Dimension (mm)			Net Weight (kg)	Gross Weight (kg)	Power Supply	Amps	Watt	HP	Refrigerant	LED Lamp Watt	No. Door	Glass Slide Door	No. Pans (1/6")
		W	D	H											
FSU-48GC	346	1,227	824	1,361	132	152	10A	3.2	374	3/8	R-134a	12	2	3	12
FSU-60GC	441	1,533	824	1,361	148	173	10A	3.2	378	3/8	R-134a	18	2	4	16
FSU-72GC	531	1,839	824	1,361	168	196	10A	3.2	403	3/8	R-134a	21	3	4	18
FMU-48GC	346	1,227	925	1,361	139	159	10A	3.2	374	3/8	R-134a	12	2	3	18
FMU-60GC	441	1,533	925	1,361	164	189	10A	3.2	378	3/8	R-134a	18	2	4	24
FMU-72GC	531	1,839	925	1,361	191	219	10A	3.2	403	3/8	R-134a	21	3	4	30

OPEN AIR SALAD TABLE



FTTB-900R



FTTB-1200R



FTTB-1500R



FTTB-1800R

PREP TABLE

FEATURES

- Auto-closing doors & stopper
- Magnetic door gasket
- Locking dividers
- PVC coated sturdy wire shelves
- Digital temperature control & monitor system
- 3" casters (brake at front)
- Accommodates full-size pan with any depth
- Stainless steel finished top, front, sides and doors
- * Food pans and lids are NOT included

TEMPERATURE

- 0°C ~ 5°C

OPTIONAL MODELS

- 4" or 5" casters

PLAN VIEWS & SPECIFICATIONS

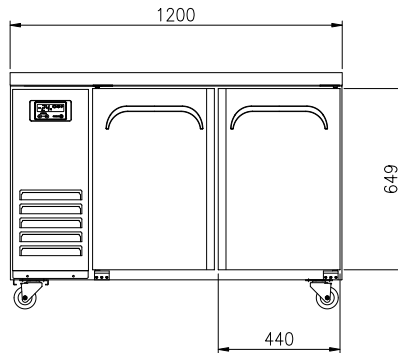
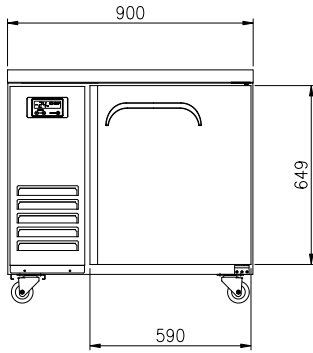
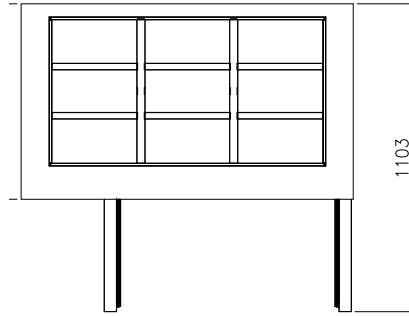
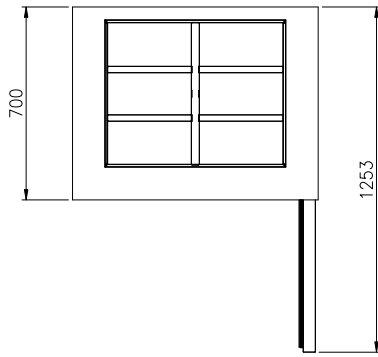

SIDE PLAN

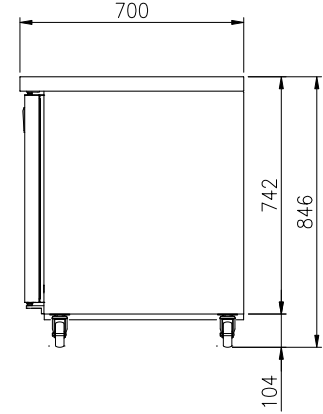

FTTB-900R

FTTB-1200R

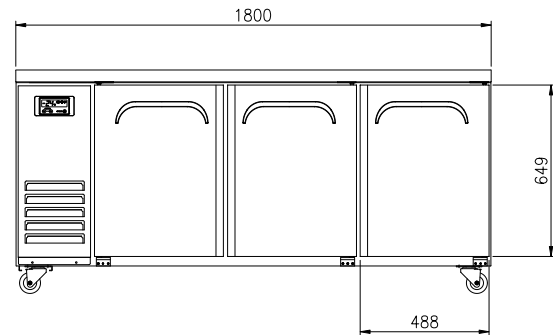
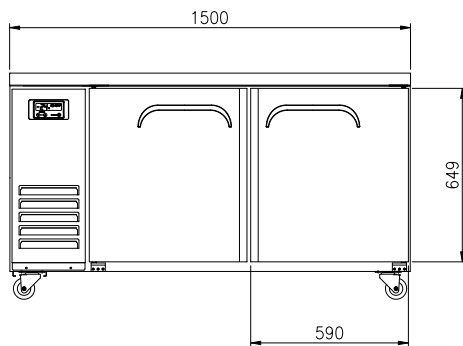
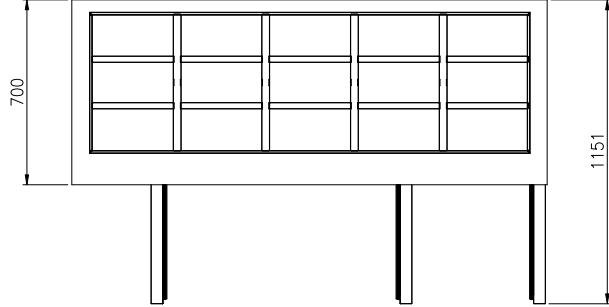
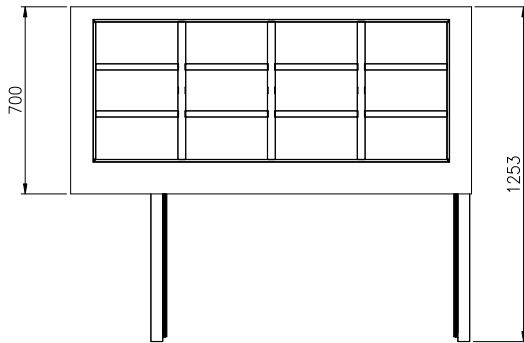

FTTB-1500R

FTTB-1800R

RPEP TABLE

Model	Capacity (l)	Exterior Dimension (mm)			Net Weight (kg)	Gross Weight (kg)	Power Supply	Amps	Watt	HP	Refrigerant	No. Door	No. Pans (1/3")
		W	D	H									
FTTB-900R	202	900	700	846	59	64	10A	2.0	340	1/3	R-134a	1	6
FTTB-1200R	292	1,200	700	846	76	84	10A	2.0	340	1/3	R-134a	2	9
FTTB-1500R	336	1,500	700	846	81	91	10A	2.0	340	1/3	R-134a	2	12
FTTB-1800R	468	1,800	700	846	91	104	10A	2.0	340	1/3	R-134a	3	15

PIZZA PREP TABLE



FPT-44



FPT-67



FPT-93

DRAWER MODELS



FPT-44-D2



FPT-67-D2



FPT-93-D6

GRILL MODELS



FPT-44G



FPT-67G



FPT-93G

FEATURES

- Auto-closing doors & stopper
- Magnetic door gasket
- Stainless steel hood lid covers
- Locking dividers
- 480mm reversible cutting board
- PE coated sturdy wire shelves

- Rear-mount compressor for enhanced airflow
- 4" casters (brakes at front)
- Accommodates 15cm deep pan
- Stainless steel finished top, front, sides and doors
- * Food pans are NOT included

TEMPERATURE

- 0°C ~ 5°C

OPTIONAL MODELS

- Drawer mixed model (custom-made)
- 3" or 5" casters

PLAN VIEWS & SPECIFICATIONS

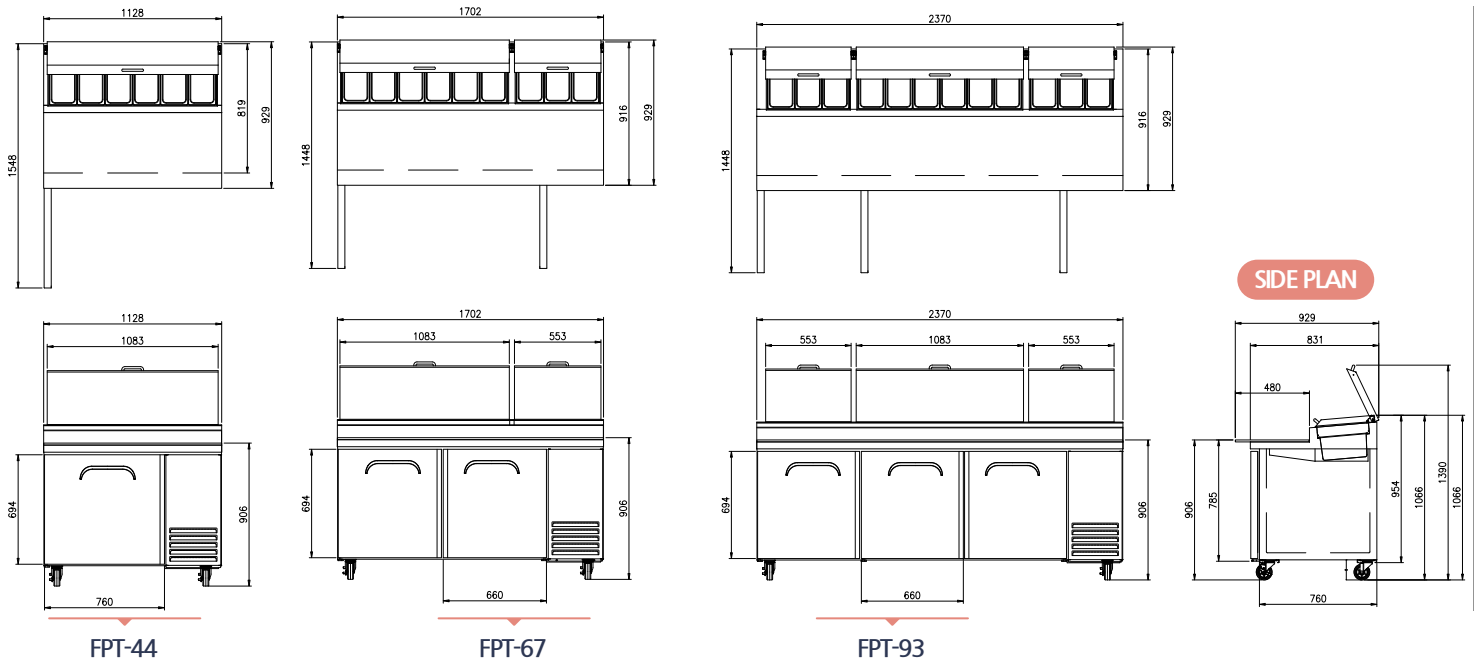

DRAWER MODELS

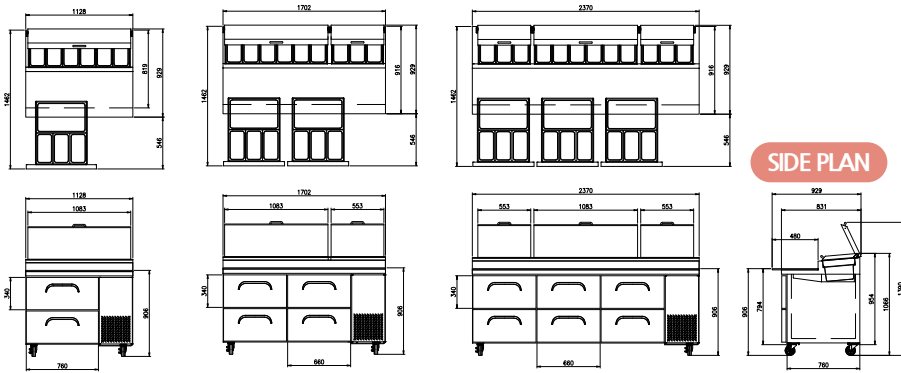

GRILL MODELS

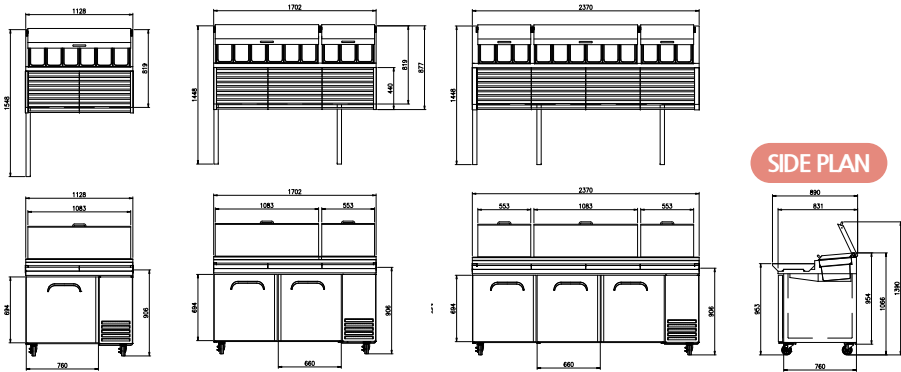

Model	Capacity (l)	Exterior Dimension (mm)			Net Weight (kg)	Gross Weight (kg)	Power Supply	Amps	Watt	HP	Refrigerant	No. Door/Drawer	No. Pans (1/3")
		W	D	H									
FPT-44	320	1,128	929	1,066	130	138	10A	3.2	380	3/8	R-134a	1	6
FPT-67	572	1,702	929	1,066	167	180	10A	3.2	380	3/8	R-134a	2	9
FPT-93	872	2,370	929	1,066	205	223	10A	3.8	790	1/2	R-404A	3	12
FPT-44-D2	320	1,128	929	1,066	145	153	10A	3.2	380	3/8	R-134a	2	6
FPT-67-D4	572	1,702	929	1,066	192	205	10A	3.2	380	3/8	R-134a	4	9
FPT-93-D6	872	2,370	929	1,066	247	265	10A	3.8	790	1/2	R-404A	6	12

RPEP TABLE

NARROW PIZZA PREP TABLE



FTT-900



FTT-1200

PREP TABLE



FTT-1500



FTT-1800

FEATURES

- Auto-closing doors & stopper
- Magnetic door gasket
- Stainless steel hood lid covers
- Locking dividers
- PVC coated sturdy wire shelves
- 3" casters (brakes at front)
- Accommodates 15cm deep pan
- Stainless steel finished top, front, sides and doors
- Stainless hood lid
- * Food pans are NOT included

TEMPERATURE

- 0°C ~ 5°C

OPTIONAL MODELS

- Leg model available
- 4" or 5" casters

PLAN VIEWS & SPECIFICATIONS

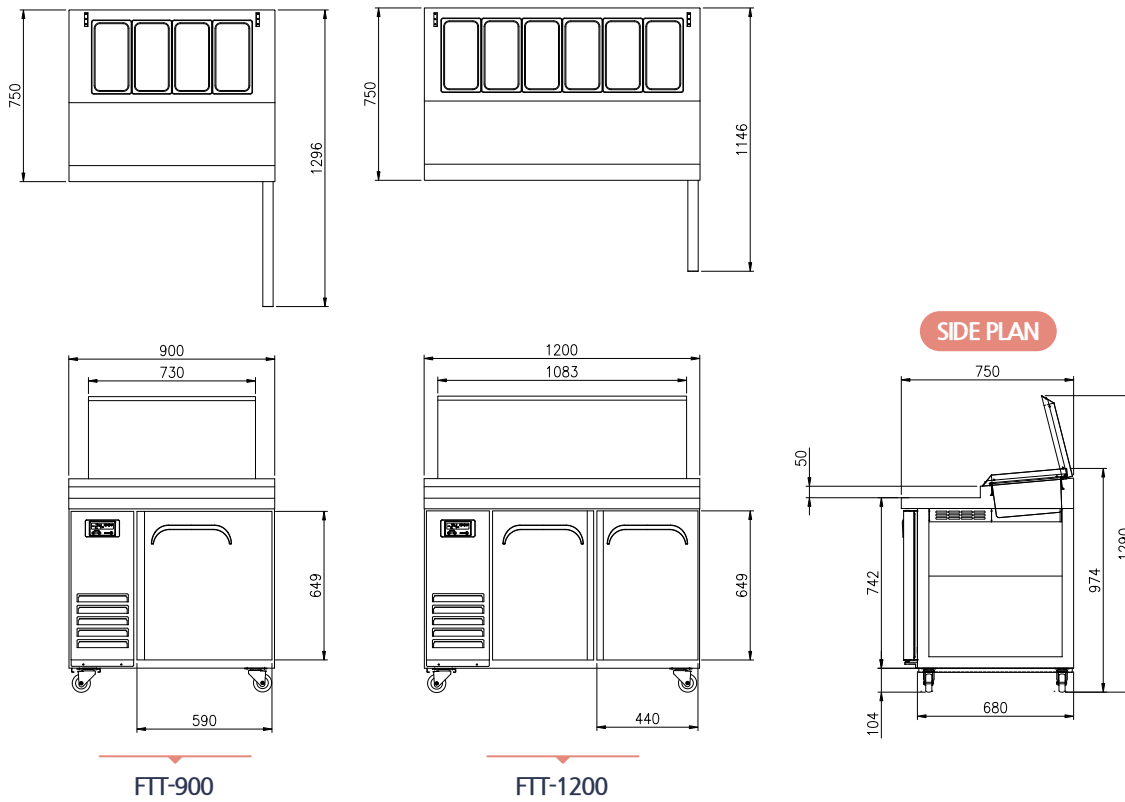

FTT-900

FTT-1200

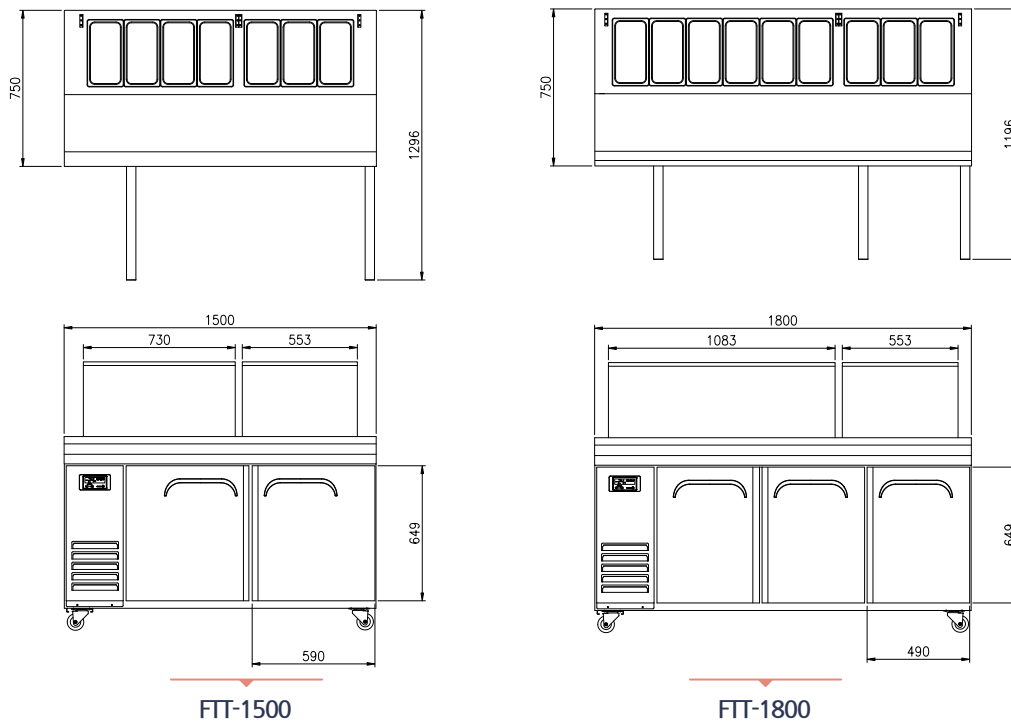

FTT-1500

FTT-1800

Model	Capacity (ℓ)	Exterior Dimension (mm)			Net Weight (kg)	Gross Weight (kg)	Power Supply	Amps	Watt	HP	Refrigerant	No. Door	No. Pans (1/3")
		W	D	H									
FTT-900	200	900	750	974	75	86	10A	2.0	340	1/3	R-134a	1	4
FTT-1200	300	1,200	750	974	90	103	10A	2.0	340	1/3	R-134a	2	6
FTT-1500	412	1,500	750	974	100	115	10A	2.0	340	1/3	R-134a	2	7
FTT-1800	512	1,800	750	974	115	132	10A	2.0	340	1/3	R-134a	3	9



3

UNDER BENCH & CHEF BASE

Underbench

Underbench Drawer

Glass Door Underbench

Dual Temperature Underbench

3-Drawer Underbench

Rear Mount Underbench

Multi Temperature Underbench

Chef Base

UNDERBENCH



FT-900R
FT-900F



FT-1200R
FT-1200F



FT-1500R
FT-1500F



FT-1800R
FT-1800F



FT-2100R



FT-2400R

UNDERBENCH & CHEF BASE

FEATURES

- Digital temperature control & monitor system
- 3" casters (brakes at front)
- Fully stainless steel finished cabinet
- PE coated sturdy wire shelves
- Auto-closing doors & stopper
- Door pressure release device
- Magnetic door gasket

TEMPERATURE

- Fridge: 0°C ~ 5°C
- Freezer: -18°C

OPTIONAL MODELS

- Leg model available
- 4" or 5" casters
- 600mm depth model (only for fridge)

PLAN VIEWS & SPECIFICATIONS

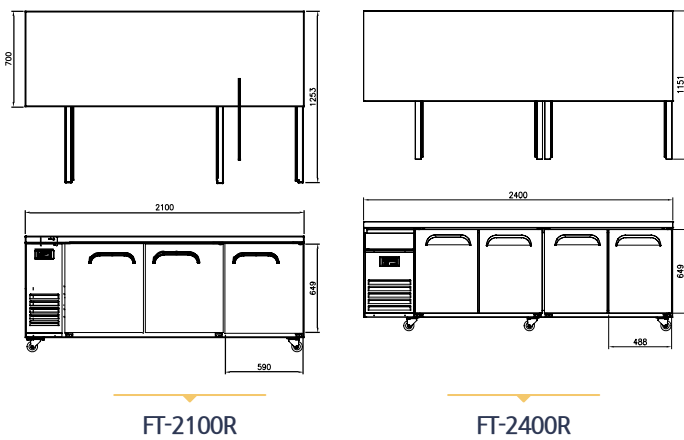
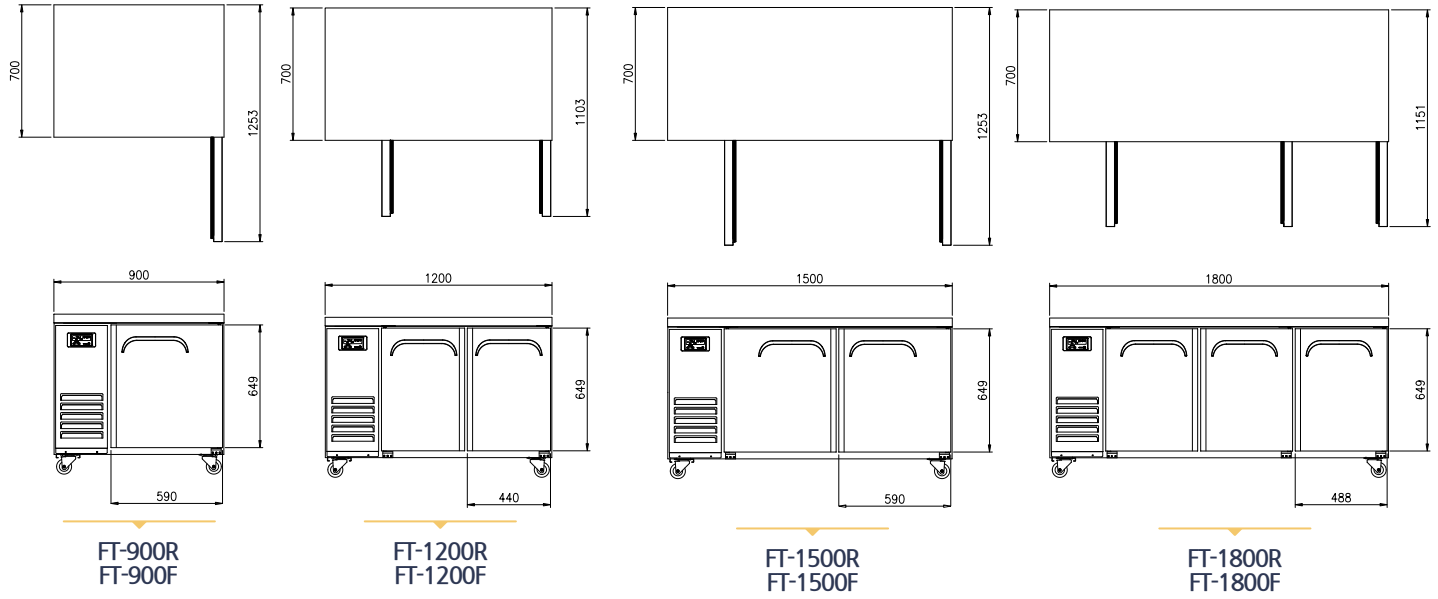

SIDE PLAN

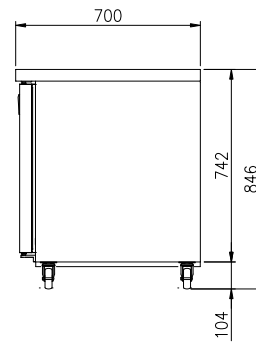

600mm DEPTH MODEL

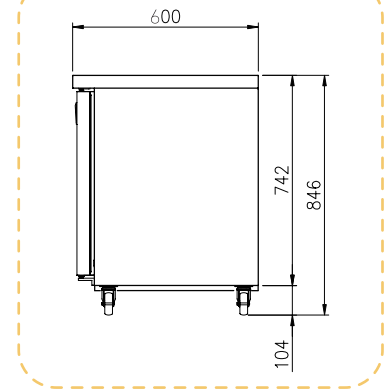

UNDERBENCH & CHEF BASE

* D : Deforst

Model	Capacity (l)	Exterior Dimension (mm)			Net Weight (kg)	Gross Weight (kg)	Power Supply	Amps	Watt	HP	Refrigerant	No. Doors
		W	D	H								
FT-900R	186	900	700 (600)	846	61	66	10A	2.0	340	1/3	R-134a	1
FT-1200R	293	1,200	700 (600)	846	78	86	10A	2.0	340	1/3	R-134a	2
FT-1500R	402	1,500	700 (600)	846	84	94	10A	2.0	340	1/3	R-134a	2
FT-1800R	509	1,800	700 (600)	846	95	108	10A	2.0	340	1/3	R-134a	3
FT-2100R	612	2,100	700	846	105	116	10A	2.0	340	1/3	R-134a	3
FT-2400R	640	2,400	700	846	128	140	10A	2.0	340	1/3	R-134a	4
FT-900F	186	900	700	846	64	69	10A	3.0	380(D:520)	3/8	R-134a	1
FT-1200F	293	1,200	700	846	81	89	10A	3.0	380(D:520)	3/8	R-134a	2
FT-1500F	342	1,500	700	846	87	97	10A	3.0	380(D:520)	3/8	R-134a	2
FT-1800F	509	1,800	700	846	95	108	10A	6.0	890(D:520)	1/2	R-404A	3

UNDERBENCH DRAWER



FT-900R-D2
FT-900F-D2



FT-1200R-D4
FT-1200F-D4



FT-1500R-D4
FT-1500F-D4



FT-1800R-D6



FT-2400R-D4

UNDERBENCH & CHEF BASE

FETURES

- Telescoping drawer slide
- Drawer can hold up to 40kg
- Accommodates full-size pan up to 15cm depth
- * Food pans are NOT included

- Digital temperature control & monitor system
- 3" casters (brakes at front)
- Fully stainless steel finished cabinet

TEMPERATURE

- Fridge: 0°C ~ 5°C
- Freezer: -18°C

OPTIONAL MODELS

- Leg model available
- 4" or 5" casters

PLAN VIEWS & SPECIFICATIONS

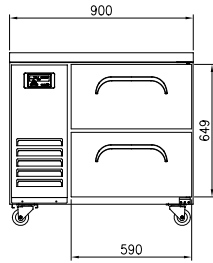
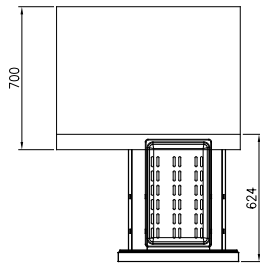

FT-900R-D2
FT-900F-D2

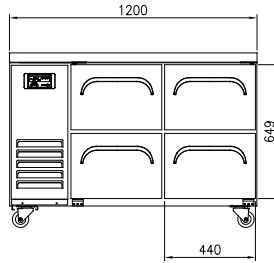
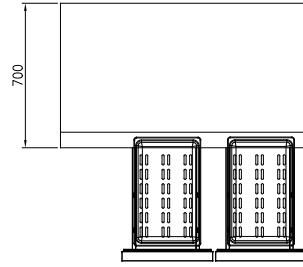

FT-1200R-D4
FT-1200F-D4

SIDE PLAN

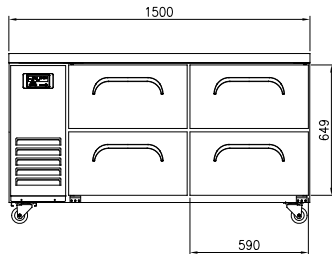
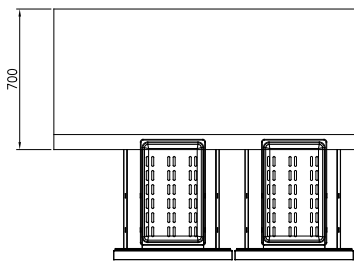
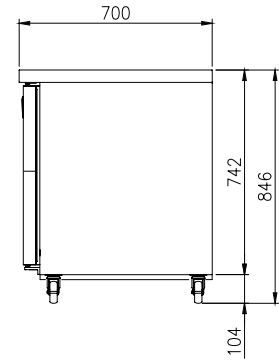

FT-1500R-D4
FT-1500F-D4

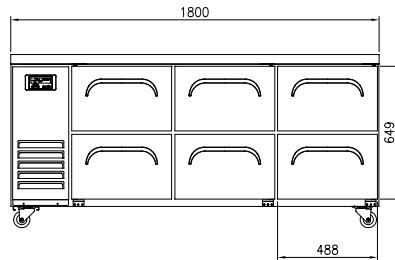
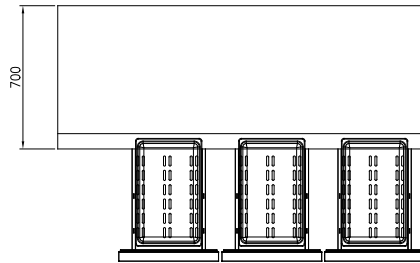

FT-1800R-D6

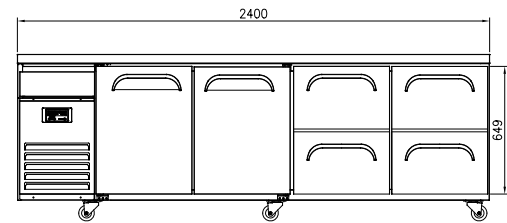
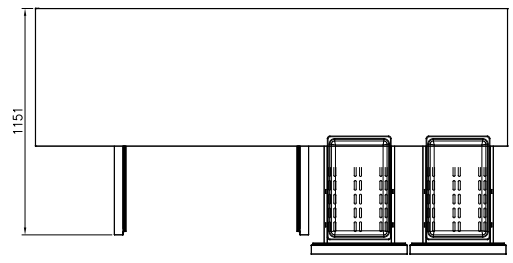

FT-2400R-D4

UNDERBENCH & CHEF BASE

* D : Deforst

Model	Capacity (l)	Exterior Dimension (mm)			Net Weight (kg)	Gross Weight (kg)	Power Supply	Amps	Watt	HP	Refrigerant	No. Drawer
		W	D	H								
FT-900R-D2	186	900	700	846	61	66	10A	2.0	340	1/3	R-134a	2
FT-1200R-D4	293	1,200	700	846	78	86	10A	2.0	340	1/3	R-134a	4
FT-1500R-D4	402	1,500	700	846	84	94	10A	2.0	340	1/3	R-134a	4
FT-1800R-D6	509	1,800	700	846	95	108	10A	2.0	340	1/3	R-134a	6
FT-900F-D2	186	900	700	846	64	69	10A	3.0	380(D:520)	3/8	R-134a	2
FT-1200F-D4	293	1,200	700	846	81	89	10A	3.0	380(D:520)	3/8	R-134a	4
FT-1500F-D4	342	1,500	700	846	87	97	10A	3.0	380(D:520)	3/8	R-134a	4
FT-2400R-D4	640	2,400	700	846	139	151	10A	2.0	340	1/3	R-134a	2/4

GLASS DOOR UNDERBENCH

UNDERBENCH & CHEF BASE



FT-900RG



FT-1200RG



FT-1500RG



FT-1800RG

FEATURES

- Auto-closing doors & stopper
- Door pressure release device
- Magnetic door gasket
- Extra-large internal capacity
- Front breating
- Tempered glass
- Digital temperature control & monitor system
- 3" casters (brakes at front)
- LED lighting interior
- Fully stainless steel finished cabinet
- PE coated sturdy wire shelves

TEMPERATURE

- 0°C ~ 5°C

OPTIONAL MODELS

- Leg model available
- 4" or 5" casters

PLAN VIEWS & SPECIFICATIONS

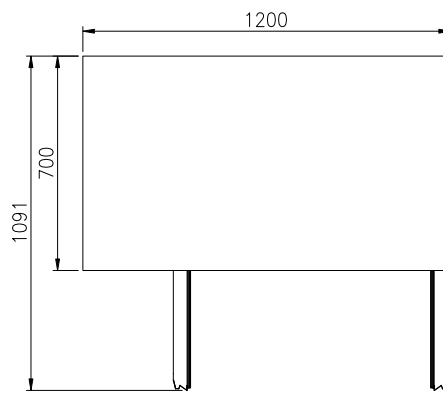
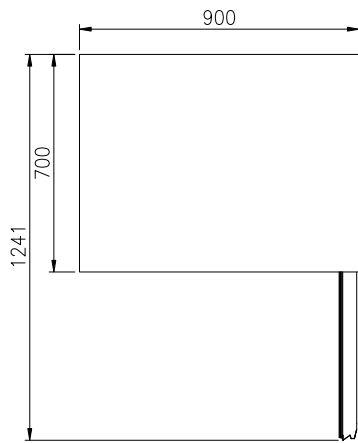

SIDE PLAN

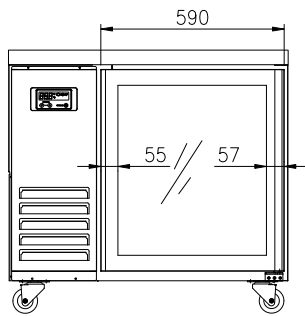

FT-900RG

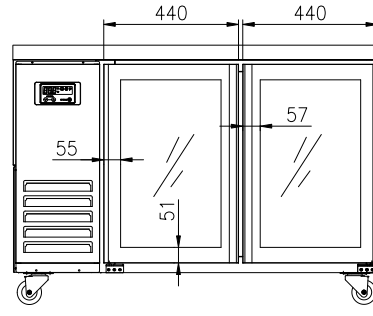

FT-1200RG

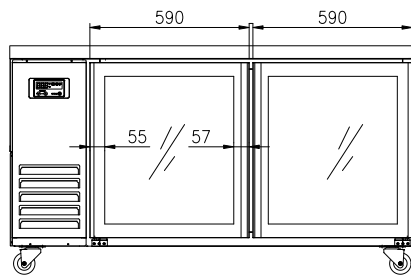
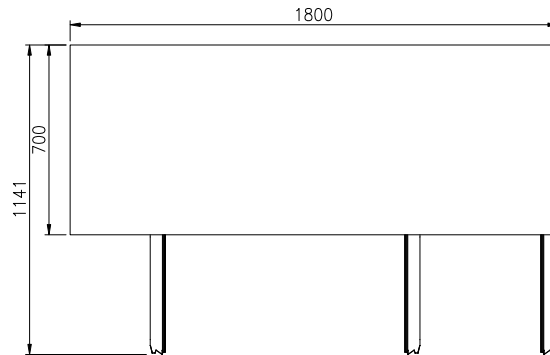
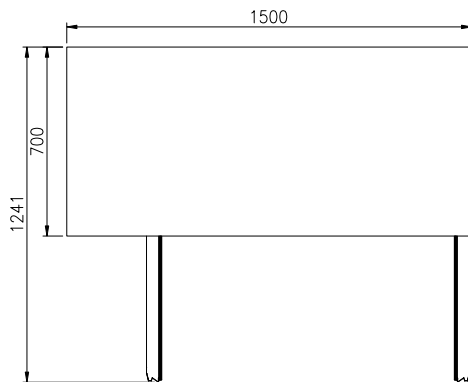
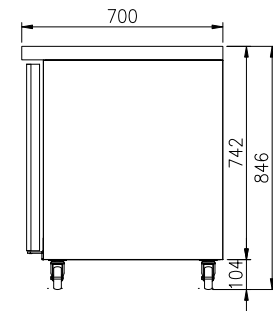

FT-1500RG

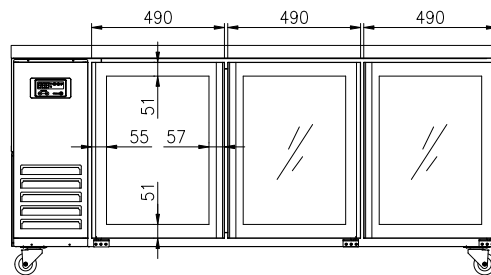

FT-1800RG

UNDERBENCH & CHEF BASE

Model	Capacity (ℓ)	Exterior Dimension (mm)			Net Weight (kg)	Gross Weight (kg)	Power Supply	Amps	Watt	HP	Refrigerant	No. Door
		W	D	H								
FT-900RG	186	900	700	846	61	66	10A	2.0	360	1/3	R-134a	1
FT-1200RG	293	1,200	700	846	78	86	10A	2.0	360	1/3	R-134a	2
FT-1500RG	402	1,500	700	846	84	94	10A	2.0	380	1/3	R-134a	2
FT-1800RG	509	1,800	700	846	95	108	10A	2.0	380	1/3	R-134a	3

DUAL TEMPERATURE UNDERBENCH

UNDERBENCH & CHEF BASE



FT-1200RF



FT-1500RF



FT-1800RF

FEATURES

- Auto-closing doors & stopper
- Door pressure release device
- Magnetic door gasket
- Extra-large internal capacity
- Digital temperature control & monitor system
- 3" casters (brakes at front)
- Fully stainless steel finished cabinet
- PE coated sturdy wire shelves

TEMPERATURE

- Fridge: 0°C ~ 5°C
- Freezer: -18°C

OPTIONAL MODELS

- Leg model
- 4" or 5" casters

PLAN VIEWS & SPECIFICATIONS

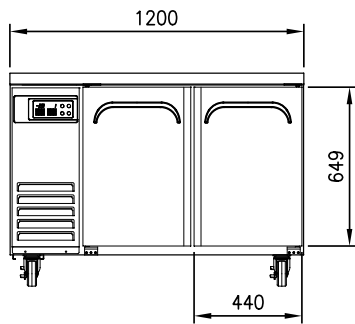
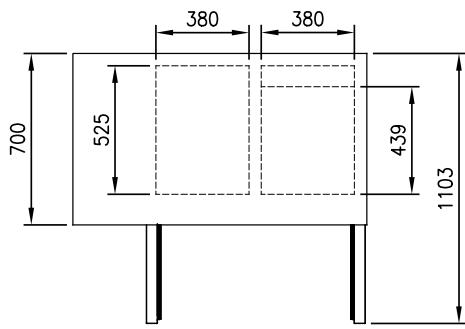

FT-1200RF

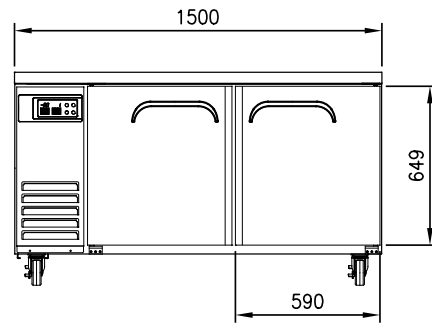
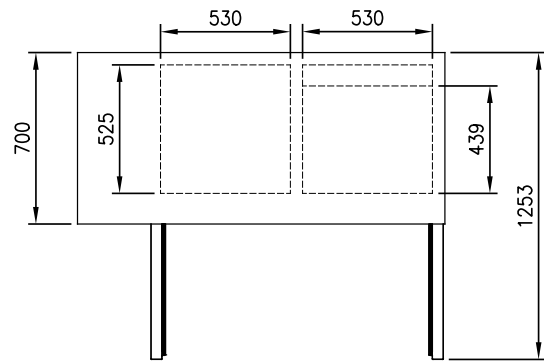

FT-1500RF

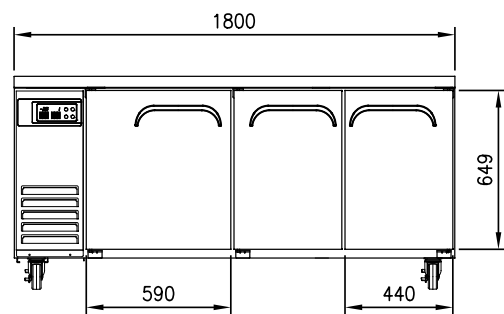
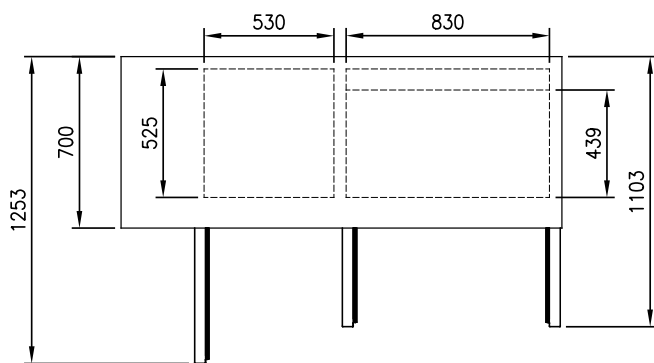

FT-1800RF

SIDE PLAN

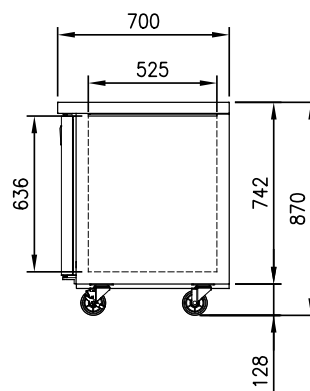

UNDERBENCH & CHEF BASE

* D : Deforst

Model	Capacity (ℓ)		Exterior Dimension (mm)			Net Weight (kg)	Gross Weight (kg)	Power Supply	Amps	Watt	HP	Refrigerant	No. Doors
	Ref.	Fre.	W	D	H								
FT-1200RF	107	124	1,200	700	846	83	91	10A	3.0	390(D:620)	3/8	R-134a	2
FT-1500RF	455	177	1,500	700	846	94	104	10A	3.0	390(D:620)	3/8	R-134a	2
FT-1800RF	241	177	1,800	700	846	108	121	10A	3.0	390(D:620)	3/8	R-134a	3

3-DRAWER UNDERBENCH



FDU-1200



FDU-1500



FDU-1800

UNDERBENCH & CHEF BASE

FEATURES

- Telescoping drawer slide
- Drawer can hold up to 40kg
- Accommodates full-size pan up to 15cm depth
- * Food pans are NOT included
- Digital temperature control & monitor system
- 3" casters (brakes at front)
- Fully stainless steel finished cabinet

TEMPERATURE

- 0°C ~ 5°C

OPTIONAL MODELS

- 4" or 5" casters
- Leg model available

PLAN VIEWS & SPECIFICATIONS

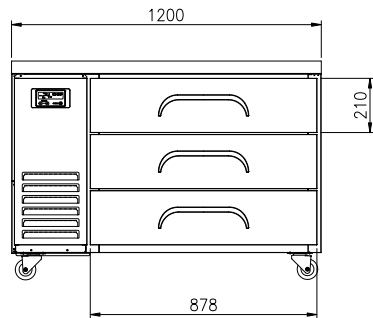
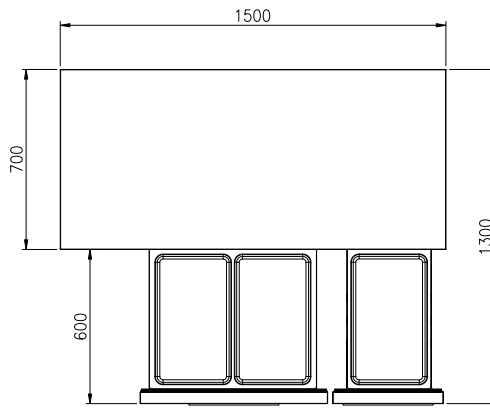
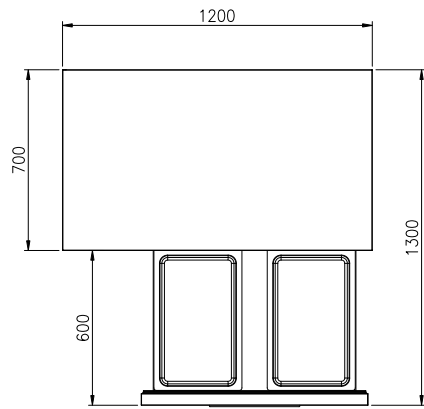

FDU-1200

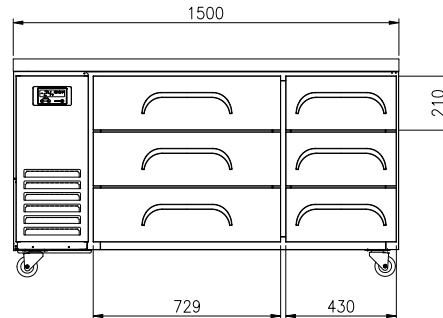

FDU-1500

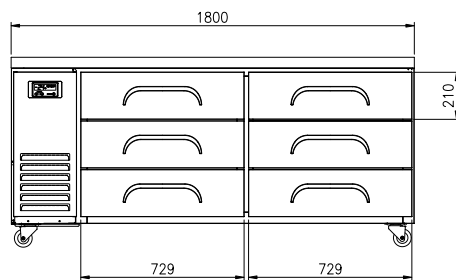
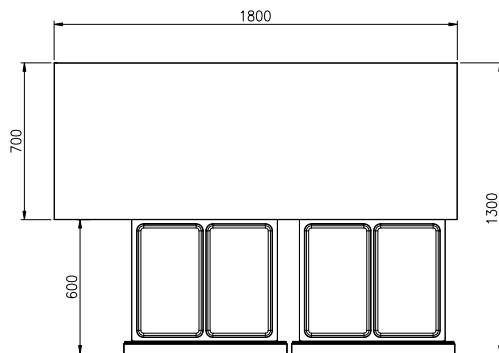

FDU-1800

SIDE PLAN

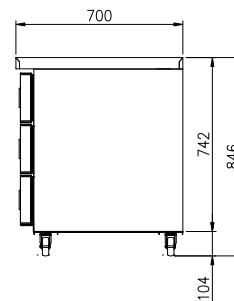

UNDERBENCH & CHEF BASE

Model	Capacity (l)	Exterior Dimension (mm)			Net Weight (kg)	Gross Weight (kg)	Power Supply	Amps	Watt	HP	Refrigerant	No. Doors	No. Pans (1/1")
		W	D	H									
FDU-1200	286	1,200	700	845	96	103	10A	1.8	320	1/5	R-134a	3	6
FDU-1500	388	1,500	700	845	120	128	10A	2.0	340	1/3	R-134a	6	9
FDU-1800	489	1,800	700	845	140	153	10A	2.0	340	1/3	R-134a	6	12

REAR MOUNT UNDERBENCH



FUR-28
FUF-28



FUR-36
FUF-36



FUR-48
FUF-48



FUR-60
FUF-60



FUR-72

UNDERBENCH & CHEF BASE

DRAWER MODELS



SPLASH BACK MODELS



FEATURES

- Auto-closing doors & stopper
- Magnetic door gasket
- Locking dividers
- Stainless steel hood lid covers
- Stainless steel finished top, front, sides and doors
- PE coated sturdy wire shelves
- Rear-mount compressor for enhanced air flow
- 5" casters (brakes at front)
- Accommodates 15cm deep pan
- * Food pans are NOT included

TEMPERATURE

- Fridge: 0°C ~ 5°C
- Freezer: -18°C

OPTIONAL MODELS

- Drawer model
- 3" or 4" casters
- Splash back model (worktop)

PLAN VIEWS & SPECIFICATIONS

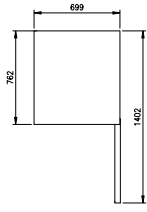

DRAWER MODEL

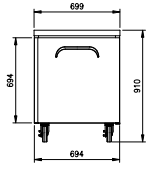

FUR-28 / FUF-28

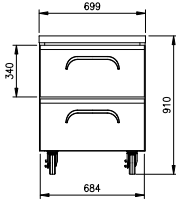

FUR-28-D2 / FUF-28-D2

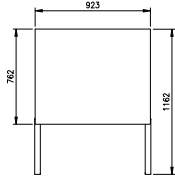

DRAWER MODEL

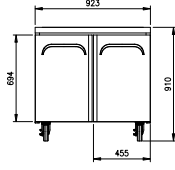

FUR-36 / FUF-36

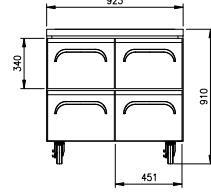

FUR-36-D4 / FUF-36-D4

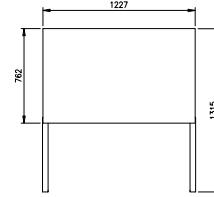

DRAWER MODEL

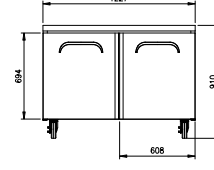

FUR-48 / FUF-48

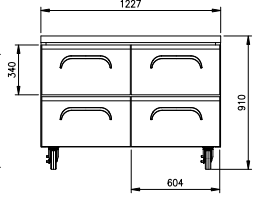

FUR-48-D4

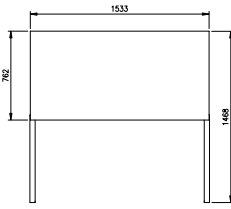

DRAWER MODEL

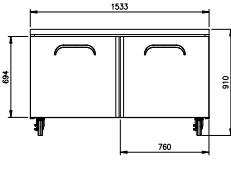

FUR-60 / FUF-60

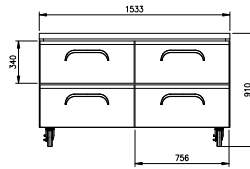

FUR-60-D4

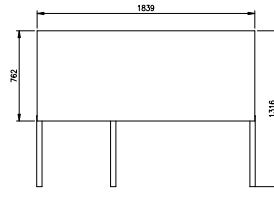

DRAWER MODEL

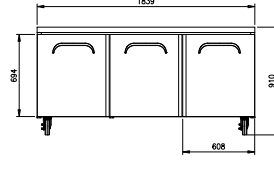

FUR-72

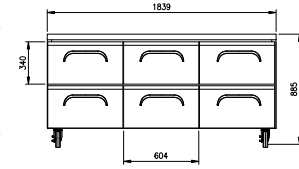

FUR-72-D6

DOOR MODEL

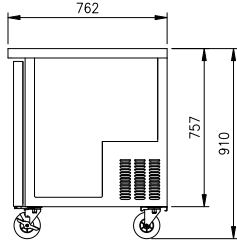

DRAWER MODEL

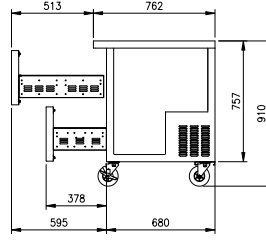

SPLASH BACK MODEL

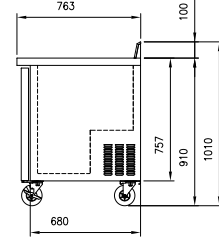

* H* : Height for splash back model * D : Deforst

Model	Capacity (ℓ)	Exterior Dimension (mm)				Net Weight (kg)	Gross Weight (kg)	Power Supply	Amps	Watt	HP	Refrigerant	No. Shelves	No. Door / Drawer
		W	D	H	H*									
FUR-28	186	699	762	910	1,010	61	65	10A	2.0	320	1/5	R-134a	1	1
FUR-36	252	923	762	910	1,010	77	82	10A	2.0	320	1/5	R-134a	2	2
FUR-48	346	1,227	762	910	1,010	95	103	10A	2.0	340	1/5	R-134a	2	2
FUR-60	441	1,533	762	910	1,010	105	115	10A	3.2	340	3/8	R-134a	2	2
FUR-72	531	1,839	762	910	1,010	121	134	10A	3.2	340	3/8	R-134a	3	3
FUF-28	186	699	762	910	1,010	65	69	10A	2.8	360(D:344)	3/8	R-134a	1	1
FUF-36	252	923	762	910	1,010	82	87	10A	3.8	640(D:344)	1/2	R-404A	2	2
FUF-48	346	1,227	762	910	1,010	100	108	10A	3.8	800(D:550)	1/2	R-404A	2	2
FUF-60	441	1,533	762	910	1,010	115	125	10A	3.8	800(D:550)	1/2	R-404A	2	2
FUR-28-D2	186	699	762	910	1,010	75	79	10A	2.0	320	1/5	R-134a	2	2
FUR-36-D4	252	923	762	910	1,010	99	104	10A	2.0	320	1/5	R-134a	4	4
FUR-48-D4	346	1,227	762	910	1,010	121	129	10A	2.0	340	1/5	R-134a	4	4
FUR-60-D4	441	1,533	762	910	1,010	135	145	10A	3.2	340	3/8	R-134a	4	4
FUR-72-D6	531	1,839	762	910	1,010	161	174	10A	3.2	340	3/8	R-134a	6	6
FUF-28-D2	186	699	762	910	1,010	65	69	10A	2.8	360(D:344)	3/8	R-134a	1	2

MUTI TEMPERATURE UNDERBENCH

UNDERBENCH & CHEF BASE

DOOR MODEL



FDW-06RF

FETURES

- Telescoping drawer slide
- Drawer with bottom panel
- Drawer can hold up to 40kg
- Recessed drawer handle
- Compact size for tight space

- Digital temperature control & monitor system
- Convert from fridge to freezer
- Legs are standard
- Fully stainless steel finished cabinet

TEMPERATURE

--18°C ~ 5°C

OPTIONAL MODELS

- Door model

PLAN VIEWS & SPECIFICATIONS

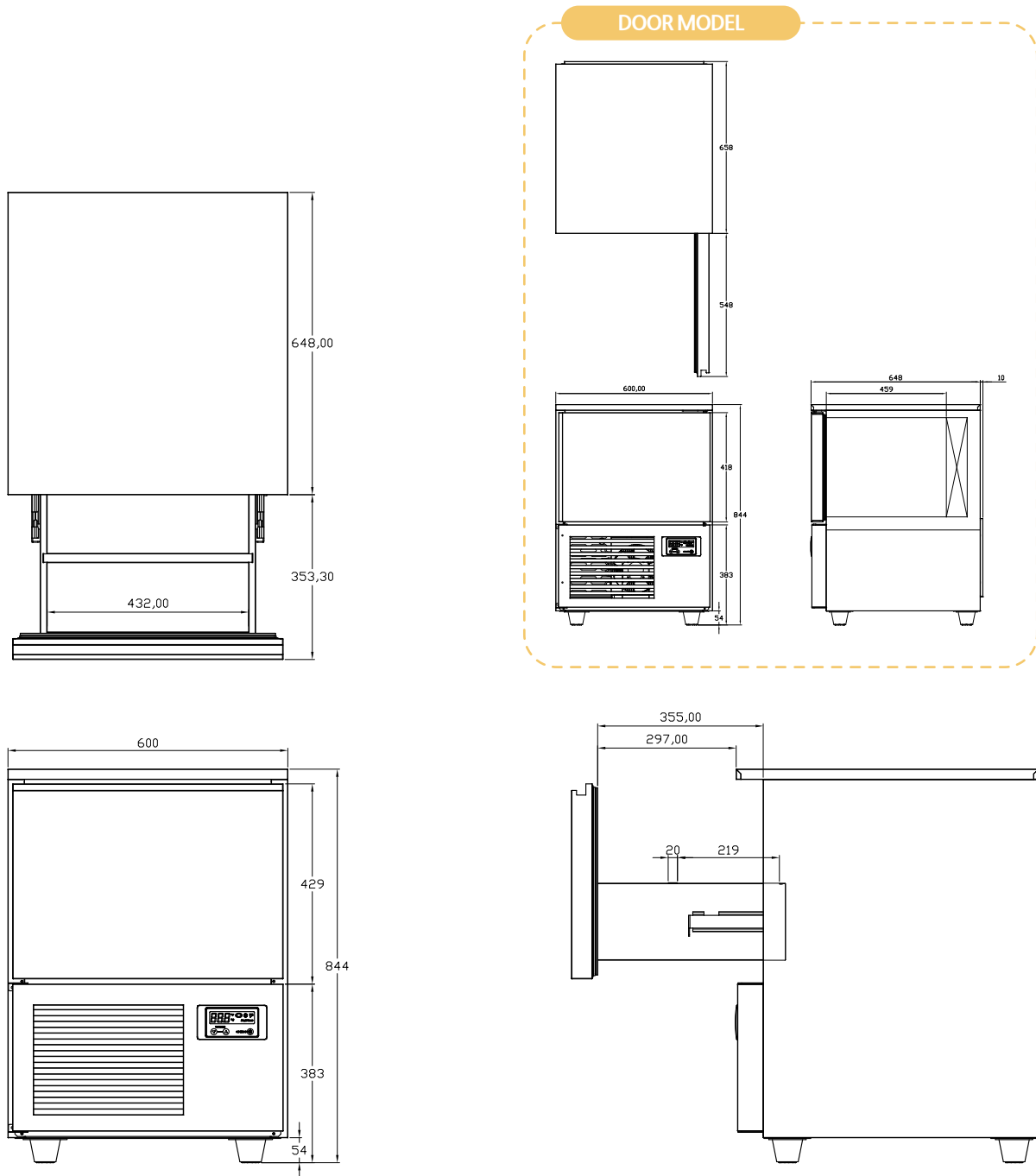

UNDERBENCH & CHEF BASE

FDW-06RF

Model	Capacity (ℓ)	Exterior Dimension (mm)			Net Weight (kg)	Gross Weight (kg)	Power Supply	Amps	Watt	HP	Refrigerant	No. Drawer
		W	D	H								
FDW-06RF	91	600	648	844	56	58	10A	3	360	3/8	R-134a	1

CHEF BASE



FDC-1200



FDC-1500



FDC-1800

UNDERBENCH & CHEF BASE

FEATURES

- Telescoping drawer slide
- Drawer can hold up to 40kg
- Accommodates full-size pan up to 15cm depth
- * Food pans are NOT included

- Digital temperature control & monitor system
- 3" casters (brakes at front)
- Fully stainless steel finished cabinet

TEMPERATURE

- 0°C ~ 5°C

OPTIONAL MODELS

- 4" or 5" casters
- Leg model available

PLAN VIEWS & SPECIFICATIONS

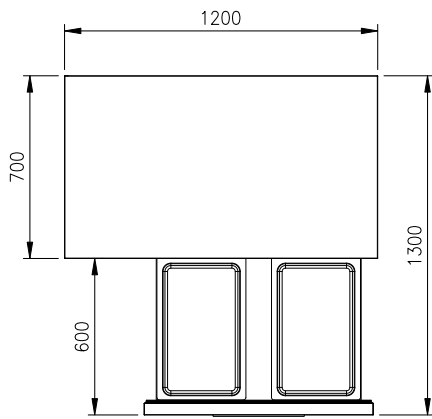

FDC-1200

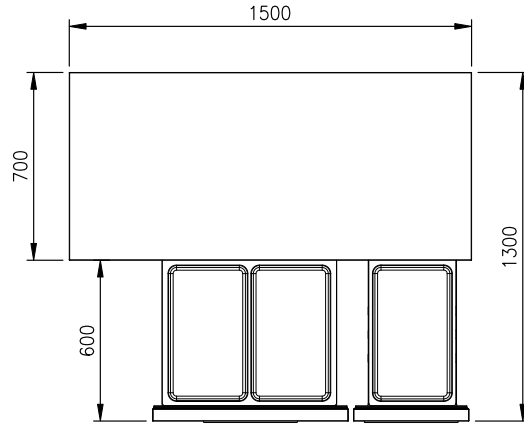

FDC-1500

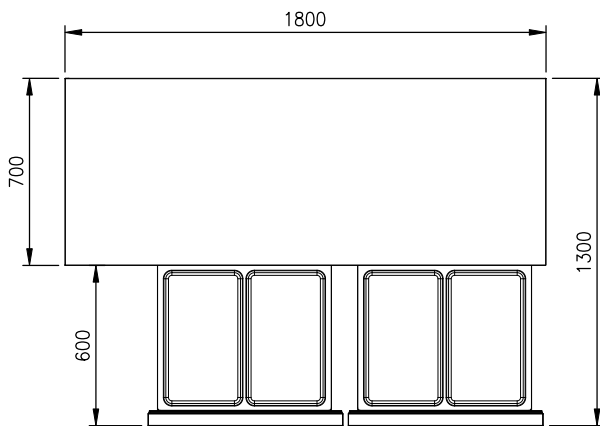
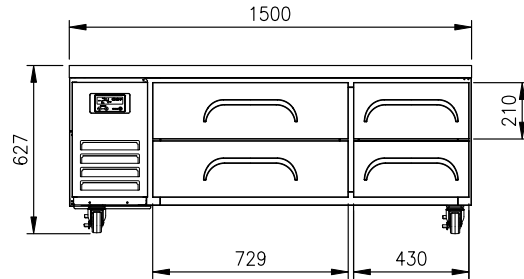
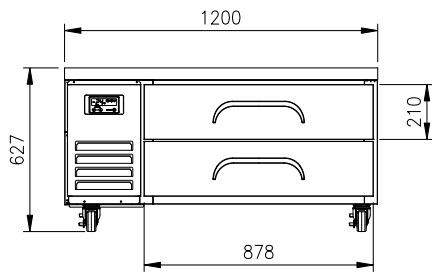

FDC-1800

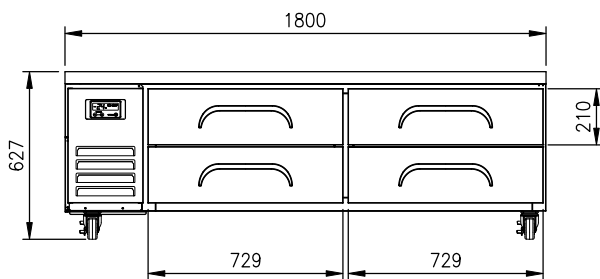

SIDE PLAN

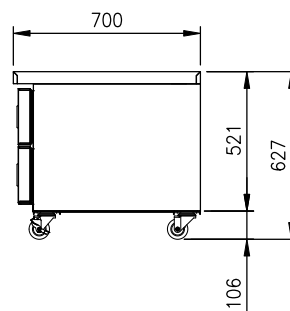

Model	Capacity (l)	Exterior Dimension (mm)			Net Weight (kg)	Amps	Power Supply	Watt	HP	Refrigerant	No. Drawer	No. Pan (1/1")
		W	D	H								
FDC-1200	190	1,200	700	627	93	1.8	10A	320	1/5	R-134a	2	4
FDC-1500	257	1,500	700	627	116	1.8	10A	320	1/5	R-134a	4	6
FDC-1800	324	1,800	700	627	135	1.8	10A	320	1/5	R-134a	4	8



4

BAR EQUIP MENT

Beer Dispenser

Bottle Cooler

Back Bar

Countertop Fridge

BEER DISPENSER



FBD-23B



FBD-59B



FBD-69B



FBD-80B



FBD-90B



FBD-95B

BAR EQUIPMENT

FEATURES

- Door locks standard
- Magnetic door gasket
- Cabinet space for beer kegs
- Stainless finished top

- Accommodates 3" diameter beer tower
- * Towers are NOT included
- 4" casters with brakes

TEMPERATURE

- 0°C ~ 5°C

OPTIONAL MODELS

- Stainless exterior
- Glass door model (with LED light)
- 3" or 5" casters

PLAN VIEWS & SPECIFICATIONS

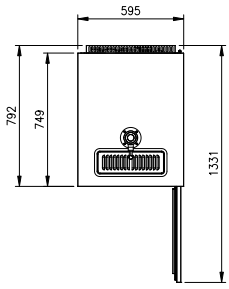

SIDE PLAN

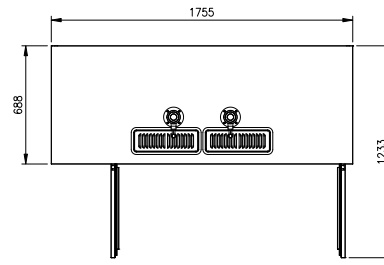
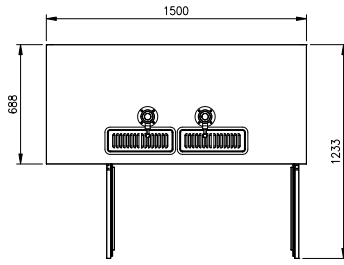

SIDE PLAN

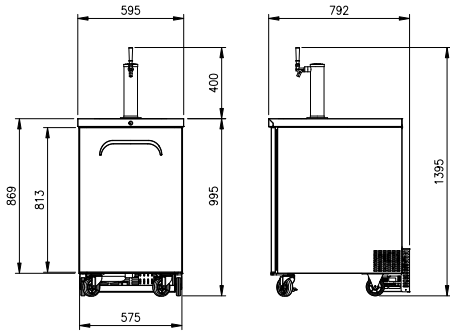

FBD-23B

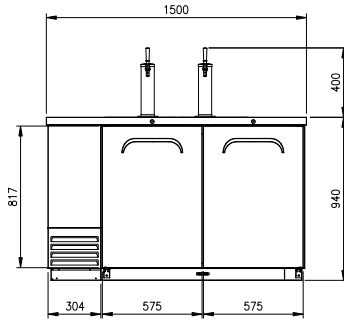

FBD-59B

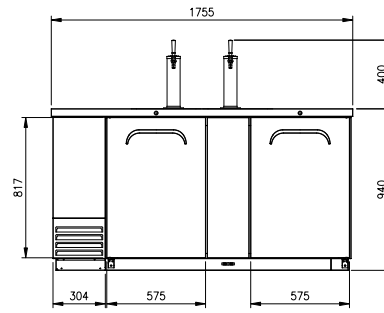

FBD-69B

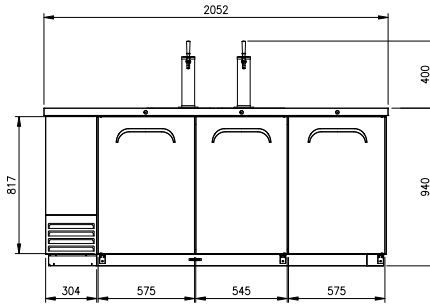
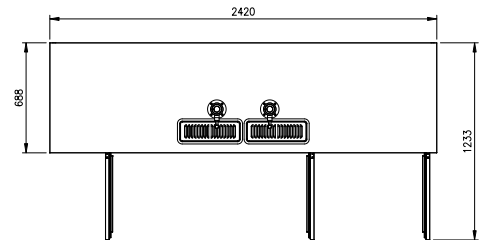
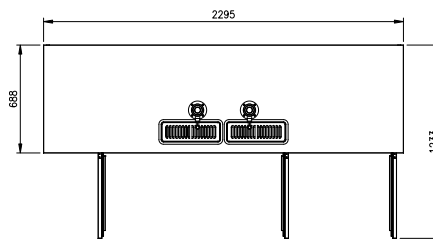
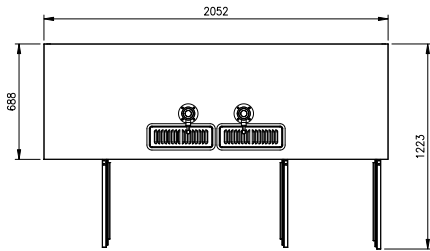
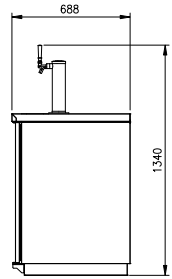

FBD-80B

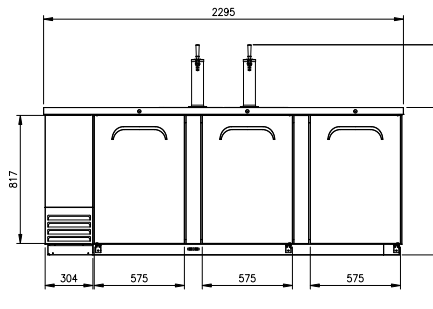

FBD-90B

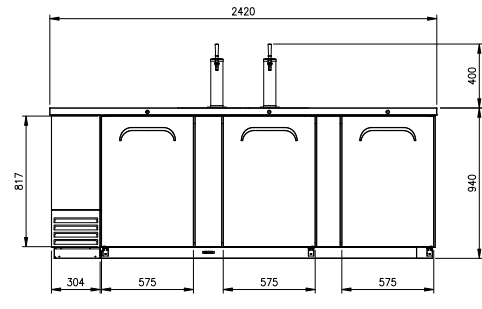

FBD-95B

BAR EQUIPMENT

The height includes 4" caster (126mm)

Model	Capacity (ℓ)	Exterior Dimension (mm)			Net Weight (kg)	Gross Weight (kg)	Amps	Power Supply	Watt	HP	Refrigerant	No. Door	No. Tower
		W	D	H									
FBD-23B	224	595	792	995	57	60	2.0	10A	320	1/5	R134a	1	1
FBD-59B	549	1,500	688	1,066	98	107	2.8	10A	360	3/8	R134a	2	2
FBD-69B	663	1,755	688	1,066	109	120	2.8	10A	360	3/8	R134a	2	2
FBD-80B	790	2,052	688	1,066	124	137	2.8	10A	360	3/8	R134a	3	2
FBD-90B	895	2,295	688	1,066	135	150	3.4	10A	360	3/8	R134a	3	2
FBD-95B	951	2,420	688	1,066	141	157	3.4	10A	360	3/8	R134a	3	2

BOTTLE COOLER



FBC-36B



FBC-50B



FBC-65B



FBC-80B



FBC-95B

BAR EQUIPMENT

FETURES

- Door locks standard
- Stainless grip handles
- Cabinet space for bottles and cans
- PE coated ad justable dividers
- Removable bottle cap opener and catcher
- Stainless finished top
- Stainless sliding lids

TEMPERATURE

- 0°C ~ 5°C

OPTIONAL MODELS

- Stainless exterior

PLAN VIEWS & SPECIFICATIONS

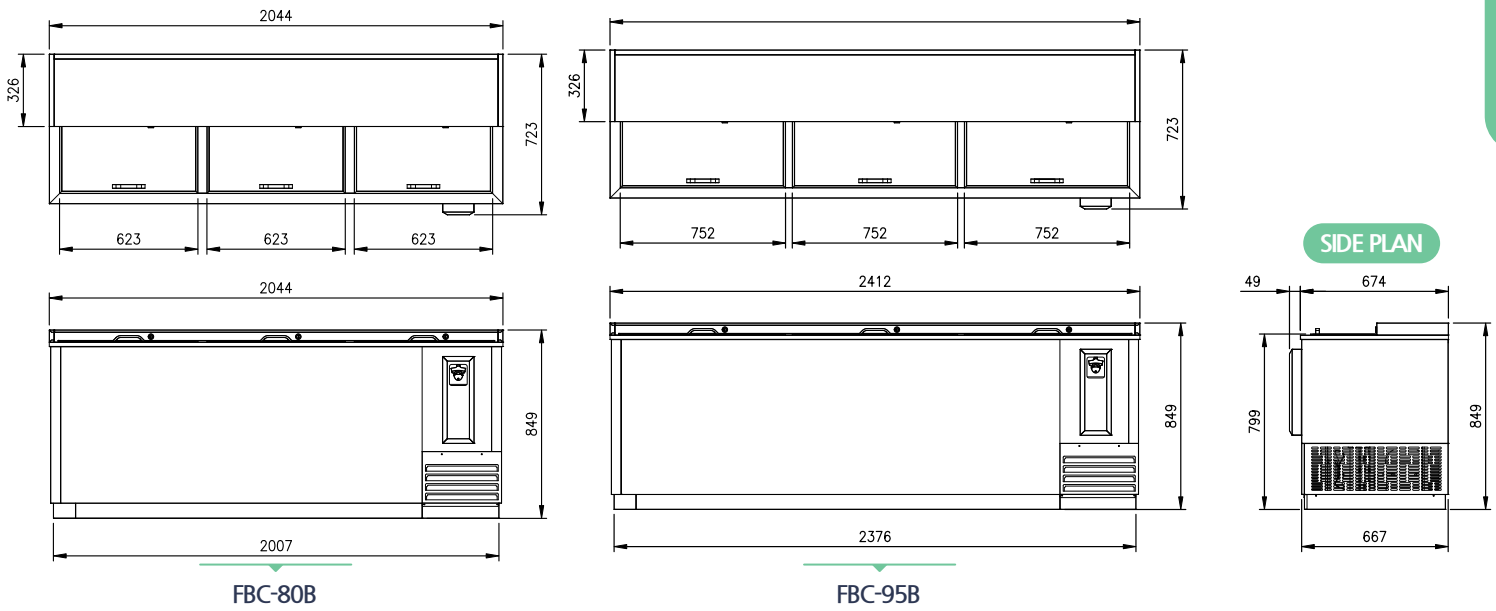
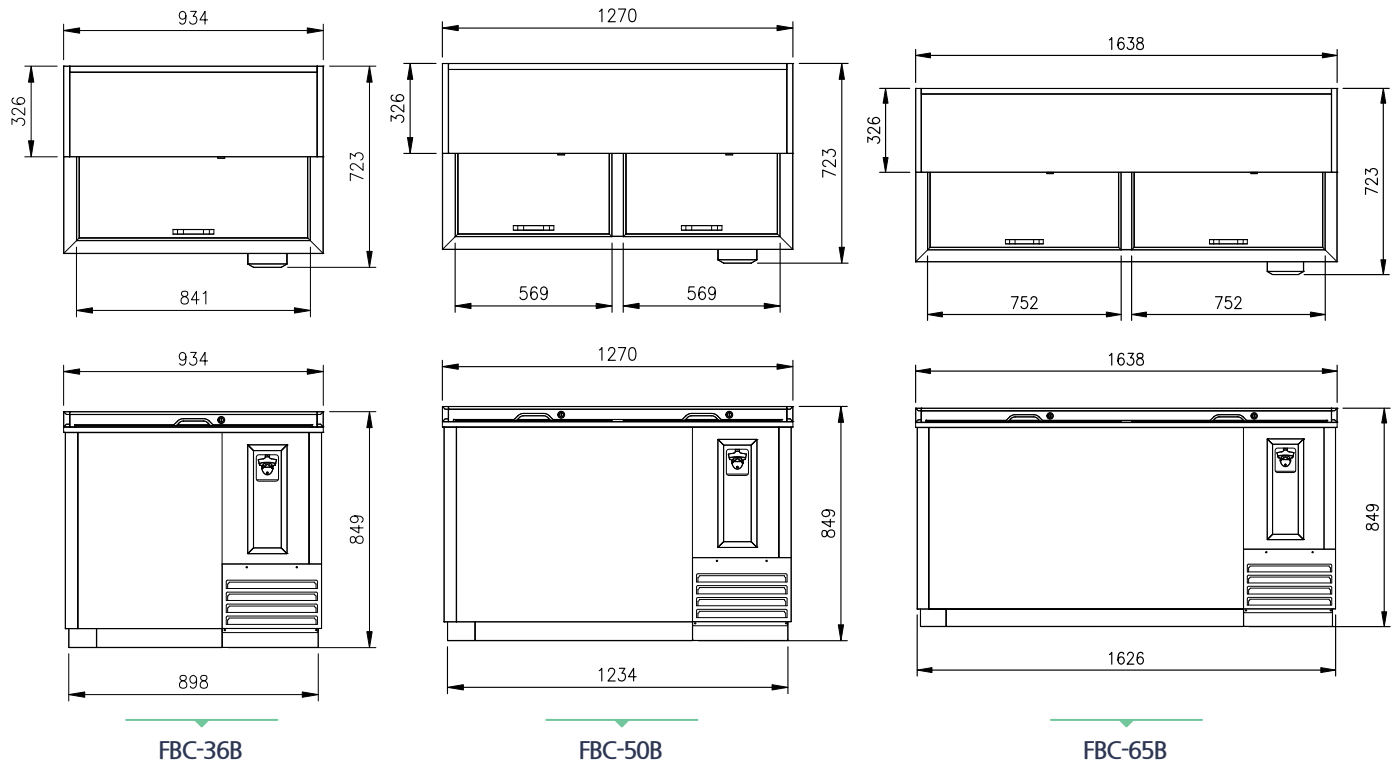

BAR EQUIPMENT

Model	Capacity (ℓ)	Exterior Dimension (mm)			Net Weight (kg)	Gross Weight (kg)	Amps	Power Supply	Watt	HP	Refrigerant	No. Divider	No. Slide
		W	D	H									
FBC-36B	280	934	723	849	58	64	2.0	10A	330	1/5	R134a	2	1
FBC-50B	419	1,270	723	849	89	97	3.4	10A	380	3/8	R134a	3	2
FBC-65B	569	1,638	723	849	104	114	3.4	10A	380	3/8	R134a	3	2
FBC-80B	736	2,044	723	849	124	135	3.4	10A	380	3/8	R134a	4	3
FBC-95B	886	2,412	723	849	137	152	3.4	10A	380	3/8	R134a	5	3

BACK BAR



FNB-48BG



FNB-60BG



FNB-72BG

BAR EQUIPMENT

SOLID DOOR MODEL



FEATURES

- Magnetic door gasket
- Stainless finished top
- LED lights
- PE coated sturdy wire shelves
- Digital temperature display
- 4" casters
- Accommodates door locks
- Stainless grip handles
- Cabinet space for bottles and cans
- Tempered glass door

TEMPERATURE

- 0°C ~ 5°C

OPTIONAL MODELS

- Solid door model
- Deep depth model
- 3" or 5" Caster model

PLAN VIEWS & SPECIFICATIONS

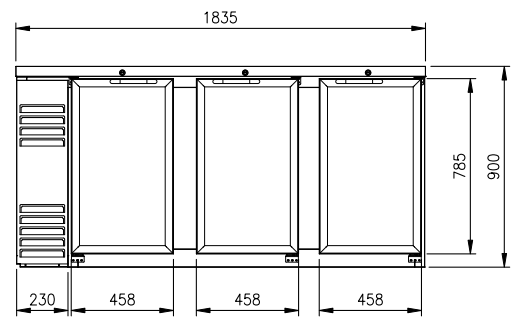
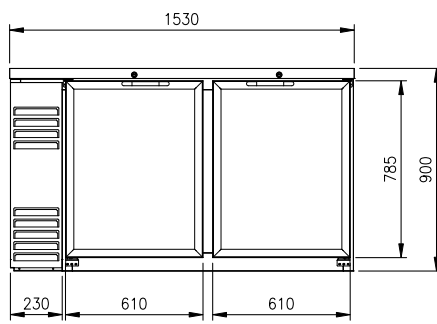
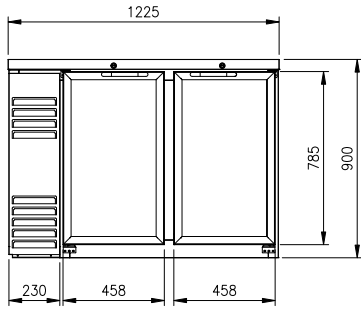
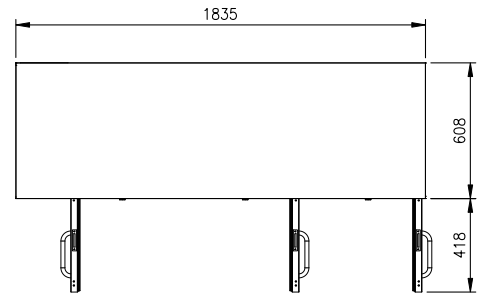
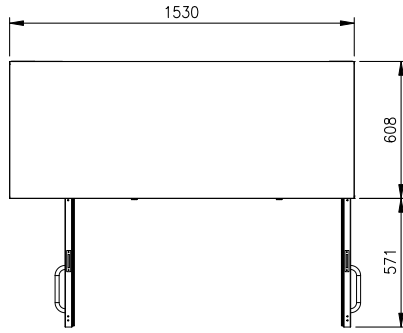
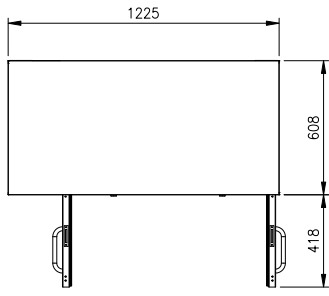

FNB-48

FNB-60

FNB-72

SOLID DOOR SIDE PLAN

GLASS DOOR SIDE PLAN

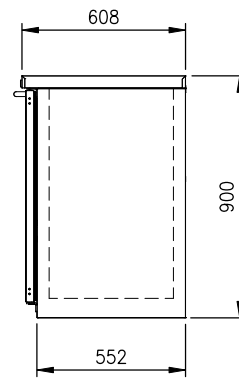
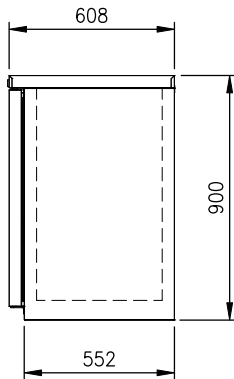

BAR EQUIPMENT

SOLID DOOR MODEL

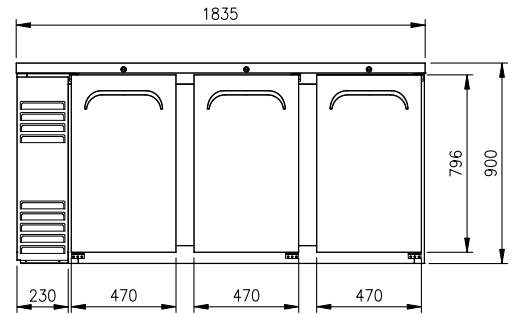
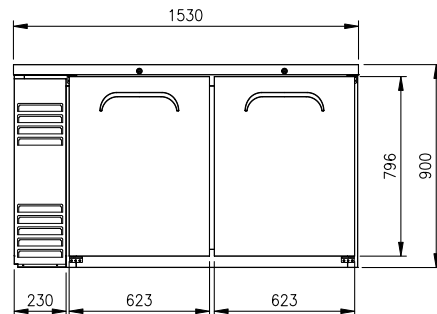
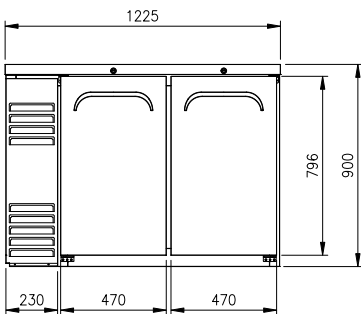

The height includes 4" caster (126mm)

Model	Capacity (ℓ)	Exterior Dimension (mm)			Net Weight (kg)	Gross Weight (kg)	Amps	Power Supply	Watt	HP	Refrigerant	No. Door
		W	D	H								
FNB-48BG	328	1,225	608	1,026	90	96	3.4	10A	380	3/8	R134a	2
FNB-60BG	442	1,530	608	1,026	102	111	3.4	10A	380	3/8	R134a	2
FNB-72BG	555	1,835	608	1,026	119	129	3.4	10A	380	3/8	R134a	3

COUNTERTOP FRIDGE



FCT-17RS

BAR EQUIPMENT

GLASS SIDE MODEL



FCT-17RG

WHITE MODEL



FCT-17RSW

FEATURES

- LED lights
- Stainless grip handles
- Cabinet space for bottles and cans
- PE coated sturdy wire shelves

TEMPERATURE

- 0°C ~ 5°C

OPTIONAL MODELS

- Glass side model (Tempered glass)
- White mode
- Door locks
- Lighted sign panel
- Casters

PLAN VIEWS & SPECIFICATIONS

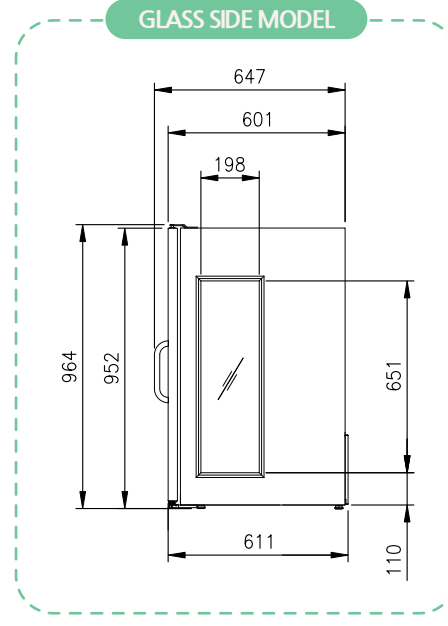
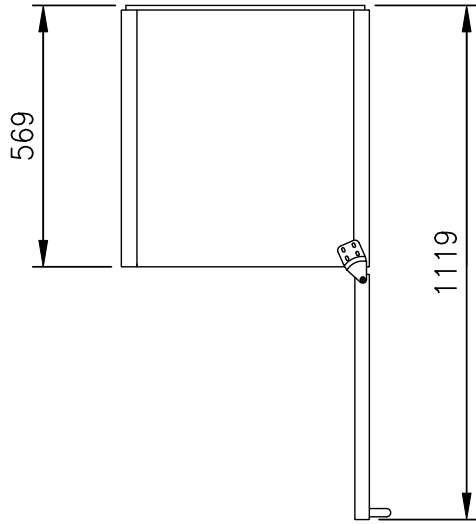

FCT-17RG

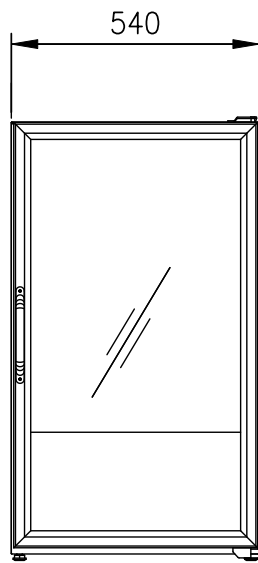

FCT-17RS / FCT-17SW

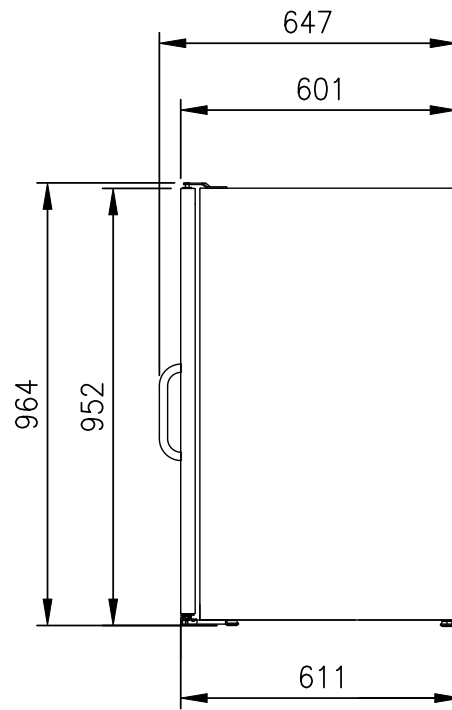

BAR EQUIPMENT

Model	Capacity (ℓ)	Exterior Dimension (mm)			Net Weight (kg)	Amps	Power Supply	Watt	HP	Refrigerant	No. Door
		W	D	H							
FCT-17RS/RG	170	540	647	964	58	1.5	10A	320	1/5	R-134a	1





5

DISPLAY CASE

Open Display Multideck

OPEN DISPLAY MULTIDECK



FOD-36VS

FOD-48VS

FOD-60VS

FOD-72VS

DISPLAY CASE

GLASS SIDE MODEL



FOD-36VG

FOD-48VG

FOD-60VG

FOD-72VG

FEATURES

- LED lights for each shelves
- Transparent night curtain for energy efficiency
- Angle adjustable shelves
- LED sign panel
- 4" casters
- Digital temperature display

TEMPERATURE

- 0°C ~ 5°C

OPTIONAL MODELS

- Remote model
- Electronic control with exterior digital display
- Leg levelers

PLAN VIEWS & SPECIFICATIONS

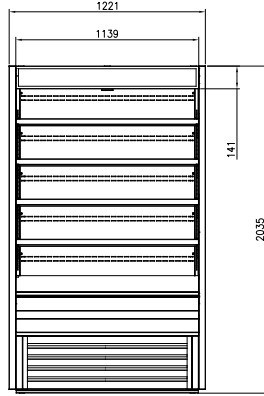
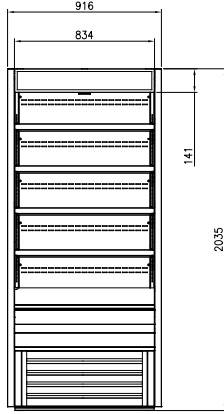
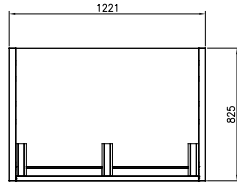
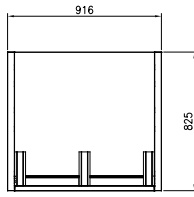

SIDE PLAN

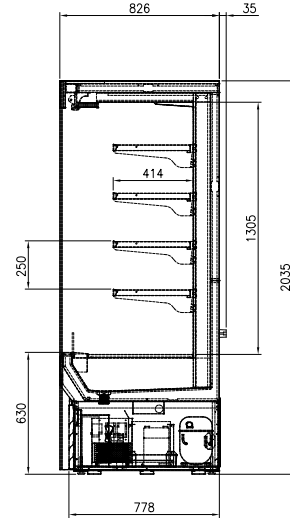

FOD-36VS / FOD-36VG

FOD-36VS / FOD-48VG

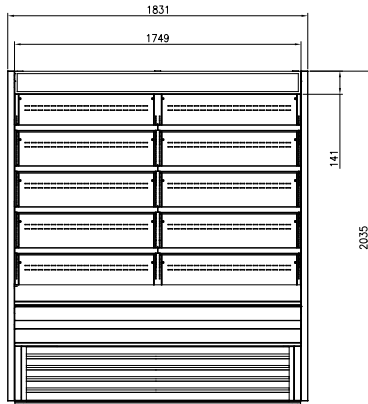
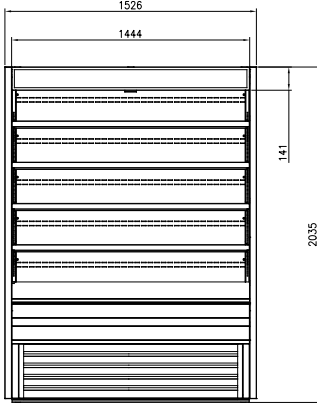
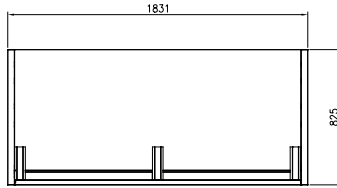

GLASS SIDE MODEL

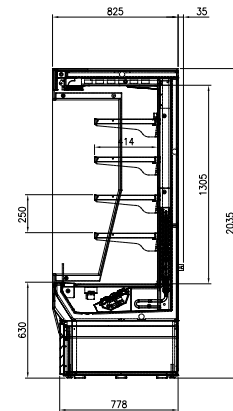

FOD-36VS / FOD-60VG

FOD-36VS / FOD-72VG

DISPLAY CASE

The height includes 4" caster (126mm)

Model	Capacity (l)	Exterior Dimension (mm)			Net Weight (kg)	Gross Weight (kg)	Amps	Power Supply	Watt	HP	Refrigerant	No. Shelf	No. Night Curtain
		W	D	H									
FOD-36VS	554	916	826	2,161	198	214	8.5	15A	1750	1	R-404A	4	1
FOD-48VS	756	1,221	826	2,161	238	254	8.5	15A	1750	1	R-404A	4	1
FOD-60VS	959	1,526	826	2,161	268	287	8.5	15A	1850	1	R-404A	4	1
FOD-72VS	1,162	1,831	826	2,161	337	359	9.5	30A	3500	1 × 2	R-404A	8	2
FOD-36VG	554	916	825	2,161	219	235	8.5	15A	1750	1	R-404A	4	1
FOD-48VG	756	1,221	825	2,161	258	274	8.5	15A	2030	1	R-404A	4	1
FOD-60VG	959	1,526	825	2,161	289	308	8.5	15A	1850	1	R-404A	4	1
FOD-72VG	1,162	1,831	825	2,161	356	379	9.5	30A	3500	1 × 2	R-404A	8	2

BAKERY CASE



FGR-09S



FGR-12S

DISPLAY CASE



FGR-15S



FGR-18S

FETURES

- Self contained system, no plumbing require
- Electronic temperature control
- Double pane glasses
- Water evaporatingsyste
- Stainless steel deck and air flow grille
- Straight, tempered front & side glass
- Minimal frame design for product display and visibility

TEMPERATURE

- 0°C ~ 5°C

OPTIONAL MODELS

- Caster model available

PLAN VIEWS & SPECIFICATIONS

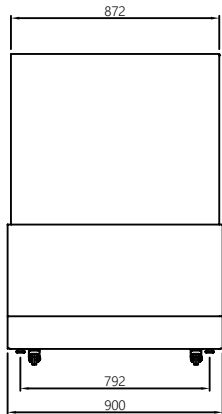
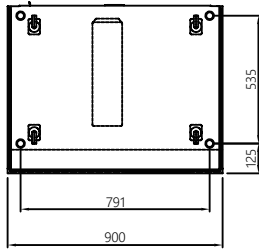

FGR-09S

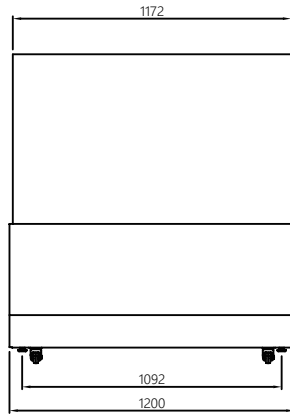
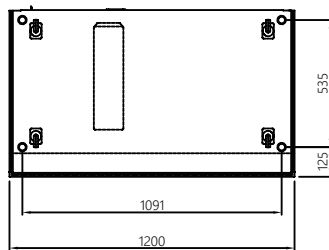

FGR-12S

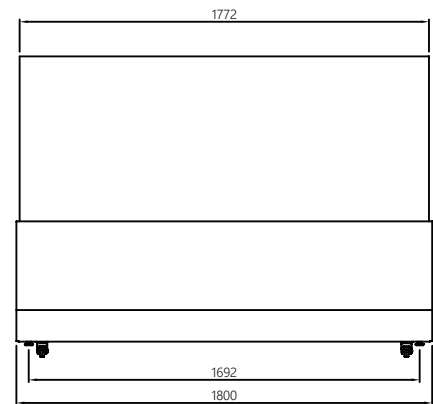
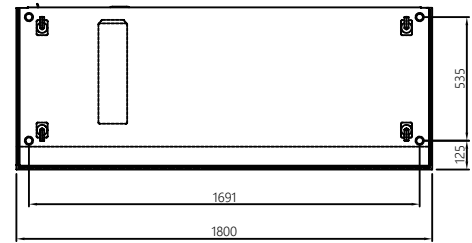

FGR-15S

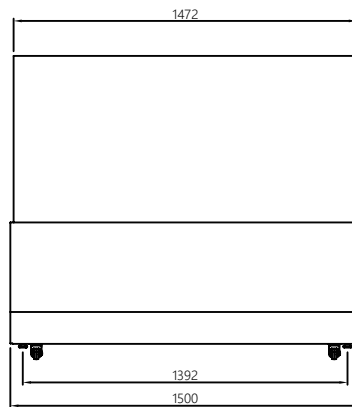
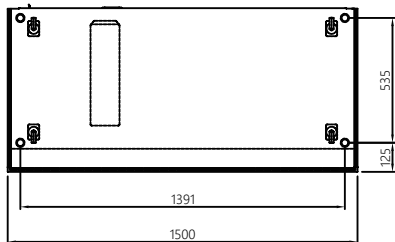

FGR-18S

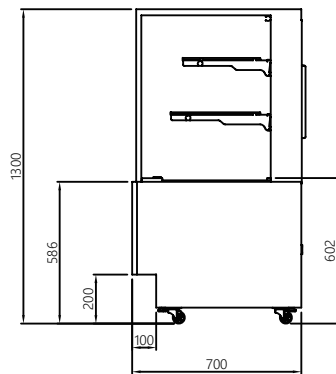

DISPLAY CASE

* Exterior dimensions include 3" Leg height

Model	Capacity (ℓ)	Exterior Dimension (mm)			Net Weight (kg)	Amps	Power Supply	Watt	HP	Refrigerant	Shelf
		W	D	H							
FGR-09S	298	900	700	1300	170	4.3	10A	445	3/8	R-134a	1 deck +2 shelves
FGR-12S	405	1200	700	1300	201	4.3	10A	445	3/8	R-134a	
FGR-15S	511	1500	700	1300	228	4.3	10A	445	3/8	R-134a	
FGR-18S	618	1800	700	1300	257	6.5	10A	1330	3/4	R-404A	

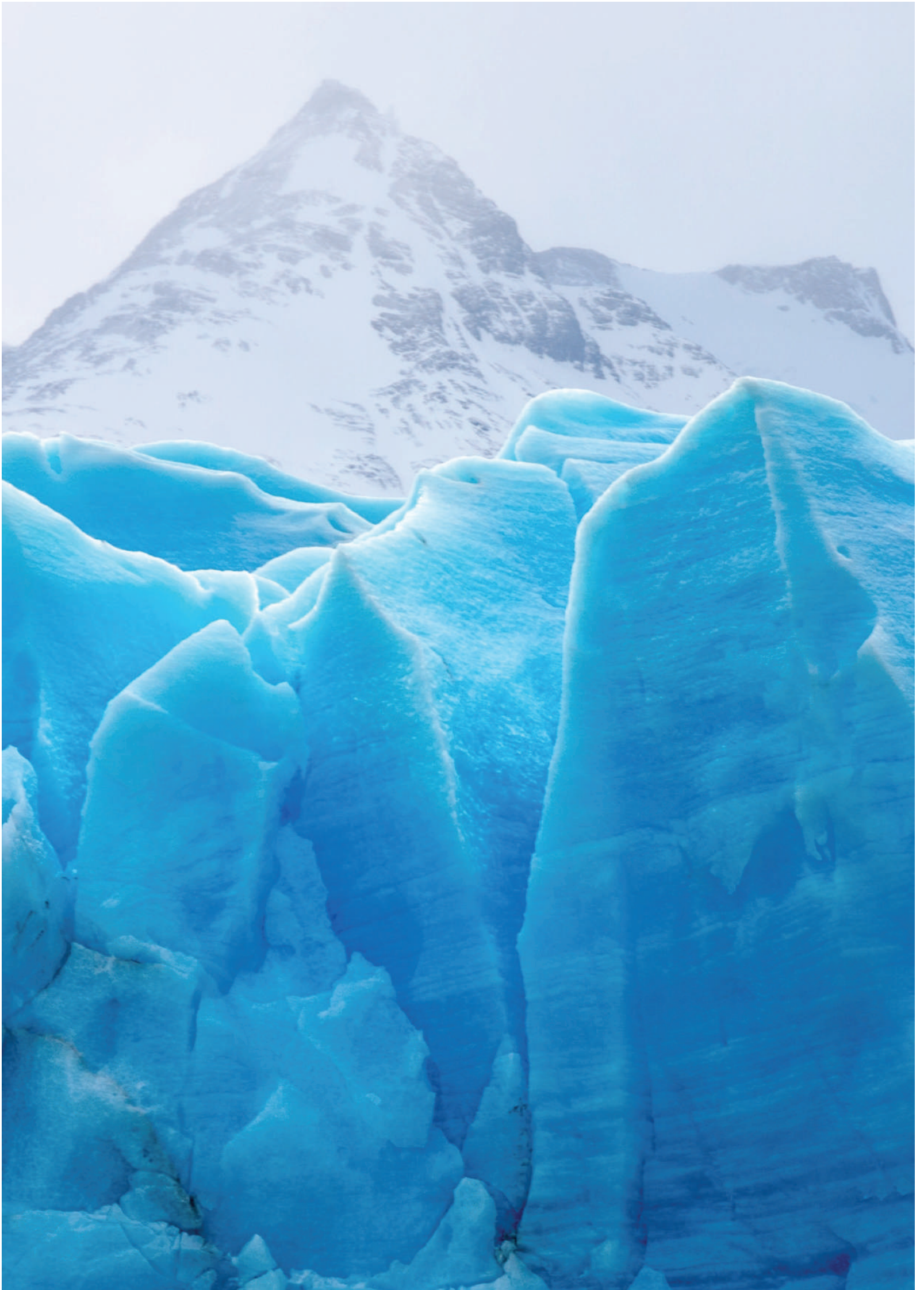



6

BLAST FREEZER

Blast Freezer

BLAST FREEZER



FBF-5



FBF-8



FBF-12

BLAST FREEZER

FEATURES

- Stainless steel finished top, front, sides and doors
- Stainless steel finished Interior

PAN SIZE

- 1) GN PAN: 20,8 x 12,8 in (530 x 325mm)
 - 2) EN PAN: 23,6 x 15,75 in (600 x 400mm)
 - 3) BUN PAN: 26 x 18 in (660 x 457mm)
 - 4) FULL PAN: 20 x 12 in (508 x 305mm)
- * pans are NOT included

CYCLE

CHILLING CYCLES

- Soft cycle (standard) - 90 mins
- Hard cycle (intensive) - 90 mins

FREEZING CYCLES

- Soft cycle (standard) - 240 mins
- Hard cycle (intensive) - 240 mins

TEMPERATURE

- Soft chilling: 90°C to 3°C within 90 mins (Max Temp: 0°C)
- Hard chilling: 90°C to 3°C within 90 mins (Max Temp: -20°C)
- Freezing: 90°C to -18°C within 240 mins (Max Temp: -40°C)

PLAN VIEWS & SPECIFICATIONS

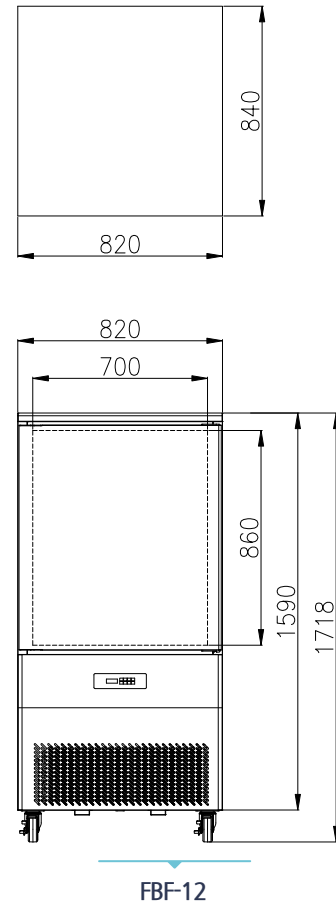
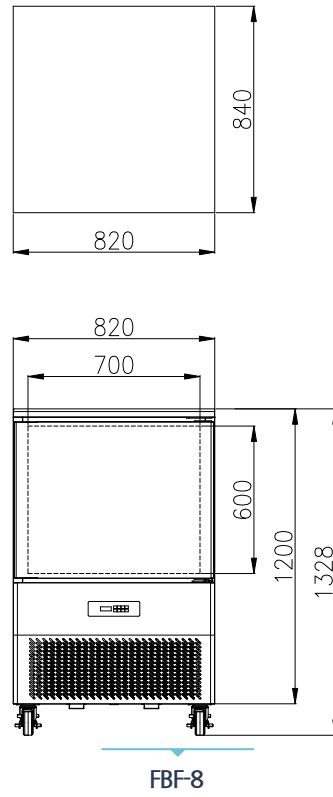
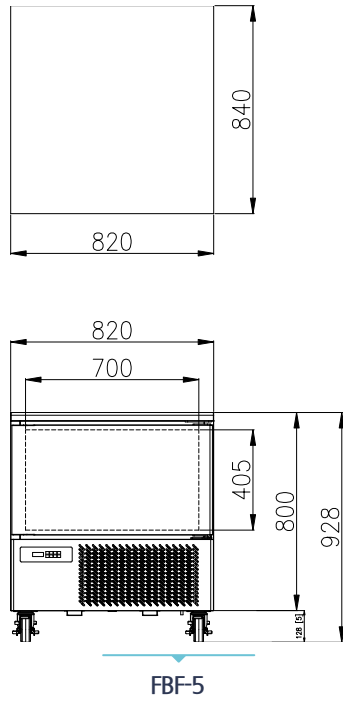

SIDE PLAN

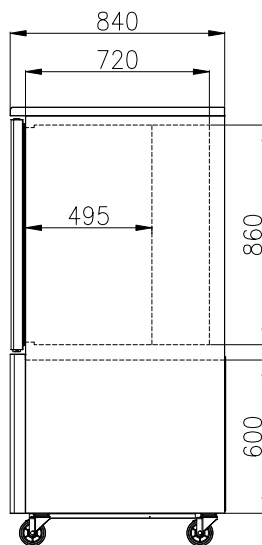

BLAST FREEZER

Model	Capacity (l)	Exterior Dimension (mm)			Interior Dimension (mm)			Net Weight (kg)	Amps	Voltage (V/Hz/Ø)	HP	Refrigerant	No. pan
		W	D	H	W	D	H						
FBF-5	140	820	840	928	700	485	405	110	5.2	220~240/50, 60/1	1	R-404A	5
FBF-8	208	820	840	1328	700	485	600	138	8.7	200~240/50, 60/1	1 1/2	R-404A	8
FBF-12	298	820	840	1718	700	485	860	166	8.7	220~240/50, 60/1	1 1/2	R-404A	12

