

# BOTTOM MOUNT REACH-IN REFRIGERATORS

## Bottom Mounted Condensing Unit

### EB – Series



▲ EBR68-1



▲ EBR74-1



▲ EBR74-2



▲ EBR100-2



▲ EBR126-2



▲ EBR137-2



▲ EBR190-3

#### Cabinet Construction

- Heavy duty stainless steel interior / exterior with rounded corners for a hazard-free workspace.
- Galvanized steel top, bottom and rear.
- 2.5" thick high density polyurethane insulation.
- Deeper cabinet interior for more storage options.
- Four 5" swivel casters with locks on front set Leg stabilizers standard for all models.

#### Refrigeration System

- Bottom mounted, self-contained and fully detachable Blizzard R290 condensing unit uses environmentally friendly, EPA-compliant R290 refrigerant with zero (0) Ozone Depletion Potential (ODP) and three (3) Global Warming Potential (GWP). Blizzard R290 is easily replaceable and requires no on-site brazing.
- Electronically commutated (ECM) fan motors achieve rapid cooling with less energy consumption.
- Full-length air duct system and airflow guard ensure optimal circulation of cold air.
- Time-initiated and temperature-terminated auto defrost cycle for seamless operation.
- Large capacity, corrosion-resistant condenser and evaporator coils.
- Self-maintaining, energy-efficient condensate drain pan requires no external drains or electric heaters.
- High performance, auto-reverse condenser fan motor supports compressor ventilation and condenser coil cleaning. Refer to owner's manual for full maintenance instructions.
- Pressure relief devices allow smooth access to cabinet interior when re-opening doors.
- Pre-wired and ready to plug, 240V/50Hz/1Ph, 10Amp Australian Plug

#### Lighting

- Energy efficient silicone coated and shatter-proof LED lighting provides bright, high color illumination with low heat output.

#### Doors

- Heavy duty stainless steel interior / exterior.
- 2.5" thick high density polyurethane insulation.
- Frame heaters prevent exterior moisture build up.
- Self-closing with adjustable torsion system for a positive seal.
- Snap-in magnetic door gasket make cleaning and replacement an easy process.
- High strength, recessed door handles.
- Pre-installed door locks keep your items safe from theft.
- Field reversible.

#### Shelving

- Three epoxy coated, steel wire shelves per section.
- Height adjustable stainless steel clips.

#### Temperature Control

- Multi-function digital controller with easy to read LED display.
- Factory preset temperature, 2°C
- Audible overheat protection alarm for compressor and condenser coil.

#### Options

- Additional shelving.
- 3" swivel casters with locks.
- 3.5" – 6" height-adjustable and interchangeable legs.
- Left hinged door.



**5 YEAR** Compressor  
**3 YEAR** Parts & Labor

## Dimensions

### ABS Legs



Two additional front adjustable stainless steel clad ABS legs to provide extra stability when opening and closing door.

### Vacuum Relief Mechanism



The vacuum relief valve equalizes cabinet pressure for rapid door re-entry.



Equipped with 10Amp Australian Plug

### Side View

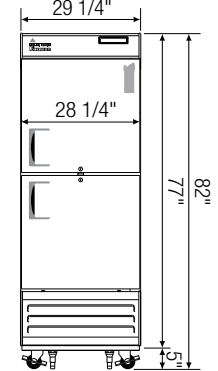
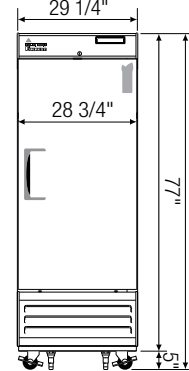
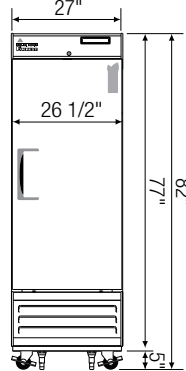
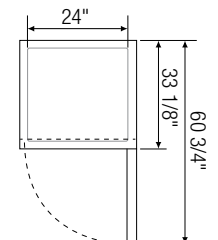
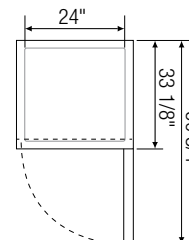
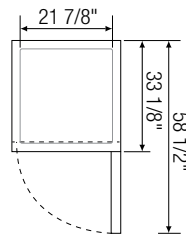
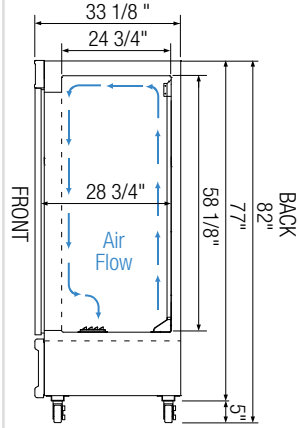

▲ EBR68-1

▲ EBR74-1

▲ EBR74-2

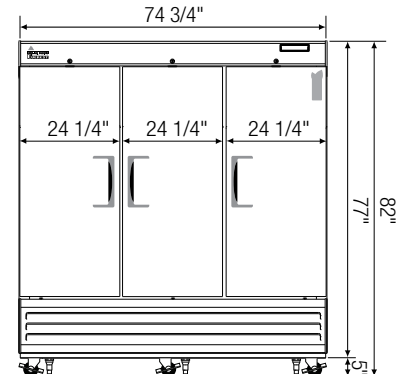
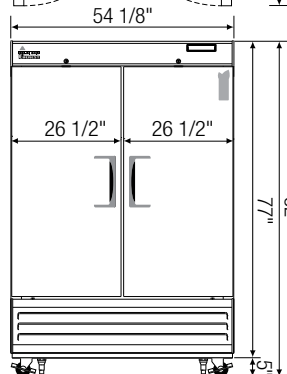
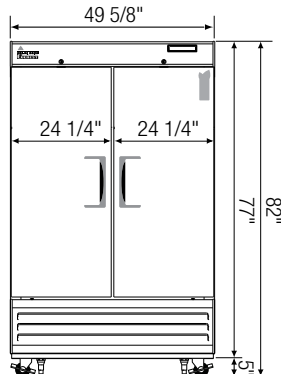
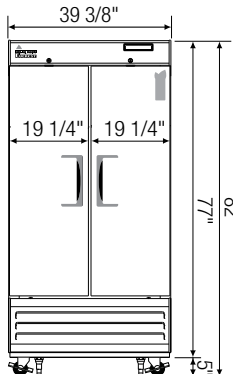
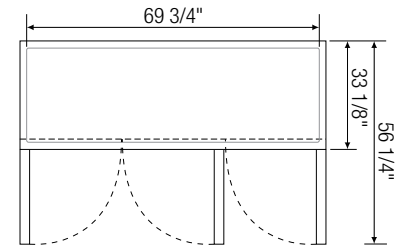
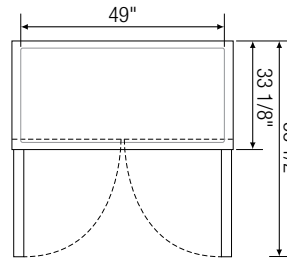
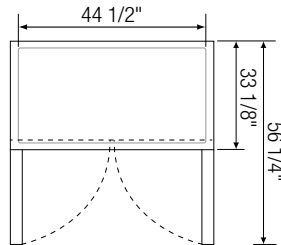
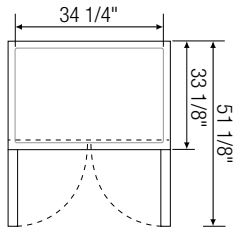

▲ EBR100-2

▲ EBR126-2

▲ EBR137-2

▲ EBR190-3

Model	Ref/ Frz/ Dual	# of Doors	Capacity (Cu. Ft.)	HP	BTU/HR <sup>†</sup>	Refrigerant	# of Shelves	Power (V-Hz-Ph)	Amps	Crated Weight (LBS)	Exterior Dimensions (Inches)		
											L	D	H*
EBR68-1	Ref	1	21	1/4+	1,852	R290	3	240-50-1	2.5	336	27	33 1/8	77
EBR74-1	Ref	1	23	1/4+	1,852	R290	3	240-50-1	2.5	341	29 1/4	33 1/8	77
EBR74-2	Ref	2 (H)	23	1/4+	1,852	R290	3	240-50-1	2.5	348	29 1/4	33 1/8	77
EBR100-2	Ref	2	33	1/3	2,311	R290	6	240-50-1	3	418	39 3/8	33 1/8	77
EBR126-2	Ref	2	48	1/3	2,311	R290	6	240-50-1	3.5	471	49 5/8	33 1/8	77
EBR137-2	Ref	2	50	1/3	2,311	R290	6	240-50-1	3.5	520	54 1/8	33 1/8	77
EBR190-3	Ref	3	71	3/4	4,445	R290	9	240-50-1	7	611	74 3/4	33 1/8	77

\*: Height does not include 5" for casters.

†: Based on evaporating temperature of 23°F (-5°C) & condensing temperature of 131°F (55°C).

Ref = Refrigerator | (H) = Half Door

Specifications subject to change without notice.

Product dimensions are for general purposes and not absolute value. Product capacity (▲) is calculated based on standard industry figures. Slight variations may exist. If dimensions and capacity are critical, please contact Austune Refrigeration. Blizzard R290 replacement is at the sole discretion of Everest Refrigeration.



Please visit our website for updated Energy Efficiency information.