

UNDERBENCH DRAWER

FT-1200F-D4

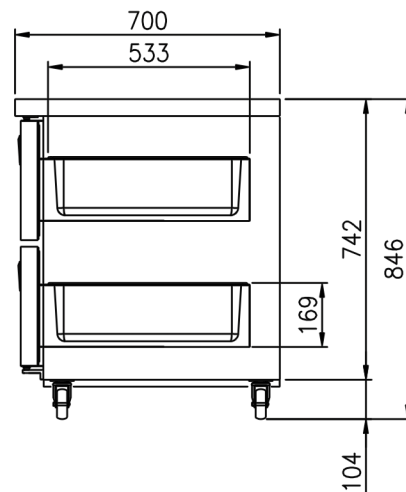
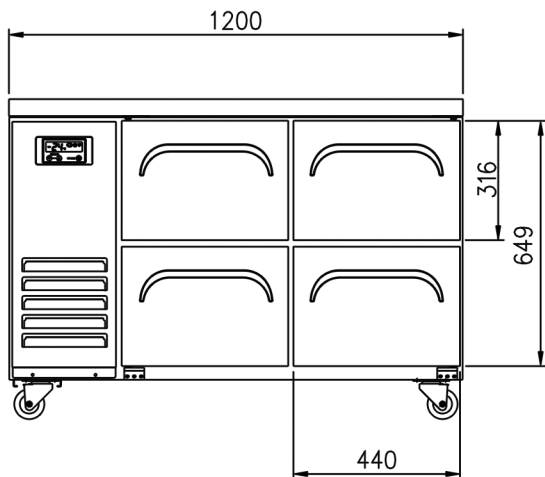
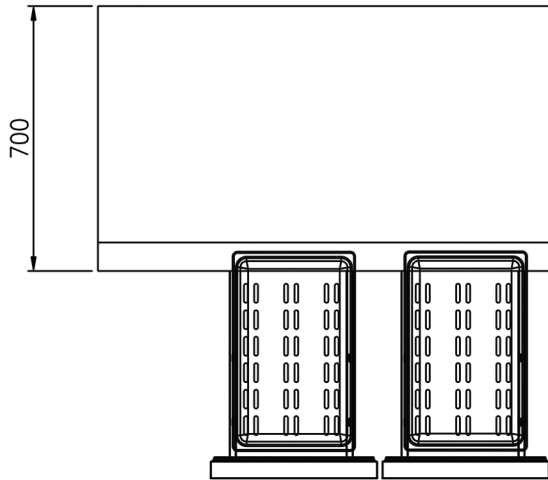

FEATURES

- Telescoping drawer slide
- Drawer can hold up to 40kg
- Accommodates full-size pan up to 15cm depth
- * Food pans are NOT included
- Digital temperature control & monitor system
- 3" casters (brakes at front)
- Fully stainless steel finished cabinet

TEMPERATURE

- Freezer: -18°C

OPTIONAL MODELS

- Leg model
- 4" or 5" casters

Model	Capacity (ℓ)	Exterior Dimension (mm)			Net Weight (kg)	Gross Weight (kg)	Power Supply	Amps	Voltage (V/Hz/Ø)	Watt	HP	Refrigerant	No. Drawer
		W	D	H									
FT-1200F-D4	293	1,200	700	846	78	86	10A	2.0	240/50/1	340	1/3	R-134a	4

* The heights include the caster (104mm) * D: Defrost

* Design and specifications subject to change without notice

* Actual shipping weight may differ due to extra packing materials for product protection.