

# UNDERBENCH DRAWER

## FT-1800R-D4 (SDD)

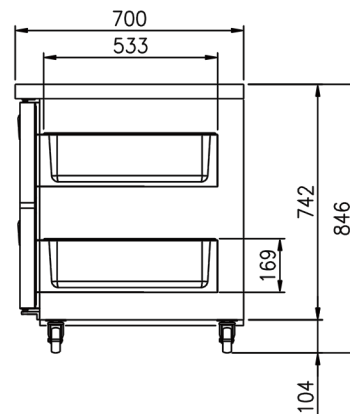
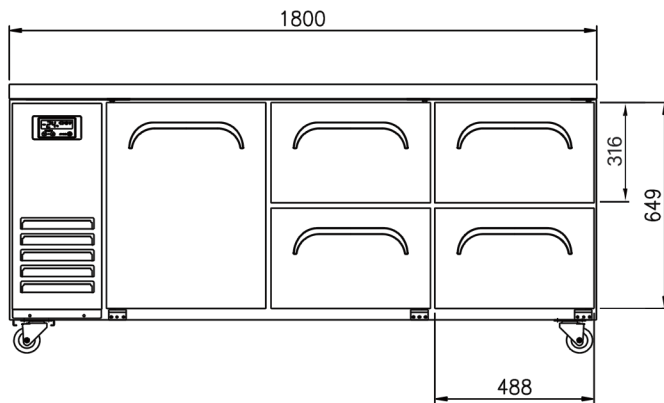
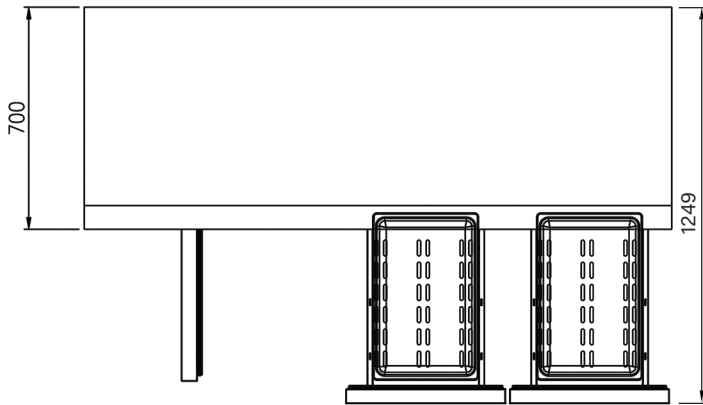

### FEATURES

- Telescoping drawer slide
- Drawer can hold up to 40kg
- Accommodates full-size pan up to 15cm depth
- \* Food pans are NOT included

- Digital temperature control & monitor system
- 3" casters (brakes at front)
- Fully stainless steel finished cabinet

### TEMPERATURE

- Fridge: 0°C ~ 5°C
- Freezer: -18°C

### OPTIONAL MODELS

- Leg model
- 4" or 5" casters

Model	Capacity (ℓ)	Exterior Dimension (mm)			Net Weight (kg)	Gross Weight (kg)	Power Supply	Amps	Voltage (V/Hz/Ø)	Watt	HP	Refrigerant	No. Drawer	No. Doors
		W	D	H										
FT-1800R-D4	509	1,800	700	846	95	108	10A	2.0	240/50/1	340	1/3	R-134a	4	1

\* The heights include the caster (104mm)

\* Design and specifications subject to change without notice

\* Actual shipping weight may differ due to extra packing materials for product protection.