

## FDU-18-SDD

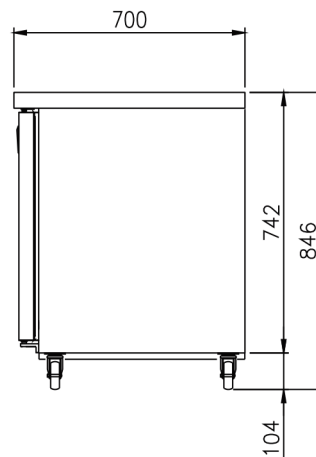
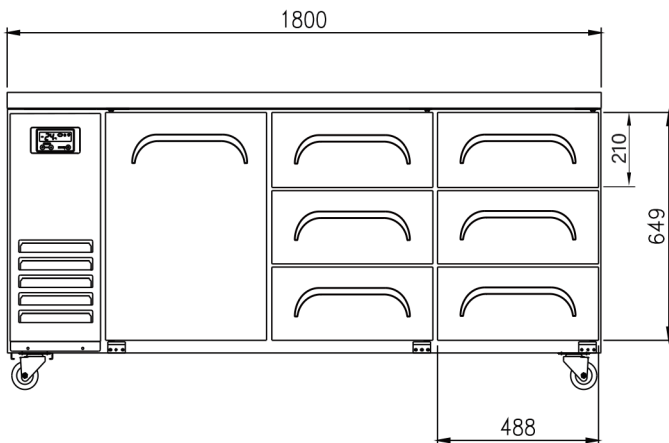
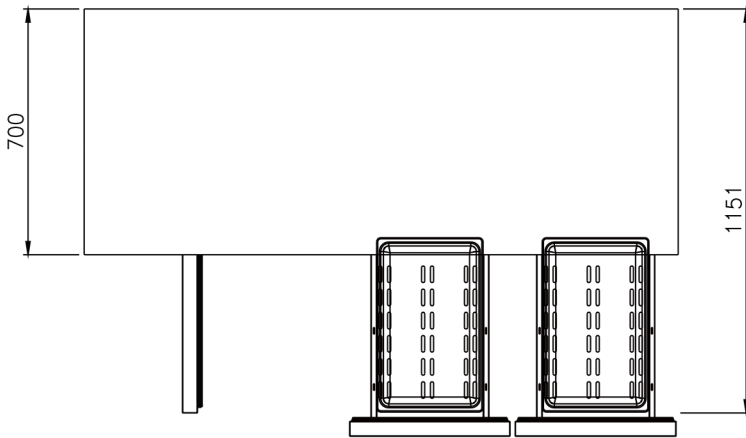

### FEATURES

- Digital temperature control & monitor system
- 3" casters (brakes at front)
- Fully stainless steel finished cabinet
- PE coated sturdy wire shelves
- Auto-closing doors & stopper
- Door pressure release device
- Magnetic door gasket

### TEMPERATURE

- Fridge: 0°C ~ 5°C
- Freezer: -18°C

### OPTIONAL MODELS

- Leg model
- 4" or 5" casters

Model	Capacity (ℓ)	Exterior Dimension (mm)			Net Weight (kg)	Gross Weight (kg)	Power Supply	Amps	Voltage (V/Hz/Ø)	Watt	HP	Refrigerant	No. Doors	No. Pans (1/1")	No. Drawer
		W	D	H											
FDU-1800	489	1,800	700	845	140	153	10A	2.0	240/50/1	340	1/3	R-134a	1	6	6

\* The heights include the caster (104mm) \* D: Defrost

\* Design and specifications subject to change without notice

\* Actual shipping weight may differ due to extra packing materials for product protection.