

UPRIGHT REACH-IN FREEZERS

Top Mounted Condensing Unit

EF - SERIES



▲ EF74-1



▲ EF74-2



▲ EF126-2



▲ EF150-2



▲ EF190-3

Cabinet Construction

- Heavy duty stainless steel interior / exterior with rounded corners for a hazard-free workspace.
- Galvanized steel top, bottom and rear.
- 2.5" thick high density polyurethane insulation.
- Four 5" swivel casters with locks on front set.

Refrigeration System

- Top mounted, self-contained and fully detachable condensing unit uses environmentally friendly R404A* refrigerant with zero (0) Ozone Depletion Potential (ODP) and EPA compliant R290 refrigerant with zero (0) Ozone Depletion Potential (ODP) and three (3) Global Warming Potential (GWP). R290 condensing units are replaceable and require no on-site brazing. *Ask about alternative refrigerant.
- PSC evaporator fan motors for R404A models. Electronically commutated (ECM) fan motors for R290 models.
- Airflow guard ensures optimal circulation of cold air. R290 models include full-length air duct system.
- Time-initiated and temperature-terminated auto defrost heater.
- Large capacity, corrosion-resistant condenser and evaporator coils.
- Self-maintaining, energy-efficient condensate drain pan requires no external drains or electric heaters.
- High performance condenser fan motors ensure efficient compressor ventilation. R290 models use auto-reverse condenser fan motors which also support condenser coil cleaning. Refer to owner's manual for full maintenance instructions.
- Pressure relief devices allow smooth access to cabinet interior when re-opening doors.
- Pre-wired and ready to plug, 240V/50Hz/1Ph.

Lighting

- Energy efficient silicone coated and shatter-proof LED lighting provides bright, high color illumination with low heat output.

Doors

- Heavy duty stainless steel interior / exterior.
- 2.5" thick high density polyurethane insulation.
- Frame heaters prevent exterior moisture build up.
- Self-closing with adjustable torsion system for a positive seal.
- Snap-in magnetic door gasket make cleaning and replacement an easy process.
- High strength, recessed door handles.
- Pre-installed door locks keep your items safe from theft.
- Field reversible.

Shelving

- Three epoxy coated, steel wire shelves per section.
- Height adjustable stainless steel clips.

Temperature Control

- Multi-function digital controller with easy to read LED display.
- Factory preset temperature, -20°C
- R290 models include audible overheat protection alarm for compressor and condenser coil.

Options

- Additional shelving.
- 3" swivel casters with locks.
- 3.5" – 6" height-adjustable and interchangeable legs.
- Left hinged door.

Dimensions

ABS Legs



Two additional front adjustable stainless steel clad ABS legs for model EF74-1 and EF126-2 to provide extra stability when opening and closing doors, and one additional leg for EF190-3 for weight support.

Equipped with Australian 10amp plug for all models

Side View

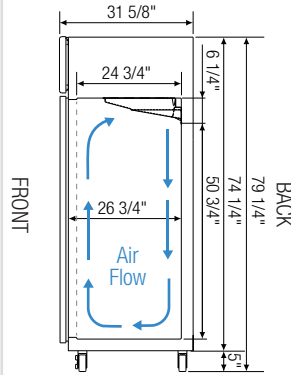

R404A models

Side View

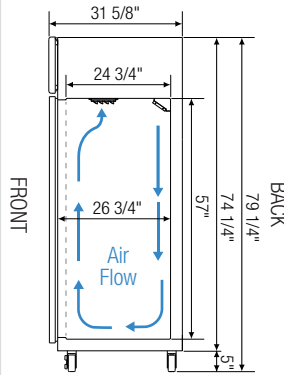

R290 models

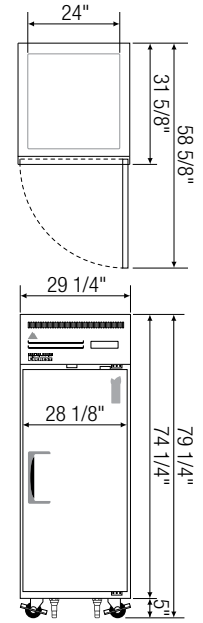

▲ EF74-1

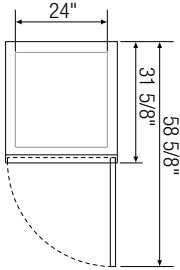

▲ EF74-2

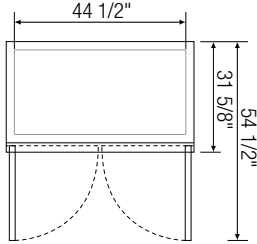

▲ EF126-2

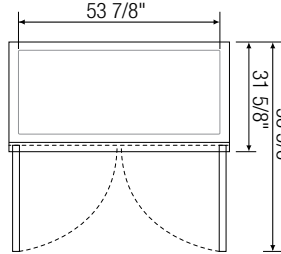

▲ EF150-2

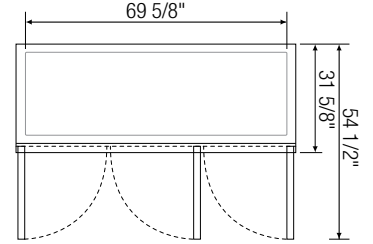

▲ EF190-3

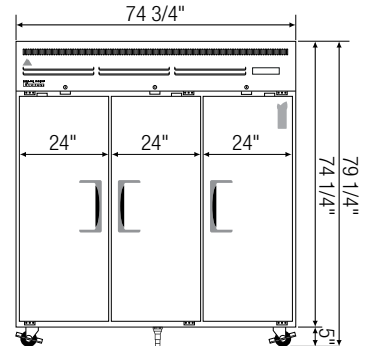
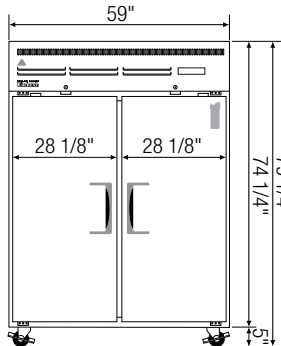
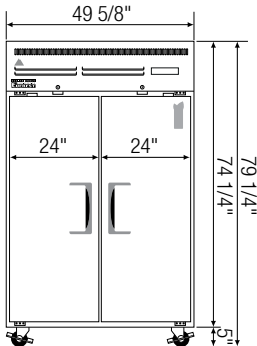
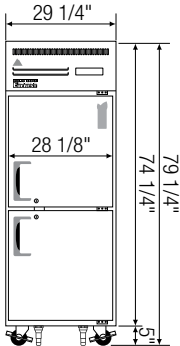

Model	Ref/ Frz/ Dual	# of Doors	Capacity (Litres)	HP	BTU/HR	Refrigerant	# of Shelves	Power	Crated Weight (KG)	Exterior Dimensions (Inches)		
										L	D	H*
EF74-1	Frz	1	557	1/2	1,670	R290	3	240-50-1	144	740	803	1910
EF74-2	Frz	2 (H)	557	1/2	1,670	R290	3	240-50-1	146	740	803	1910
EF126-2	Frz	2	1032	1/2 x 2	3,435 x 2	R-404A/R290 [^]	6	240-50-1	212	1260	803	1910
EF150-2	Frz	2	1251	1/2 x 2	3,435 x 2	R-404A/R290 [^]	6	240-50-1	229	1500	803	1910
EF190-3	Frz	3	1616	1/2 x 2	3,435 x 2	R-404A/R290 [^]	9	240-50-1	299	1900	803	1910

* : Height does not include 5" for casters.

Frz = Freezer | (H) = Half Door

† : Based on evaporating temperature of 23°F (-5°C) & condensing temperature of 131°F (55°C).

[^] : Contact factory for R290 information.

Specifications subject to change without notice.

Product dimensions are for general purposes and not absolute value. Product capacity (▶) is calculated based on standard industry figures. Slight variations may exist. If dimensions and capacity are critical, please contact Austune Refrigeration.

Blizzard R290 replacement is at the sole discretion of Everest Refrigeration.



Please visit our website for more information.
<http://www.austunecommercial.com/>