

UNDERBENCH DRAWER

FT-900R-D2 | FT-900F-D2

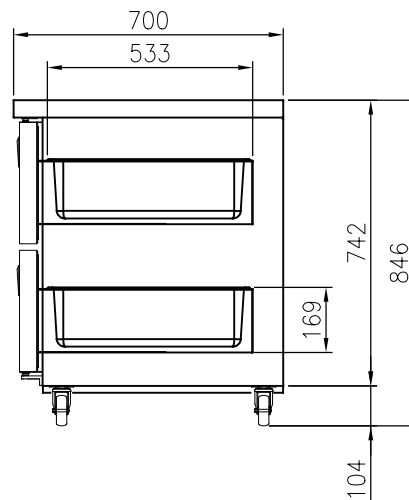
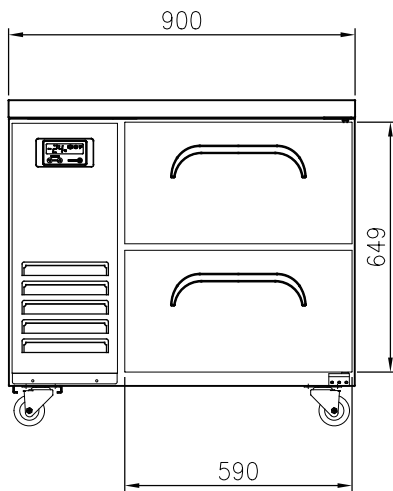
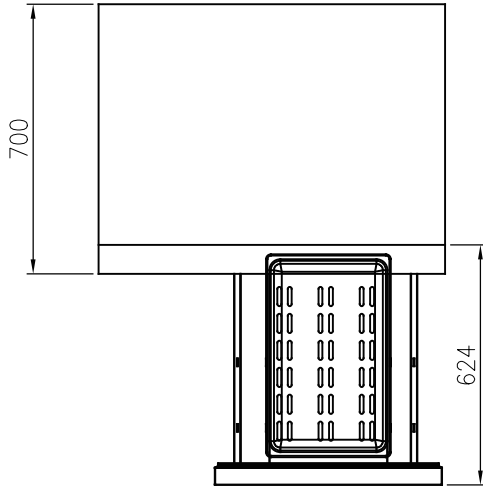

FEATURES

- Telescoping drawer slide
- Drawer can hold up to 40kg
- Accommodates full-size pan up to 15cm depth
- * Food pans are NOT included

- Digital temperature control & monitor system
- 3" casters (brakes at front)
- Fully stainless steel finished cabinet

TEMPERATURE

- Fridge: 0°C ~ 5°C
- Freezer: -18°C

OPTIONAL MODELS

- Leg model
- 4" or 5" casters

Model	Capacity (ℓ)	Exterior Dimension (mm)			Net Weight (kg)	Gross Weight (kg)	Power Supply	Amps	Voltage (V/Hz/Ø)	Watt	HP	Refrigerant	No. Drawer
		W	D	H									
FT-900R-D2	186	900	700	846	61	66	10A	2.0	240/50/1	340	1/3	R-134a	2
FT-900F-D2	186	900	700	846	64	69	10A	3.0	240/50/1	380(D:520)	3/8	R-134a	2

* The heights include the caster (104mm) * D: Defrost
 * Design and specifications subject to change without notice
 * Actual shipping weight may differ due to extra packing materials for product protection.

UNDERBENCH DRAWER

FT-1200R-D4 | FT-1200F-D4

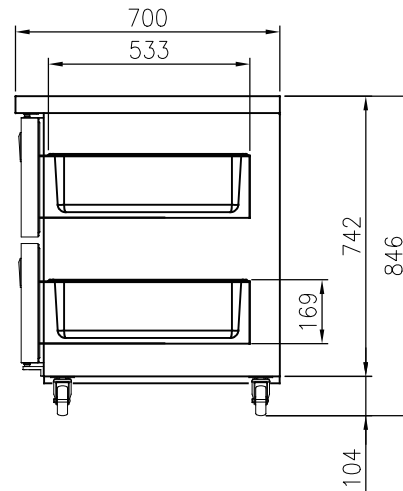
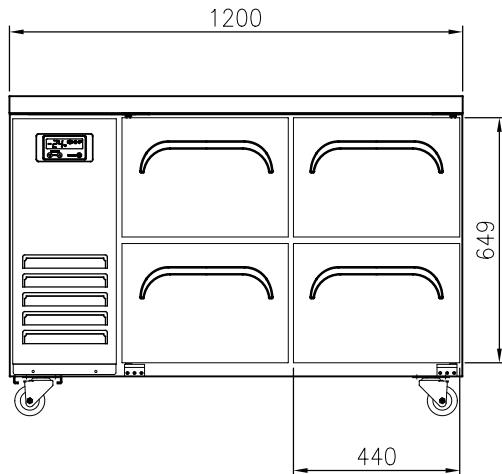
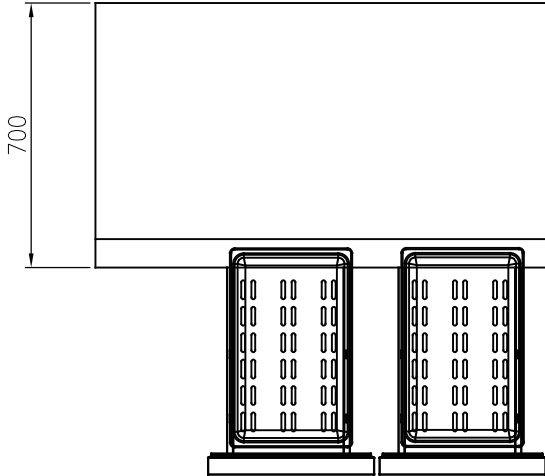

FEATURES

- Telescoping drawer slide
- Drawer can hold up to 40kg
- Accommodates full-size pan up to 15cm depth
- * Food pans are NOT included

- Digital temperature control & monitor system
- 3" casters (brakes at front)
- Fully stainless steel finished cabinet

TEMPERATURE

- Fridge: 0°C ~ 5°C
- Freezer: -18°C

OPTIONAL MODELS

- Leg model
- 4" or 5" casters

Model	Capacity (ℓ)	Exterior Dimension (mm)			Net Weight (kg)	Gross Weight (kg)	Power Supply	Amps	Voltage (V/Hz/Ø)	Watt	HP	Refrigerant	No. Drawer
		W	D	H									
FT-1200R-D4	293	1,200	700	846	78	86	10A	2.0	240/50/1	340	1/3	R-134a	4
FT-1200F-D4	293	1,200	700	846	81	89	10A	3.0	240/50/1	380(D:520)	3/8	R-134a	4

* The heights include the caster (104mm) * D: Defrost
 * Design and specifications subject to change without notice
 * Actual shipping weight may differ due to extra packing materials for product protection.

UNDERBENCH DRAWER

FT-1500R-D4 | FT-1500F-D4

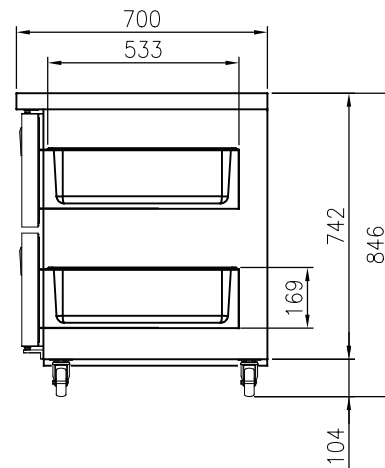
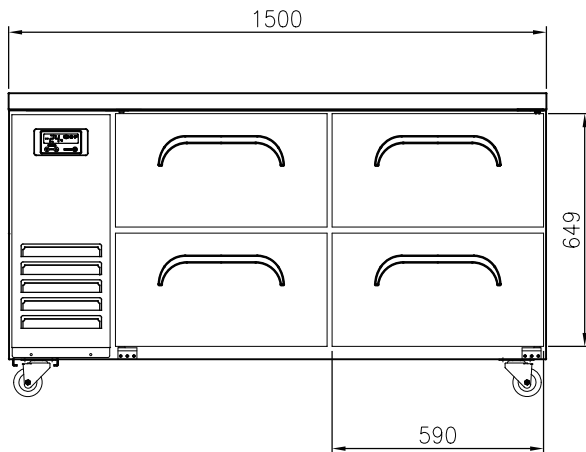
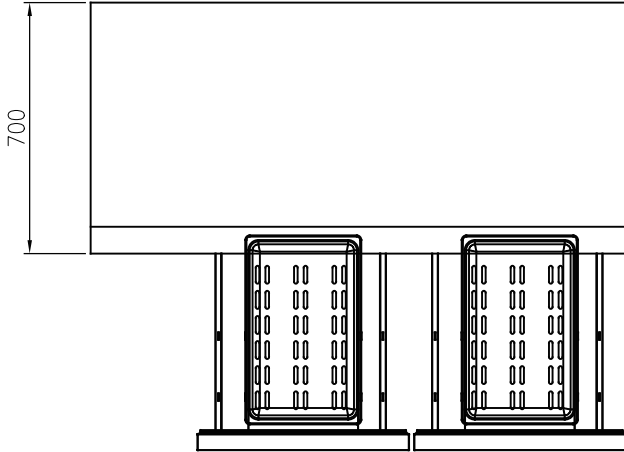

FEATURES

- Telescoping drawer slide
- Drawer can hold up to 40kg
- Accommodates full-size pan up to 15cm depth
- * Food pans are NOT included
- Digital temperature control & monitor system
- 3" casters (brakes at front)
- Fully stainless steel finished cabinet

TEMPERATURE

- Fridge: 0°C ~ 5°C
- Freezer: -18°C

OPTIONAL MODELS

- Leg model
- 4" or 5" casters

Model	Capacity (ℓ)	Exterior Dimension (mm)			Net Weight (kg)	Gross Weight (kg)	Power Supply	Amps	Voltage (V/Hz/Ø)	Watt	HP	Refrigerant	No. Drawer
		W	D	H									
FT-1500R-D4	402	1,500	700	846	84	94	10A	2.0	240/50/1	340	1/3	R-134a	4
FT-1500F-D4	342	1,500	700	846	87	97	10A	3.0	240/50/1	380(D:520)	3/8	R-134a	4

* The heights include the caster (104mm) * D: Defrost
 * Design and specifications subject to change without notice
 * Actual shipping weight may differ due to extra packing materials for product protection.

UNDERBENCH DRAWER

FT-1800R-D6

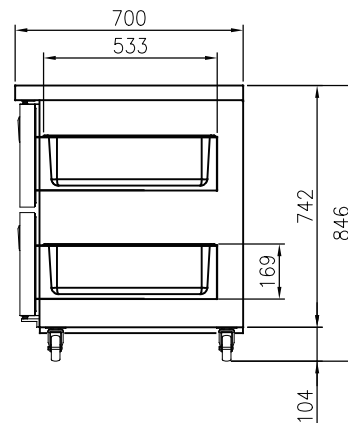
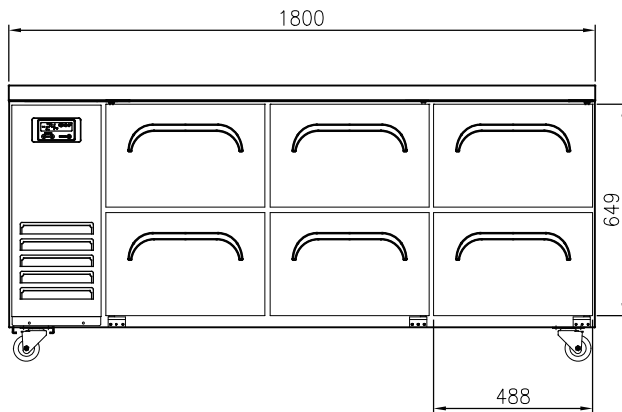
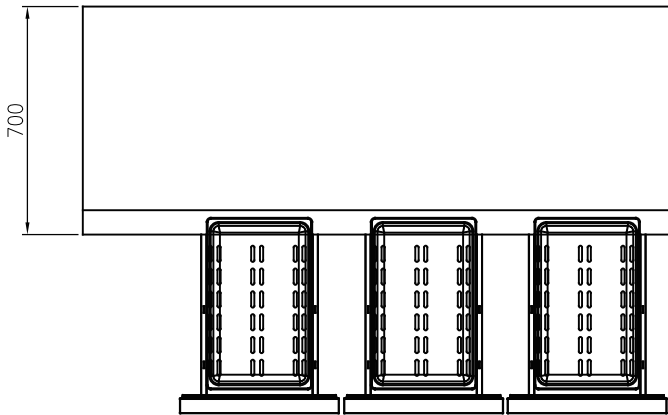

FEATURES

- Telescoping drawer slide
- Drawer can hold up to 40kg
- Accommodates full-size pan up to 15cm depth
- * Food pans are NOT included
- Digital temperature control & monitor system
- 3" casters (brakes at front)
- Fully stainless steel finished cabinet

TEMPERATURE

- Fridge: 0°C ~ 5°C
- Freezer: -18°C

OPTIONAL MODELS

- Leg model
- 4" or 5" casters

Model	Capacity (ℓ)	Exterior Dimension (mm)			Net Weight (kg)	Gross Weight (kg)	Power Supply	Amps	Voltage (V/Hz/Ø)	Watt	HP	Refrigerant	No. Drawer
		W	D	H									
FT-1800R-D6	509	1,800	700	846	95	108	10A	2.0	240/50/1	340	1/3	R-134a	6

* The heights include the caster (104mm)
 * Design and specifications subject to change without notice
 * Actual shipping weight may differ due to extra packing materials for product protection.