

Nodus Factory™

Textile fittings & connectors

Nodusfactory-Sail©

2024



www.nodusfactory.com

Créateur d'accastillage & solutions textiles



Innovate to rig, Noder!

Nodus Factory "Short circuit and proximity"!

Our Nodusfactory-Sail catalogue has been designed interactively to help you make the right choices.

Link : <https://www.nauticexpo.fr/prod/nodus-factory-66050.html>

You can scan the Qr code on each product sheet to place your order via our online shop.

Our technical advice call centre is also at your disposal.

Link : +33 (0) 2 97 67 64 83

In Europe, you are supported by our partners who benefit from all the expertise, sales support and personalized advice of the Nodus Factory Sail team.

Link: <https://www.nauticexpo.fr/prod/nodus-factory-66050.html>

With our export partners, we have set up local supply points to quickly satisfy your needs and desires.

Link: <https://www.nauticexpo.fr/prod/nodus-factory-66050.html>

Meeting your expectations in terms of high-performance textile fittings to equip you easily and more safely remains a constant in the research and development of our products.

Designed and manufactured in France, our products are tested and certified by Bureau Veritas, guaranteeing the conformity of our products.

Thank you for your trust.

Good navigation.

FAQ – A question ?



Nodus Factory™

Parc d'Activités de Laroiseau
5, rue Ella Maillart
F – 56000 Vannes

Tél : +33 (0) 2 97 67 64 83

Email : sail@nodusfactory.com

Textile Shackles®



Dyneema® shackles

Used for almost all manoeuvres, textile shackles are an essential equipment on board sailing boats.



Each shackle model has a specific use and comes in a range of sizes to suit your needs.

Your choice should be based on its use



Dyneema® Nodusfactory™ textile shackles have many advantages:

- lightweight
- mechanical strength
- UV resistance
- excellent abrasion resistance



Which rope for which use?

To ensure the best performance, durability and reliability from your lines, it's important to choose the right fabric!

Whether it's for your sheets, halyards or mooring lines, Nodus Factory™ has put together a comparative table of the different fibers.

Material	Resistance	Lengthening	Longevity	Use
Polyester	3	3	3	Polyvalent
Polyamide	2	1	2	Mooring lines
Polypropylène	2	1	1	Towing
High-modulus polyethylene	5	4	4	Running rigging and sheathing
Aramid	4	4	2	Standing rigging and sheathing
PBO	3	5	1	Standing rigging

Polyester's main quality is its longevity and UV resistance, but its weakness is its elongation (elasticity), which can vary between 8 and 12%, depending on the quality of the fiber. Our Nodus Factory™ halyards and sheets use 'high tenacity' polyesters, which have a lower elongation than standard quality polyester.

Polyamide has a higher elongation (15-20%), but its high elasticity makes it ideal for mooring, as the fibers protect the cleats from shocks by absorbing jolts. However, a conventional polyamide mooring line is heavy to handle and is not water-repellent, as it absorbs water. Dockline® Nodus Factory mooring lines are made from HT polyester for greater durability.

High modulus **polyethylene** or Dyneema® or Spectra®, have a similar elongation at break and a breaking strength greater than that of aramid fibers, or eight times that of stainless steel. The advantage of Dyneema® is that it is UV and abrasion resistant, making it ideal for sheaths. Its weakness is that under static load, when subjected to high and prolonged tension, the fiber elongates irreversibly (creep). However, the latest technological developments have made it possible to develop a particularly stable Dyneema®.

Aramids, marketed under the Name Kevlar® or Technora®, have high impact resistance and excellent breaking strength. The advantages of aramids fibers are low elongation at break (around 3.5%) and remarkable stability under static load (no creep), so the fiber is very strong (five times stronger than stainless steel), with very low elasticity. It is also highly resistant to friction (heat) at 450°C. However, aramids are not very UV-resistant.

PBO, a high-performance but fragile fiber, has a very limited lifespan because it cannot withstand UV rays or scratching, but its advantages are its exceptional breaking strength, very low elongation (elasticity) and excellent mechanical and thermal stability.

Application range - Connector on Dyneema® rope

T-close		Strope				
Sail m2	Rope	6 mm	8 mm	10 mm	12 mm	14 mm
Upwind		E T-close 3	E T-close 5	E T-close 6	E T-close 8	E T-close 8
	∅ Strope	3 mm	4 mm	5 mm	6 mm	7 mm
Wind Bft	Wind kts	m2	m2	m2	m2	m2
8 Bft	40	26	55	78	113	113
Downwind		E T-close 3	E T-close 5	E T-close 6	E T-close 8	E T-close 8
	∅ Strope	3 mm	4 mm	5 mm	6 mm	7 mm
Wind Bft	Wind kts	m2	m2	m2	m2	m2
8 Bft	40	41	86	122	175	175

T-bone		Strope				
Sail m2	Rope	6 mm	8 mm	10 mm	12 mm	14 mm
Upwind		E M6	E M8	E M10	E M12	E M14
	∅ Strope	3 mm	4 mm	5 mm	6 mm	7 mm
Wind Bft	Wind kts	m2	m2	m2	m2	m2
8 Bft	40	43	59	89	125	188
Downwind		E M6	E M8	E M10	E M12	E M14
	∅ Strope	3 mm	4 mm	5 mm	6 mm	7 mm
Wind Bft	Wind kts	m2	m2	m2	m2	m2
8 Bft	40	66	92	139	195	293

Spliced eye		Eye strope				
Sail m2	Rope	6 mm	8 mm	10 mm	12 mm	14 mm
Upwind		E eye 3	E eye 4	E eye 5	E eye 6	E eye 7
	∅ Strope	3 mm	4 mm	5 mm	6 mm	7 mm
Wind Bft	Wind kts	m2	m2	m2	m2	m2
8 Bft	40	54	99	154	214	324
Downwind		E eye 3	E eye 4	E eye 5	E eye 6	E eye 7
	∅ Strope	3 mm	4 mm	5 mm	6 mm	7 mm
Wind Bft	Wind kts	m2	m2	m2	m2	m2
8 Bft	40	85	154	239	333	504

T-sail		Strope		
Sail m2	Rope	4 mm	5 mm	6 mm
Upwind		E T-sail 5	E T-sail 6	E T-sail 7
Wind Bft	Wind kts	m2	m2	m2
8 Bft	40	27	47	74
Downwind		E T-sail 5	E T-sail 6	E T-sail 7
Wind Bft	Wind kts	m2	m2	m2
8 Bft	40	43	73	115

T-drop		Strope			
Sail m2	Rope	8 mm	10 mm	12 mm	14 mm
Upwind		E T-d 12	E T-d 12	E T-d 16	E T-d 16
Wind Bft	Wind kts	m2	m2	m2	Wind Bft
8 Bft	40	21	33	30	30
Downwind		E T-d 12	E T-d 12	E T-d 16	E T-d 16
Wind Bft	Wind kts	m2	m2	m2	Wind Bft
8 Bft	40	33	33	47	47

T-close K[®] - Adjustable textile shackle

« Universal adjustable textile connector »



Product Name	Breaking Load	Weight	Length Adjustable Loop	Sheave Pulley Ø	Sail area
	Direct		Mini/maxi		40 kts
	kg	gr	cm	mm	m2
K / Ks 2	380	2 / 4	1/7	15/30	10
K / Ks 3	750	4 / 8	2/9	30/40	21
K / Ks 5	1900	14 / 16	3/10	40/50	52
K / Ks 6	2600	26 / 28	4/12	50/60	71
K / Ks 8	4800	56 / 60	5/17	60/70	132

TECHNICAL SHEET

- T-close[®] connector ↪ Glass-filled Pa Tech
- 100% Dyneema[®] rope
- ✓ SK78 12 plaits
- ✓ pre-stretched, coated ↪ Light grey / black
- Dyneema[®] sheath for the Ks "Technical Range" model
- ✓ 48 plaits coated Black
- Accessories
- ✓ Block[®] ring ↪ flexible thermoplastic TPE

USE

- Universal adjustable Dyneema[®] textile connector, for pulleys, booms, sheets, halyards, sails, lazy-bag, etc.

How to change the length of the loop :

- Slide the T-close[®] connector, then close the loop with the Grip[®] Knot.



Information sail@nodusfactory.com

NODUS
FACTORY

MADE IN FRANCE

www.nodusfactory.com



Scan me !

T-close K[®] - Adjustable textile shackle

« "Universal adjustable textile connector" »



T-close K[®], universal, multi-purpose textile shackle in Dyneema[®] with adjustable loop.

- Can be used in a wide range of situations, making it the 'Swiss Army knife' for your boat.

Uses

Universal adjustable Dyneema[®] textile connector for blocks, booms, sheets, halyards, sails, lazy-bags, etc.

How to change the length of the loop :

- Slide the T-close connector, then lock with the Grip[®] Knot.

Advantages

- Adjustable and multi-purpose
- Secure "under load and off load" locking
- Easy to install and open, even under heavy load
- Highly UV-resistant and excellent abrasion resistance

References

Shackle K2	20001
Shackle K3	20002
Shackle K5	20003
Shackle K6	20004
Shackle K8	20005

Shackle K2 S	20190
Shackle K3 S	20191
Shackle K5 S	20192
Shackle K6 S	20193
Shackle K8 S	20194

Nodus Tips

- Used with the Block ring and a friction ring, you now have a friction pulley,
- ✓ Be careful to cross the strands when fitting the ring.
- ✓ Tutorial available on our YouTube channel

NODUS
FACTORY
MADE IN FRANCE

Parc d'Activités de Laroiseau • 5 rue Ella Maillart • F- 56000 Vannes
Tél : +33 (0)2 97 67 64 83 • Mail : sail@nodusfactory.com www.nodusfactory.com



Ms B[®] - Textile shackle with Dyneema[®] sheath

« "Dyneema[®] textile shackle »



Product Name	Breaking Load	Length	Sail Area
Shackle « Bosco »	Direct	Closed	40 kts
	Kg	cm	M2
Ms B	2 500	10	70

TECHNICAL SHEET

- Dyneema[®] SK78
- ✓ 48 plaits, coated for better protection and longevity of the textile fiber
- The length corresponds to the closed textile shackle
- The indicated load is the breaking load.
- Block[®] ring
- ✓ Clamping and retaining ring, made of flexible thermoplastic TPE, which enables a low-friction ring to be quickly locked and secured.

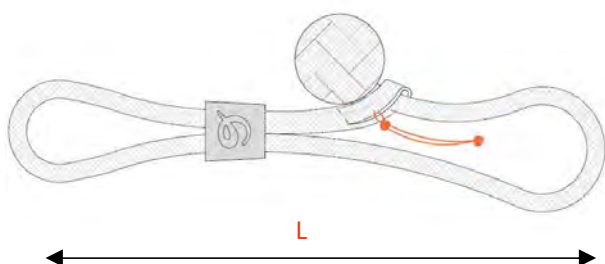

USE

- Textile Dyneema[®] shackle for connections between two elements: sheets, halyards, sails, mainsail tackles, hoists, etc.
- Easy to use ⇨ Pulling toggle
- Our Dyneema[®] sheathed textile shackles are designed for long-lasting use in the toughest conditions.

Information sail@nodusfactory.com

NODUS
FACTORY

MADE IN FRANCE

www.nodusfactory.com



Scan me !

Ms B[®] - Textile shackle with Dyneema[®] sheath

« "Dyneema[®] textile shackle »



Nodusfactory[®] manufactures this high-quality textile shackle in pre-stretched Dyneema[®] sheath.

- The ideal connector for fittings on your sailboat.
- More durable, lighter and more reliable than stainless steel carabiners or shackles.

Our textile shackles are made from a Dyneema[®] braid with a hot-enzymatic coating to give the fibers greater resistance to wear over time.

Advantages

- Very good abrasion resistance
- Opening pull and captive system - Block[®] Ring
- Several lengths available on request
- Bosco knot / Laminated knob loop

Technical information

- coated Dyneema[®] for better protection and longevity of the textile fiber
- The length corresponds to the closed textile shackle
- The indicated load is the breaking load.
- Block[®] Ring, clamping and retaining ring, made of flexible Thermoplastic TPE, which enables a low-friction ring to be clamped and secured quickly.

Reference

Shackle Ms-B	20213
--------------	-------

NODUS
FACTORY
MADE IN FRANCE

Parc d'Activités de Laroiseau • 5 rue Ella Maillart • F- 56000 Vannes
Tél : +33 (0)2 97 67 64 83 • Mail : sail@nodusfactory.com www.nodusfactory.com



Shackle C[®] - Halyard & Sheet

« Dyneema[®] fiber textile connector »

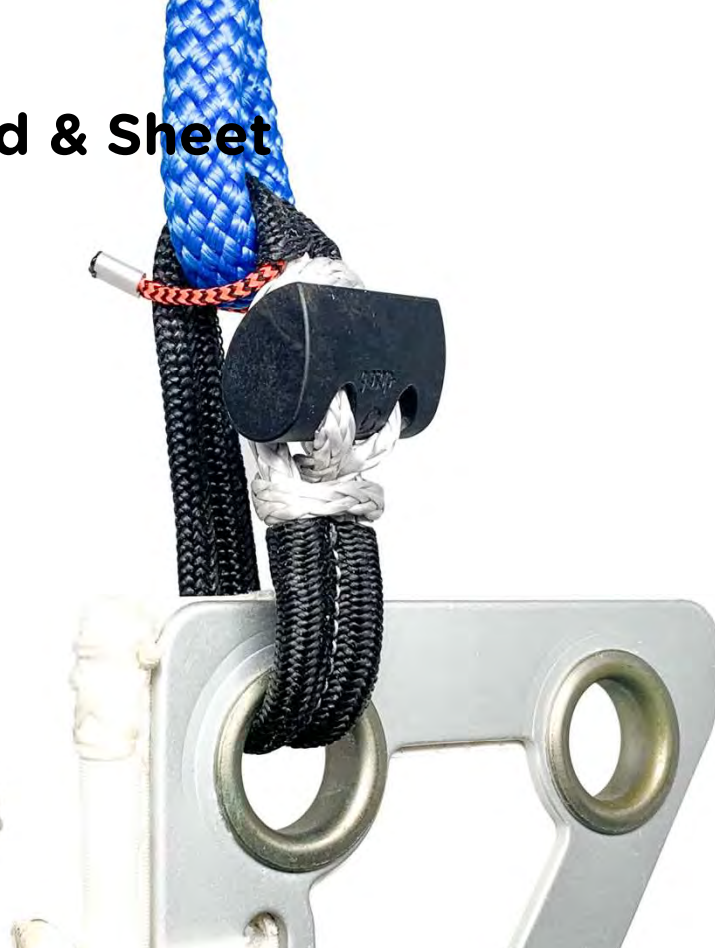

Product Name	Breaking load	Ø rope	Length	Weight	Sail area
Connector	Direct	Dyneema [®]	Close		40 kts
T-Close / PA Tech	Kg	mm	cm	gr	M2 > 45°
C 3	840	2,5	4	4 / 6	20 / 50
C 5	1800	4	7	12 / 14	50 / 70
C 6	2500	5	8	28 / 30	70 / 90
C 8	4600	7	8	45 / 47	90 / 140

TECHNICAL SHEET

- T-close[®] connector → Glass-filled Pa Tech
- ✓ 100% Dyneema[®] rope pre-stretched, coated → Light grey / black
- Finish according to use :
 - ✓ Light / coated light grey or black
 - ✓ Intensive / coated and polyester sheath cover
- Technical / coated and sewn Dyneema[®] 48 plaits cover
- Accessories :
 - ✓ Block[®] Ring → flexible thermoplastic TPE
 - ✓ Twist-lock[®] → Velcro strap

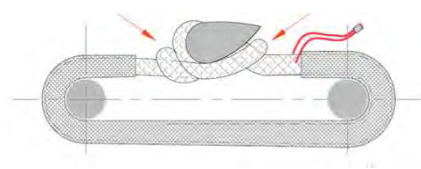

USE

- Textile connector for linking two elements: sheets, halyards, mainsail planks, headsails, tackle, etc.
- Easy to use → Closes with the Cap Knot[®] → Opens quickly even under heavy load

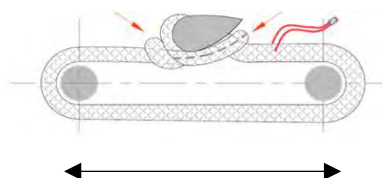

Information sail@nodusfactory.com

NODUS
FACTORY

MADE IN FRANCE

www.nodusfactory.com



Scan me !

Shackle C[®] - Halyard & Sheet

« Dyneema[®] textile connector »



Textile C[®] shackle in pre-stretched and coated Dyneema[®] specially designed for halyards and sheets with an eye terminal.

Advantages

- ❑ Very good UV factor 5 and abrasion resistance
- ❑ The flexibility of the textile ensures that the work is in line with the axes of the efforts
- ❑ 10 x lighter than a stainless steel shackle of equivalent strength
- ❑ Veritas-certified resistance

Specifications

- Dyneema[®] connector with self-locking safety closure (See tutorial)
- Can be used with Block[®] Ring or security toggle
- No need for a halyard stop, thanks to the T-close[®] dog bone

Nodus Tips

- Upgrade your existing sheets and halyards with our ready-to-match lines

References

Standard	
C 3	20006
C 5	20007
C 6	20008
C 8	20009

Intensive	
C 3 + gaine poly	20301
C 5 + gaine poly	20302
C 6 + gaine poly	20303
C 8 + gaine poly	20304

Technical	
Cs 3 + gaine Dyn	20199
Cs 5 + gaine Dyn	20200
Cs 6 + gaine Dyn	20201
Cs 8 + gaine Dyn	20202

NODUS
FACTORY
MADE IN FRANCE

Parc d'Activités de Laroiseau • 5 rue Ella Maillart • F- 56000 Vannes
Tél : +33 (0)2 97 67 64 83 • Mail : sail@nodusfactory.com www.nodusfactory.com



Shackle MHL® - flexible Dyneema® shackle

« Textile sheathed connector »



Product Name	Breaking Load		Weight	Length L			Sheave Ø	Sail Area
	SK78	SK99		S	M	L		
	Direct	Direct		S	M	L	Cons.	40 kts
	kg	kg	gr	cm	cm	cm	mm	R2/m2
M 8 HI	3600	4800	12	4,5	9	10	30/40	100
M 10 HI	6000	8000	21	5	10	12	40/50	170
M 12 HI	6700	10000	42	6	12	14	50/60	185
M 14 HI	10000	14000	67	6	14	16	60+	300

TECHNICAL SHEET

- T-bône® connector
- ✓ Hard anodized 7075 aluminium
- 100% Dyneema® core and sheath
- ✓ SK78 or SK99 12 plaits pre-stretched, coated ↪ Light grey / black
- ✓ Block® ring ↪ flexible thermoplastic TPE

M HL shackle range:

- Coating for general use
- Technical use: "Dyneema® 48 plaits Surge".



USE

- Ideal as a flexible textile connector for mainsail headstays, blocks, low-friction rings, backstay connections, etc.
- Secure shackle eye closure with Block® Ring or Twist-Lock®.

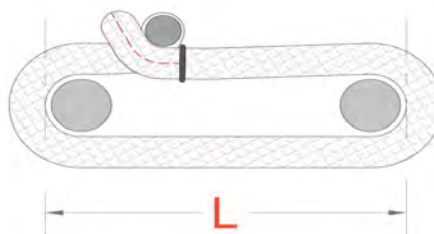

Information sail@nodusfactory.com

NODUS
FACTORY

MADE IN FRANCE

www.nodusfactory.com



Scan me !

Shackle MHL® - flexible Dyneema® shackle

« Textile sheathed connector »



M® High Load is a multi-purpose Dyneema® textile shackle for heavy loads. The technical feature of the M® shackle is that it is both core and sheath, providing greater strength and better protection than a conventional textile shackle.

Advantages

- ❑ Ease of use → Closure → Cap® knot → Quick opening even under heavy load
- ❑ The flexibility of the textile ensures that the work is in line with the axes of the efforts
- ❑ High UV resistance and excellent abrasion resistance

Technical information

- ❑ coated Dyneema® for better protection and durability of the textile fiber
- ❑ The length corresponds to the closed textile shackle
- ❑ The indicated load is the breaking load.
- ❑ Block®Ring, clamping and retaining ring, made of flexible Thermoplastic TPE, for quick clamping and securing of a low-friction ring.

References

SK78	SMALL	MEDIUM	LARGE
M6	20018	20023	20028
M8	20019	20024	20029
M10	20020	20025	20030
M12	20021	20026	20031
M14	20022	20027	20032

Nodus Tips

- Optimise your shackle by checking the sheave size, CMU or BWL of your pulleys!



Parc d'Activités de Laroiseau • 5 rue Ella Maillart • F- 56000 Vannes
Tél : +33 (0)2 97 67 64 83 • Mail : sail@nodusfactory.com www.nodusfactory.com



Shackle Ms_{HL}[®] – Sheathed and coated connector

« High-load overbraided textile connector »

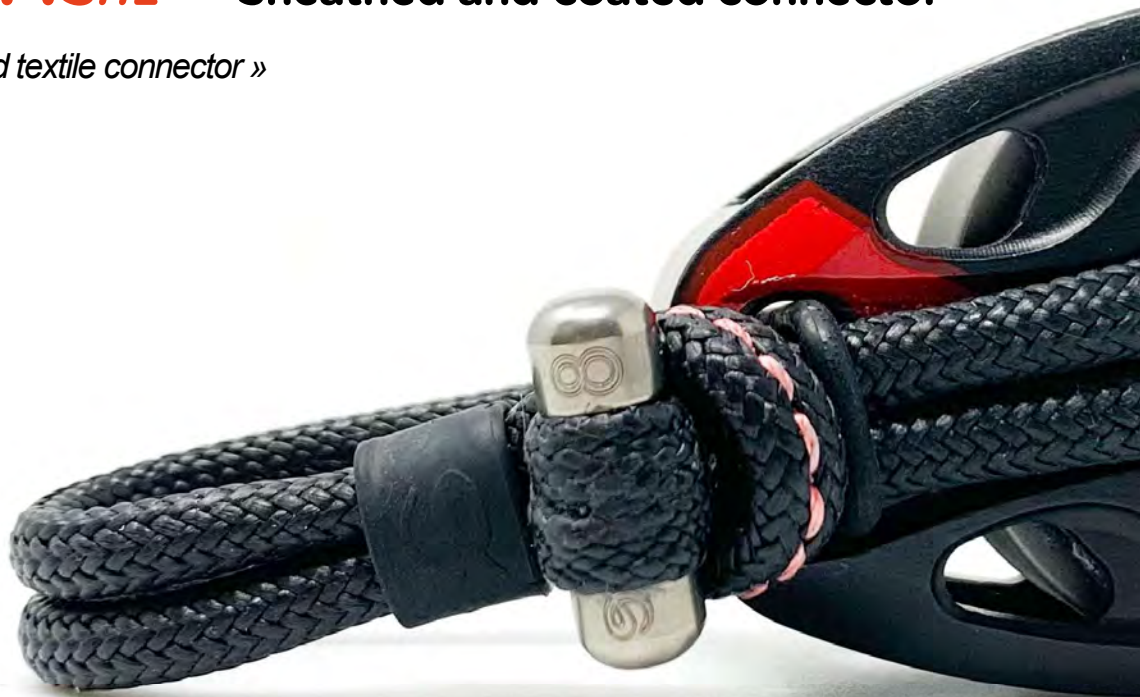

Product Name	Breaking Load SK78	Breaking Load SK99	Weight	Length L			Sheave Ø	Sail Area
				S	M	L		
	Direct	Direct		cm	cm	cm		40 kts
	kg	kg	gr	cm	cm	cm	mm	m2
Ms 8 HI	4000		16	8	10	12	30/40	100
Ms 10 HI	6000	8000	29	8	10	12	40/50	200/220
Ms 12 HI		10000	45	10	12	14	50/60	275
Ms 14 HI		14000	69		14	16	60+	380

TECHNICAL SHEET

- T-bône® connector
- ✓ Hard anodized 7075 aluminium
- 100% Dyneema® core
- ✓ SK78 or SK99 12 plaits pre-stretched, coated ↗ Light grey / black
- 100% Dyneema® sheath
- ✓ SK78 48 plaits coated black
- ✓ Block® ring ↗ flexible thermoplastic TPE

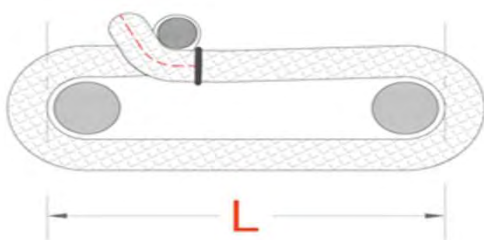

USE

- Ideal as a flexible textile connector for Mainsail edge, blocks, hoists, runner connections, forestay bases, etc.
- Secure shackle eye closure with Block® Ring or Twist-Lock®.



Information sail@nodusfactory.com

NODUS
FACTORY

MADE IN FRANCE

www.nodusfactory.com



Scan me !

Shackle Ms^{HL}® – Sheathed and coated connector

« High-load overbraided textile connector »



Ms® High Load, is a multi-purpose Dyneema® textile shackle for heavy loads.

➤ The special feature of this product is that it is overbraided for extra protection and exceptional durability.

Use

❑ Ideal as a flexible textile connector for pulleys, halyards, runners, forestays, hoists, etc.

Advantages

- ❑ Easy to use → Closure → Cap® knot → Quick opening even after heavy load
- ❑ The flexibility of the textile ensures that the work is in line with the axes of the efforts
- ❑ The eye of the shackle is securely closed by a lock-ring joint
- ❑ UV and abrasion resistant

Specifications

- ❑ T-bone® connector, hard anodized aluminium 7075
- ❑ Textile shackle, core and sheath 100% Dyneema® SK78 or SK99 12 plaits pre-stretched coated → Grey black
- ❑ Textile sheath 100% pre-stretched Dyneema® SK78 48 plaits & enzymatic protective coating → Black
- ❑ Block® ring → flexible thermoplastic TPE Connector T-bone®, hard anodized aluminium 7075

References

SK78	SMALL	MEDIUM	LARGE
Ms8	20033	20035	20037
Ms10	20034	20036	20038
Ms12	20180	20178	20039
Ms14		20179	20040

Nodus Tips

➤ Optimise your shackle by checking the sheave size, CMU or BWL of your pulleys !



Parc d'Activités de Laroiseau • 5 rue Ella Maillart • F- 56000 Vannes
Tél : +33 (0)2 97 67 64 83 • Mail : sail@nodusfactory.com www.nodusfactory.com



Shackle R® - Tackel shackle Block

« Textile connector & low-friction ring »



Product Name	Breaking Load	Weight	Length	Recommended line Ø	Sail Area
	Straight		Closed	Halyard/Sheet	40 kts
	kg	gr	cm	mm	m2
R 3	700	7	10	4/6	20
R 5	1750	10	14	6/8	50
R 6	2500	12	20	8/10	75

TECHNICAL SHEET

- T-close® connector
- glass-filled PA Tech
- 100% Dyneema®
- SK78 12 plaits pre-stretched, coated ↪ Light grey / black
- Technical range, 100% Dyneema® sheath
- SK78 48 plaits coated black
- FRD low-friction ring in hard anodized aluminium
Dark grey/black
- Block® ring ↪ flexible thermoplastic TPE



USE

- Halyard shackle, 2:1 flying block type, for reefing halyards, tack lines, barber-haulers, etc.
- Quick to fit on chainplate, bridges and shroud rails for sheeting.
- Easy to use ↪ Closure ↪ Cap® knot ↪ Quick opening even after heavy load

Information sail@nodusfactory.com

NODUS
FACTORY
MADE IN FRANCE

www.nodusfactory.com



Scan me !

Shackle R[®] - Tackel shackle Block

Textile connector & low-friction ring



R[®] shackle, Dyneema[®] reefing shackle with FrD low friction ring.

❑ For use with reefed mainsail halyard, foot (2:1 tackle)...

Advantages

- ❑ Extremely light and strong friction ring hoist
- ❑ The flexibility of the textile ensures that the work is in line with the axes of the efforts

Technical information

- ❑ T-close[®] connector, ▸ Glass-filled Pa Tech
- ❑ Rope, 100% pre-stretched Dyneema[®] SK78, coated ▸ Light grey/black
- ❑ Low-friction ring, hard anodized aluminium ▸ Grey/black.

References

Shackle R3	20343
Shackle R5	20345
Shackle R6	20346

Nodus Tips

- Choose your reefing shackle according to the diameter and strength of your rope!

NODUS
FACTORY
MADE IN FRANCE

Parc d'Activités de Laroiseau • 5 rue Ella Maillart • F- 56000 Vannes
Tél : +33 (0)2 97 67 64 83 • Mail : sail@nodusfactory.com www.nodusfactory.com



Shackle R-Nub® - flexible tackel Shackle

"Textile connector & low-friction pulley «



Product Name	Breaking load	Weight	Length	Ø Advisable rope	Sail area
	Straight		Closed	Halyard / sheet	40 kts
	kg	gr	cm	mm	m2
R 6 Nub	2500	12	12	8/10	75
R 8 Nub	3600	12	14	10/12	100

TECHNICAL SHEET

- T-close® connector
- ✓ glass-filled PA Tech
- 100% Dyneema® fiber
- ✓ SK78 12 plaits pre-stretched, coated ↪ Light grey / black
- Technical range, 100% Dyneema® sheath
- ✓ SK78 48 plaits coated black
- Nub® low-friction pulley in black technical polymer
- Block® ring ↪ flexible thermoplastic TPE

USE

- Halyard shackle, 2:1 flying block type, for reefing halyards, tack lines, barber-haulers, etc.
- Quick to fit on chainplate, padeyes and shroud rails for sheeting.
- Easy to use ↪ Closure ↪ Cap® knot ↪ Quick opening even after heavy load

Information sail@nodusfactory.com

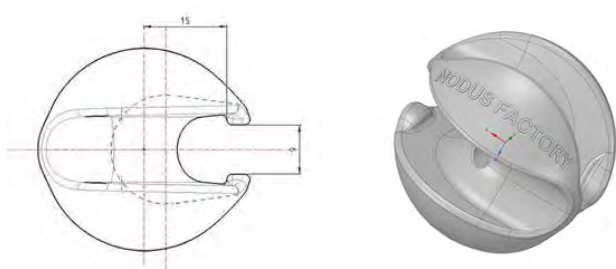

NODUS
FACTORY

MADE IN FRANCE

www.nodusfactory.com



Scan me !

Shackle R-Nub® - flexible tackel Shackle

"Textile connector & low-friction pulley «



Nub® R shackle, Dyneema® reefing shackle and Nub® low-friction block.
For use with reefed mainsail halyards, tackles (2:1 tackle)...

Advantages

- ❑ Extremely light and strong friction block hoist
- ❑ The flexibility of the textile ensures that the work is in line with the axes of the efforts

Technical information

- ❑ T-close connector, ▸ Glass-filled Pa Tech
- ❑ Rope, 100% pre-stretched Dyneema® SK78, coated ▸ Light grey / black
- ❑ Low-friction pulley, in technical polymer ▸ Black.

References

Reeving flexible shackle R5 Nub	20345
Reeving flexible shackle R6 Nub	20346

Nodus Tips

- Choose your R Nub® reefing shackle according to the diameter and strength of your rope !



Parc d'Activités de Laroiseau • 5 rue Ella Maillart • F- 56000 Vannes
Tél : +33 (0)2 97 67 64 83 • Mail : sail@nodusfactory.com www.nodusfactory.com



Textile® Snap hooks



Dyneema® carabiners

Our Dyneema® textile carabiners are quick-release, or releasable under load: high-performance textile fittings.



Textile carabiners can be used for halyards and sheets as well as for mooring your yacht.



1. The carabiner is a textile connector with a specific purpose and comes in a range of sizes depending on the type and sail area being used.
2. Your choice should be made according to the use
3. Dyneema® Nodusfactory™ textile carabiners have many advantages: lightness, mechanical strength, UV resistance and excellent abrasion resistance.



Indication of use and repairability!

Use criteria

The Nodus Factory criterion is based on wear resistance or breaking strength.

- Current - C
- Intensive - I
- Technical - T (S & HL)

Repairability index

Category 1:

Repair only by Nodusfactory™, concerns Dyneema® textile fiber (textile shackle on connector).

- Return us the connectors

Category 2:

Repair by the user, concerns part of the product components (sheath, tying string, Block® Ring, Twist Lock® strap,...)

- Sale of components online

Category 3:

Repair by user, concerns all product components that can be replaced

- Sale of components online

Please note :

Loop-type Dyneema® textile connectors are not repairable and are not included in our index criteria.

- Dyneema® T-Close and M textile shackles are factor 1 (except for intensive use).

However, Dyneema® textile loops and locks® combined with one or more accessories fall into category 3.

M T-close® - Halyard and sheet carabiner

« Dyneema® Halyard & Sheet Connector »



Product Name	Breaking Load	Weight	Length L	Eye Ø	Sail area
	Direct		Closed		40 kts
	kg	gr	cm	mm	m2
M T-c 3	600	4	9	20	30
M T-c 5	1600	10	12	25	50
M T-c 6	2200	18	14	30	70
M T-c 8	3300	36	17	40	100

TECHNICAL SHEET

- T-close® connector
- ✓ glass-filled PA Tech
- 100% Dyneema®
- ✓ SK78 12 plaits pre-stretched, coated ↗ Light grey / black
- Technical range, 100% Dyneema® sheath
- ✓ SK78 48 plaits coated black
- Block® ring ↗ flexible thermoplastic TPE

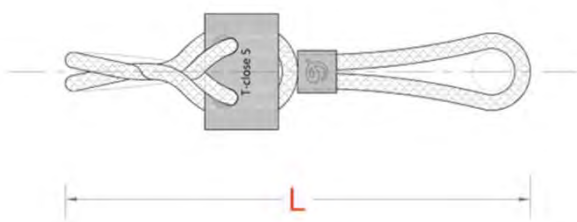

USE

- Quick snap shackle for halyards, jib sheets, genoa, reefing, reaching, etc.
- The snap shackle attaches directly to the lark's head:
- on halyard and sheet with eye terminal
- On chainplate and jib track

Information sail@nodusfactory.com

NØDUS
FACTORY

MADE IN FRANCE

www.nodusfactory.com



Scan me !

M T-close® - Halyard and sheet carabiner

« Dyneema® Halyard & Sheet Connector »



M T-close, textile Dyneema® carabiner for halyard and sheet.

- Quick, effortless opening and closing
- No halyard stopper required

Advantages

- ❑ Lightweight and quick to install
- ❑ The flexibility of the textile ensures that the work is in line with the axes of the efforts
- ❑ Easy to use → Closure → Cap® knot → Quick opening
- ❑ Highly resistant to UV and abrasion

Technical information

- ❑ T-close connector → glass-filled PA Tech
- ❑ f100% Dyneema® SK78 pre-stretched rope, coated → Light grey / black
- ❑ Block® ring - flexible thermoplastic TPE

References

M T-c3	20047
M T-c5	20048
M T-c6	20049
M T-c8	20050

Nodus TIPS

- Use the T-close® carabiner when reefing on the tack

NODUS
FACTORY
MADE IN FRANCE

Parc d'Activités de Laroiseau • 5 rue Ella Maillart • F- 56000 Vannes
Tél : +33 (0)2 97 67 64 83 • Mail : sail@nodusfactory.com www.nodusfactory.com



Snap shackle T-sail® - Spi & gennaker

« Dyneema® connector »



Product Name	Breaking load	Weight	Length L	Ø eye sheet	Sail area
	Tête d'alouette		Droite	Utile	40 kts
	kg	gr	cm	mm	m2
M T-Sail 5	1000	8	10	35	60
M T-Sail 6	1700	18	11	40	90
M T-Sail 7	2700	32	12	45	140

TECHNICAL SHEET

- T-Sail® connector, Pa Tech black
- 100% Dyneema®
- ✓ SK78 pre-stretched, coated 12 plaits → Light grey/black
- T-Sail S model → with Dyneema® sheath SK78 36 plaits
- Block® ring - flexible thermoplastic TPE

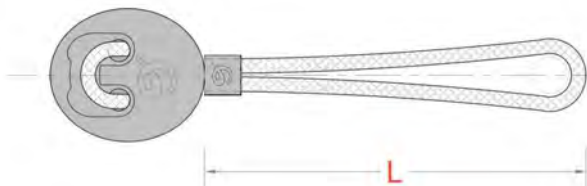

USE

- Designed for downwind sail sheets with eye terminations:
 - To attached directly to the head of the lark on the sheet, requires the use of our Textile-Block® attachment system on the sail.
 - To attach directly to the sail at the head of the lark (clew) requires an eye at the end of the sheet, see table.

Information sail@nodusfactory.com

NØDUS
FACTORY
MADE IN FRANCE

www.nodusfactory.com



Scan me !

Snap shackle T-sail® - Spi & gennaker

« Dyneema® connector »



M T-sail®, snap-shackle for spinnakers and gennakers

➤ is easy to use, extremely lightweight and simple to install.

Advantages

- ❑ Very light and resistant
- ❑ Opening and ultra-fast locking system

Nodus Tips

- Use the T-sail® to reef your jib tack
- Order your sheets from Nodus Factory, the eye will be adapted to your T-Sail snap shackle delivered with the Block® ring.

References

M T-S5	20053
M T-S6	20054
M T-S7	20055

Option

- ❑ Textile-Block®: attachment device designed for the sail clew (ring, strap, etc.). Loop made of Dyneema® and supplied with a Block® Ring locking ring.

NODUS
FACTORY
MADE IN FRANCE

Parc d'Activités de Laroiseau • 5 rue Ella Maillart • F- 56000 Vannes
Tél : +33 (0)2 97 67 64 83 • Mail : sail@nodusfactory.com www.nodusfactory.com



Snap shackle T-drop® - Release under load

« "Dyneema® carabiner for release under load »



Product Name	Breaking Load	Weight	Length T-drop	Total Length	Sail area
			fermé		25 kts
	kg	gr	cm	cm	M2
M T-d 12	800	22	9	18	75

TECHNICAL SHEET

- T-drop® connector, Pa Tech black
- 100% Dyneema®
- ✓ SK78 pre-stretched, coated 48 plaits → black

Option

- Textile-Block®: attachment device designed for the sail clew (ring, strap, etc.). Loop made of Dyneema® and supplied with a Block® Ring locking ring.

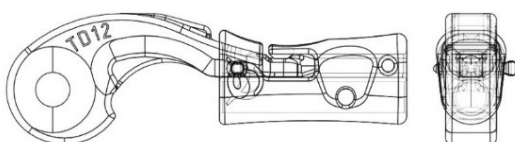

USE

Snap hook to open under load to connect two elements :

- ✓ spi, gennaker.
- ✓ Ideal as a carabiner for a wire

Information sail@nodusfactory.com

NODUS
FACTORY

MADE IN FRANCE

www.nodusfactory.com



Scan me !

Snap shackle T-drop® - Release under load

« "Dyneema® carabiner for release under load »



M T-drop® is a load release carabiner for light winds and light sails.

- Very light, easy to use, with secure pin closure.
- No opening pin required.

Advantages

- Can be released under load, does not jam
- Possibility of fitting a release line (pull cord)
- Very light

References

M-Tdrop	20056
----------------	--------------

Nodus TIPS

- Attaching to the sail → The pelican hook is placed directly in the clew or halyard or via a Textile-Block®.
- Closing the carabiner → Push up the locking ring, secure with the pin
- Releasing under load → Remove the safety pin, pull on the locking ring



NODUS
FACTORY
MADE IN FRANCE

Parc d'Activités de Laroiseau • 5 rue Ella Maillart • F- 56000 Vannes
Tél : +33 (0)2 97 67 64 83 • Mail : sail@nodusfactory.com www.nodusfactory.com



Mf® T-close - Jib sail carabiner

« Dyneema® jib rings »



Product Name	Breaking Load	Weight	Length luff/stay	Sail area
	Straight		Closed Loop	40 kts
	kg	gr	mm	m2
Mf 3.2	500	4	20	60
Mf 3.4	500	5	40	60
Mf 3.6	500	6	60	60
Mf 5.4	800	11	40	110
Mf 5.6	800	12	60	110

TECHNICAL SHEET

- T-close® connector
- ✓ glass-filled PA Tech
- 100% Dyneema®
- ✓ SK78 12 plaits pre-stretched, coated ↪ Light grey / black
- Lock-Ring® seal ↪ EPDM UV resistant

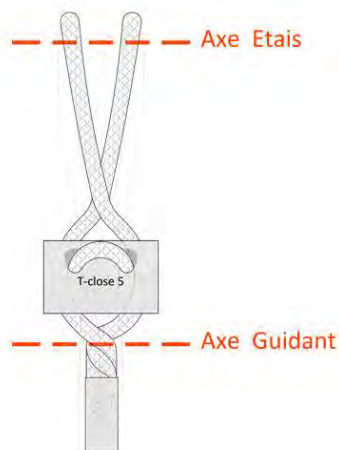

USE

- Jib hitch for securing a headsail ~ ideal for jibs, stormjibs, staysails, etc.
- Great replacement for metal jib hanks and rings
- Easy to use, one-hand closure ↪ Cap Knot® ; Quick opening

Information sail@nodusfactory.com

NODUS
FACTORY

MADE IN FRANCE

www.nodusfactory.com



Scan me !

Mf® T-close - Jib sail carabiner

« Dyneema® jib rings »



Mf T-close is a jib snap shackle, also known as a jib ring, ideal for securing headsails to metal or textile forestays.

➤ Fitted directly onto the sail's eyelet, seamless, captive and quick and easy to fasten.

Advantages

- Waterproof: secure closure with lock-ring seal
- Excellent abrasion resistance on metal or textile forestay
- 10 x lighter than a metal jib hanger with equivalent strength
- Prevents rust on sails
- Does not damage decks
- Easy to use → Closure → Cap® knot → Quick opening

References

Mf 3.2	20041
Mf 3.4	20042
Mf 3.6	20043
Mf 5.2	20044
Mf 5.4	20045
Mf 5.6	20046

NODUS
FACTORY
MADE IN FRANCE

Parc d'Activités de Laroiseau • 5 rue Ella Maillart • F- 56000 Vannes
Tél : +33 (0)2 97 67 64 83 • Mail : sail@nodusfactory.com www.nodusfactory.com



Textile Loop & Lock®



Dyneema® textile Loops & Locks®

Discover our textile fittings dedicated to leisure sailing, boating, blue water cruising, regattas and ocean racing.



Nodus Factory offers you a complete range of textile Loops, Locks® and Textile Fuse connectors - patented products developed by our R&D team.



Reliable, robust and certified products designed for sailing, often copied but never equalled.



Our Locks® loops and connectors are "forged in the metal of the future", Dyneema® and Technora®, and are the ideal accessories for rigging and equipping your yacht.



Nodus Factory™ uses the excellence of new-generation materials from aerospace, aeronautics and ocean racing.



Our "Lock®" zippable eye loops and textile connectors are tomorrow's universal 4.0 fittings, ideal as multi-purpose flexible connectors for :
Pulleys, low-friction rings (Polymer, duralumin or 4.0 iTech PO), Nub pulley, etc...

Load forces as a function of deflection angle!

When choosing fittings or ropes for your deck layout, you should bear in mind that the force exerted by the rope on a block, friction ring or Nub must take into account a coefficient determined by the angle of the forces exerted by the rope. (see table below)

For example:

A low-friction ring that returns a rope at 180° is subjected to a load equal to 2 x its load, On the other hand, when a rope is returned at 30° with a Barber Hauler, a return block or a Hook, the load is only 52%.

At the foot of the mast, it is preferable to use Duralumin or Nub® rings rather than resin rings, as they are subjected to greater forces at 90°, i.e. x 140%.

Remember that the maximum sail area values given in our tables should be reduced by 40% to choose your low-friction rings.

Comparative table :

Deflection angle	Coefficient of load
180°	200%
160°	197%
140°	187%
120°	173%
90°	141%
75°	122%
60°	100%
45°	76%
30°	52%
20°	35%

The sail area values given in our tables must take into account both the angle of the forces given by the rope and the wind speed, just a reminder...!

Loop HL[®] - Sheathed Dyneema[®] loop

« High-load Dyneema[®] loop connector »



Product Name	Breaking Load		Weight	Length L					Sheave
	Basket	Basket		XS	S	M	L	XL	Inside Ø
	DSK78 kg	DSK99 kg	gr	cm	cm	cm	cm	cm	Pulley
L 2.5 HI	2000	3000	3	14	16	19	22		20
L 3 HI	3800	5500	4		16	19	22		30
L 4 HI	6300	9500	11		16	19	22	28	40
L 5 HI	8000	12500	18			19	22	28	50
L 6 HI	9500	14000	24			19	22	28	60

TECHNICAL SHEET

- 100% Dyneema[®]
- ✓ SK78 12 plaits pre-stretched, coated → Light grey / black
- Technical range, 100% Dyneema[®] overbraided
- SK78 48 plaits coated black



- Accessory
- ✓ Block[®] ring → flexible thermoplastic TPE
- ✓ Twist-Lock[®] velcro strap

USE

- Textile connector for outhaul and jib blocks, boom and spar blocks (spinnaker pole, bowsprit, etc.), backstay and runners to tackle blocks.
- Ideal for webbing blocks and low-friction rings used as "return blocks".

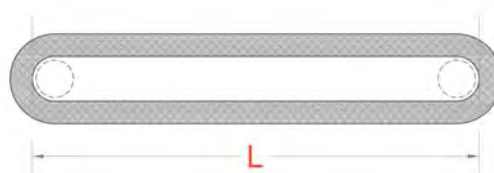

Information sail@nodusfactory.com

NØDUS
FACTORY

MADE IN FRANCE

www.nodusfactory.com



Scan me !

Loop HL[®] - Sheathed Dyneema[®] loop

« High-load Dyneema[®] loop connector »



The "High Load" Dyneema[®] -sheathed Loop[®] is a textile ring, ideal as a flexible connector.

- The special technical feature of our Loop[®] is that it is both core and sheath, providing greater strength and better protection than a conventional loop.
- The loop is available in Dyneema[®] SK78 or SK99 for a breaking load adapted to your needs.

Advantages

- ❑ Very light, excellent tensile strength and breaking strength
- ❑ The flexibility of the textile ensures that the work is in line with the axes of the efforts
- ❑ Highly UV-resistant and excellent abrasion resistance

Technical information

- ❑ Textile loop, core and sheath 100% pre-stretched Dyneema[®] 12 plaits, coated → Light grey / black
- ❑ Block[®] ring → flexible thermoplastic TPE
- ❑ Usa category according to your needs: standard / intensive / technical

References

HL	X SMALL	SMALL	MEDIUM	LARGE	X LARGE
L2,5	20168	20171	20062	20067	
L3		20058	20063	20068	
L4		20059	20064	20069	20072
L5		20060	20065	20070	20073
L6		20061	20066	20071	

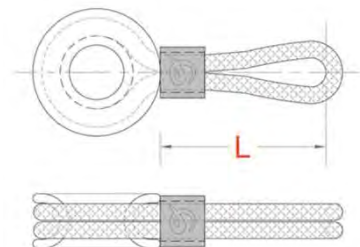

Nodus Tips

- Optimise your loop by checking the sheave size, CMU or SWL of your pulleys!



Parc d'Activités de Laroiseau • 5 rue Ella Maillart • F- 56000 Vannes
Tél : +33 (0)2 97 67 64 83 • Mail : sail@nodusfactory.com www.nodusfactory.com



Loop S HL[®] « with sheath » - Loop High load

« Overbraided Dyneema[®] loop for high loads »



Product Name	Breaking Load		Weight	Length L				Sheave Inside Ø
	Basket	Basket		XS	S	M	L	
	SK78 kg	SK99 kg	Gr	cm	cm	cm	cm	Pulley mm
Ls 2 HI	2000	3000	10	7	20	22		20-30
Ls 3 HI	3800	5500	13	9	20	22		30-50
Ls 4 HI	6300	9500	19	11	20	22	26	50-60

TECHNICAL SHEET

- 100% Dyneema[®] long-braided core
- ✓ SK78 12 plaits pre-stretched, enzyme-coated ▾ Light grey / black
- ✓ SK99 12 plaits pre-stretched, coated ▾ Light grey / black
- 100% Dyneema[®] cover
- ✓ SK78 48 plaits coated black
- Protect Coating[®] treatment - Polymer hardener
- Accessories
- ✓ Block[®] ring ▾ flexible thermoplastic TPE
- ✓ Twist-Lock[®] velcro strap

USE

- Textile connector for clew, jib, boom and spar track blocks (spinnaker pole, bowsprit, etc.) connecting backstays and runners to tackle blocks.
- Ideal for webbing blocks

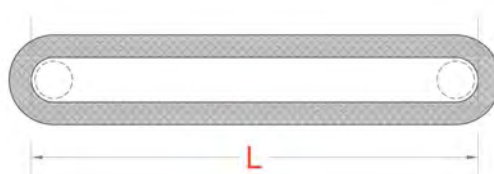

Information sail@nodusfactory.com

NODUS
FACTORY

MADE IN FRANCE

www.nodusfactory.com



Scan me !

Loop S HL[®] « with sheath » - Loop High load

« Overbraided Dyneema[®] loop for high loads »



Loop[®] High Load in Dyneema[®] SK78 or SK99 is a textile ring for high loads, ideal as a flexible connector.

- The special feature of this product is that it is manufactured with a Dyneema[®] protective sheath and a Protect-Coating Polymer[®] treatment.

Advantages

- ❑ Very light, excellent tensile strength and breaking strength
- ❑ The flexibility of the textile ensures that the work is in line with the axes of the efforts
- ❑ Highly UV-resistant and excellent abrasion resistance

Technical information

- ❑ 100% Dyneema[®] 12 plaits pre-stretched, coated core ⇨ Light grey / black
- ✓ Oversheath in pre-stretched, coated Dyneema[®] 48 plaits ⇨ black
- ❑ Accessories
- ✓ Block[®] ring ⇨ flexible thermoplastic TPE

References

HL	X small	SMALL	MEDIUM	LARGE
Ls2	20084	20087	20090	
Ls3	20085	20088	20091	
Ls4	20086	20089	20092	20093

Nodus Tips

- Choose your loops by checking the sheave size, CMU and SWL of your pulleys!



Parc d'Activités de Laroiseau • 5 rue Ella Maillart • F- 56000 Vannes
Tél : +33 (0)2 97 67 64 83 • Mail : sail@nodusfactory.com www.nodusfactory.com



Textile Lock® - Fastener with adjustable eye

« Adjustable, universal Dyneema® loop for low-friction rings »



Product Name	Breaking Load Kg	Weight	Length L (+/- 5mm)	
	Basket			Max
	kg	gr	cm	mm
Lock 3	3800	14	16	30
Lock 4	6300	21	22	40
Lock 5	8000	51	28	45

TECHNICAL SHEET

- Fastener with adjustable eye, 100% pre-stretched Dyneema® SK78 12 plaits, coated → Light grey / black
- System-Lock®
- ✓ Intensive overbraided PES (Lock), 100% HD polyester Black & Orange
- ✓ Technical Dyneema® (lock), 100% Dyneema® SK78 48 plaits → Black
- Twist-Lock® accessory
- ✓ Velcro® Polypropylene & Velour PA

Textile strap for friction Rings and Nub®

Lock 3 → Ø ring FR10 (static use) /FRD10 (dynamic use)

Lock 4 → Ø ring FR14 (static use) /FRD14 (dynamic use)

Lock 5 → Ø ring FR20 (static use) /FRD20-25 (dynamic use) / Nub 40



L

INSTALLATION

1. Open the Textile-Lock by sliding the sheath downwards.
- 2- Fit the accessory (friction ring, NUB, etc.).
- 3-Put the product in position with the two strands around the accessories, trigger guard, chainplate, reefing catch, etc.
- 4-Close the Textile-Lock on the ring by sliding the sheath upwards.
- 5-Lock the rope strands with the Twist-Lock® accessory.



Information sail@nodusfactory.com

NODUS
FACTORY

MADE IN FRANCE

www.nodusfactory.com



Scan me !

Textile Lock® - Fastener with adjustable eye

« "Adjustable, universal Dyneema® loop for low-friction rings »



The **Textile Lock-B®** is a Dyneema® textile connector with an adjustable, self-tightening constrictor eye designed to quickly and securely attach low-friction rings without spicing.

- A bi-stranded flexible textile connector for high loads ideal for reefing hooks placed on top of the boom fitting axis.

Perfect for connecting your friction rings and for reefing on the mainsail

Applications

- Dyneema® textile connector with adjustable eye for low-friction rings of different sizes (see table)
- Double-strand basket or single-strand lark's head attachment

Advantages

- No spicing skills required to attach a ring
- Unique Loop / Dyneema® loop with adjustable eye and positive safety in boating
- Easy to use, reversible → Symmetrical buckle → Secure closure on both sides
- Abrasion and UV resistant

References

LOCK 3i	20254
LOCK 3t	20255
LOCK 4t	20252
LOCK 5t	20256



NODUS
FACTORY
MADE IN FRANCE

Parc d'Activités de Laroiseau • 5 rue Ella Maillart • F- 56000 Vannes
Tél : +33 (0)2 97 67 64 83 • Mail : sail@nodusfactory.com www.nodusfactory.com



LR[®] - Loop and Ring « Adjustable Dyneema[®] loop »

"Universal adjustable textile connector for low friction ring".



Product Name	Breaking load Kg	Diameter	Lenght L	Ø Eye	Sail area M2
Loop ajustable universel	Dyneema [®] SK78	mm	cm	mm	40 kts
LR 3	1500	3	14	30	90
LR 4	2500	4	17	40	150
LR 5	3000	5	20	60	180

TECHNICAL SHEET

- Adjustable Dyneema[®] loop
- ✓ 100% pre-stretched Dyneema[®] SK78 12 plaits, enzymé → Light grey / black
- ✓ Block[®] ring, flexible TPE thermoplastic

Universal low friction rings

- Static use
- ✓ Fr - Open low friction ring in self-lubricating technical resin → black
- ✓ internal diameter 14mm or 20mm
- Dynamic use
- ✓ FrD -: Low friction ring in hard anodized aluminium → anthracite grey
- ✓ internal diameter 14mm or 20mm

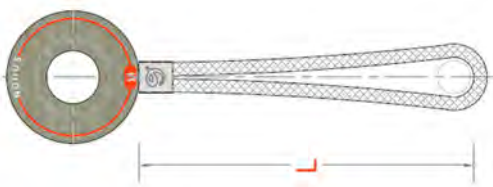

USE

- Adjustable Dyneema[®] loop is the ideal textile accessory for quickly connecting a low-friction ring without splicing.
- Allows you to create halyard or sheet leads
- A universal Dyneema[®] textile connector for low-friction rings that easily replaces a block
- For quick and easy attachment between two components: mainsail foot, windlass, barber-auler, furler, in-hauler, etc.
- Withstands heavy loads

Information sail@nodusfactory.com

NODUS
FACTORY

MADE IN FRANCE

www.nodusfactory.com



Scan me !

LR[®] - Loop and Ring « Loop Dyneema[®] ajustable »

« Adjustable Dyneema[®] connector ajustable for low-friction ring »

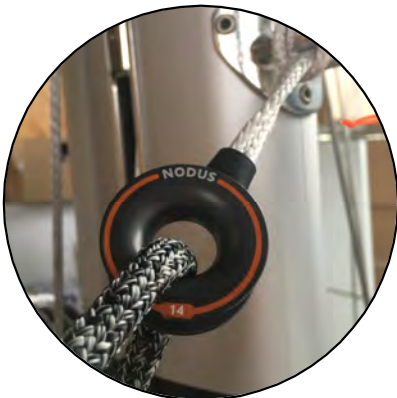

LR[®] is an adjustable loop in Dyneema[®] SK78 to connect with a low-friction ring.

➤ This adjustable Dyneema[®] textile connector for low-friction rings can be used to create halyard or sheet leads.

Attaches quickly and easily to chainplates and jib tracks with a simple lark's head knot.

Advantages

- Easy to install ↪ Fixing ↪ Lark's head knot
- 360° rotation
- Excellent strength to weight ratio
- Reliable and maintenance-free

Accessories " Low friction rings

- Static use
- ✓ Fr - Low-friction open ring in self-lubricating technical resin ↪ black
- Dynamic use
- ✓ FrD -: Low friction ring in hard anodized Duralumin ↪ anthracite grey

References

Loop R3	20217
Loop R4	20214
Loop R5	20215



NODUS
FACTORY
MADE IN FRANCE

Parc d'Activités de Laroiseau • 5 rue Ella Maillart • F- 56000 Vannes
Tél : +33 (0)2 97 67 64 83 • Mail : sail@nodusfactory.com www.nodusfactory.com



Blocker-roller® - Textile adjustment

"Textile blocker for 3D sheet adjustment"



Product Name	Operating load	Wind force		Accessory	Dimension cm	
		kg	25 kts		Mini	Maxi
Blocker-Roller 3 - FRD10	750	4/8 mm	50 m2	Ring FRD 10	12	45
Blocker-Roller 4 - FRD14	900	6/10 mm	70 m2	Ring FRD 14	15	55
Blocker-Roller 5 - FRD20	2500	10/14 mm	100 m2	Ring FRD 20	18	65
Blocker-Roller 4	400	6/10 mm		Option	15	55
Blocker-Roller 5	1200	10/14 mm		Option	18	65

TECHNICAL SHEET

Blocker-Roller® - Adjustable, self-locking textile rope clamp

- ✓ Mixed hollow braid in Dyneema® and PES "HD" 12 plaits, coated and sewn
- ✓ Adjustable buckles with Dyneema® sheath 48 plaits
- ✓ Nodus Factory "Bosco knot" textile shackle connector

Hard anodized aluminium FRD rings or optional Hook-friction accessory.

USE

1-Connect the Blocker-Roller to your deck using our "Bosco" textile shackle.

2- Adjust the power of your genoa:

- ✓ By increasing the length of the Blocker-Roller boom, you raise the clew, which opens the sail and the power comes out the top.
- ✓ Decreasing the length of the Blocker-Roller boom closes the leech, increasing power and heel.

Information sail@nodusfactory.com

NODUS
FACTORY
MADE IN FRANCE
www.nodusfactory.com



Scan me !

Blocker-roller® - Textile adjustment

"Textile blocker for 3D sheet adjustment"



The Nodus Factory™ textile cleat is an adjustable, self-locking Dyneema® braided cleat fitted with a low-friction ring or an open Hook-type ring. It allows you to adjust the height of the clew on the genoa or headsails like a roller on a clew track.

➤ Very light and very strong, it's easy to use and easy to install.

Uses

- The principle is simple: when the tension of your clew increases, the blocking of the Blocker-Roller boom increases.
- Then adjust the length of the boom using the pull loops, the low loop to raise the clew and the high loop to lower the clew.

Advantages

- Multi-purpose textile "wedge cleat" mobile rope clamp
- Easy to adjust the height of the pull point
- Quick and easy to install on rail, trigger guard, chainplate, etc., depending on your deck layout
- Optimized ergonomics, no protruding or aggressive parts
- Improves your deck layout

References

Blocker-Roller FRD10	textile blocker & ring	20225
Blocker-Roller FRD14	textile blocker & ring	20226
Blocker-Roller FRD20	textile blocker & ring	20227
Blocker-Roller Hook14	textile blocker & ring	20228
Blocker-Roller Hook20	textile blocker & Hook	20229

NØDUS
FACTORY
MADE IN FRANCE

Parc d'Activités de Laroiseau • 5 rue Ella Maillart • F- 56000 Vannes
Tél : +33 (0)2 97 67 64 83 • Mail : sail@nodusfactory.com www.nodusfactory.com



Sail-Fuse® - Mainsail shock absorber

« Patented FR2105794 »



Product Name	Length	Fuse breaking load	Breaking load	Roll out length	Boat size
Damper	mm	kg	kg	mm	ml
Sail-Fuse 6	180	600	1 600	900	6 / 8
Sail-Fuse 12	200	1 200	2 500	1 100	8 / 11
Sail-Fuse 18	250	1 800	3 600	1 350	11 / 14

TECHNICAL SHEET

- ❑ 100% Dyneema® webbing
- ✓ 32 plaits pre-stretched, coated ↪ Black
- ✓ HDPE polypropylene sheath

Nodusfactory™ "Sail-fuse®" textile mainsail shock absorbers are made in France and crafted in our workshop by our expert fitters.



Sail-Fuse 6 de 180 mm / 900 mm

Sail-Fuse 12 de 200 mm / 1100 mm

Sail-Fuse 18 de 250 mm / 1350 mm

USE

- ❑ Sail-Fuse, used to connect two components that are subjected to opposing forces during use.
- ❑ Energy-absorbing textile connector to be fixed between the boom and the mainsail tackle.
- ❑ This device is not a substitute for setting "the sail of time", as there is no such thing as zero risk.

Information sail@nodusfactory.com

NØDUS
FACTORY
MADE IN FRANCE

www.nodusfactory.com



Scan me !

Sail-Fuse® - Mainsail shock absorber

« Patented FR2105794 »



The **Sail-fuse®** Nodus Factory™ textile damper is a load fuse and mainsail damper.

➤ The "Sail-fuse®" fuse opens when the "Rupture" intervention load of the damper is exceeded, several models available.

Made from Dyneema® textile webbing with energy absorber in the event of a spontaneous gybe.

Applications

- Sail-Fuse, used to connect two components that are subjected to opposing forces during use.
- Energy-absorbing textile connector to be fixed between the boom and the mainsail tackle.
- This device is not a substitute for establishing "the sail of time", as there is no such thing as zero risk.

Advantages

- Avoid damage to props and stays, which can lead to structural failure of the equipment.
- Passive safety - load transfer
- Weight/strength ratio

References

Sail-Fuse 6	20201
Sail-Fuse 12	20202
Sail-Fuse 18	20203



Parc d'Activités de Laroiseau • 5 rue Ella Maillart • F- 56000 Vannes
Tél : +33 (0)2 97 67 64 83 • Mail : sail@nodusfactory.com www.nodusfactory.com



Friction ring & Nub



Friction rings & Nub®

Which friction ring for which use?

Each friction ring has a specific use, and it is important to check its characteristics to use it properly...!



- See our comparison table

Low-friction rings can easily be fitted to your boat to replace an old block.



Combined with a textile connector: shackle, loop, erse in textile Dyneema® and our locking systems (Twist Lock / Block® Ring), Nodusfactory™ friction rings will provide you with strength, lightness and performance to equip and rig your sailboat.



Nodus Factory Fittings & Tips

Follow the basic rules of seamanship to ensure maximum load on low-friction rings.



- ✓ A larger eye increases the strength of the ring, the angle of the splice to the groove should be at least 15 degrees.



- ✓ The length of the flat eye should be at least 2.7 times the diameter of the ring groove.

FR 10 = 27 mm / FR 14 = 38 mm / FR 20 = 54 mm / FR 28 = 76 mm



- ✓ The textile connector for the ring must be at least 0.6 times the diameter of the groove (loop, shackle, lashing, strop, etc.) The Ø of the sheet or halyard must be at least :

FR 10 = 4 mm / FR 14 = 6 mm / FR 20 = 10 mm

Which friction ring for which use?

Friction rings, or to use the correct terminology, 'low friction rings', will easily find their place on your boat as a replacement for a block (asymmetric spinnaker tack, reefing, cascade, mast foot blocks, etc.).

Combined with our textile connectors: shackle, loop, Dyneema® erse and our locking systems (Twist Lock® / Block® Ring), NodusFactory™ friction rings will provide you with strength, lightness and performance to equip and rig your sailboat.

Made from different materials depending on their intended use, our material comparison will help you choose your ideal low friction ring.

Material	Lifespan	Friction	T° usage	T° Celsius	Dynamic	Static	Material price
ITECH	5/5	5/5	4/5	+ 140° / 180°	5/5	4/5	5/5
ALUMINIUM	4/5	4/5	5/5	+ 180° / 240°	4/5	5/5	4/5
PEEK	4/5	3/5	4/5	+ 140° / 180°	4/5	5/5	3/5
POM	3/5	4/5	2/5	100°	3/5	3/5	2/5
PA66	4/5	3/5	3/5	120°	3/5	3/5	2/5

If you're looking for the No. 1 low-friction ring that performs as well as a basic pulley, the iTech range is for you:

Longer lifespan than metal

- +/- 6900 hours continuous friction
- +/- 200,000 halyard sends, tacking, sail trimming,
- 80% lighter than metal

Friction ring P-Tech® - Low friction ring

« Technical polymer P-Tech® Low / High »



Product Name	Breaking load			Weight	Dimensions				recommended Ø	Sail area M2
	Kg - load angle				gramme	A	B	C		
Polymer	180°	90°	60°		mm				mm	Angle 90°
Low friction										
P-Tech 10	900	1250	1800	2	7	10	12	24	4/6	25
P-Tech 14	1200	1700	2400	4	10	14	16	34	6/8	40
P-Tech 20	1600	2250	3200	16	14	20	22	49	8/14	62

TECHNICAL SHEET

- P-Tech®, low friction ring in self-lubricating resin / black
- ✓ Low Friction → Polymer tech / Thermoplastic POM
- ✓ High friction → Tech polymer / PEEK stable thermoplastic

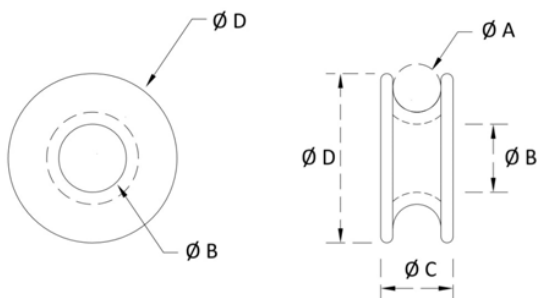

USE

- Dynamic and static use
- 3D headsail adjustment
- Double sheets
- Deck plates & tackle
- ... just about everything, depending on the required loads!

Information sail@nodusfactory.com

NØDUS
FACTORY

MADE IN FRANCE

www.nodusfactory.com



Scan me !

Friction ring P-Tech® - Low friction ring

« technical polymer P-Tech® Low / Hight »



P-Tech®, Nodus Factory® rings are self-lubricating, very light, reliable and highly resistant to friction for dynamic use in high Friction.

➤ They can be used in a wide range of applications with all types of non-abrasive ropes:

- ✓ Static at low speed
- ✓ Dynamic at high speed

Essential on board your yacht with our textile connectors "Loops, Lock®,..." to optimise your deck layout for greater safety and performance.

Advantages

Very low coefficient of friction

- ❑ Dynamic use, very high friction speed - T°C continuous use T °C +140 /180
- ✓ High friction P-tech coefficient of friction 0.40 compared to aluminium 1.35
- ❑ Static use low friction speed - T°C continuous use T °C +80 /100
- ✓ Low friction coefficient P-tech 0.25 compared to aluminium 1.35

References

P-Tech 10 L	20109
P-Tech 14 L	20110
P-Tech 20 L	20111
P-Tech 10 H	20112
P-Tech 14 H	20113
P-Tech 20 H	20114

Nodus Tips

Material	Durability / Wear	Friction	T° use	T° Celsius	Dynamic	Static	Material price
ITECH	5/5	5/5	4/5	+ 140° / 180°	5/5	4/5	5/5
ALUMINIUM	4/5	4/5	5/5	+ 180° / 240°	4/5	5/5	4/5
PEEK	4/5	3/5	4/5	+ 140° / 180°	4/5	5/5	3/5
POM	3/5	4/5	2/5	100°	3/5	3/5	2/5

NODUS
FACTORY
MADE IN FRANCE

Parc d'Activités de Laroiseau • 5 rue Ella Maillart • F- 56000 Vannes
Tél : +33 (0)2 97 67 64 83 • Mail : sail@nodusfactory.com www.nodusfactory.com



Friction ring I-Tech® - Low friction ring

« Low friction ring polymer I-Tech® »



Product Name	Breaking load			Weight	Dimensions				Ø Recommended	Sail area M2
	Kg - load angle				A	B	C	D		
Polymer	Kg - load angle			gramme	A	B	C	D	Sheet	40 kts
High friction	180°	90°	60°		mm				mm	Angle 90°
I-Tech 7	400	600	800	1	5	6	10	18	2/4	10
I-Tech 10	1000	1500	2000	2	7	9	12	24	4/6	25
I-Tech 14	1500	2200	3000	4	9	13	15	34	6/8	40

TECHNICAL SHEET

- I-Tech, low friction ring in lubricating polymer
- ✓ Low Friction → I-Tech self-lubricating technical plastic resin → Ivory / Black tinted
- ✓ 3 components / Base polymer, fibers and solid lubricant filling.

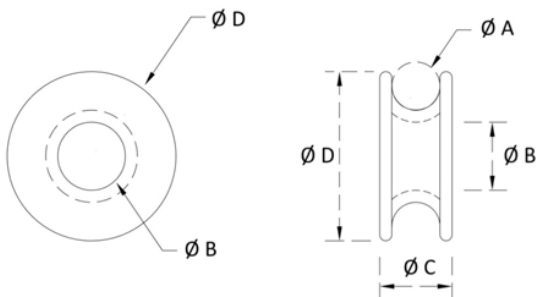

USE

- Dynamic use
- ✓ 3D headsail adjustment
- ✓ Double sheets
- ✓ Deck plates & Hoist
- ✓ ... just about everything, depending on the load requirements

Information sail@nodusfactory.com

NODUS
FACTORY

MADE IN FRANCE

www.nodusfactory.com



Scan me !

Friction ring I-Tech® - Low friction ring

« Low friction ring polymer I-Tech® »



I-Tech®, Nodus Factory™ rings are self-lubricating, very light, reliable and highly resistant to friction for dynamic use.

➤ They can be used in a wide range of dynamic applications with all types of rope.

Essential on board your yacht with our textile connectors "Loops, Lock®,..." to optimise your deck layout for greater safety and performance.

➤ They can be used just about anywhere and with any type of rope.

Advantages

- ❑ Very low coefficient of friction
- ✓ Dynamic use, very high friction speed T°C continuous use T °C +140 /180
- ✓ Coefficient of friction of PO Itech 0.18 compared with aluminium 1.35

References

I-Tech 7	20203B
I-Tech 10	20204B
I-Tech 14	20205B

Nodus Tips

Material	Durability / Wear	Friction	T° use	T° Celsius	Dynamic	Statique	Material price
ITECH	5/5	5/5	4/5	+ 140° / 180°	5/5	4/5	5/5
ALUMINIUM	4/5	4/5	5/5	+ 180° / 240°	4/5	5/5	4/5
PEEK	4/5	3/5	4/5	+ 140° / 180°	4/5	5/5	3/5
POM	3/5	4/5	2/5	100°	3/5	3/5	2/5



Parc d'Activités de Laroiseau • 5 rue Ella Maillart • F- 56000 Vannes
Tél : +33 (0)2 97 67 64 83 • Mail : sail@nodusfactory.com www.nodusfactory.com



Friction Ring FrD[®] - Low friction ring

« Duralumin[®] »



Product Name	Breaking load			Weight	Dimensions				recommended Ø	
	Angle	Kg - load angle			A	B	C	D		
Duralumin		180°	90°	60°	gram				Sheet	
FrD 10		500	950	1000	8	8	12	12	30	4/8
FrD 14		650	1100	1300	16	10	16	16	40	6/10
FrD 25		1700	3100	3400	60	16	24	17	60	12/18

TECHNICAL SHEET

- FrD Low friction Duralumin ring
- ✓ Hard anodizing treatment
- ✓ Friction resistance with a good sliding coefficient under high load
- ✓ Improved rigidity
- ✓ Corrosion resistance (to nickel salt clogging, approx. 300 hours)
- ✓ The hard oxide layer is 50% thicker and 50% embedded in the metal

- Anthracite grey color, orange marking

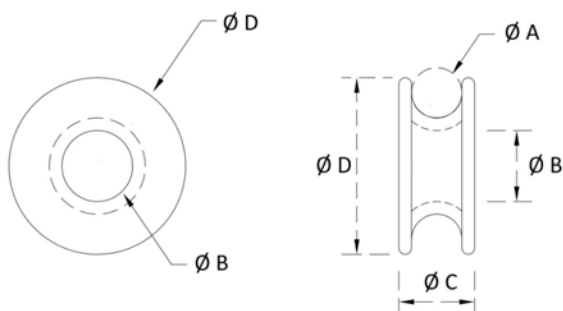

USE

- High load in Dynamic Use
- ✓ 3D headsail adjustment
- ✓ Backstay
- ✓ Downhaul
- ✓ Double sheets
- ✓ Deck plates & tackle
- ✓ ... just about everything!

Follow the basic rules of seamanship to ensure maximum load on low-friction rings.

A larger eye increases the strength of the ring, and the angle of the splice to the groove should be at least 15 degrees.

Information sail@nodusfactory.com

NODUS
FACTORY

MADE IN FRANCE

www.nodusfactory.com



Scan me !

Friction Ring FrD[®] - Friction ring

« Duralumin[®] »



Nodus Factory™ low-friction Duralumin rings are lightweight, reliable and durable. Essential on board your yacht with our textile connectors "Loops, Lock,..." to be able to optimize your deck plan for greater safety and performance.

They are suitable for creating hoists and stunts of all types:

- ✓ Boom downhaul
- ✓ Backstay
- ✓ Genoa trimmers
- ✓ reefing lines

They can be used for just about anything and with any type of rope, although some Technora[®] ropes have an aggressive grip.

Advantages

- High mechanical strength
- Low coefficient of friction

References

FrD 10	20115
FrD 14	20116
FrD 20	20117

Nodus Tips

The angle of the splice: the groove must be at least 15 degrees.

The length of the flat eye must be at least 2.7 times the diameter of the ring groove.

✓ FR 10 = 27 mm / FR 14 = 38 mm / FR 20 = 54 mm / FR 28 = 76 mm

The textile connector for the ring must be at least 0.6 times the diameter of the groove (loop, shackle, lashing, strop, etc.) The Ø of the sheet or halyard must be at least :

✓ FR 10 = 4 mm / FR 14 = 6 mm / FR 20 = 10 mm

NODUS
FACTORY
MADE IN FRANCE

Parc d'Activités de Laroiseau • 5 rue Ella Maillart • F- 56000 Vannes
Tél : +33 (0)2 97 67 64 83 • Mail : sail@nodusfactory.com www.nodusfactory.com



Block-Friction® FrD - Violin ring pulley

« Violin ring - Dyneema® & Duralumin® »



Product Name	Breaking load	Length	Inside Ø	recommended Ø	Sail area
	Direct	Straight	Rings	Halyard / sheet	40 kts
	kg	cm	mm	mm	M2 ≥ 180°
BF 14-10	1600/800	7	14/10	8/6	55
BF 20-14	5000/3600	13	25/20	14/10	100

TECHNICAL SHEET

- FRD low-friction ring, in hard anodized Duralumin
 - anthracite grey
- ✓ FrD10/FrD14 & FrD14/FrD20
- Textile® crimp between rings, 100% Dyneema® core and sheath
- ✓ SK78 12 plaits pre-stretched, coated ▸ Light grey / black
- Block® ring, in flexible TPE thermoplastic

- FRD ring
 - ✓ Friction resistant with a good sliding coefficient under high load
 - ✓ Improved rigidity
 - ✓ Anthracite grey colour, orange marking

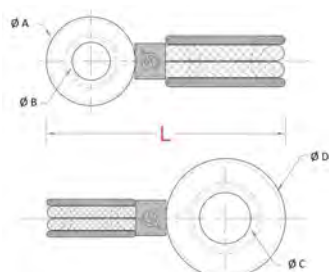

USE

- High load in static & dynamic use
- ✓ Under beard
- ✓ 3D headsail adjustment
- ✓ Backstay
- ✓ Downhaul
- ✓ Double sheets
- ✓ Deck plates & tackle
- ✓ ... just about everything!

The textile connection allows the load to self-align, reducing fatigue.

Information sail@nodusfactory.com

NODUS
FACTORY

MADE IN FRANCE

www.nodusfactory.com



Scan me !

Block-Friction® FrD - Violin ring pulley

« Violin ring - Dyneema® & Duralumin® »

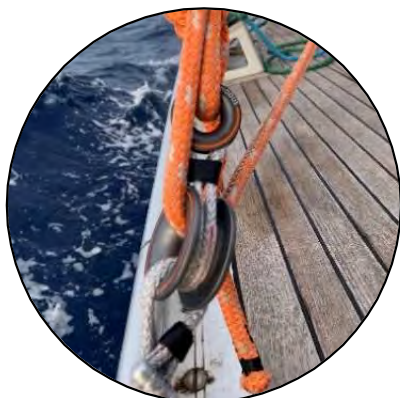

BF®, the Block-Friction® violin ring has an exceptional strength-to-weight ratio (10 times lighter than a pulley), designed for high static loads.

- Block Friction® rings can be used for 3:1 or 4:1 downhaul or mainsail hoists, as well as for cunningham adjustment hoists or sheet point hoists on larger boats.
- Our Violin rings are ideal for applications requiring low rope movement (speed) and a low angle (the greater the deflection, the greater the friction).
- They can be used for just about anything and with any type of rope, although some Technora® ropes have an aggressive grip.

Advantages

- ✓ High mechanical strength
- ✓ Low coefficient of friction
- ✓ Alignment of loads by textile crimping between rings
- ✓ Reliable and maintenance-free " No mechanical parts ".

References

BF 14-10	20273
BF 20-14	20274

Nodus Tips

Nodusfactory™ FRD rings have a higher workload compared to an equivalent pulley size and are easy to configure and install.



Parc d'Activités de Laroiseau • 5 rue Ella Maillart • F- 56000 Vannes
Tél : +33 (0)2 97 67 64 83 • Mail : sail@nodusfactory.com www.nodusfactory.com



Mickey-Ring® FrD - 3D violin pulley

« 3D violon ring adjustment - Dyneema® & Duralumin® »



Product Name	Breaking load	Ø Inside	recommended Ø		Sail area
			Halyard/sheet		
	Direct	Friction ring			40 kts
	kg	mm	mm		M2 ≥ 180°
BF M 14-10	1600/800	14/10	8/6		55
BF M 20-14	5000/3200	25/14	14/10		100

TECHNICAL SHEET

- FRD low-friction ring, in hardened anodized Duralumin → anthracite grey
- ✓ FrD10/FrD14
- ✓ FrD14/FrD20
- Textile® crimp between rings, core and sheath in 100% Dyneema® @.
- ✓ SK78 12 plaits pre-stretched, coated → Light grey / black
- Block® ring, in flexible TPE thermoplastic

- FRD ring
- ✓ Friction resistant with a good sliding coefficient under high load
- ✓ Improved rigidity
- ✓ Corrosion resistance
- ✓ Anthracite grey colour, orange marking

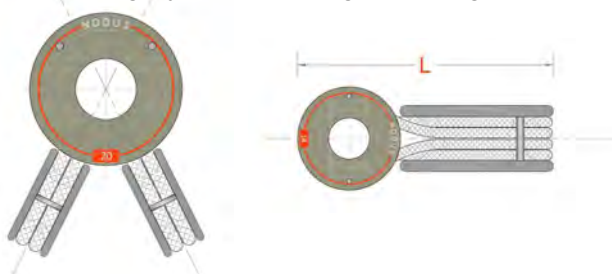

USE

- High load in static & dynamic use
- ✓ Under beard
- ✓ 3D headsail adjustment
- ✓ Downhaul
- ✓ Double sheets
- ✓ Deck plates & Hoist
- ✓ ... just about everything!

- The textile connection allows the load to self-align, reducing fatigue on rings and ropes.

Information sail@nodusfactory.com

NODUS
FACTORY

MADE IN FRANCE

www.nodusfactory.com



Scan me !

Mickey-Ring® FrD - 3D violin pulley

« 3D violon ring adjustment - Dyneema® & Duralumin® »



BF-M®, the 3D Mickey-ring violin block is a set of 3 connection points, ideal for efficiently adjusting your 3D genoa draft point.

- Lightweight and compact, the multiaxial 3D violin block allows perfect alignment of the connections at different angles. Each friction ring is adjustable and mobile (10 times lighter than a pulley), designed for heavy loads.
- Easy to configure, this 3D multiaxial system with friction rings rotating up to 180° will produce minimum friction and wear on your ropes.
- They can be used for just about anything and with any type of rope, although beware that some Technora® ropes have an aggressive grip.

Advantages

- High mechanical strength
- Low coefficient of friction
- Load alignment
- Large deflection angles

References

BF-M 14-10	
BF-M 20-14	20245

Nodus Tips

Nodus Factory FRD rings have a higher workload compared to an equivalent pulley size and are easy to configure and install.



Parc d'Activités de Laroiseau • 5 rue Ella Maillart • F- 56000 Vannes
Tél : +33 (0)2 97 67 64 83 • Mail : sail@nodusfactory.com www.nodusfactory.com



Nub® pulley - Low friction pulley

« High-load, multi-use, low-friction pulley »



Product name	Breaking Load	Weight	NUB Ø	Recommended rope Ø
	kg	gr	mm	mm
NUB® 40 HF	4700	26	40	8/10

TECHNICAL SHEET

- Nub® low friction pulley
- ✓ Technical polymer - Semi-crystalline thermoplastic
- ✓ Twice as light as aluminium and six times lighter than steel
- ✓ Friction resistance with a good sliding coefficient under high load
- ✓ Good chemical, mechanical and thermal resistance

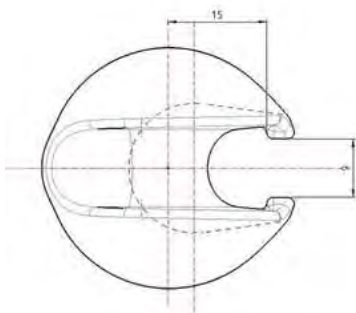

USE

- High load in Dynamic Use
- ✓ 3D headsail adjustment
- ✓ Backstay
- ✓ Downhaul
- ✓ Double sheets
- ✓ Deck plates & tackle
- ✓ ... just about everything!

- Combine the Nub® with our textile connectors:
- ✓ M or Ms shackle
- ✓ Loop or Lock®

Information sail@nodusfactory.com

NODUS
FACTORY

MADE IN FRANCE

www.nodusfactory.com



Scan me !

Nub© pulley - Low friction pulley

« High-load, multi-use, low-friction pulley »



The Nub® is a low-friction spherical pulley that withstands very high loads.

- ✓ Thanks to its intrinsic lubrication, it can be used in a wide range of applications and on all types of non-aggressive rope.
- ✓ Use our textile connectors to create your own pulley

Advantages

- ☐ High mechanical strength
- ☐ Low coefficient of friction

References

Nub 40	20122
---------------	--------------

Nodus Tips

- Choose the R-Nub® - Nub® reefing shackle for spinnaker sheets, as it is captive on the sheet and spinnaker arm.

NODUS
FACTORY
MADE IN FRANCE

Parc d'Activités de Laroiseau • 5 rue Ella Maillart • F- 56000 Vannes
Tél : +33 (0)2 97 67 64 83 • Mail : sail@nodusfactory.com www.nodusfactory.com



Spi 4Nub® - Spinnaker pulley on lashing strap

« Low-friction bushing pulley for high loads »



Product name	Breaking Load	Weight	Length	Sail area
			Straight	40 kts
	kg	gr	max cm	m2
Spi 4 Nub®	3500	66	50	130

To be used for bowsprit :

Bowsprit	Ø 70 mm	Ø 80 mm	Ø 90 mm**	Ø 100 mm**
Spi	60 m2	80 m2	100 m2	130 m2
Gennaker	37 m2	50 m2	65 m2	105 m2
Jib reefing *	1,5 t / 2,5 t	2,5 t / 4,5 t	4,5 t / 7,0 t	4,5 t / 7,0 t

* With jib-boom **Loop with lashing & Ring FrD

TECHNICAL SHEET

- Sewn webbing 100% Dyneema® SK78 48 plaits pre-stretched, coated ↪ black
- Structural eye termination ↪ sewn
- Lashing in Dyneema® SK78 - 12 plaits
- Low friction Nub® pulley ↪ Self-lubricated technical polymer resin ↪ black

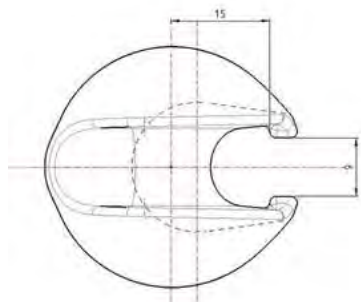

USE

- Spinnaker pulley for bowsprit with lashing strap attachment
- Tack position can be adjusted using the Nodus FR14 friction ring
- Adjustable strap length with Dyneema® lashing, fastened with a minimum of 4 half-hitch.

Information sail@nodusfactory.com

NODUS
FACTORY

MADE IN FRANCE

www.nodusfactory.com



Scan me !

Spi 4Nub® - Spinnaker pulley on lashing strap

« Low-friction bushing pulley for high loads »



The Spi 4Nub® is a Nub® pulley on a tie strap for attaching the spinnaker tack to the bowsprit.

✓ Adjustable attachment with lashing supplied in Dyneema®.

Advantages

- Easy to install, no mechanical fixings required " Anti-slip strip fitting optional
- Secure locking under and without load
- High mechanical strength
- Low coefficient of friction

References

Spi 4Nub	20122
-----------------	--------------

Nodus Tips

- Choose the R-Nub® shackle - Nub® reefing shackle, when reefing the spinnaker sheet as it is captive on the sheet and spinnaker arm..

NODUS
FACTORY
MADE IN FRANCE

Parc d'Activités de Laroiseau • 5 rue Ella Maillart • F- 56000 Vannes
Tél : +33 (0)2 97 67 64 83 • Mail : sail@nodusfactory.com www.nodusfactory.com



Pulleys & Snatch blocks



Pulleys & Nub®

Discover our I-Tech® ball pulleys and our Nodus Factory™ Nub® friction pulleys.



Key elements for boating, pulleys and rings make it possible to transmit forces, direct ropes, guide, or create tackles, essential accessories for rigging and adjusting sails.

Pulleys have evolved in recent years towards a new method of fixing that is more efficient than the stainless steel swivel shackle: lashing and the Dyneema® textile shackle.



Among the advantages of textile-fixed pulleys, we note that the forces pass directly through the center of the pulley “the sheave”, which improves its resistance and reduces the risk of breakage.

Advantages of textile-mounted pulleys:

1. Versatility of use thanks to its flexible fixing method
2. In the event of sheave breakage, the load is maintained by the lashing or textile shackle.
3. Pulley shape and design requires fewer parts
4. Lighter and stronger
5. No corrosion and no maintenance
6. Automatic load alignment



Nodus Factory hardware & Tips

Check that the lashing or textile shackle is attached to a trigger guard or chainplate whose edges are rounded.



Ball pulleys or textile hook friction!

- High performance, easy to use, lightweight designed for heavy loads.

A 4.0 fittings as a solution for controlling and returning a sheet under tension, which allows you to quickly pass a “Hooked” line in any situation: a genoa sheet, a spinnaker, etc.

The ideal solution for your barbers and in-haulers or as a replacement flying pulley on your sailboat.

They can be attached anywhere on the deck, and another advantage is that the Nodus Factory Hook® sntach block can be opened with just one hand.

Opening and closing our low-friction “Hook®” carabiner type opening pulleys prevents the rope from coming out, the action is done quickly and securely thanks to the Velcro® strap.

Made of POM or I Tech® Polymer and hardened anodized aluminum and supplied with our Dyneema® textile connectors (TH-C spliced textile shackle or TH-M spliced textile shackle).

Nodus Factory hardware & Tips

- The Nodus Factory Hook® is a versatile product for hooking everywhere: tack, mast base, barber etc.

Pulley Hi-Tech® - Ball-bearing pulley

« Sustainable, ultra-light Hi-Tech pulley »



Product Name	Breaking load	weight	Length	rope Ø
	Direct		L	Halyard/sheet
PA Tech	kg	gr	cm	mm
P 20	400	2	4	4/6
P 30	500	4	5	6/8
P 40	700	7	5	8/10

TECHNICAL SHEET

High-strength, ultra-light Hi-tech pulley

- ✓ Composite pulley body
 - ✓ Moulded HD Polymer flanges
 - ✓ I-Tech & PA 6.6 composite sheave
 - ✓ Dynamic ball bearing
 - ✓ Double row of 316 stainless steel balls
-
- Dyneema® textile connector
 - ✓ SK78 12 plaits, coated and pre-stretched
 - T-close® connector → Pa Tech glass-fiber filled



USE

The Hi-tech® Nodus pulley allows you to multiply forces and redirect a manoeuvre, a halyard or a sheet, or move a load in a different direction.

- Returns, hoist, barber, cascade, etc.

Designed to support two types of load :

- ✓ static load
- ✓ dynamic load

Information sail@nodusfactory.com

NODUS
FACTORY

MADE IN FRANCE

www.nodusfactory.com



Scan me !

Pulley Hi-Tech® - Ball-bearing pulley

« Sustainable, ultra-light Hi-Tech pulley »



Hi-Tech P® pulleys, High-strength, ultra-light, Hi-tech single-transfer pulleys. Compact in shape, they are designed for high working loads. Loads are carried directly from the sheaves to the attachment point, using lightweight side plates. Designed primarily for racing, they can be used in almost any situation...

➤ Attached by shackle, loop or lashing in Dyneema® ©.

Our pulleys are among the toughest on the market!

Advantages

- Weight-to-strength ratio
- Performance, lightness and reliability
- Low coefficient of friction
- Load alignment via textile connector

References

Poulie Hi-Tech 20	20364
Poulie Hi-Tech 30	20365
Poulie Hi-Tech 40	20366

Nodus Tips

- Accessorize your Hi-Tech Nodus pulleys with our Dyneema® hooks and connectors.
- ✓ Loop
- ✓ T shackle



Parc d'Activités de Laroiseau • 5 rue Ella Maillart • F- 56000 Vannes
Tél : +33 (0)2 97 67 64 83 • Mail : sail@nodusfactory.com www.nodusfactory.com



Double pulley Hi-Tech®

Heavy-duty, ultra-light double Hi-Tech pulley



Product Name	Breaking Load	Weight	Length under pulley	Recommended rope Ø
Double pulley	Direct		L	Rope
PA Tech	kg	gr	cm	mm
P 20.2	600	5	5	4
P 30.2	750	9	8	6
P 40.2	900	15	11	8

TECHNICAL SHEET

High-strength, ultra-light double Hi-tech pulley

- ✓ Composite pulley body
- ✓ Moulded HD Polymer flanges
- ✓ I-Tech & PA 6.6 composite sheave
- ✓ Dynamic ball bearing
- ✓ Double row of 316 stainless steel balls

Dyneema® textile connector

- ✓ DSK78 12 plaits, coated, pre-stretched
- ✓ T-close® connector → Pa Tech glass-fiber reinforced

USE

The Hi-tech® Nodus double pulley allows you to multiply your efforts and redirect a manoeuvre, a halyard or a sheet, or move a load in a different direction.

- Returns, hoist, barber, cascade, etc.

Designed to support two types of load :

- ✓ static load
- ✓ dynamic load

Information sail@nodusfactory.com

NODUS
FACTORY
MADE IN FRANCE
www.nodusfactory.com



Scan me !

Double pulley Hi-Tech®

Heavy-duty, ultra-light double Hi-Tech pulley



Hi-Tech P2® Nodus® double pulley, High-strength and ultra-lightweight Hi-tech double pulley with transfer, compact design for high working loads.

Loads are carried directly from the sheaves to the attachment point, using lightweight side plates. Designed primarily for racing, they can be used in almost any situation...

Attached by shackle, loop or lashing in Dyneema®.

Our pulleys are among the toughest on the market!

Advantages

- Weight-to-strength ratio
- Performance, lightness and reliability
- Low coefficient of friction
- Load alignment via textile connector

References

Poulie Hi-Tech 20.2	20240
Poulie Hi-Tech 30.2	20241
Poulie Hi-Tech 40.2	20242

Nodus Tips

- Accessorize your Hi-Tech® Nodus double pulleys with our Dyneema® hooks® and connectors.
- ✓ Loop
- ✓ T shackle



Parc d'Activités de Laroiseau • 5 rue Ella Maillart • F- 56000 Vannes
Tél : +33 (0)2 97 67 64 83 • Mail : sail@nodusfactory.com www.nodusfactory.com



Opening pulley Hi-Tech® - Dyneema® shackle

« Sustainable, ultra-light Hi-Tech opening pulley »



Product Name	Breaking Load	Weight	Length under pulley	Recommended rope Ø	Sail area
Connector	Direct		L	Halyard/Sheet	40 kts
PA Tech	kg	gr	cm	mm	M2 ≥45°
PO 20*	400	2	5,5	max 4	8
PO 30*	500	4	7	max 6	12
PO 40*	700	7	7	max 8	14

TECHNICAL

High-strength, ultra-light Hi-tech snatch block

- ✓ Composite pulley body
- ✓ Moulded swivel flanges in HD Polymer
- ✓ I-Tech & PA 6.6 composite sheave
- ✓ Dynamic ball bearing
- ✓ Double row of 316 stainless steel balls

Dyneema® textile connector

- ✓ DSK78 12 plaits, coated and pre-stretched
- ✓ T-close® connector → Pa Tech glass-fiber reinforced

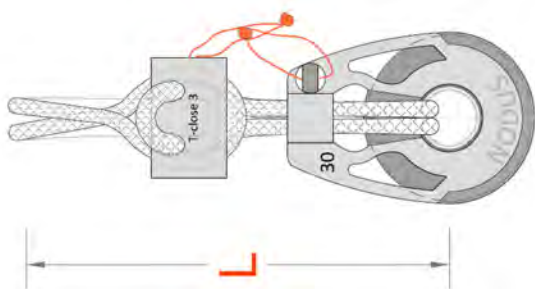

USE

The Hi-tech® Nodus opening pulley :

- ✓ Controls and returns sheets under tension
- ✓ Allows a rope to be passed through quickly in any situation
- ✓ Allows you to redirect a manoeuvre, a halyard or a sheet, or move a load in a different direction.

Designed to withstand two types of load :

- ✓ static load
- ✓ dynamic load

Information : sail@nodusfactory.com

NODUS
FACTORY

MADE IN FRANCE

www.nodusfactory.com



Scan me !

Opening pulley Hi-Tech® - Dyneema® shackle®

« Sustainable, ultra-light Hi-Tech opening pulley »



PO® opening pulley, supplied with a Dyneema® T shackle. Ultra-light and compact, they are designed for high working loads. Loads are led directly from the sheaves to the attachment point, allowing light side swivel cheeks. Designed primarily for racing, they can be used in almost any situation...

➤ Dyneema® © T shackle attachment

Our pulleys are among the toughest on the market!

Advantages

- Weight-to-strength ratio
- Performance, lightness and reliability
- Secure opening and closing
- Low coefficient of friction
- Textile connector aligns loads

References

Opening pulley Hi-Tech 20	20367
Opening pulley Hi-Tech 30	20368
Opening pulley Hi-Tech 40	20369



Parc d'Activités de Laroiseau • 5 rue Ella Maillart • F- 56000 Vannes
Tél : +33 (0)2 97 67 64 83 • Mail : sail@nodusfactory.com www.nodusfactory.com



Pp Hi-Tech® - Traveler Pulley

« Lightweight, resistant traveller pulley »



Product Name	Breaking Load	Weight	Length L	Recommended rope Ø		Sail area
				Pulley	Ring	
Connector	Direct			mm	mm	40 kts
	kg	gr	cm			M2 ≥45°
PP 30	500	25	4,5	4/6	4/8	12
PP 40	700	28	6,5	6/8	6/10	14

TECHNICAL SHEET

- Friction ring D → Hard anodized Duralumin ring
→ Anthracite grey
- ✓ High-strength, ultra-light Hi-tech pulley
- ✓ Composite pulley body
- ✓ Moulded flanges in HD Polymer
- ✓ I-Tech & PA 6.6 composite sheave
- Dynamic ball bearing
- ✓ Double row of 316 stainless steel balls

- Dyneema® textile loop connector
- DSK78 12 plaits, coated and pre-stretched
- Block® ring, clamping and retaining ring, in flexible TPE thermoplastic.

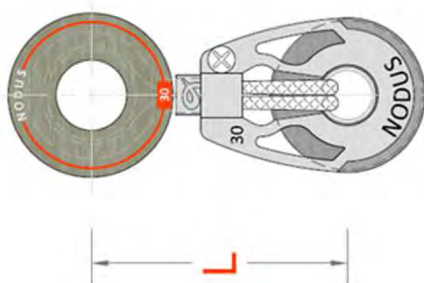

USE

- The PP Hi-Tech pulley with FRD low friction ring is the lightest violin block designed for pantor pulleys or jib tackers on textile tracks,
- ✓ Barber Hauler
- ✓ Returns ,
- ✓ 3D adjustment,
- ✓ Dinghy Pants...
- ✓ For Mainsail hoist on textile pantoire

Information sail@nodusfactory.com

NODUS
FACTORY

MADE IN FRANCE

www.nodusfactory.com



Scan me !

Pp Hi-Tech® - Traveler Pulley

« Lightweight, resistant traveller pulley »



PP®, the lightest and strongest pulley on the market.

- The small sheave of the friction ring slides over the crew's foot and the ball bearing block is used for the passage of the hoist sheet.

Our pulleys are among the strongest on the market!

Advantages

- Weight-to-strength ratio
- Performance, lightness and reliability
- Low coefficient of friction
- Load alignment via textile connector

References

PP Hi-Tech 30	20341
PP Hi-Tech 40	20361



Parc d'Activités de Laroiseau • 5 rue Ella Maillart • F- 56000 Vannes
Tél : +33 (0)2 97 67 64 83 • Mail : sail@nodusfactory.com www.nodusfactory.com



Textile-Hook® - Friction opening pulley

« Textile hook Opening friction ring »



Product Name	Breaking load	Weight	Length L	recommended rope Ø	Sail area
Use	Direct			Halyard/Sheet	25 kts
Static	Kg	gr	cm	mm	M2 ≥45°
TH-C 14s	800	12	5	6/10	45/75
TH-C 20s	2000	24	7	10/14	70/110
TH-M 14s	2500	20	5	6/10	80/110
TH-M 20s	3000	34	7	10/14	110/150
Dynamic	Kg	gr	cm		
TH-C 14 I-tech	400	10	5	6/10	25/40
TH-C 20 I-tech	1200	24	7	10/14	80/110

TECHNICAL SHEET

High-strength open low-friction ring

- ❑ Open ring hook body
 - Hook S self-lubricating thermoplastic material
 - ✓ POM / use Static, low friction T°C continuous use 100° T°C
 - Hook I-tech self-lubricating HD polymer
 - ✓ Po iTech / use Dynamic, very high friction speed Continuous operating temperature T °C +140 /180
- ❑ Dyneema® textile connector
 - ✓ DSK78 12 plaits, coated and pre-stretched
 - ✓ T-close® connector ↪ Pa Tech glass-fiber reinforced
 - ✓ T-Bone® connector ↪ Anodized and hard anodized aluminium

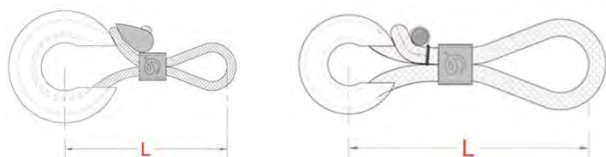

USE

The Textile-Hook® friction opening pulley

- ✓ Controls and returns sheets under tension
- ✓ Allows a rope to be passed through quickly in any situation
- ✓ Allows you to redirect a manoeuvre, a halyard or a sheet, or move a load in a different direction.

Designed to support two types of load:

- ✓ static load - Hook s
- ✓ dynamic load - Hook I-tech

Information sail@nodusfactory.com

NODUS
FACTORY

MADE IN FRANCE

www.nodusfactory.com



Scan me !

Textile-Hook® - Friction opening pulley

« Textile hook Opening friction ring »



TH-C® & TH-M®, the Textile Hook® friction opening block is the lightest and strongest sheet control solution on the market,

- This open ring is easy to position on the rope and its textile attachment system prevents it from opening under load.
- For dynamic use, use I-Tech resin rings or the HK16 in duralumin.
- Dyneema® © shackle attachment / connection

Our Textile-hooks® are among the toughest available on the market!

Advantages

- Weight-to-strength ratio
- Performance, lightness and reliability
- Low coefficient of friction
- Load alignment via textile connector

References

TH-Cs 14	20118
TH-Cs 20	20119
TH-Ms 14	20120
TH-Ms 20	20121
TH-C I-tech 14	20221
Th-C I-tech 20	20222

Nodus Tips « FAQ - Material information »

Material	Durability / Wear	Friction	T° use	T° Celsius	Dynamic	Static	Material price
ITECH	5/5	5/5	4/5	+ 140° / 180°	5/5	4/5	5/5
ALUMINIUM	4/5	4/5	5/5	+ 180° / 240°	4/5	5/5	4/5
PEEK	4/5	3/5	4/5	+ 140° / 180°	4/5	5/5	3/5
POM	3/5	4/5	2/5	100°	3/5	3/5	2/5



Parc d'Activités de Laroiseau • 5 rue Ella Maillart • F- 56000 Vannes
Tél : +33 (0)2 97 67 64 83 • Mail : sail@nodusfactory.com www.nodusfactory.com



Textile Hook Nub® - opening pulley

« Opening friction pulley »



Product Name	Breaking Load	Weight	Length	Recommended rope Ø	Sail area
Static	Direct			Rope	40 kts
Friction	Kg	gr	cm	mm	M2 ≥45°
TH-NUB Simple	4 700	40	10	8 / 10	170
TH-NUB Double	4 700	72	12	8 / 10	170

TECHNICAL SHEET

- Nodus-Nub® open low-friction ring
 - ✓ Black thermoplastic resin
- Sheathed or over-sheathed textile connector
 - ✓ 100% Dyneema® SK78 12 plaits pre-stretched grey
- T-bone (dog bone) anodized aluminium 7075
 - ✓ Treated, hardened light grey,
- Secure Velcro fastening by winding over the textile connector
 - ✓ Twist-lock

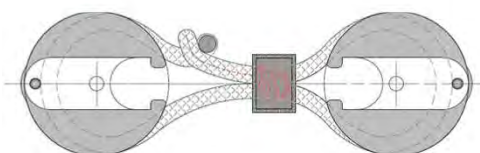
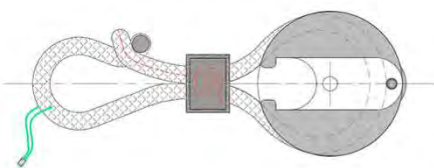

USE

- Controls and returns of genoa or spinnaker sheets under tension.
- Allows you to Hook a loaded rope quickly, Barber inhauler, furler, 3D, ...

Information sail@nodusfactory.com

NODUS
FACTORY

MADE IN FRANCE

www.nodusfactory.com



Scan me !

Textile Hook Nub® - opening pulley

« Opening friction pulley »



T-H Nub®, Low friction open spherical ring type hook for 12 mm rope.

An open friction block that can easily be hooked to a genoa or spinnaker sheet or as a replacement for a block at the foot of the mast.

Use

- Controls and returns genoa or spinnaker sheets under tension.
- Allows you to Hook a loaded rope quickly, Barber in-hauler, furler, 3D, ...

Advantages

- Weight-to-strength ratio
- Lightweight and reliable
- Twist-Lock carabiner lock prevents the sheet from popping out

References

TH-NUB Simple	20187
TH-NUB Double	20186



Parc d'Activités de Laroiseau • 5 rue Ella Maillart • F- 56000 Vannes
Tél : +33 (0)2 97 67 64 83 • Mail : sail@nodusfactory.com www.nodusfactory.com



Textile-Hook® Hk - opening friction pulley

« Opening friction ring textile-Hook »



Product Name	Breaking Load	Weight	Length L	Recommended rope Ø	Sail area
Connector	Direct			Halyard/Sheet	40 kts
Aluminum	Kg	gr	cm	mm	M2 ≥45°
HK16	6 000	120	8	max 16mm	160
HK22	8 500	270	custom	max 22mm	>160
HK32	12 000	350	custom	max 32mm	>160

TECHNICAL SHEET

High-strength open low-friction ring

- Open ring hook body
- HK Duralumin material
- ✓ Anodized and hardened
- Dyneema® high load M® overbraided shackle
- ✓ DSK78 12 plaits, coated and pre-stretched
- ✓ Oversheath 48 plaits, coated and pre-stretched
→ Black
- ✓ T-bone® connector, hard anodized aluminium, for opening and closing the textile shackle
- Twist-Lock® accessory
- ✓ Velcro® Polypropylene & Velvet PA

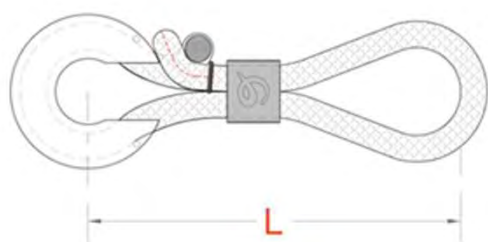

USE

The Textile-Hook® friction opening pulley

- ✓ Controls and returns sheets under tension
- ✓ Allows a rope to be passed through quickly in any situation
- ✓ Allows you to redirect a manoeuvre, a halyard or a sheet, or move a load in a different direction.

Designed to withstand heavy loads:

- ✓ permanent static load
- ✓ dynamic load for any rope

Information sail@nodusfactory.com

NODUS
FACTORY

MADE IN FRANCE

www.nodusfactory.com



Scan me !

Textile-Hook® Hk - Opening friction pulley

« Opening friction ring textile-Hook »



Textile-Hook HK® in duralumin is the lightest and strongest sheet control solution on the market,

- This open ring is easy to position on the rope, and its textile fastening system with double security prevents it from opening under or without load.
- For static & dynamic high load use
- Attached / connected by Dyneema® © shackle
- Nub® accessory to create a heavy-duty hoist

Our Textile-hooks® are among the toughest on the market!

Advantages

- Weight-to-strength ratio
- Performance, lightness and reliability
- Low coefficient of friction
- Load alignment via textile connector

References

Textile-Hook HK 16

20182

Nodus Tips « FAQ - Material information »

Material	Durability / Wear	Friction	T° use	T° Celsius	Dynamic	Static	Material price
ITECH	5/5	5/5	4/5	+ 140° / 180°	5/5	4/5	5/5
ALUMINIUM	4/5	4/5	5/5	+ 180° / 240°	4/5	5/5	4/5
PEEK	4/5	3/5	4/5	+ 140° / 180°	4/5	5/5	3/5
POM	3/5	4/5	2/5	100°	3/5	3/5	2/5

NODUS
FACTORY
MADE IN FRANCE

Parc d'Activités de Laroiseau • 5 rue Ella Maillart • F- 56000 Vannes
Tél : +33 (0)2 97 67 64 83 • Mail : sail@nodusfactory.com www.nodusfactory.com



Fairleads & Textile Padeyes®



Fairleads & textile padeyes to be stick

Discover our range of stick-on padeyes, trigger guards and threaders, they advantageously replace traditional stainless steel padeyes and trigger guards.



They benefit from an excellent strength/weight ratio and good abrasion resistance thanks to Dyneema®.

Our stick-on padeyes have many advantages, lightness, resistance and are easy to install.



Equipped with a low friction ring, pulley and textile link, they allow you to create your bridge plans according to your desires and needs.

You will find that Sx textile Padeyes (adjustable Dyneema® loop), Pad-Race, Pad-Hook, Pad-Pulley, Pad-Line or even the Pad-FrD), are available in several sizes and in different models.



Our range of glue-on accessories and equipment is the lightest and strongest solution on the market.

This range allows you many applications to equip your sailboat. Easy and quick to install thanks to our two-component Nodus-Loc glue, their installations do not require drilling in your sailboat.

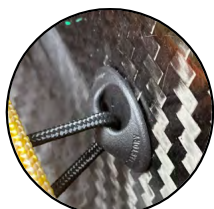

When and how to use Nodus-Loc®?

“Padeyes, threaders and glue-on fairleads”

The advantages of methacrylate structural glues

Methacrylate glues have the advantage of reduced surface preparation, sometimes simple dust removal where degreasing is sufficient. Methacrylate glues are very resistant to vibrations, shocks and climatic conditions. Immersion bonding is possible.

- ✓ Methacrylate glues do not need a primer, whatever the support.
- ✓ Rapid crosslinking to reduce the production cycle.
- ✓ Bonding of heterogeneous materials
- ✓ Very high resistance to shearing, impact, peeling and fatigue
- ✓ Good chemical resistance to hydrocarbons, acids and bases (pH 3 to 10) and saline solutions
- ✓ The formulation is classified neither toxic nor carcinogenic (absence of DNPT, Dimethylaniline and phthalates)
- ✓ Ease of implementation

Compare the bonding resistance of Nodus-Loc®

- Multi-purpose marine adhesive-putty 1.8 MPa
Type Sikaflex® -291i Or 18.55 Kg/cm²
- Structural methacrylate glue 12 to 24 MPa
Nodus-Loc® i.e. 122.36 Kg/cm² to 244.73 Kg/cm² (depending on support)

Comparing with Sikaflex® -291i multi-purpose marine putty glue, you will be 10 times less resistant than our Nodus-Loc glue.



Pad-SX[®] - textile Padeye to stick

Adjustable (r) or fixed (f) textile length



Product Name	Resistance	Weight	Dimensions mm				Length
			A	B	C	D	
	kg	gr					cm
Pad SX 45	200 kg	12	3	35	45	6	30
Pad SXc 45	200 kg	12	3	35	45	6	2,5
Pad SX 55	350 kg	14	3,5	42	55	8	30
Pad SXc 55	350 kg	14	3,5	42	55	8	2,5

Option - glue	Volume	Quantity	Supports
Nodus-Loc[®] 12	12 ml	6 padeyes	multiple

TECHNICAL SHEET

Padeye SX[®] - Textile trigger guard & lashing

- ✓ Padeye SX 45 & 55 in glass-filled technical PA
- ✓ T-Bone Ti6 eco-titanium length 20mm & length 25mm
- ✓ Textile Dyneema[®] 12 plaits diameter 3 mm or 4 mm
- ✓ 316 L stainless steel screws: 2.9 mm / 18 mm (not supplied)
- ✓ Nodus-Loc Bi-component adhesive (optional)

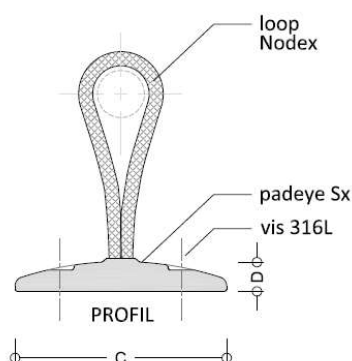

MOUNTING

- 1- Prepare and clean the surface.
- 2- Mix and apply the two-component adhesive.
- 3- Glue and maintain pressure for at least 5'.

➤ Wait 24 hours before use

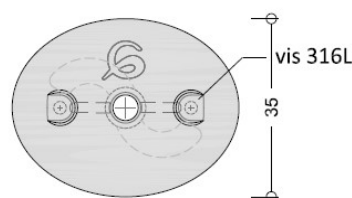

Information sail@nodusfactory.com

NØDUS
FACTORY
MADE IN FRANCE
www.nodusfactory.com



Pad-SX[®] - Padeye textile to stick

Adjustable (r) or fixed (f) textile length

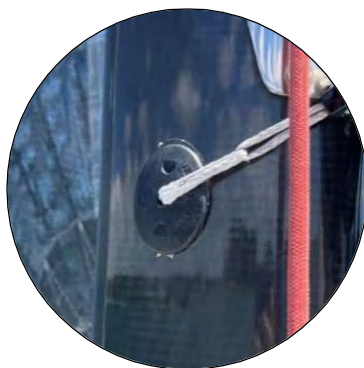

The **Pad-SX[®]** is a glue-on resin textile bridge designed and developed by Nodus Factory to meet specific on-board requirements.

- Quick and easy to install, your Pad-SX will support from 200 kg to 350 kg once fixed with Nodus-Loc[®] bi-component adhesive.
- The length of the textile bridge is adjustable for the (R) model before gluing and fixed for the (F) model.
- Its oval shape allows the pad-eye to be positioned optimally depending on the angle and direction of the load.

Use

Multi-purpose textile cable tie for hanging or hooking all your equipment in or on your boat, sunbeds, canvas covers, stowage pockets, light manoeuvring transmissions, etc.

Easy to fit and stick anywhere on deck, below deck, on the mast or boom, etc.

Advantages

- Easy to install, thanks to our bi-component adhesive
- Length of textile strands can be adjusted to suit your needs
- Versatility and flexibility, whatever the angle of pull
- Creation of new fixed points
- Optimises ergonomics, no protruding or aggressive parts
- Improves your deck plans

References

Pad-SX 45r	Adjustable textile	20132
Pad-SX 55r	Adjustable textile	20197
Pad-SX 45f	Fixed textile	20216
Pad-SX 55f	Fixed textile	20223



Parc d'Activités de Laroiseau • 5 rue Ella Maillart • F- 56000 Vannes
Tél : +33 (0)2 97 67 64 83 • Mail : sail@nodusfactory.com www.nodusfactory.com



Pad-Filoir® D - Fairlead friction ring

« Fairlead on padeye SX to stick »



Product Name	Breaking load			Dimension Ø				Recommended line Ø	Weight
	0°	90°	180°	A	B	C	D		
Duralumin D	kg	kg	kg	mm				mm	gr
Pad-Filoir 10	1500	950	500	7	12	12	30	4/8	8
Pad-Filoir 14	1800	1100	650	10	16	16	40	6/10	16

Option - glue	Volume	Quantity	Supports
Nodus-Loc® 12	12 ml	6 padeyes	multiple

TECHNICAL SHEET

Support base to be glued

- Padeye SX® in glass-fiber reinforced technical PA
 - ✓ Length 45 mm & Width 35 mm
 - ✓ Textile Dyneema® webbing
 - ✓ T-Bone Ti6 eco-titanium
 - ✓ SK78 48x coated light grey
- Aluminium spinner for sheet guide and furling line
 - Max 4 to 10 mm
 - ✓ FrD® friction ring in hard anodized duralumin
- Fixing by glue or screw (optional) :
 - ✓ 2 Ø 5 mm holes

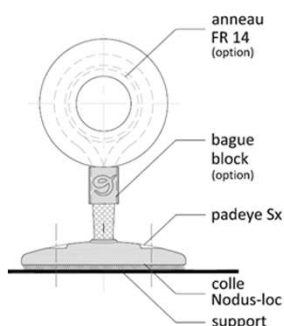

MOUNTING

- 1- Prepare and clean the surface.
 - 2- Mix and apply the two-component adhesive.
 - 3- Glue and maintain pressure for at least 5'.
- Wait 24 hours before use

Information sail@nodusfactory.com

NODUS
FACTORY

MADE IN FRANCE

www.nodusfactory.com



Scan me !

Pad-Filoir®D - Fairlead friction ring

« Fairlead on padeye SX to stick »



Pad-filoir D®, self-aligning sheet wire.

Its design, with its textile axis, automatically aligns your sheet for minimum friction.

- Very easy to install, your Pad-Filoir®D will support up to 200 kg (without screws) once fixed with Nodus-Loc® bi-component adhesive.
- The oval shape of its "Padeye SX" support means that the spinner can be installed at the optimum angle and in the direction of the load.
- Essential when installing a headsail furler, the flexibility of the fabric automatically steers your sheets and ropes sideways and at an angle.

Use

- Clew lines, furling lines, turnbuckles, deck plan improvement, etc.
- For sheets and lines from 4 mm to 10 mm maximum

Advantages

- Automatic alignment
- To be glued or screwed with our Bi-component adhesive

Reference

Pad-Filoir D 10	20282
Pad-Filoir D 14	20283

Nodus Tips

- D® low-friction spinners have a non-adhesive surface due to their design and the material used. Friction is dynamic without loss of energy.
- The contact surface and automatic alignment create a low angle of friction that limits adhesion at the start of the manoeuvre and improves sliding performance.



Parc d'Activités de Laroiseau • 5 rue Ella Maillart • F- 56000 Vannes
Tél : +33 (0)2 97 67 64 83 • Mail : sail@nodusfactory.com www.nodusfactory.com



Pad-Pulley® I-Tech - Fairlead with Block

« Fairlead on adhesive SX padeye »



Product Name	Pulley I-Tech	Padeye	Breaking load	Ø Rope	Weight
			Direct	Halyard / Sheet	
PA Tech			kg	mm	gr
Pad-P 20	20	Pad SX-45	200	4	15
Pad-P 30	30	Pad SX-45	200	6	16
Pad-P 40	40	Pad SX-55	300	8	24

Option - glue	Volume	Quantity	Supports
Nodus-Loc® 12	12 ml	6 padeyes	multiples

TECHNICAL SHEET

- base Support to be glued
- ✓ Padeye SX® in glass-fiber reinforced technical PA
- ✓ Length 45 mm & Width 35 mm
- ✓ Textile Dyneema® webbing
- ✓ T-Bone Ti6 eco-titanium
- ✓ SK78 48x coated light grey

- I-Tech® pulley block fairlead for sheet guide and furling line Max 4 to 10 mm
- ✓ Composite block body
- ✓ Stainless steel ball bearing
- ✓ Composite sheave PA 6.6

- Attachment by glue or screw (optional) :
- ✓ 2 Ø 5mm holes

MOUNTING

- 1- Prepare and clean the surface.
- 2- Mix and apply the two-component adhesive.
- 3- Glue and maintain pressure for at least 5'.

➤ Wait 24 hours before use

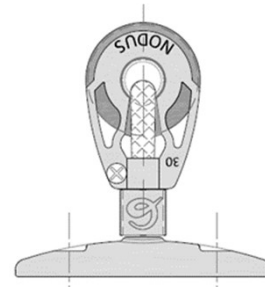

Information sail@nodusfactory.com

NODUS
FACTORY
MADE IN FRANCE
www.nodusfactory.com



Scan me !

Pad-Pulley® I-Tech - Fairlead with Block

« Fairlead on adhesive SX padeye »



Pad-Poulie I-Tech®, self-aligning ball-pulley sheet fairlead.

Its design, with its textile shaft, automatically aligns your sheet to minimize friction.

Lightweight and extremely efficient, they are ideal for frequently used tuning systems.

Very easy to install, your I-tech® Pad-Pulley will support from 200 kg to 300 kg (without screws) once fixed with Nodus-Loc® bi-component glue.

For halyard and sheeting systems and other applications where you don't want the block to touch the deck. Essential when installing a headsail furler, the flexibility of the fabric automatically steers your sheets and ropes sideways and at an angle.

Use

- Clew lines, furling lines, turnbuckles, deck plan improvement, etc.
- For sheets and lines from 4 mm to 10 mm maximum

Advantages

- Automatic alignment
- To be glued or screwed with our Bi-component adhesive

References

Pad-P20	20134
Pad-P30	20135
Pad-P40	20260

Nodus Tips

- Automatic alignment creates a low angle of friction that limits grip at the start of the manoeuvre and improves sliding performance.

NODUS
FACTORY
MADE IN FRANCE

Parc d'Activités de Laroiseau • 5 rue Ella Maillart • F- 56000 Vannes
Tél : +33 (0)2 97 67 64 83 • Mail : sail@nodusfactory.com www.nodusfactory.com



Pad-Line® - Adjustable cleat for rope storage

« Adjustable length »

Product Name	Load (glued)	Weight	Pad Dimension (mm)				Rope Length
			A	B	C	D	
	kg	gr					Cm
Pad-line	250 kg	15	3	35	45	6	30

Option - glue	Volume	Quantity	Supports
Nodus-Loc® 12	12 ml	6 padeyes	multiples

TECHNICAL SHEET

Padeye Pad-Line® - Textile cleat and lashing

- ✓ Padeye SX 45 in glass-fiber reinforced technical PA
- ✓ T-Bone TI6 eco-titanium
- ✓ T-close connector in technical PA
- ✓ Textile Dyneema® 12 plaits diameter 3 mm
- ✓ 316 L stainless steel screws: 2.9 mm / 18 mm (not supplied)
- ✓ Nodus-Loc Bi-component adhesive (optional)

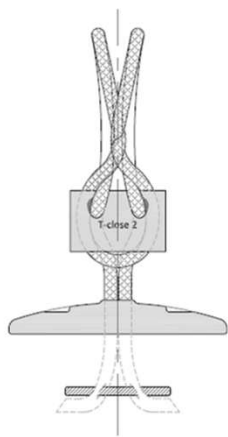

MOUNTING

- 1- Prepare and clean the surface.
- 2- Mix and apply the two-component adhesive.
- 3- Glue and maintain pressure for at least 5'.

➤ Wait 24 hours before use

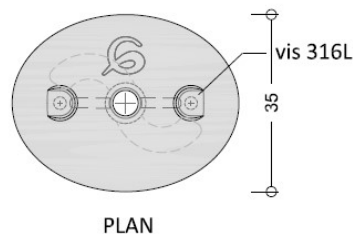

Information sail@nodusfactory.com

NODUS
FACTORY
MADE IN FRANCE
www.nodusfactory.com



Scan me !

Pad-Line® - Adjustable cleat for rope storage

« Adjustable length »



Pad-line®, a textile rope storage cleat that can be screwed on or glued on, is the ideal solution for storing your ropes and sheets once you're on board.

- Very easy to install, your Pad-line® cleat allows you to clear the cockpit of your various ropes and sheets while keeping them neatly coiled and ready for immediate use.

Use

- The Pad-line cleat, once fixed to the wall, keeps your ropes well coiled thanks to a toggle.
- Easy to fit and stick anywhere on deck, below deck or on the mast

Advantages

- Ideal storage for halyards and sheets
- Easy to install, thanks to our bi-component adhesive
- The length of the textile strands can be adjusted to suit your needs
- No protruding or aggressive parts

References

Pad-Line	20136
----------	-------

Nodus Tips

- Tie the line correctly and pass the string through the skein, then attach the string to the T-close connector.
- Ideal for hanging halyards in the cockpit when leaving the clam cleats!

NODUS
FACTORY
MADE IN FRANCE

Parc d'Activités de Laroiseau • 5 rue Ella Maillart • F- 56000 Vannes
Tél : +33 (0)2 97 67 64 83 • Mail : sail@nodusfactory.com www.nodusfactory.com



Pad-RACE® - « Padeye » Chainplate to stick



Product Name	Glue resistance		Weight		Pad dimensions (mm)		
	kg	gr	H	L	I		
Pad Race 45	200 kg	6	10	45	35		
Pad Race 55	350 kg	8	12	55	40		

Option - glue	Volume	Quantity	Supports
Nodus-Loc® 12	12 ml	6 padeyes	multiples

TECHNICAL SHEET

Pad-Race® - Chainplate & textile lashing

- Pad-Race available in bio-sourced PA11 or PA12
- ✓ Length 45 mm - Width 35 mm - Height 10 mm
- ✓ Length 55 mm - Width 42 mm - Height 12 mm
- Nodus-Loc Bi-component glue (not supplied)
- LOOP webbing in 48 plaits Dyneema®, sewn splice



MOUNTING

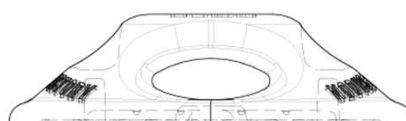

- 1- Prepare and clean the surface.
- 2- Mix and apply the two-component adhesive.
- 3- Glue and maintain pressure for at least 5'.

➤ Wait 24 hours before use

Information sail@nodusfactory.com

NODUS
FACTORY
MADE IN FRANCE
www.nodusfactory.com



Scan me !

Pad-RACE® - « Padeye » Chainplate to stick



The Pad-Race® is a resin padlock designed and developed by Nodus Factory™ in collaboration with Team Paprec-Arkea to meet specific onboard requirements.

- Quick and easy to install, your Pad-Race will support between 200 kg and 350 kg once fixed with Nodus-Loc® bi-component glue.
- Its oval shape means that the pad-eye can be installed at the optimum angle and in the direction of the load.

Use

- Multi-purpose textile chainplate for light manoeuvres
- Easy to fit and stick anywhere on deck, below deck, on the mast or boom,...

Advantages

- Creation of new fixed points
- Quick and easy to install, thanks to our bi-component adhesive
- Optimized ergonomics, with no protruding or aggressive parts
- Versatility and flexibility, whatever the angle of pull
- Improves your deck plans

References

Pad-Race 45	20169
Pad-Race 55	20166



Parc d'Activités de Laroiseau • 5 rue Ella Maillart • F- 56000 Vannes
Tél : +33 (0)2 97 67 64 83 • Mail : sail@nodusfactory.com www.nodusfactory.com



Pad-FILOIR® - Fairlead for halyard and rope

« adhesive Mast fairlead I-Tech »



Product Name	Glue resistance	Weight	Pad dimensions (mm)	
	kg	gr	Diameter	Height
Fairlead-Pad	250 kg	11,4	24	24
Option - glue	Volume	Quantity	Supports	
Nodus-Loc® 12	12 ml	6 padeyes	multiples	

TECHNICAL SHEET

I-Tech resin glue line for Max 10/12 mm halyard leads, sheets and furling lines

Base :

- ✓ Diameter 40
- ✓ Height 24 mm
- ✓ Thickness 6 mm
- ✓ Weight: 11.4 grams

Fixing by glue or screws (screws not supplied) :

- ✓ 2 Ø 5 mm holes

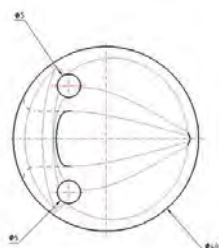

MOUNTING

- 1- Prepare and clean the surface.
- 2- Mix and apply the two-component adhesive.
- 3- Glue and maintain pressure for at least 5'.

Wait 24 hours before use

Information sail@nodusfactory.com

NODUS
FACTORY

MADE IN FRANCE

www.nodusfactory.com



Scan me !

Pad-FILOIR® - Fairlead for halyard and line

« adhesive Mast fairlead I-Tech »

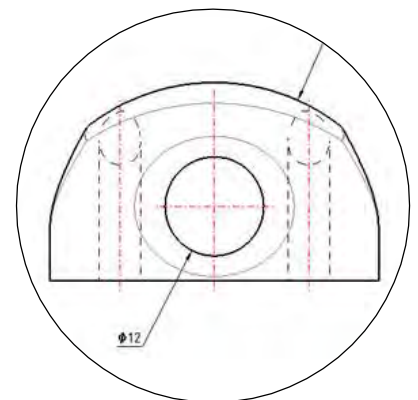

The glue-on furling line and spinnaker halyard pad is specifically designed to be glued to a mast, boom or deck for a sheet or furling line.

- Essential for the installation of a headsail furler or spinnaker halyard, the designed shape of the line allows a lateral deviation of + 30° (left or right).

Use

- Mast, boom, spinnaker halyard, clew line, furling line, pulleys, deck layout improvement
- The Pad-Filoir®, once glued to the wall, mast or boom, guides your ropes and halyards
- Ø halyard or line 10 mm max : 12 mm

Advantages

- Stick or screw with our two-component glue
- Simple and easy to use

Reference

Pad-Filoir	20188
-------------------	--------------

Nodus Tips

- I-Tech® low-friction fairleads have a non-adhesive surface due to their design and the material used. Friction is dynamic without loss of energy.
- The contact surface creates an angle of friction that limits adhesion at the start of the manoeuvre and improves sliding performance.



Parc d'Activités de Laroiseau • 5 rue Ella Maillart • F- 56000 Vannes
Tél : +33 (0)2 97 67 64 83 • Mail : sail@nodusfactory.com www.nodusfactory.com



Pad-HOOK® - Padeye Halyard Organizers

« Adhesive accessory for organising halyards and sheets »



*Garçette textile



Product Name	Glue resistance	Weight	Pad dimensions (mm)		
			Length	Width	Height
Pad-Hook	200 kg	4 gr	45	35	15
Option - glue	Volume	Quantity	Supports		
Nodus-Loc® 12	12 ml	6 padeyes	multiples		

TECHNICAL

- Padeye ready-to-use adhesive in biosourced technical PA
- Length 45 mm & Width 35 mm
- Textile toggle (*optional)

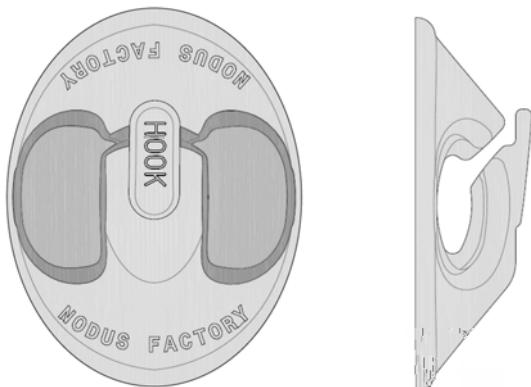

MOUNTING

- 1- Prepare and clean the surface.
 - 2- Mix and apply the two-component adhesive.
 - 3- Glue and maintain pressure for at least 5'.
- Wait 24 hours before use

Information sail@nodusfactory.com

NODUS
FACTORY
MADE IN FRANCE
www.nodusfactory.com



Scan me !

Pad-HOOK® - Padeye Halyard Organizers

« Adhesive accessory for organising halyards and sheets »



The **Pad-Hook®** is a glue-on textile cleat that keeps all your ropes and lines well coiled and always ready to use and within easy reach.

- Ideal for hanging halyards in the cockpit when leaving the clam cleats!
- Very easy to install, your Pad-Hook® glue cleat allows you to organize your onboard stowage

Advantages

- No drilling required, thanks to our bi-component adhesive
- Interchangeable rope with adjustable length
- Simple and easy to use

References

Pad-Hook	20305
-----------------	--------------

Nodus Tips

- Tie your rope correctly and pass the toggle through the skein, then hook the toggle into the Pad-Hook.



Parc d'Activités de Laroiseau • 5 rue Ella Maillart • F- 56000 Vannes
Tél : +33 (0)2 97 67 64 83 • Mail : sail@nodusfactory.com www.nodusfactory.com



Accessories - Ropes & Mooring



Comfort & Mooring

A section for comfort on board: textile connectors and blockers, comfort fittings, tips of all kinds to feel good on board both when sailing and at anchorage.



- ✓ Comfort on board and at anchorage!
- ✓ Memory foam cockpit cushion
- ✓ Boom strap
- ✓ Multifunction strap
- ✓ Elastic bungee sail T-Sandow
- ✓ Dock-line mooring
- ✓ Lazy-jack rope



How to optimize and improve comfort on board!

- A Lazy-Jack rope and these accessories

A range of moorings with a Polyamide core and Polyester sheath | Nodus-Dockline®



A polyester mooring rope with an elongation of <math><25\%</math>, ideal for use at the pontoon, at the quay or for mooring alongside another boat. Pleasant to handle and very resistant to abrasion.



Ropes and moorings

Particularly flexible and light, our polyester mooring for all types of boats (sailing, motor, etc.), provides security, longevity and cushioning of boat movements.

Our mixed mooring rope will provide you with security, durability and good shock absorption.

The quality of the materials used, polyester sheath and polyamide core, guarantees high resistance to abrasion while cushioning the boat's movements thanks to the property of polyamide.

Polyamide core and 32-layer polyester sheath, very good resistance to UV and abrasion.

Features

- Very good flexibility
- Pleasant handling
- UV resistant
- Excellent elasticity <25%
- Comfort on the pontoon and at the quay, gentle mooring
- Easy to splice

If the rope for the sheets and halyards must be as rigid as possible to handle a lot of friction, the rope for the moorings must offer maximum flexibility to absorb hits.

Each rope has a specific use and it is important to check its characteristics to use it properly.

For this, we offer you a comparative table!

Strap S T-close® - Adjustable boom strap

« Adjustable Dyneema® boom strap with T-close connector »



Product Name	Breaking Load	Weight	Loop Length	Boom Height	Sail area
	Basket		Straight	Straight	40 kts
	kg	gr	max cm	cm	m2
S 3 F	750	12	55	12	30
S 3 G	750	16	72	16	30
S 5 H	1900	49	90	20	50
S 6 I	2600	56	110	25	70

TECHNICAL SHEET

- 100% Dyneema®
- ✓ SK78 12 plaits pre-stretched, coated → Light grey/black
- T-close connector → Movable locking piece, several sizes available
- ✓ T-close® connector → Glass-filled PA Tech
- 100% HD polyester overlay
- ✓ Tightly woven and coated → Black or white
- ✓ Structural termination, bonded and crimped in HDPE

Nœud de Grip®



© Nodus Factory

USE

- Adjustable textile "tie" strap connector for attaching the clew of a freeboard mainsail to the boom
- Adjustable, self-locking Dyneema® loop
- How to change the length of the loop :
 - Slide on the T-close® connector, then secure with the Grip® knot.

Information sail@nodusfactory.com

NODUS
FACTORY

MADE IN FRANCE

www.nodusfactory.com



Scan me !

Strap S T-close® - Adjustable boom strap

« Adjustable Dyneema® boom strap with T-close connector »



S T-close® is a 'tie' strap for securing the clew of a free-sailing mainsail to the boom.

➤ Adjustable, self-locking attachment using the T-close® mobile connector.

Advantages

- ❑ Lightweight and quick to install
- ❑ The flexibility of the fabric means that it can be used in line with strains
- ❑ Easy to use → Closes with a minimum of 4 half-keys
- ❑ Highly resistant to UV and abrasion

References

S3 F	20101
S3 G	20102
S5 H	20103
S6 I	20104

Nodus Tips

➤ You can use the T-close adjustable boom strap to attach and adjust the height of your mainsail hoists directly on the boom..



Parc d'Activités de Laroiseau • 5 rue Ella Maillart • F- 56000 Vannes
Tél : +33 (0)2 97 67 64 83 • Mail : sail@nodusfactory.com www.nodusfactory.com



Boomstrap SC[®] - Adjustable boomstrap

« Adjustable Dyneema[®] boomstrap with lashing »



Product Name	Breaking Load	Weight	Loop Length	Boom Height	Sail area
	Basket		Straight	Straight	40 kts
	kg	gr	max cm	cm	m2
Sc 2	1000	9	20	8	30
Sc 3	2000	12	30	12	60
Sc 4	3000	23	40	16	80
Sc 5	4000	30	50	20	100

TECHNICAL SHEET

- 100% Dyneema[®] sewn webbing
- ✓ 48 plaits pre-stretched, coated → black
- Structural eye termination → sewn
- Lashing in Dyneema[®] SK78
- ✓ SK78 12 plaits pre-stretched, coated → light grey / black
- Glued and crimped termination in PEDH

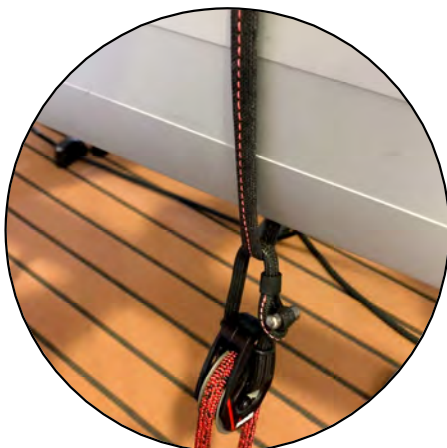

USE

- Adjustable "tie" textile strap connector for attaching the clew of a free-sailing mainsail to the boom
- Loop adjustable by lashing, supplied, fastened with a minimum of 4 half-keys.

Information sail@nodusfactory.com

NODUS
FACTORY
MADE IN FRANCE
www.nodusfactory.com



Scan me !

Boomstrap SC[®] - Adjustable boomstrap

« Adjustable Dyneema[®] boomstrap with lashing »



SC[®] is a "tie" strap used to attach the clew of a free-sailing mainsail to the boom.

➤ Adjustable attachment with lashing supplied in Dyneema[®].

Advantages

- Lightweight and quick to install
- The flexibility of the fabric means that it can be used in line with strains
- Easy to use → Closes with a minimum of 4 half-hitches
- Highly resistant to UV and abrasion

References

Sc 2	20105
Sc 3	20106
Sc 4	20107
Sc 5	20108

NØDUS
FACTORY
MADE IN FRANCE

Parc d'Activités de Laroiseau • 5 rue Ella Maillart • F- 56000 Vannes
Tél : +33 (0)2 97 67 64 83 • Mail : sail@nodusfactory.com www.nodusfactory.com



T-lazy® - Adjustable strope for lazy-jack

« Adjustable textile clamp with T-lazy® connector »



Product Name	Breaking load	Weight	Adjustable Loop mini / maxi
	kg	gr	cm
T-I 3 C	440	18	45/85
T-I 3 R	1100	16	45/85

TECHNICAL SHEET

- ❑ 100% Dyneema® or HD polyester rope
- ✓ (R) SK78 12 plaits pre-stretched, coated → Light grey/black
- ✓ (S) Pre-coated PES → Grey
- ❑ T-lazy® connector → Movable locking piece,
- ✓ Glass-filled PA Tech
- ✓ Structural termination, bonded and crimped in HDPE

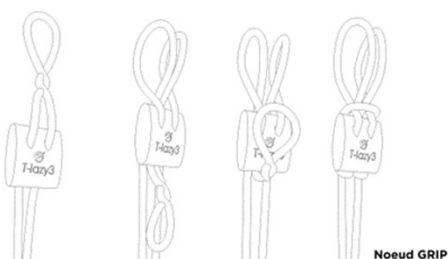
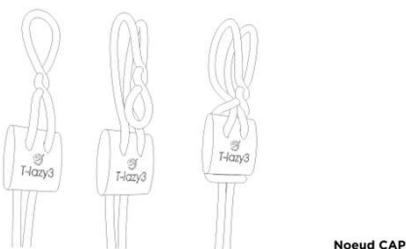

USE

How to change the length of the loop :

- ✓ Slide on the T-lazy® connector, then make the locking closure with the Grip© Knot.

Mounting:

1. Put the textile loop on the T-Lazy® connector
2. Slide the connector to the desired height, take up and tighten the tie, release the tie. The system is locked,

Information sail@nodusfactory.com

NODUS
FACTORY

MADE IN FRANCE

www.nodusfactory.com



Scan me !

T-lazy® - Adjustable strope for lazy-jack

« Adjustable textile clamp with T-lazy® connector »



T-Lazy, adjustable textile blocker for Lazy-bag, Lazy-jack and awning.

- Allows you to fine-tune your Lazy-bags and awnings quickly and easily.
- Adjustable loop, slide on the T-Lazy connector, then lock with the Cap® or Grip® knot in the agitated zone for total locking.

Advantages

- ❑ Easy and quick to use
- ❑ User friendly - Closing - Cap® or Grip® knot, adjustable & quick
- ❑ Replaces knots, clam-cleats and other devices

References

T-I3 C	20161
T-I3 R	20162

Nodus Tips

- You can use the T-lazy® adjustable textile blocker to attach and furl your sails.



NODUS
FACTORY
MADE IN FRANCE

Parc d'Activités de Laroiseau • 5 rue Ella Maillart • F- 56000 Vannes
Tél : +33 (0)2 97 67 64 83 • Mail : sail@nodusfactory.com www.nodusfactory.com



Multi-purpose strap[®] - Polyester HT

« Adjustable multi-purpose strap »

Product Name	Width	Length	Locking resistance
	mm	mm	Kg
Strap 55	25	550	135
Strap 65	25	650	135

TECHNICAL SHEET

- Adjustable strap
- White colour
- UV-resistant HT polyester
- PA 6.6 clip buckle

- Recommended load capacity
- Max 135 kg
- Completely weatherproof

USE

- Multi-purpose fastener
- Clip closure system
- Easy to use
- Fitting of mainsail and headsails
- Trim canvas
- Canopy and bonnet
- Perfect for securing objects to be transported
- For securing light loads

Information sail@nodusfactory.com

NODUS
FACTORY

MADE IN FRANCE

www.nodusfactory.com



Scan me !

Multi-purpose strap®

« Adjustable multi-purpose strap »



Multi-purpose adjustable strap with black plastic buckle-clip system.

- This strap is multi-purpose (storage, locking, tightening, etc.).
- 135KG locking strength (the clip releases but does not break).

Advantages

- Lightweight and durable
- Firm, secure fit
- High-quality ironing buckle
- Material: 100% polyester PES
- ✓ Strap width: 2.5 cm
- ✓ Strap length: 55 cm / 65 cm or made to measure

References

Strap 55	20362
Strap 65	20363
MI strap	xxxxxx



Parc d'Activités de Laroiseau • 5 rue Ella Maillart • F- 56000 Vannes
Tél : +33 (0)2 97 67 64 83 • Mail : sail@nodusfactory.com www.nodusfactory.com



T-Sandow® - Sandow-elastic tensioner

« Tensioner with ferlette »



Product Name	Maximum load capacity	Length of elongation	Length
	Kg	%	cm
T-Sandow	40 kg	70	8 / 13 / 20

TECHNICAL SHEET

- T-Sandow® elastic tensioner
- Various lengths L 8 / 13 / 20 cm
- Stretch length: 70
- Recommended load capacity max. 40 kg
- Completely weatherproof
- 30% fiber-reinforced technical PA T-strap

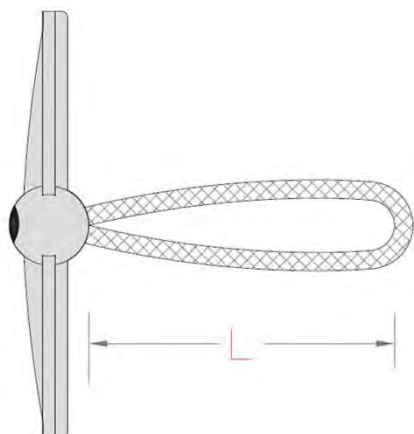

USE

- Furling the mainsail and headsails
 - ✓ Lee cloth
 - ✓ Sail and spinnaker bags
 - ✓ Canopy and bonnet
- Multi-purpose attachment
 - ✓ Fishing rod
 - ✓ Paddle
 - ✓ Boom gaff



Information sail@nodusfactory.com

NØDUS
FACTORY

MADE IN FRANCE

www.nodusfactory.com



Scan me !

T-Sandow® - Sandow-elastic tensioner

« Tensioner with ferlette »



Multi-purpose Nodus T-Sandow® elastic tensioner or toggle, this accessory is suitable for the marine environment.

➤ Locking strength 40KG

The T-Nodus Sandow® tensioner is made from top-of-the-range natural rubber and a high-tenacity polyester sheath. The T-connector is made from technical polyamide.

Advantages

☐ The T-Sandow tensioner is easy to use and install.

References

T-Sandow 8	30006
T-Sandow 13	30007
T-Sandow 20	30008



Parc d'Activités de Laroiseau • 5 rue Ella Maillart • F- 56000 Vannes
Tél : +33 (0)2 97 67 64 83 • Mail : sail@nodusfactory.com www.nodusfactory.com



T-Bat® - Adjustable fender cleat for boats

« Clam cleat" textile blocker for fenders »



Product Name	Breaking Load	Adjustable Loop	
		mini / maxi	mini / maxi
		Low Line	High Line
	kg	cm	cm
T-b 8	1100	35/75	45/90
T-b 10	1600	45/85	50/100

TECHNICAL SHEET

- 100% HD polyester rope
- ✓ Pre-coated PES → Grey
- T-Bat® connector → Movable locking piece,
- ✓ Glass-filled PA Tech
- ✓ Structural termination, bonded and crimped in HDPE

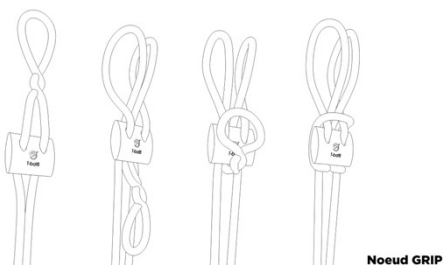
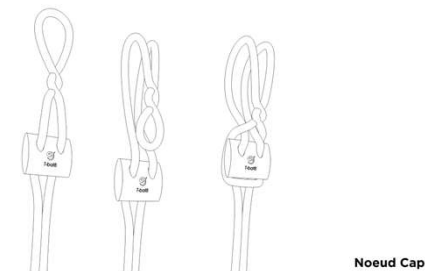

USE

- E T-bat → Adjustable bracket → For fenders and boat guards
- ✓ Can be fixed freely to rails, balconies and handrails
- ✓ Prevents knots

Installation :

1. Pass the strop around the lifeline
2. Place the textile loop on the T-bat connector according to the choice of "Cap or Grip" knot
3. Adjust the height by sliding the connector, release the tie and it's locked.

Information sail@nodusfactory.com

NODUS
FACTORY

MADE IN FRANCE

www.nodusfactory.com



Scan me !

T-Bat® - Adjustable fender cleat for boats

« Clam cleat" textile blocker for fenders »

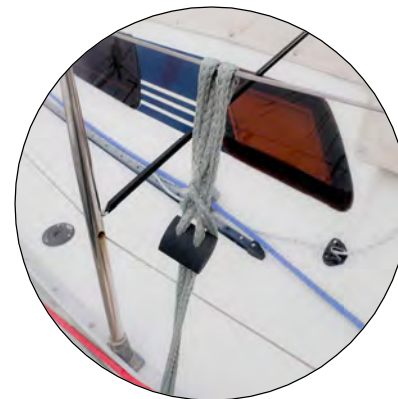

T-bat®, textile device for quickly adjusting and attaching your fenders and fenders to dies.

Allows you to quickly install and adjust your fenders

Adjustable bracket, slide on the T-bat connector, then secure with the Cap® or Grip® knot in agitated areas for total locking.

Advantages

- Quick and easy to install
- Easy to use → Closure → Cap® or Grip® knot → Quick adjustment
- Replaces knots, cleats and other devices

References

T-Bat 8	20163
T-Bat 10	20164



Parc d'Activités de Laroiseau • 5 rue Ella Maillart • F- 56000 Vannes
Tél : +33 (0)2 97 67 64 83 • Mail : sail@nodusfactory.com www.nodusfactory.com



Lab-One® - Cockpit beanbag

« Comfort cushion for the helmsman »

Product Name	Weight	Width	Height	Base
	Gramme	cm	cm	cm
« Blue » Lab One		50	64	45
« Grey » Lab One		50	64	45

TECHNICAL SHEET

- Seat surface and backrest in treated acrylic fabric
- Undercover with polystyrene ball-filled closure
- PA6 zip fastener
- Lab One® model registered by Nodus Factory™



USE

- Ball comfort cushion for helmsman and crew
- ✓ It revolutionises comfort at the helm, an anatomical, non-conformist 'armchair' that offers a new way of sitting or leaning back!
- Freely fixable onto the rope:
 - Nodus Factory® carabiner or textile shackle
 - T-Sandow® elastic tensioner

Information sail@nodusfactory.com

NODUS
FACTORY

MADE IN FRANCE

www.nodusfactory.com



Scan me !

Lab-One® - Cockpit beanbag

« Comfort cushion for the helmsman »



Lab One®, a ball cushion specially designed for comfortable support when heeling. The pressure exerted on the seat compresses the padding to create the backrest support.

Sitting on Lab-One, you can fidget or concentrate on your navigation... But whatever position you adopt, it adapts to your every need.

Its secret? Expanded polystyrene balls enclosed in a vinyl bag, so small that when stacked together they mould perfectly to the shape of your body.

Advantages

- Comfort
- ✓ protects against cold and damp when seated
- Stability
- ✓ lumbar support for better helm control
- ✓ Maintains the seat even when heeling over
- Efficiency
- ✓ extremely light, contains no metal structures
- ✓ Safety and buoyancy guaranteed by polystyrene balls
- ✓ Side pocket with two compartments

References

Lab-One Bleu	20351
Lab-One Gris	20352



Parc d'Activités de Laroiseau • 5 rue Ella Maillart • F- 56000 Vannes
Tél : +33 (0)2 97 67 64 83 • Mail : sail@nodusfactory.com www.nodusfactory.com



Halyard HT[®] - Polyester PES-HT « core and sheath »

« Categorie cruising / croisière »

∅ mm	Breaking load kg	Sail Area 25 kts M2	Sail Area 40 kts M2
4	400	24	11
5	650	39	18
6	810	49	22
7	1230	74	34
8	1650	100	45
10	2500	151	69
12	3500	211	96
14	4500	271	124
16	5100	308	140
18	6290	377	173
20	7100	428	195

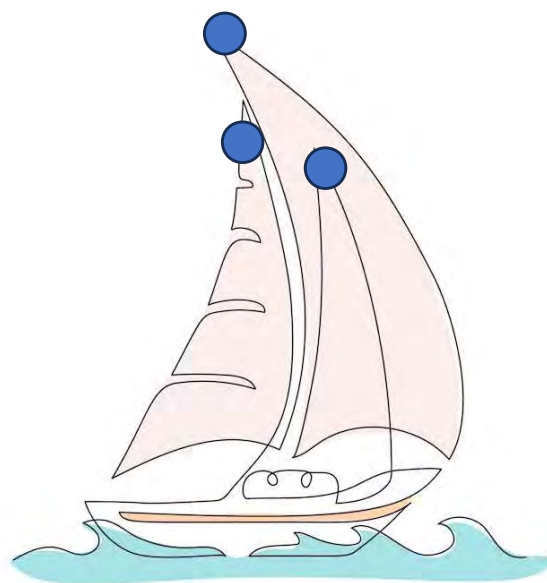

TECHNICAL SHEET

❑ CONSTRUCTION

- ✓ 4 to 6mm: 16 plaits / 8 to 20mm: 32 plaits.
- ✓ Double braid.

❑ COMPOSITION

- ✓ Core : Polyester HT.
- ✓ Cover : Polyester HT.

❑ WORKING STRETCH

- <5%

❑ FEATURES

- UV protection, non-slip in stoppers and easy to splice.

USE

❑ APPLICATIONS

- Excellent control lines, cruising and multipurpose.

Guidelines for Rope Length :

❑ Halyards :

- Main Halyard – Mast length x 2.5
- Genoa Halyard – Mast length x 2.5
- Genoa Halyard (fractional rig) – Mast length x 2
- Spinnaker / gennaker halyard – Mast length x 2.5

Information sail@nodusfactory.com

NODUS
FACTORY

MADE IN FRANCE

www.nodusfactory.com



Scan me !

Halyard HT[®] - Dyneema[®] & Polyester « mixed core and sheath »

«Performance & competition category »

∅ mm	Breaking load kg	Sail Area 25 kts M2	Sail area 40 kts M2
4	600	36	16
5	930	56	26
6	1290	78	35
8	2200	133	60
10	3800	229	104
12	5000	302	137
14	6700	404	184
16	8670	523	238
18	9500	573	261
20	11560	697	318

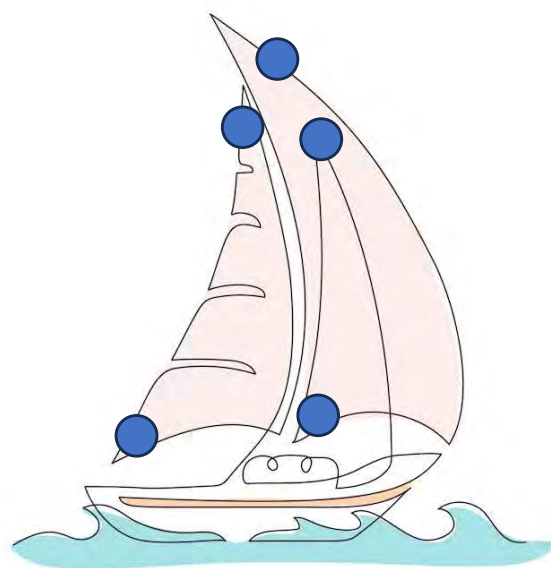

TECHNICAL

❑ CONSTRUCTION

- ✓ 4 to 6mm: 16 plaits / 8 to 20mm: 32 plaits
- ✓ Double braid

❑ COMPOSITION

- ✓ Core: Dyneema[®] SK78 and PES-HT
- ✓ From 10 mm additional braid
- ✓ Cover: PES-HT polyester with high-twist yarn.

❑ LENGTHENING

- ✓ <3%

❑ FEATURES

- ✓ UV protection
- ✓ Abrasion resistant
- ✓ Non-slip coating
- ✓ Good grip on winch and cleat
- ✓ Technical splice

USE

❑ APPLICATIONS

- ✓ Performance and competition halyards and sheets.
- ✓ Multi-purpose line with low elongation

❑ Calculate the length of the halyard:

- ✓ Mainsail halyard - Length of mast x 2.5
- ✓ Genoa halyard - Length of mast x 2.5
- ✓ Genoa halyard (split rig) - Length of mast x 2
- ✓ Spinnaker / gennaker halyard - Length of mast x 2.5

Information sail@nodusfactory.com

NODUS
FACTORY

MADE IN FRANCE

www.nodusfactory.com



Scan me !

Sheet HT® - Polyester PES-HT « core and sheath »

« Categorie cr uising / croisière »

ø mm	Breaking load kg
4	400
5	650
6	810
7	1230
8	1650
10	2500
12	3500
14	4500
16	5100
18	6290
20	7100



TECHNICAL SHEET

❑ CONSTRUCTION

- ✓ 4 to 6mm: 16 plait / 8 to 20mm: 32 plait.
- ✓ Double braid.

❑ COMPOSITION

- ✓ Core: Polyester HT.
- ✓ Cover, Our non-slip fiber, Grip fiber and Polyester HT.

❑ WORKING STRETCH

- <5%

❑ FEATURES

- Non-slip, handling, easy to splice and UV protection.

USE

❑ APPLICATIONS

- Excellent cruising sheet and multipurpose.

Information sail@nodusfactory.com

NODUS
FACTORY

MADE IN FRANCE

www.nodusfactory.com



Scan me !

Sheet HT® – Dyneema® & Polyester « mixed core and sheath »

« Catégorie cruising / croisière »

∅ mm	Breaking load kg	Sail area 25 kts M2	Sail area 40 kts M2
4	490	30	13
5	800	48	22
5	1205	73	33
6	1400	84	38
8	1950	118	54
10	2408	145	66
12	2888	174	79
14	3490	211	96
16	4253	257	117



TECHNICAL SHEET

❑ CONSTRUCTION

- ✓ 4 to 6mm: 16 plait / 8 to 20mm: 32 plait
- ✓ Double braids

❑ COMPOSITION

- ✓ Core: Mixed SK78 & Polypropylene HT.
- ✓ Sheath: Anti-slip coating, grip fiber and PES-HT polyester.

❑ Elongation

- ✓ <3%

❑ CHARACTERISTICS

- ✓ Non-slip
- ✓ Lightweight
- ✓ Good abrasion resistance
- ✓ Easy to splice
- ✓ UV protection

USE

Dyneema® and HT polyester sheeting rope, ideal for spinnaker sheets or mainsails, for coastal and long distance cruising.

A strong, flexible rope with excellent value for money, ideal for most sailors.

APPLICATIONS

Excellent all-round cruising sheet.

Information sail@nodusfactory.com

NODUS
FACTORY

MADE IN FRANCE

www.nodusfactory.com



Scan me !

Lazy-Jack® braid® - Polyester PES-HT

« Coated »

ø mm	Breaking load kg
3	330
4-5	540
6-7	1130
8	2200
10	3090



➤ Made to measure

TECHNICAL SHEET

- CONSTRUCTION
 - ✓ 3 to 10 mm: 16 plaits
 - ✓ Single braid
- COMPOSITION
 - ✓ Polyester PES-HT.
- CHARACTERISTICS
 - ✓ UV protection, easy to splice and abrasion-resistant.
- ACCESSORIES



USE

- APPLICATIONS
 - ✓ Special braid for lazy-jack
- Lazy-Jack Nodusfactory :
 - ✓ Lazy-Jack made to measure in Dyneema® or polyester fabric, ready to install on your sailboat.
 - ✓ This product is only available made to measure and adapted to your sailboat.

Information sail@nodusfactory.com

NODUS
FACTORY

MADE IN FRANCE

www.nodusfactory.com



Scan me !

Mooring-Dockline® - Polyester HT

« Core & Cover »

ø mm	Breaking load kg
8	1500
10	2200
12	3350
14	4010
16	4800
18	6450
20	7100
22	8500
24	10000
26	11700
28	13500



TECHNICAL SHEET

❑ CONSTRUCTION

8 to 14mm: 16 plaits / 16 to 30mm: 32 plaits.
Double braid.

❑ COMPOSITION

Core: Polyester HT
Cover: Polyester HT

❑ CHARACTERISTICS

UV protection, excellent elasticity and easy to splice and handle

USE

❑ WORKING STRETCH

➤ <25%

❑ FEATURES

➤ UV protection, excellent elasticity and easy to splice and to handle

❑ APPLICATIONS

➤ Excellent as a mooring and multipurpose.

Information sail@nodusfactory.com

NODUS
FACTORY

MADE IN FRANCE

www.nodusfactory.com



Scan me !

Application range - Connector on Dyneema® rope

T-close	Strope					
Sail m2	Rope	6 mm	8 mm	10 mm	12 mm	14 mm
Upwind		E T-close 3	E T-close 5	E T-close 6	E T-close 8	E T-close 8
	∅ Strope	3 mm	4 mm	5 mm	6 mm	7 mm
Wind Bft	Wind kts	m2	m2	m2	m2	m2
8 Bft	40	26	55	78	113	113
Downwind		E T-close 3	E T-close 5	E T-close 6	E T-close 8	E T-close 8
	∅ Strope	3 mm	4 mm	5 mm	6 mm	7 mm
Wind Bft	Wind kts	m2	m2	m2	m2	m2
8 Bft	40	41	86	122	175	175

T-bone	Strope					
Sail m2	Rope	6 mm	8 mm	10 mm	12 mm	14 mm
Upwind		E M6	E M8	E M10	E M12	E M14
	∅ Strope	3 mm	4 mm	5 mm	6 mm	7 mm
Wind Bft	Wind kts	m2	m2	m2	m2	m2
8 Bft	40	43	59	89	125	188
Downwind		E M6	E M8	E M10	E M12	E M14
	∅ Strope	3 mm	4 mm	5 mm	6 mm	7 mm
Wind Bft	Wind kts	m2	m2	m2	m2	m2
8 Bft	40	66	92	139	195	293

Spliced eye	Eye strope					
Sail m2	Rope	6 mm	8 mm	10 mm	12 mm	14 mm
Upwind		E eye 3	E eye 4	E eye 5	E eye 6	E eye 7
	∅ Strope	3 mm	4 mm	5 mm	6 mm	7 mm
Wind Bft	Wind kts	m2	m2	m2	m2	m2
8 Bft	40	54	99	154	214	324
Downwind		E eye 3	E eye 4	E eye 5	E eye 6	E eye 7
	∅ Strope	3 mm	4 mm	5 mm	6 mm	7 mm
Wind Bft	Wind kts	m2	m2	m2	m2	m2
8 Bft	40	85	154	239	333	504

T-sail	Strope			
Sail m2	Rope	4 mm	5 mm	6 mm
Upwind		E T-sail 5	E T-sail 6	E T-sail 7
Wind Bft	Wind kts	m2	m2	m2
8 Bft	40	27	47	74
Downwind		E T-sail 5	E T-sail 6	E T-sail 7
Wind Bft	Wind kts	m2	m2	m2
8 Bft	40	43	73	115

T-drop	Strope				
Sail m2	Rope	8 mm	10 mm	12 mm	14 mm
Upwind		E T-d 12	E T-d 12	E T-d 16	E T-d 16
Wind Bft	Wind kts	m2	m2	m2	Wind Bft
8 Bft	40	21	33	30	30
Downwind		E T-d 12	E T-d 12	E T-d 16	E T-d 16
Wind Bft	Wind kts	m2	m2	m2	Wind Bft
8 Bft	40	33	33	47	47

NØDUS

F A C T O R Y

Parc d'Activités de Laroiseau • 5 rue Ella Maillart • F- 56000 Vannes
Tél : +33 (0)2 97 67 64 83 • Mail : Sail@nodusfactory.com
www.nodusfactory.com