

BelAir

COMPRESSED AIR TREATMENT

ACT Series Refrigerated Dryers

Installation & Operation Maintenance Manual

ACT20 - ACT200

(-1) 115/1/60 (-2) 230/1/60

MODEL:

SERIAL NUMBER:



BELAIR TECHNOLOGIES, LLC

**COLORADO OFFICE
10200 E. 106TH AVENUE
BRIGHTON, COLORADO 80601
TEL: (303) 287-6666
FAX: (720) 554-7758**

**DELAWARE OFFICE
149 RICKEY BLVD.
BEAR, DELAWARE 19701
TEL: (302) 832-5800
FAX: (302) 832-5900**

FRIULAIR[®]
Dryers

STATEMENT OF WARRANTY TERMS & CONDITIONS

BelAir's refrigerated air dryers are warranted to be free of defects in materials and workmanship under proper use, installation, and application. Warranty covers parts and labor at fair market value and according to warranty labor replacement guidelines. This warranty shall be for a period of 15 months from date of shipment from our factory or other stocking facilities or 12 months from date of installation. Proof of installation date will be required. All dryers outside the U.S. and Canada carry a parts only warranty.

ALL FREIGHT DAMAGE CLAIMS ARE NOT THE RESPONSIBILITY OF THE MANUFACTURER AND ARE NOT COVERED UNDER WARRANTY AS ALL PRODUCTS ARE SHIPPED F.O.B. SHIPPER.

PLEASE DIRECT ALL FREIGHT CLAIMS TO THE SHIPPER IN QUESTION.

EXCLUSIONS

ADJUSTMENTS TO THE HOT GAS AND MAINTENANCE OF FLOAT AND AUTOMATIC DRAINS AND CONDENSER COILS ARE CONSIDERED TO BE ROUTINE MAINTENANCE AND THEREFORE NON-WARRANTABLE ITEMS AND ARE THE SOLE RESPONSIBILITY OF THE END USER. CONSULT THE INSTALLATION, OPERATION AND MAINTENANCE MANUAL FOR THE ADJUSTMENT AND MAINTENANCE PROCEDURES. THE GEOMETRIC CONFIGURATION OF THE ACT HEAT EXCHANGER REQUIRES A MINIMUM 5 MICRON (1 MICRON RECOMMENDED) PREFILTER TO ENSURE THE LIFE OF THE HEAT EXCHANGER, THE PREFILTER MUST ALSO BE PROPERLY MAINTAINED.

THIS WARRANTY DOES NOT APPLY TO ANY UNIT DAMAGED BY ACCIDENT, MODIFICATION, MISUSE, NEGLIGENCE, OR MISAPPLICATION. DAMAGE TO HEAT EXCHANGERS BY EXPOSURE TO AMMONIA, ANY OTHER CORROSIVE SUBSTANCE OR SUB-FREEZING ENVIRONMENT WILL BE CONSIDERED MISUSE.

INSPECTION

Any refrigerated dryer part or material found defective will be repaired, replaced or refunded, at the sellers option free of charge, provided that BelAir is notified within the above stated warranty period. **All returns of allegedly defective equipment must have prior written authorization.** Said authorization may be obtained through our refrigerated dryer service department. All refrigerated dryers, parts, materials must be returned **freight prepaid** to the Manufacturer's factory for inspection within 30 days of return authorization date. Any shipment returned to the factory collect will be refused.

After inspection, if an item is found to be warrantable, the repaired item or replacement will be returned normal ground freight prepaid within the continental United States and Canada. In the event an item is deemed non-warranty due to improper usage, maintenance, improper installation, abuse, alteration or operator error the customer is responsible for all charges (including parts, labor or replacement costs) incurred resolving the warranty claim. Expedited shipment costs are the responsibility of the requestor.

Any replacement part or material is warranted only to the extent of the remaining warranty period of the dryer or to the extent as provided by the supplier, whichever is longer.

IDENTIFICATION PLATE

The identification plate is located on the back of the dryer and shows all the primary data of the machine. Upon installation, fill in the table on the previous page with all the data shown on the identification plate. This data should always be referred to when calling the manufacturer or distributor.

The removal or alteration of the identification plate will void the warranty rights.

DISCLAIMER

The warranty does not cover any responsibility or liability for direct or indirect damages to persons, or equipment caused by improper usage or maintenance, and is limited to manufacturing defects only. Refer to BelAir Warranty policy manual for travel, mileage and special charge considerations. The warranty will be immediately voided if there are changes or alterations to the dryer.

FILTERS AND DRAINS

Filters and drains are warranted to be free from defects in material and workmanship, under proper use, installation, application and maintenance in accordance with written specifications for a period of one year from date of purchase. Elements, o-rings and float drains are considered consumable items and are warranted at installation only.

WHO TO CONTACT IF YOU HAVE A WARRANTY CLAIM:

BelAir Technologies, LLC	Phone	(302) 832-5800	Delaware
		(303) 287-6666	Colorado
	Fax	(302) 832-5900	Delaware
		(720) 554-7758	Colorado

All freight damage claims should be filed within 15 working days and should be directed to the carrier.

TABLE OF CONTENTS

SAFETY RULES

- 1.1 Explanation of Convention Symbols Used in This Manual
- 1.2 Warnings
- 1.3 Proper Use of the Dryer

INSTALLATION

- 2.1 Transporting the Unit
- 2.2 Installation Site
- 2.3 Installation Layout & Correction Factors
- 2.4 Connection to the Compressed Air system
- 2.5 Connection to the Main Power
- 2.6 Condensate Drain

START-UP

- 3.1 Preliminary Operations
- 3.2 Initial Start-Up
- 3.3 Start-up and Shut-down

4. TECHNICAL SPECIFICATIONS

- 4.1 Technical Specifications ACT20-1 – ACT50-1 (115/1/60)
- 4.2 Technical Specifications ACT20-2 – ACT50-2 (230/1/60)
- 4.3 Technical Specifications ACT75-1 – ACT150-1 (115/1/60)
- 4.4 Technical Specifications ACT75-2 – ACT150-2 (230/1/60)
- 4.5 Technical Specifications ACT200-1 (115/1/60)
- 4.6 Technical Specifications ACT200-2 (230/1/60)

5. TECHNICAL COMPONENT INFORMATION

- 5.1 Control Panel ACT 20-150
- 5.2 Control Panel ACT 200
- 5.3 Operation
- 5.4 Flow Diagram
- 5.5 Refrigeration Compressor
- 5.6 Condenser Unit
- 5.7 Filter Drier
- 5.8 Capillary Tube
- 5.9 ACT Heat Exchanger Module
- 5.10 Hot Gas By-pass Valve
- 5.11 Refrigerant Pressure Switches
- 5.12 Electronic Controller DTT11
- 5.13 Electrical Schematic ACT20-1 – ACT200-1 (115/1/60)
- 5.14 Electrical Schematic ACT20-2 – ACT200-2 (230/1/60)

6. MAINTENANCE/SERVICE PARTS

- 6.1 Maintenance Schedule
- 6.2 Replacement Parts

7. TROUBLESHOOTING

- 7.1 Troubleshooting Guide

8. UNIT DRAWINGS-EXPLODED VIEWS

- 8.1 Exploded View ACT20 – ACT50
- 8.2 Exploded View ACT75
- 8.3 Exploded View ACT100 – ACT150
- 8.4 Exploded View ACT200

1.1 DEFINITION OF THE SAFETY SYMBOLS



Carefully read instruction manual before attempting any service or maintenance procedures on the dryer.



Caution warning sign. Risk of danger or possibility of damage to equipment, if related text is not followed properly.



Electrical hazard. Warning message indicates practices or procedures that could result in personal injury or fatality if not followed correctly.



Danger hazard. Part or system under pressure.



Danger hazard. High temperature conditions exist during operation of system. Avoid contact until system or component has dissipated heat.



Danger hazard. Treated air is not suitable for breathing purposes; serious injury or fatality may result if precautions are not followed.



Danger hazard: In case of fire, use an approved fire extinguisher, water is not an acceptable means in cases of electrical fire



Danger hazard. Do not operate equipment with panels removed.



Maintenance or control operation to be performed by qualified personnel only ¹.



Compressed air inlet connection point.



Compressed air outlet connection point.



Condensate drain connection point.



Operations that can be performed by the operator of the machine, if qualified ¹.

NOTE: Text that specifies items of note to be taken into account does not involve safety precautions.



In designing this unit a lot of care has been devoted to environmental protection:

- CFC free refrigerants
- CFC free insulation parts
- Energy saving design
- Limited acoustic emission
- Dryer and relevant packaging composed of recyclable materials

This symbol requests that the user heed environmental considerations and abide with suggestions annotated with this symbol.

¹ Experienced and trained personnel familiar with national and local codes, capable to perform the needed activities, identify and avoid possible dangerous situations while handling, installing, using and servicing the machine. Ensuring compliance to all statutory regulations.

1.2 WARNINGS



Compressed air is a highly hazardous energy source.

Never work on the dryer with pressure in the system.

Never point the compressed air or the condensate drain outlet hoses towards anybody.

The user is responsible for the proper installation of the dryer. Failure to follow instructions given in the "Installation" chapter will void the warranty. Improper installation can create dangerous situations for personnel and/or damages to the machine could occur.



Only qualified personnel are authorized to service electrically powered devices. Before attempting maintenance, the following conditions must be satisfied :

- Ensure that main power is off, machine is locked out, tagged for service and power cannot be restored during service operations.
- Ensure that valves are shut and the air circuit is at atmospheric pressure. De-pressurize the dryer.



Warranty does not apply to any unit damaged by accident, modification, misuse, negligence or misapplication. Unauthorized alterations will immediately void the warranty.



In case of fire, use an approved fire extinguisher, water is not an acceptable means in cases of electrical fire.

1.3 PROPER USE OF THE DRYER

This dryer has been designed, manufactured and tested for the purpose of separating the humidity normally contained in compressed air. Any other use has to be considered improper.

The Manufacturer will not be responsible for any problem arising from improper use; the user will bear responsibility for any resulting damage.

Moreover, the correct use requires the adherence to the installation instructions, specifically:

- Voltage and frequency of the main power.
- Pressure, temperature and flow-rate of the inlet air.
- Ambient temperature.



The purpose of the machine is the removal of water and residual oil vapor present in compressed air. The dried air cannot be used for respiration purposes or for operations leading to direct contact with food products.

This dryer is not suitable for the treatment of dirty air or of air containing solid particles.

2.1 TRANSPORTING THE UNIT

Check for visible loss or damage, if no visible damage is found place the unit near to the installation point and unpack the contents.

- Always keep the dryer in the upright vertical position. Damage to components could result if unit is laid on its side or if placed upside down.
- Store machine in a clean, dry environment, do not expose to severe weather environments.



The packaging materials are recyclable. Dispose of material in compliance with the rules and regulations in force in the destination country.

2.2 INSTALLATION SITE



Failure to install dryer in the proper ambient conditions will affect the dryer's ability to condense refrigerant gas. This can cause higher loads on the compressor, loss of dryer efficiency and performance, overheated condenser fan motors, electrical component failure and dryer failure due to the following: compressor loss, fan motor failure and electrical component failure. Failures of this type will affect warranty considerations.

Do not install dryer in an environment of corrosive chemicals, explosive gasses, poisonous gasses; steam heat, areas of high ambient conditions or extreme dust and dirt.



In case of fire, use an approved fire extinguisher, water is not an acceptable means in cases of electrical fire.

Minimum installation requirements:

- Select a clean dry area, free from dust, and protected from atmospheric disturbances.
- The supporting plate must be smooth, horizontal and able to hold the weight of the dryer.
- Minimum ambient temperature is 34°F, see data plate for maximum temperature.
- Allow at least 40 inches of clearance on each side of the dryer for proper ventilation and circulation through the condenser. The space is also necessary to facilitate maintenance operations. The dryer does not require attachment to the floor surface, however installations where the unit is suspended require an attachment to the hanging apparatus.

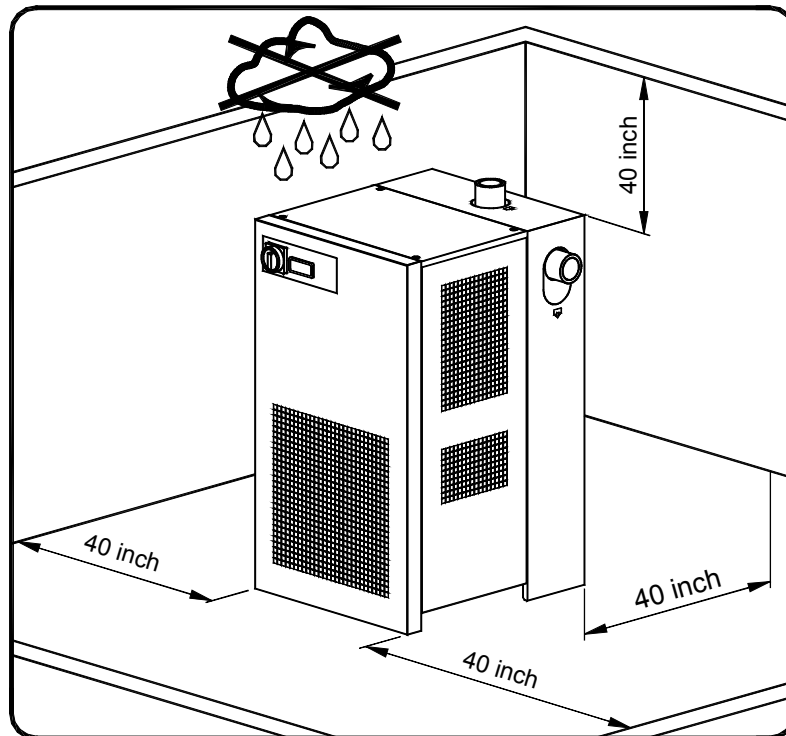

2.3 INSTALLATION LAYOUT & CORRECTION FACTORS

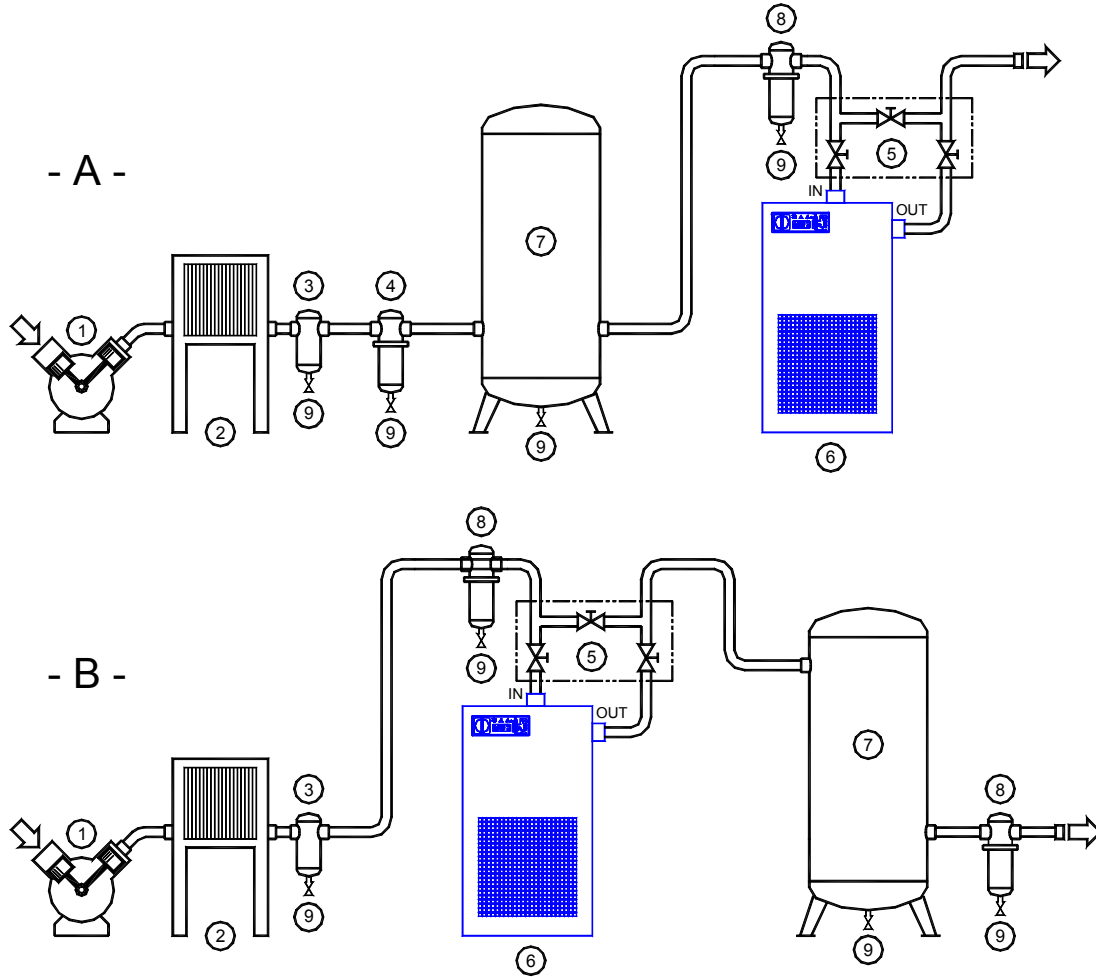

- | | | | |
|---|----------------------|---|---------------------|
| 1 | Air Compressor | 6 | Dryer |
| 2 | Aftercooler | 7 | Compressed Air Tank |
| 3 | Condensate Separator | 8 | Final Filter |
| 4 | Pre-Filter | 9 | Condensate Drain |
| 5 | By-Pass Group | | |

Type A installation is suggested when the compressor operates at reduced intermittence and the total consumption equals the compressor flow rate.

Type B installation is suggested when the air consumption can consistently change with peak values highly exceeding the flow rate of the compressor. The capacity of the tank must be sized in order to compensate eventual instantaneous demand conditions (peak air consumption).

Correction factor for operating pressure changes:									
Inlet air pressure	psig	60	80	100	120	140	160	180	200
Correction Factor		0.80	0.91	1.00	1.08	1.14	1.18	1.21	1.22
Correction factor for ambient temperature changes:									
Ambient temperature	°F	80	90	100	105	110	115		
Correction Factor		1.17	1.12	1.00	0.92	0.83	0.72		
Correction factor for inlet air temperature changes:									
Air temperature	°F	90	100	105	110	120	130		
Correction Factor		1.22	1.00	0.89	0.79	0.63	0.50		
Correction factor for DewPoint changes:									
DewPoint	°F	33-39		40-44		45-49		50-54	
Correction Factor		1.00		1.09		1.22		1.40	

2.4 CONNECTION TO THE COMPRESSED AIR SYSTEM



Operations to be performed by qualified personnel only. Never work on compressed air system under pressure. The user is responsible to ensure that the dryer will never be operated with pressure exceeding the maximum pressure rating on the unit data tag. Over-pressurizing the dryer could be dangerous for both the operator and the unit.

The air temperature and the scfm entering the dryer must comply within the limits stated on the data nameplate. The system connecting piping must be kept free from dust, rust, chips and other impurities, and must be consistent with the flow-rate of the dryer. In order to perform maintenance operations, it is recommended that a dryer by-pass system be installed, as shown in illustration 1.1.

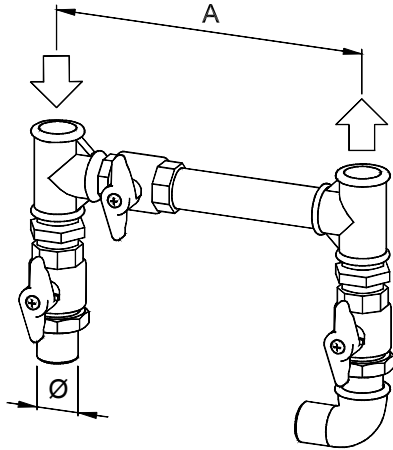

Illustration 1.1

Particular measures have been taken to reduce the amount of vibration that could occur during the operation. Therefore, we recommend the use of connecting pipes that are able to insulate the vibration. (Flexible hoses, vibration damping fittings, etc.)

2.5 ELECTRICAL CONNECTIONS



Qualified personnel should carry out connecting unit to the main power. Be sure to check the local codes in your area.

Before connecting the unit to the electrical supply, verify the data nameplate for the proper electrical information. Voltage tolerance is +/- 5%.

115/1/60 dryers are supplied with a standard North American power cord and plug assembly (two poles and a ground).

230/1/60 is supplied with a junction box. Be sure to provide the proper fuses or breakers based on the data tag information located on the back of the unit. The main power receptacle must be protected with a thermal overload relay ($I_{\Delta n} + 0.03A$), rated to the power consumption of the dryer (refer to data nameplate for nominal values). The power supply cord must meet or exceed ratings for the total amp draw of the unit.



Connect to a properly grounded outlet. Improper connection of the equipment-grounding conductor can result in risk of electric shock. Do not use adapters on the plug receptacle- if it does not fit the outlet, have a proper outlet installed by a qualified electrician.

2.6 CONDENSATE DRAIN



Discharge is at system pressure. Drain line should be secured. Never point the condensate drain line towards anybody.

The dryer comes with a flexible plastic drain tube (1/4" in diameter and 60 in long) for the connection to suitable drain.

Removal of the condensate occurs through a solenoid valve protected with a mechanical filter. In order to avoid clogging of the solenoid valve, the condensate from the cyclone separator is previously filtered, then discharged. An adjustable electronic timer operates the solenoid valve coil.

The drain cannot be connected to pressurized systems.



Condensate may contain oil. Comply with applicable laws concerning disposal. An oil-water separator should be installed before the air inlet to the dryer for the purpose of removing condensate drainage coming from compressors, dryers, tanks, filters, etc.

3.1 PRELIMINARY OPERATION



Verify that the operating parameters match with the nominal values stated on the data nameplate of the dryer (voltage, frequency, air pressure, air temperature, ambient temperature, etc.).

This dryer has been thoroughly tested, packaged and inspected prior to shipment. Nevertheless, the unit could be damaged during transportation, check the integrity of the dryer during initial start-up and monitor operation during the first hours of operation.



Qualified personnel must perform the initial start-up.
When installing and operating this equipment, comply with all *National Electrical Code and any applicable federal, state and local codes.*

3.2 INITIAL START-UP



This procedure should be followed on initial start-up, after periods of extended shutdown or following maintenance procedures.

Qualified personnel must perform the start-up.

Sequence of operations (refer to paragraph 5.1 Control Panel) :

- Ensure that all the steps of the "Installation" chapter have been observed.
- Ensure that the connection to the compressed air system is correct and that the piping is suitably fixed and supported.
- Ensure that the condensate drain pipe is properly fastened and connected to a collection system or container.
- Ensure that the by-pass system (if installed) is open and the dryer is isolated
- Ensure that the manual valve of the condensate drain circuit is open.
- Remove any packaging and other material which could obstruct the area around the dryer.
- Activate the mains switch.
- Switch on the dryer by closing the main switch on the control panel (pos. 1).
- Ensure that DTT11 electronic instrument is ON.
- Ensure the consumption matches with the values of the data plate.
- **Ensure the fan work properly - wait for its first interventions.**
- Allow the dryer temperature to stabilize at the pre-set value.
- Slowly open the air inlet valve.
- Slowly open the air outlet valve.
- Slowly close the central by-pass valve of the system (if installed).
- Check the piping for air leakage.
- Ensure the drain is regularly cycling - wait for its first interventions.

3.3 START-UP AND SHUT DOWN



Start-up (refer to paragraph 5.1 Control Panel) :

- Check the condenser for cleanliness.
- Verify that the system is powered.
- Activate the main switch on the control panel (pos. 1).
- Ensure that DTT11 electronic instrument is ON.
- Wait a few minutes; verify that the DewPoint temperature displayed on DTT11 electronic instrument is correct and that the condensate is regularly drained.
- Switch on the air compressor.



Shut down (refer to paragraph 5.1 Control Panel) :

- Verify that the DewPoint temperature displayed on DTT11 electronic instrument is correct.
- Switch off the air compressor.
- After few minutes, switch off the main switch on the control panel of the dryer (pos. 1).

NOTE : A DewPoint included in the green operating area of the DTT11 electronic instrument is correct according to the possible working conditions (flow-rate, temperature of the incoming air, ambient temperature, etc.)

During the operation, the refrigerating compressor will run continuously. The dryer must remain on during the full usage period of the compressed air, even if the air compressor works intermittently.

4.1 TECHNICAL SPECIFICATIONS ACT20-1 – ACT50-1 (115/1/60)

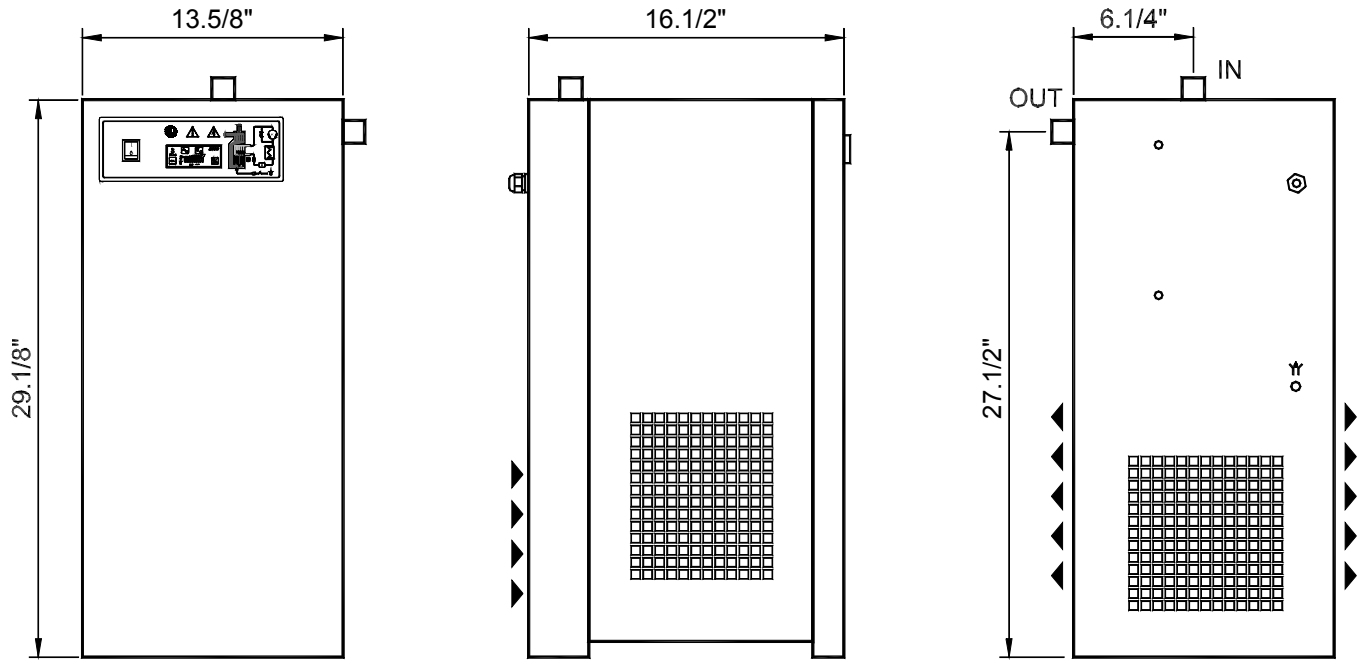

MODEL	ACT20-1	ACT30-1	ACT50-1
Air flow at nominal condition ¹	20 scfm	30 scfm	50 scfm
Pressure DewPoint at nominal condition ¹	38 °F		
Nominal (max.) ambient temperature	100 °F (115 °F)		
Minimum ambient temperature	35 °F		
Nominal (max.) inlet air temperature	100 °F (130 °F)		
Nominal (max.) inlet air pressure	100psig (200psig)		
Maximum outlet air pressure drop-ΔP	0.5 psi	1.2 psi	2.2 psi
Inlet-Outlet air connection	1/2" NPT-F		
Refrigerant - Charge	R134.a - 6.1/2 oz.	R134.a - 6.1/2 oz.	R134.a - 10.1/4 oz.
Cooling air fan flow	180 cfm	180 cfm	180 cfm
Heat Load	1650 Btu/h	2100 Btu/h	3500 Btu/h
Voltage	115/1/60		
Nominal refrigeration compressor power	1/8 HP	1/6 HP	1/4 HP
Nominal electrical consumption	210W - 2.5A	250W - 3.0A	350W - 3.9A
Maximum electrical consumption	230W - 2.7A	290W - 3.3A	420W - 4.3A
Maximum noise level	< 70dba at 1m		
Weight net - gross	62 - 70 lbs	66 - 75 lbs	70 - 79 lbs

¹ The nominal condition refers to ambient temperature of 100°F with inlet air 100 psig and 100°F

Correction factor for operating pressure changes:									
Inlet air pressure	psig	60	80	100	120	140	160	180	200
Correction Factor		0.80	0.91	1.00	1.08	1.14	1.18	1.21	1.22
Correction factor for ambient temperature changes:									
Ambient temperature	°F	80	90	100	105	110	115		
Correction Factor		1.17	1.12	1.00	0.92	0.83	0.72		
Correction factor for inlet air temperature changes:									
Air temperature	°F	90	100	105	110	120	130		
Correction Factor		1.22	1.00	0.89	0.79	0.63	0.50		
Correction factor for DewPoint changes:									
DewPoint	°F	33-39	40-44	45-49	50-54				
Correction Factor		1.00	1.09	1.22	1.40				

4.2 TECHNICAL SPECIFICATIONS ACT20-2 – ACT50-2 (230/1/60)

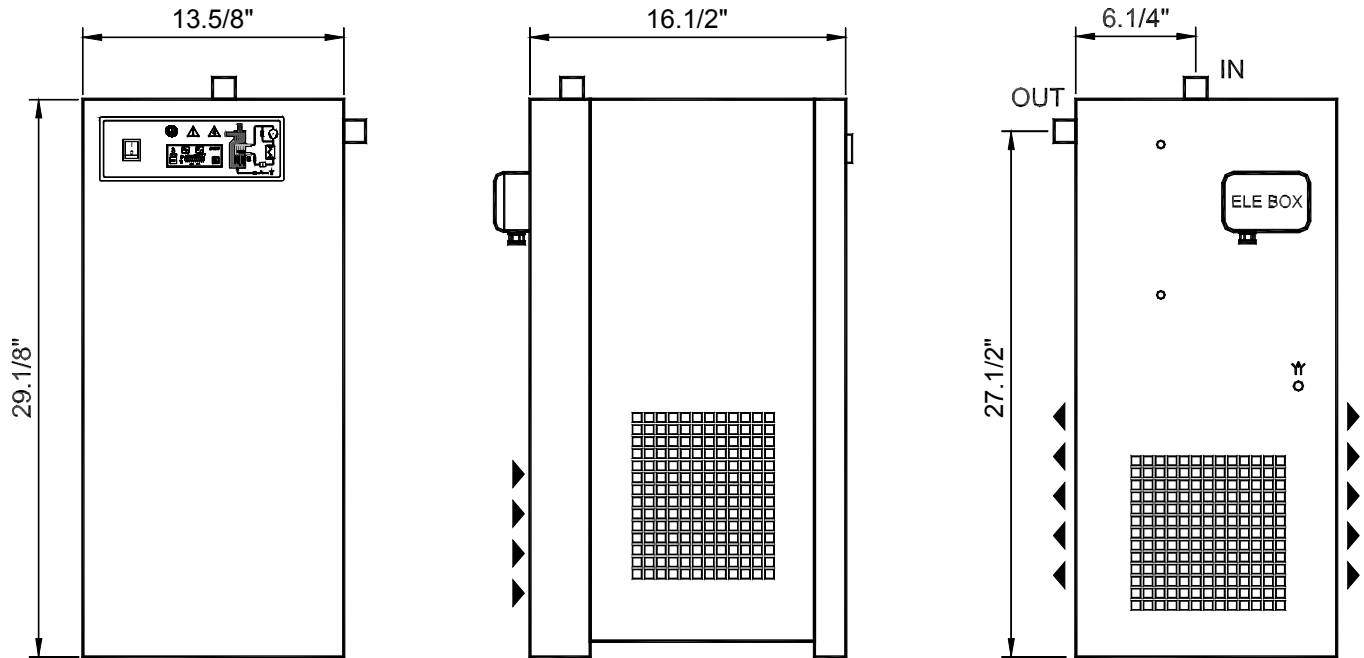

MODEL	ACT20-2	ACT30-2	ACT50-2
Air flow at nominal condition ¹	20 scfm	30 scfm	50 scfm
Pressure DewPoint at nominal condition ¹	38 °F		
Nominal (max.) ambient temperature	100 ° F (115 °F)		
Minimum ambient temperature	35 °F		
Nominal (max.) inlet air temperature	100 °F (130 °F)		
Nominal (max.) inlet air pressure	100psig (200psig)		
Maximum outlet air pressure drop-ΔP	0.5 psi	1.2 psi	2.2 psi
Inlet-Outlet air connection	1/2" NPT-F		
Refrigerant - Charge	R134.a - 6.1/2 oz.	R134.a - 6.1/2 oz.	R134.a - 10.1/4 oz.
Cooling air fan flow	180 cfm	180 cfm	240 cfm
Heat Load	1650 Btu/h	2100 Btu/h	4000 Btu/h
Voltage	230/1/60		
Nominal refrigeration compressor power	1/8 HP	1/6 HP	1/4 HP
Nominal electrical consumption	210W - 1.4A	250W - 1.7A	350W - 2.5A
Maximum electrical consumption	230W - 1.6A	290W - 1.9A	420W - 2.8A
Maximum noise level	< 70dba at 1m		
Weight net - gross	62 - 70 lbs	66 - 75 lbs	70 - 79 lbs

¹ The nominal condition refers to ambient temperature of 100°F with inlet air 100 psig and 100°F

Correction factor for operating pressure changes:									
Inlet air pressure	psig	60	80	100	120	140	160	180	200
Correction Factor		0.80	0.91	1.00	1.08	1.14	1.18	1.21	1.22
Correction factor for ambient temperature changes:									
Ambient temperature	°F	80	90	100	105	110	115		
Correction Factor		1.17	1.12	1.00	0.92	0.83	0.72		
Correction factor for inlet air temperature changes:									
Air temperature	°F	90	100	105	110	120	130		
Correction Factor		1.22	1.00	0.89	0.79	0.63	0.50		
Correction factor for DewPoint changes:									
DewPoint	°F	33-39	40-44	45-49	50-54				
Correction Factor		1.00	1.09	1.22	1.40				

4.3 TECHNICAL SPECIFICATIONS ACT75-1 – ACT150-1 (115/1/60)

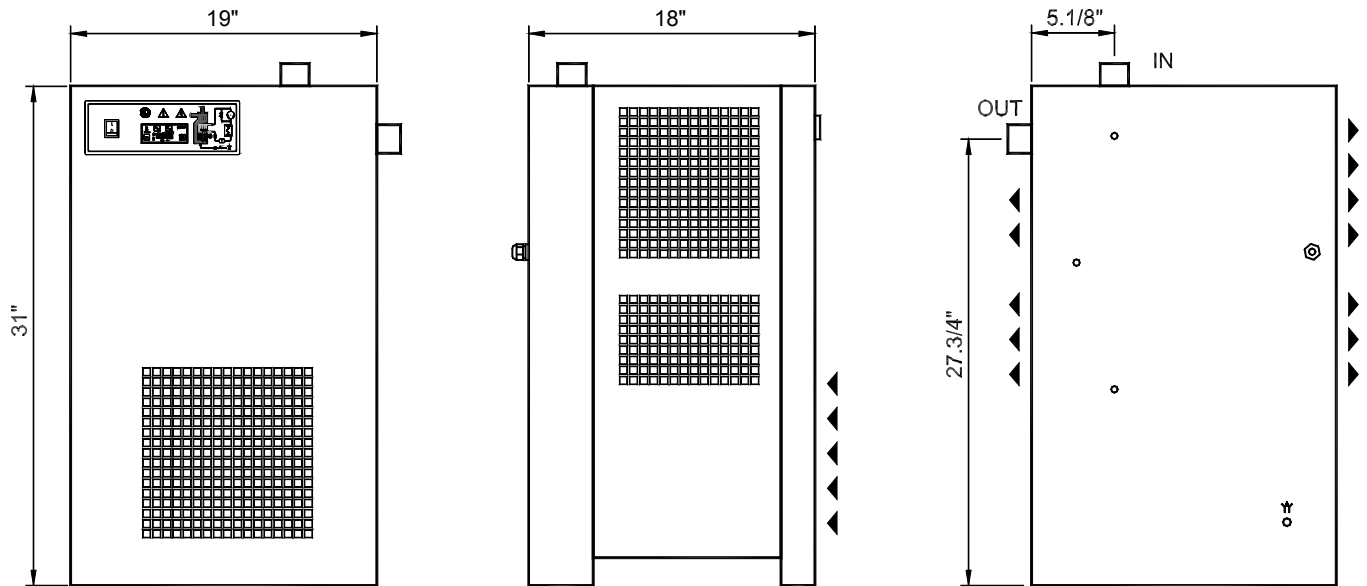

MODEL	ACT75-1	ACT100-1	ACT125-1	ACT150-1
Air flow at nominal condition ¹	75 scfm	100 scfm	125 scfm	150 scfm
Pressure DewPoint at nominal condition ¹	38 °F			
Nominal (max.) ambient temperature	100 ° F (115 °F)			
Minimum ambient temperature	35 °F			
Nominal (max.) inlet air temperature	100 °F (130 °F)			
Nominal (max.) inlet air pressure	100psig (200psig)			
Maximum outlet air pressure drop-ΔP	3.2 psi	1.9 psi	2.9 psi	3.4 psi
Inlet-Outlet air connection	1" NPT-F		1.1/4" NPT-F	
Refrigerant - Charge	R134.a - 11.1/2 oz.	R134.a - 14.1/4 oz.	R404A - 22.1/2 oz.	R404A - 26.1/2 oz.
Cooling air fan flow	240 cfm	240 cfm	350 cfm	350 cfm
Heat Load	4500 Btu/h	5800 Btu/h	8500 Btu/h	8500 Btu/h
Voltage	115/1/60			
Nominal refrigeration compressor power	1/4+ HP	1/3+ HP	1/2 HP	1/2 HP
Nominal electrical consumption	450W - 5.3A	560W - 6.3A	800W - 7.8A	850W - 8.0A
Maximum electrical consumption	520W - 5.8A	630W - 6.8A	980W - 9.3A	1020W - 9.6A
Maximum noise level	< 70dba at 1m			
Weight net - gross	90 - 106 lbs	98 - 114 lbs	105 - 121 lbs	110 - 126 lbs

¹ The nominal condition refers to ambient temperature of 100°F with inlet air 100 psig and 100°F

Correction factor for operating pressure changes:									
Inlet air pressure	psig	60	80	100	120	140	160	180	200
Correction Factor		0.80	0.91	1.00	1.08	1.14	1.18	1.21	1.22

Correction factor for ambient temperature changes:							
Ambient temperature	°F	80	90	100	105	110	115
Correction Factor		1.17	1.12	1.00	0.92	0.83	0.72

Correction factor for inlet air temperature changes:							
Air temperature	°F	90	100	105	110	120	130
Correction Factor		1.22	1.00	0.89	0.79	0.63	0.50

Correction factor for DewPoint changes:					
DewPoint	°F	33-39	40-44	45-49	50-54
Correction Factor		1.00	1.09	1.22	1.40

4.4 TECHNICAL SPECIFICATIONS ACT75-2 – ACT150-2 (230/1/60)

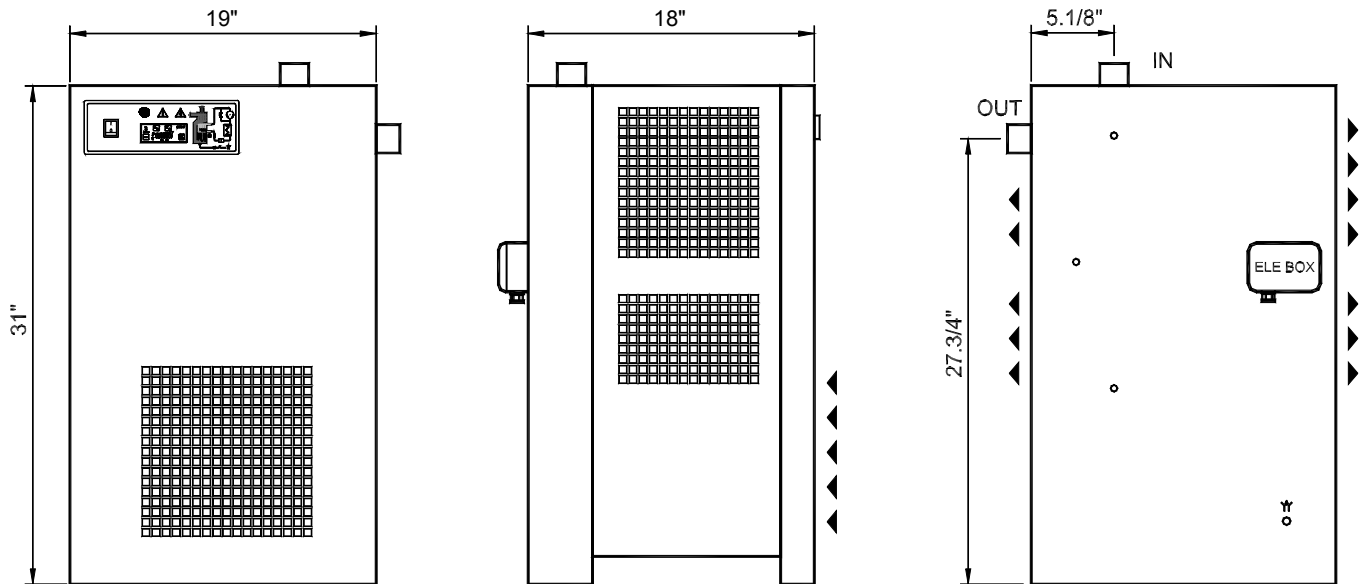

MODEL	ACT75-2	ACT100-2	ACT125-2	ACT150-2
Air flow at nominal condition ¹	75 scfm	100 scfm	125 scfm	150 scfm
Pressure DewPoint at nominal condition ¹	38 °F			
Nominal (max.) ambient temperature	100 ° F (115 °F)			
Minimum ambient temperature	35 °F			
Nominal (max.) inlet air temperature	100 °F (130 °F)			
Nominal (max.) inlet air pressure	100psig (200psig)			
Maximum outlet air pressure drop-ΔP	3.2 psi	1.9 psi	2.9 psi	3.4 psi
Inlet-Outlet air connection	1" NPT-F		1.1/4" NPT-F	
Refrigerant - Charge	R134.a - 11.1/2 oz.	R134.a - 14.1/4 oz.	R404A - 22.1/2 oz.	R404A - 26.1/2 oz.
Cooling air fan flow	240 cfm	350 cfm	350 cfm	350 cfm
Heat Load	4500 Btu/h	5800 Btu/h	8500 Btu/h	8500 Btu/h
Voltage	230/1/60			
Nominal refrigeration compressor power	1/4+ HP	1/3+ HP	1/2 HP	1/2 HP
Nominal electrical consumption	450W - 2.9A	560W - 3.5A	800W - 4.5A	850W - 4.7A
Maximum electrical consumption	520W - 3.1A	630W - 3.8A	980W - 5.3A	1020W - 5.5A
Maximum noise level	< 70dba at 1m			
Weight net - gross	90 - 106 lbs	98 - 114 lbs	105 - 121 lbs	110 - 126 lbs

¹ The nominal condition refers to ambient temperature of 100°F with inlet air 100 psig and 100°F

Correction factor for operating pressure changes:									
Inlet air pressure	psig	60	80	100	120	140	160	180	200
Correction Factor		0.80	0.91	1.00	1.08	1.14	1.18	1.21	1.22
Correction factor for ambient temperature changes:									
Ambient temperature	°F	80	90	100	105	110	115		
Correction Factor		1.17	1.12	1.00	0.92	0.83	0.72		
Correction factor for inlet air temperature changes:									
Air temperature	°F	90	100	105	110	120	130		
Correction Factor		1.22	1.00	0.89	0.79	0.63	0.50		
Correction factor for DewPoint changes:									
DewPoint	°F	33-39	40-44	45-49	50-54				
Correction Factor		1.00	1.09	1.22	1.40				

4.5 TECHNICAL SPECIFICATIONS ACT200-1 (115/1/60)

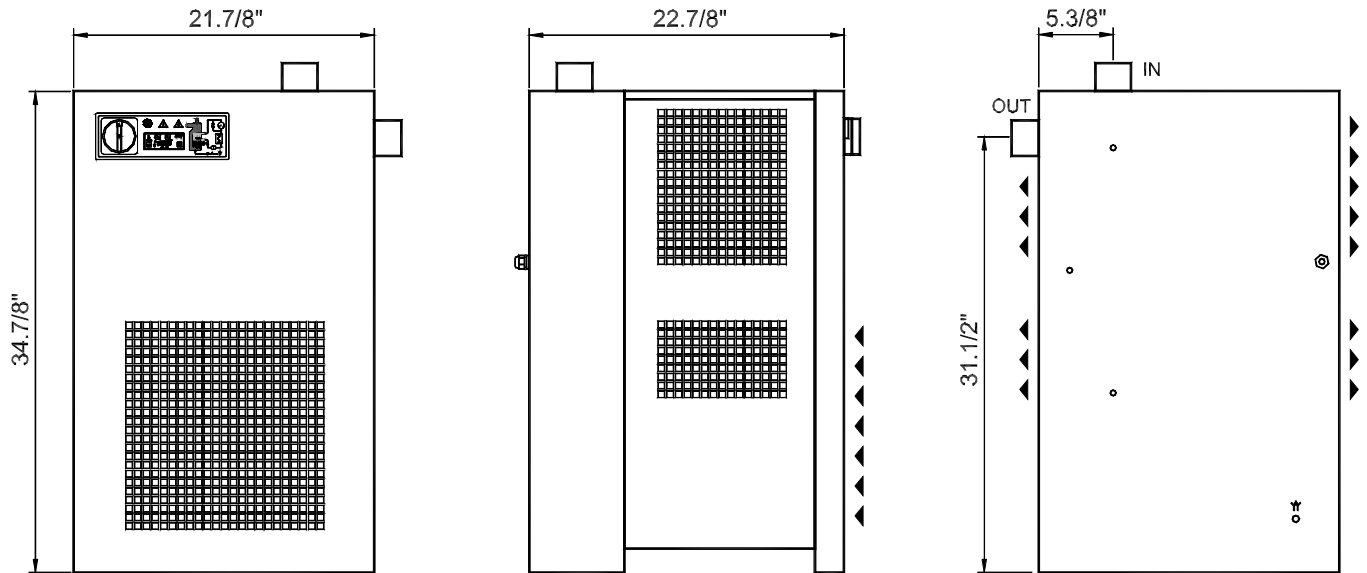

MODEL	ACT200-1
Air flow at nominal condition ¹	200 scfm
Pressure DewPoint at nominal condition ¹	38 °F
Nominal (max.) ambient temperature	100 ° F (115 °F)
Minimum ambient temperature	35 °F
Nominal (max.) inlet air temperature	100 °F (130 °F)
Nominal (max.) inlet air pressure	100psig (200psig)
Maximum outlet air pressure drop-ΔP	2.3 psi
Inlet-Outlet air connection	1.1/2" NPT-F
Refrigerant - Charge	R404A - 27 oz.
Cooling air fan flow	530 cfm
Heat Load	10300 Btu/h
Voltage	115/1/60
Nominal refrigeration compressor power	1/2+ HP
Nominal electrical consumption	1000W - 9.3A
Maximum electrical consumption	1220W - 11.3A
Maximum noise level	< 70dbA at 1m
Weight net - gross	125 - 145 lbs

¹ The nominal condition refers to ambient temperature of 100°F with inlet air 100 psig and 100°F

Correction factor for operating pressure changes:									
Inlet air pressure	psig	60	80	100	120	140	160	180	200
Correction Factor		0.80	0.91	1.00	1.08	1.14	1.18	1.21	1.22

Correction factor for ambient temperature changes:							
Ambient temperature	°F	80	90	100	105	110	115
Correction Factor		1.17	1.12	1.00	0.92	0.83	0.72

Correction factor for inlet air temperature changes:							
Air temperature	°F	90	100	105	110	120	130
Correction Factor		1.22	1.00	0.89	0.79	0.63	0.50

Correction factor for DewPoint changes:					
DewPoint	°F	33-39	40-44	45-49	50-54
Correction Factor		1.00	1.09	1.22	1.40

4.6 TECHNICAL SPECIFICATIONS ACT200-2 (230/1/60)

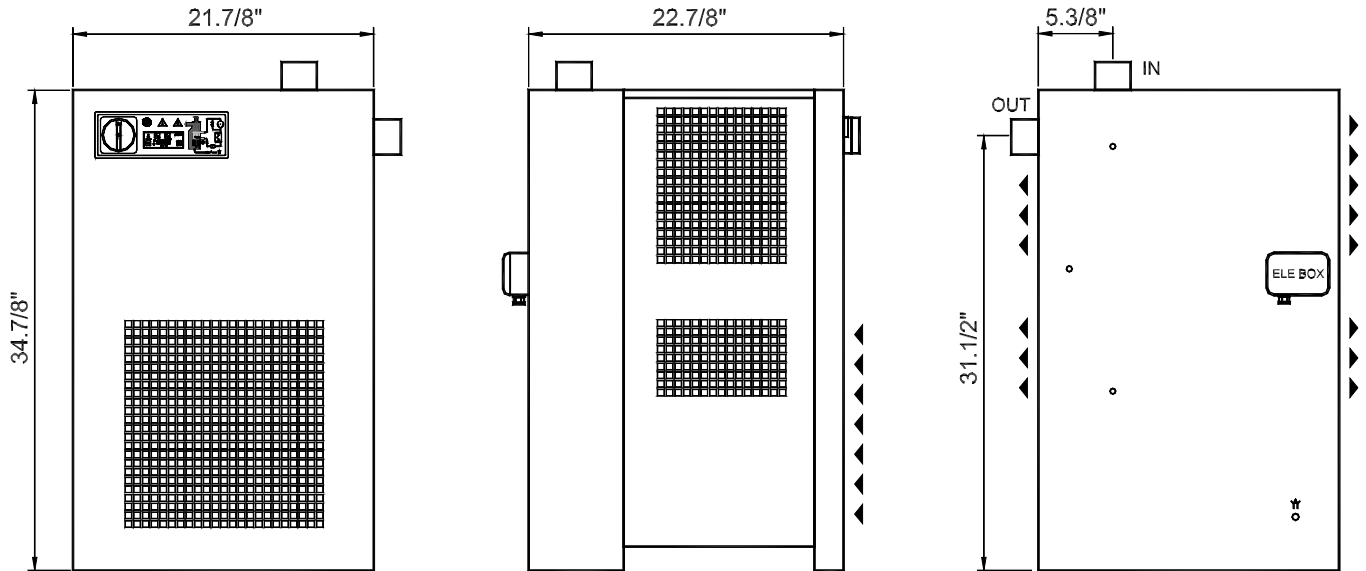

MODEL	ACT200-2
Air flow at nominal condition ¹	200 scfm
Pressure DewPoint at nominal condition ¹	38 °F
Nominal (max.) ambient temperature	100 ° F (115 °F)
Minimum ambient temperature	35 °F
Nominal (max.) inlet air temperature	100 °F (130 °F)
Nominal (max.) inlet air pressure	100psig (200psig)
Maximum outlet air pressure drop-ΔP	2.3 psi
Inlet-Outlet air connection	1.1/2" NPT-F
Refrigerant - Charge	R404A - 27 oz.
Cooling air fan flow	530 cfm
Heat Load	11900 Btu/h
Voltage	230/1/60
Nominal refrigeration compressor power	5/8 HP
Nominal electrical consumption	1200W - 5.4A
Maximum electrical consumption	1400W - 6.5A
Maximum noise level	< 70dbA at 1m
Weight net - gross	125 - 145 lbs

¹ The nominal condition refers to ambient temperature of 100°F with inlet air 100 psig and 100°F

Correction factor for operating pressure changes:									
Inlet air pressure	psig	60	80	100	120	140	160	180	200
Correction Factor		0.80	0.91	1.00	1.08	1.14	1.18	1.21	1.22

Correction factor for ambient temperature changes:							
Ambient temperature	°F	80	90	100	105	110	115
Correction Factor		1.17	1.12	1.00	0.92	0.83	0.72

Correction factor for inlet air temperature changes:							
Air temperature	°F	90	100	105	110	120	130
Correction Factor		1.22	1.00	0.89	0.79	0.63	0.50

Correction factor for DewPoint changes:					
DewPoint	°F	33-39	40-44	45-49	50-54
Correction Factor		1.00	1.09	1.22	1.40

5.1 CONTROL PANEL ACT20-ACT150

The control panel depicted below is the only operator interface

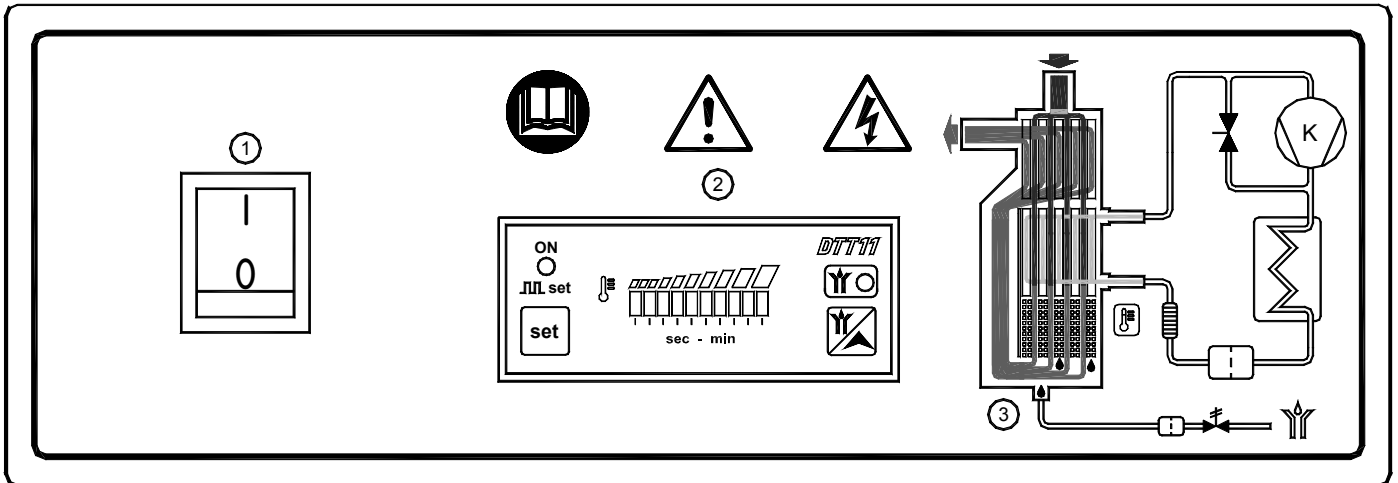

- | | | | |
|---|--|---|--|
| 1 | Rocker Switch On/Off (Illuminated when on) | 3 | Air and refrigeration gas flow diagram |
| 2 | DTT11 Air Dryer Controller | | |

5.2 CONTROL PANEL ACT200

The control panel depicted below is the only operator interface

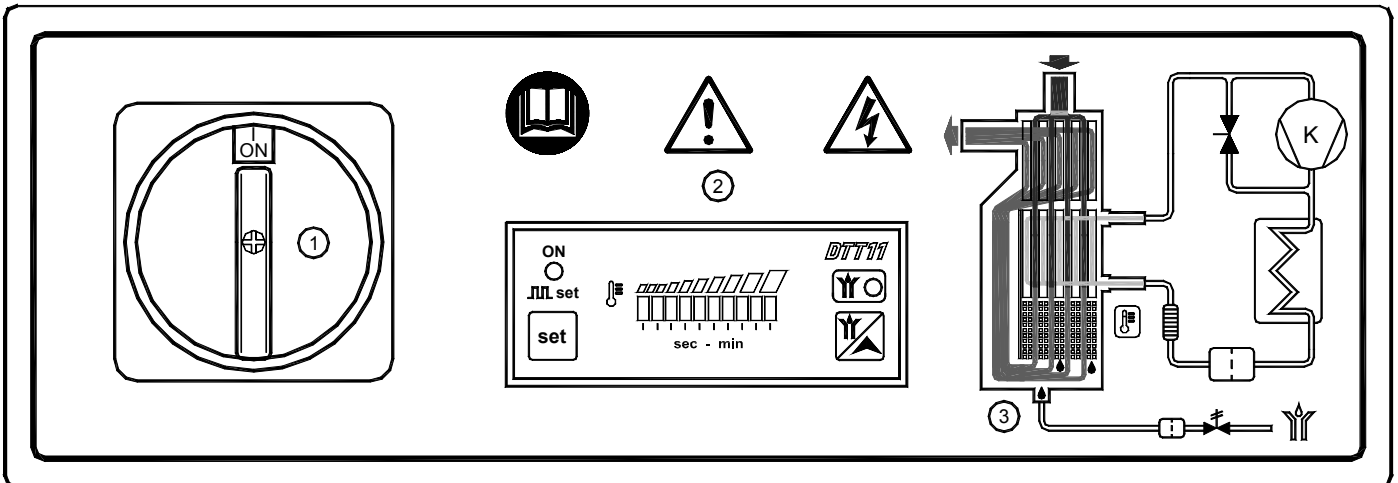

- | | | | |
|---|----------------------------|---|--|
| 1 | Rotary Switch | 3 | Air and refrigeration gas flow diagram |
| 2 | DTT11 Air Dryer Controller | | |

5.3 OPERATION

Operating principal - The dryer models described in this manual operate all on the same principal. The hot moisture laden air enters an air to air heat exchanger. The air then goes through the evaporator, also known as the air to refrigerant heat exchanger. The temperature of the air is reduced to approximately 35-39 degrees Fahrenheit, causing water vapor to condense to liquid. The liquid is continuously coalesced and collected in the separator for removal by the condensate drain. The cool moisture free air then passes back through the air to air heat exchanger to be reheated to within fifteen degrees of the incoming air temperature as it exits the dryer.

Refrigerant circuit - Refrigerant (ACT20 through ACT100=R134.a, ACT125 through ACT 200=R404A) gas is cycled through the compressor and exits at high pressure to an air condenser where heat is removed causing the refrigerant to condense to a high-pressure liquid state. The liquid is forced through a metering device (capillary tube or thermal expansion valve) where the resulting pressure drop allows the refrigerant to boil off at a predetermined temperature. Low-pressure liquid refrigerant enters the heat exchanger where heat from the incoming air is transferred causing the refrigerant to boil; the resulting phase change produces a low pressure, low temperature gas. The low-pressure gas is returned to the compressor, where it is re-compressed and begins the cycle again. During those periods when the compressed air load is reduced the excess refrigerant is by-passed automatically back to the compressor via the hot gas by-pass valve circuit.

5.4 AIR/REFRIGERANT FLOW DIAGRAM ACT20-200

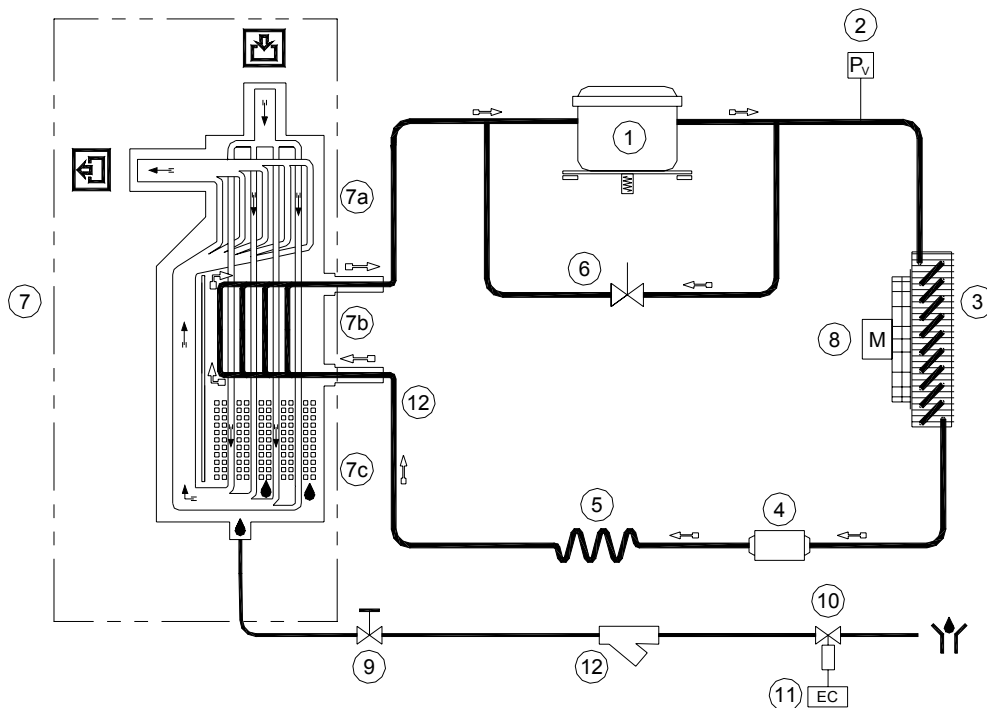

- | | |
|--|------------------------------------|
| 1 Refrigeration Compressor | 7b Air-to-refrigerant exchanger |
| 2 Refrigerant Fan Pressure Switch P _v | 7c Condensate separator |
| 3 Air Condenser | 8 Condenser fan assembly |
| 4 Filter Drier | 9 Condensate drain isolation valve |
| 5 Capillary Tube | 10 Condensate drain solenoid valve |
| 6 Constant Pressure By-pass Valve | 11 Air Dryer Controller |
| 7 ACT Heat Exchanger Module | 12 Condensate drain strainer |
| 7a Air to air heat exchanger | |

⇒ Air flow direction

⇒ Refrigerating gas flow direction

5.5 REFRIGERATION COMPRESSOR

The refrigeration compressor is the pump in the system, gas coming from the evaporator (low pressure side) is compressed up to the condensation pressure (high pressure side). The compressors utilized are manufactured by leading manufacturers and are designed for applications where high compression ratios and wide temperature changes are present. The hermetically sealed construction is perfectly gas tight, ensuring high-energy efficiency and long, useful life. Dumping springs support the pumping unit in order to reduce the acoustic emission and the vibration diffusion. The aspirated refrigeration gas, flowing through the coils before reaching the compression cylinders cools the electric motor. The thermal protection protects the compressor from over heating and over currents. The protection is automatically restored as soon as the nominal temperature conditions are reached.

5.6 CONDENSER UNIT

The condenser is the component in which the gas coming from the compressor is cooled down and condensed becoming a liquid. Mechanically, a serpentine copper tubing circuit (with the gas flowing inside) is encapsulated in an aluminium fin package. The cooling operation occurs via a high efficiency fan, creating airflow within the dryer, moving air through the fin package. It's mandatory that the ambient air temperature does not exceed the nominal values. It is also important **TO KEEP THE CONDENSER UNIT FREE FROM DUST AND OTHER IMPURITIES.**

5.7 FILTER DRIER

Traces of humidity and slag can accumulate inside the refrigeration circuit. Long periods of use can also produce sludge. This can limit the lubrication efficiency of the compressor and clog the expansion valve or capillary tube. The function of the filter drier, located before the capillary tubing, is to eliminate any impurities from circulating through the system.

5.8 CAPILLARY TUBE

It consists of a piece of reduced cross section copper tubing located between the condenser and the evaporator, acting as a metering device to reduce the pressure of the refrigerant. Reduction of pressure is a design function to achieve optimum temperature reached within the evaporator: the smaller the capillary tube outlet pressure, the lower the evaporation temperature.

The length and interior diameter of the capillary tubing is accurately sized to establish the performance of the dryer; no maintenance or adjustment is necessary.

5.9 ACT HEAT EXCHANGER MODULE

The heat exchanger module houses the air-to-air, the air-to-refrigerant heat exchangers and the demister type condensate separator. The counter flow of compressed air in the air-to-air heat exchanger ensures maximum heat transfer. The generous cross section of flow channel within the heat exchanger module leads to low velocities and reduced power requirements. The generous dimensions of the air-to-refrigerant heat exchanger plus the counter flow gas flow allows full and complete evaporation of the refrigerant (preventing liquid return to the compressor). The high efficiency condensate separator is located within the heat exchanger module. No maintenance is required and the coalescing effect results in a high degree of moisture separation.

5.10 HOT GAS BY-PASS VALVE

This valve injects a portion of the hot gas taken from the discharge side of the compressor. As needed, hot gas is injected into the return side between the evaporator and the suction port of the compressor, keeping the evaporation temperature/pressure constant at approx. 36°F. This injection prevents the formation of ice build-up inside the dryer evaporator at every load condition.



ADJUSTMENT

The hot gas by-pass valve is adjusted during the manufacturing/testing phase. As a rule no adjustment is required; If it is necessary, a qualified refrigeration technician must carry out the operation.

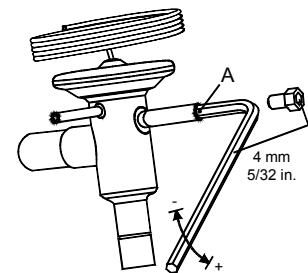





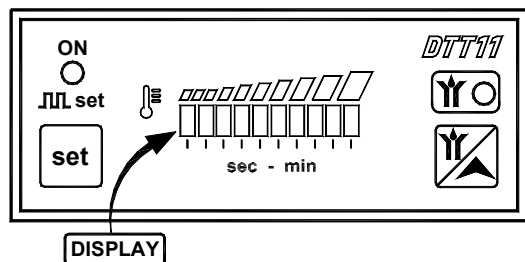

5.11 REFRIGERANT PRESSURE SWITCH PA - PB - PV

To provide operational protection, pressure switches are installed in the refrigeration circuit. Refer to exploded view diagrams for application of pressure switches on individual models.

- PB :** Low-pressure sensing device on the discharge (high-pressure) side of the compressor is activated when the pressure drops below the pre-set value. Electrical continuity is interrupted and the unit is disabled until nominal conditions are restored.
 Calibrated pressure : R 404 A Activate 15 psig – Unit Restart 73 psig
- PA :** High-pressure sensing device on the discharge (high-pressure) side of the compressor is activated when the pressure exceeds the pre-set value. Electrical continuity is interrupted and the unit is disabled. Depressing a manual-reset button mounted on the controller itself restores operation.
 Calibrated pressure : R 404 A Activate 440 psig - Manual reset
- PV :** Fan pressure switch is located on the discharge side of the compressor. At upper limit, continuity is restored to the condenser fan. At lower limit continuity is interrupted. Condenser temperature/pressure remains constant within preset limits.
 Calibrated pressure : R 134.a Upper Limit 160 psig (117°F) – Lower Limit 116 psig (97°F) - Tolerance ± 15 psi
 R 404 A Upper Limit 290 psig (113°F) – Lower Limit 232 psig (97°F) - Tolerance ± 15 psi

5.12 ELECTRONIC INSTRUMENT DTT11 (DIGITAL TIMER THERMOMETER)





-  Button - Access to set-up.
-  Button - Condensate drain test / value increment.
-  LED - Illuminated = power on.
-  LED - Flashing = set-up condition.
-  LED - Condensate drain solenoid valve on.

The DTT11 controller performs a double function: it shows the current operating DewPoint through the digital L.E.D. display and it controls the function of the condensate drain solenoid valve through the cyclic electronic timer.

OPERATION - During the dryer operation, the LED  is on. The LED bar graph display indicates the current operating DewPoint, shown by means of a three-color (blue-green-red) bar graph over the display.

- Blue section - the operating DewPoint of the dryer is too low;
- Green section - operating conditions are within the optimal DewPoint;
- Red section - DewPoint exceeds optimal conditions, compressed air treatment may be insufficient.





The factory setting for the condensate drain solenoid valve duration is 2 seconds (T_{ON}) -  LED on - Factory setting for drain interval is one minute (T_{OFF}). To manually test the condensate drain, press the  button.



Intermittent flashing of the first or last LED on the display indicates an "out of scale" condition. Exceeding the upper or lower temperature limit causes this. Intermittent flashing of both the first and last LED indicates problems with the temperature probe.





SET-UP - The DTT11 is factory set during final test of the dryer. If necessary, the user can change certain programmed parameters to affect the dryer's operation.

The parameters that can be user defined are as follows:

- T_{ON} - condensate drain solenoid valve duration time.
- T_{OFF} - drain interval time, period of time between two condensate drain solenoid activation's.

To access the set-up mode, depress the  button for at least 2 seconds; the  LED and  will flash simultaneously to confirm the first setup mode. To access the next parameter, press the  button.

To change the value of the selected parameter, depress the  button and  button simultaneously; the current value is shown on the LED display. Refer to the following table for range value and the resolution (value of each LED):

Parameter	Description	Display	Value range	Resolution	Set value
T_{ON}	Duration time of the condensate drain solenoid valve	Synchronous flashing LED  + LED 	1 - 10 sec	1 sec	2 sec
T_{OFF}	Interval time of the condensate drain solenoid valve	Non-synchronous flashing LED  + LED 	1 - 10 min	1 min	1 min

To exit the set-up mode, press the  button. The system will exit set-up mode automatically after two minutes if no operations are performed the set-up condition.

5.13 ELECTRICAL SCHEMATIC ACT 20-200 -1 115/1/60

LEGEND

CM	Compressor Motor	FPS	Fan Pressure Switch
CPR	Compressor Potential Relay	GND	Ground
CRC	Compressor Run Capacitor	PS	Power Switch
CSC	Compressor Start Capacitor	SDC	Solenoid Drain Coil
FC	Fan Start Capacitor	TOL	Thermal Overload Protection
FM	Fan Motor	TPR	Temperature Probe

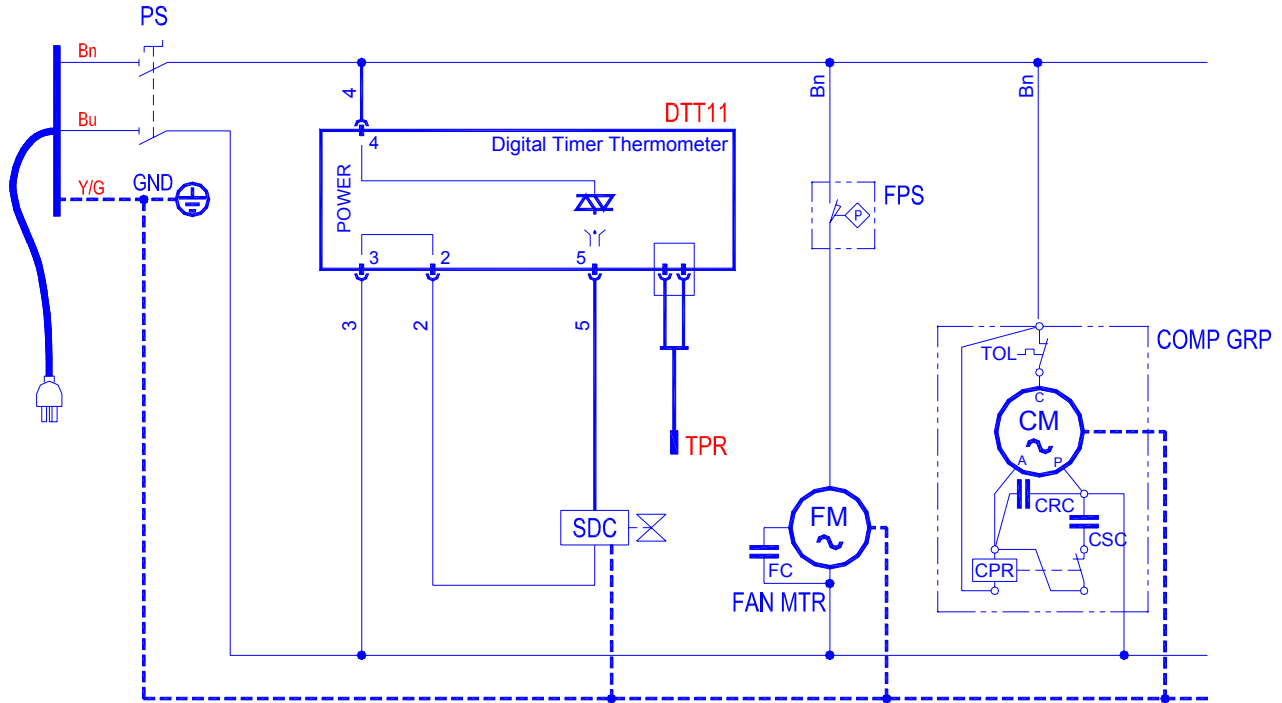

5.14 ELECTRICAL SCHEMATIC ACT 20-200 -2 230/1/60

LEGEND

CM	Compressor Motor	FPS	Fan Pressure Switch
CPR	Compressor Potential Relay	GND	Ground
CRC	Compressor Run Capacitor	PS	Power Switch
CSC	Compressor Start Capacitor	SDC	Solenoid Drain Coil
FC	Fan Start Capacitor	TOL	Thermal Overload Protection
FM	Fan Motor	TPR	Temperature Probe

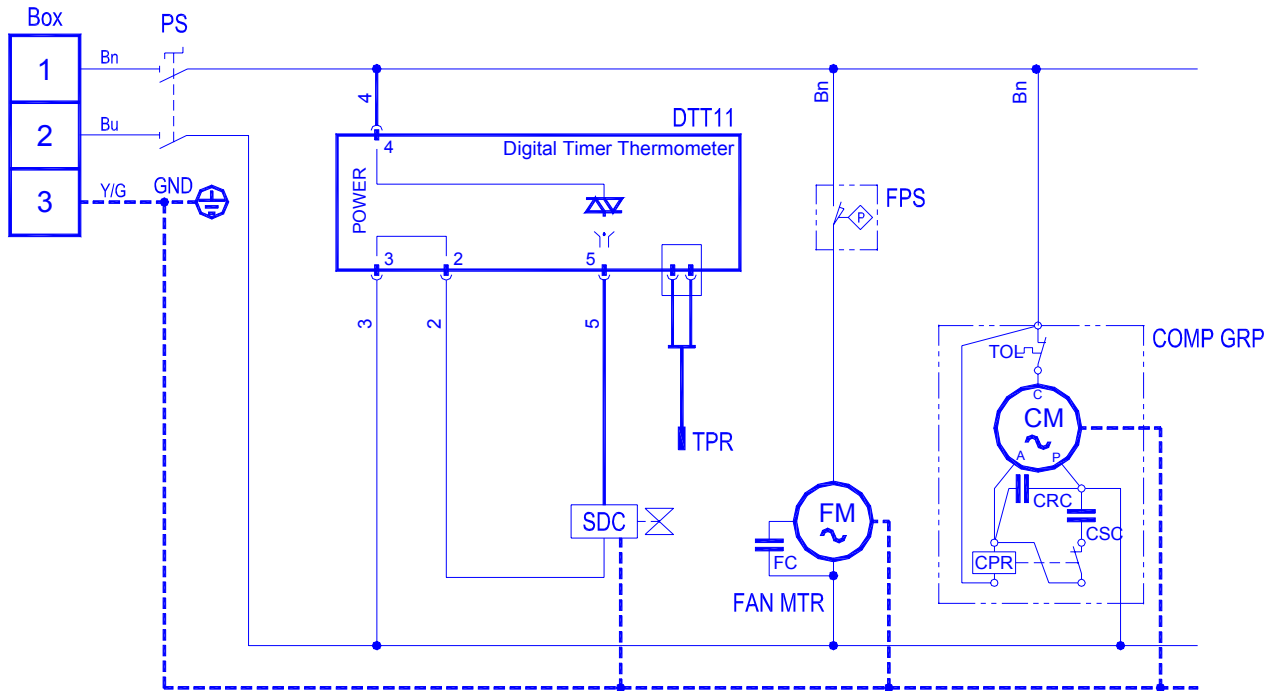

6.1 MAINTENANCE SCHEDULE



Only qualified personnel should perform maintenance operations.

Prior to performing any maintenance or service, be sure that:

- Ensure that the power is off and the unit is at atmospheric pressure.
- Main power circuit breaker is in the off position per lock out/tag out procedures.
- Ensure that maintenance personnel have read and understand the safety and operation instructions in this manual.



High temperature conditions exist during operation of system. Avoid contact until system or component has dissipated heat.



DAILY

- Verify that the DewPoint displayed on the DTT11 is within normal operating parameters.
- Check the proper operation of the condensate drain system.
- Inspect the condenser for cleanliness.



EVERY 200 HOURS OR MONTHLY

- Blow entire unit out with compressed air (Max. 30 psig)
- Blow air condenser coils out with compressed air.
- Close the isolation valve for the condensate drain, remove the mechanical filter and clean it with compressed air and a brush. Reinstall the filter, make sure it is secure, and open the isolation valve.
- Verify operation of the machine.



EVERY 1000 HOURS OR YEARLY

- Tighten all electrical connections. Inspect unit for broken, cracked or bare wires.
- Inspect refrigeration circuit for signs of oil and refrigerant leakage.
- Measure and record amperage. Verify that readings are within acceptable parameters as listed in specification table.
- Inspect condensate drain flexible hoses, and replace if necessary.
- Verify operation of the machine.

6.2 REPLACEMENT PARTS

◆ *Suggested spare part*

DESCRIPTION	Part Number	ACT (115/1/60)			
		20-1	30-1	50-1	75-1
Heat Exchange Module-ACT	5828RHN110	1	1	1	
Heat Exchange Module-ACT	5828RHN120				1
Insulation Capsule-Heat Exchanger	6025RHE010	1	1	1	
Insulation Capsule-Heat Exchanger	6025RHE020				1
Fan Motor	5210135010	1	1	1	1
Fan Blade	5215000010	1	1		
Fan Blade	5215000019			1	1
Fan Guard	5225000010			1	1
Fan Motor Mounting Bracket	5226000005	1	1		
Power Switch-Illuminated	5450SZN010	1	1	1	1
Protective Boot-Power Switch	5450SZN015	1	1	1	1
DTT11 Controller	5620130095	1	1	1	1
DewPoint Probe-DTT11-230V	5625NNN008	1	1	1	1
Condensate Isolation/Strainer Valve Combo	64355MN012	1	1	1	
Condensate Y-Strainer	64355FF011				1
◆ Drain Solenoid Valve Body	64320FF006	1	1	1	1
◆ Drain Solenoid Valve Coil-115V	64N22MM018	1	1	1	1
Hot Gas By-pass Valve	64140SS150	1	1	1	1
Filter Drier	6650SSS007	1	1	1	1
Fan Pressure Switch	5655NNN160	1	1	1	1
Air Condenser	5810005005	1	1		
Air Condenser	5810023005			1	1
Compressor	5015135101	1			
Compressor	5015135103		1		
Compressor	5015135007			1	
Compressor	5015135010				1

◆ **Suggested spare part**

DESCRIPTION	Part Number	ACT (115/1/60)			
		20-1	30-1	50-1	75-1
Front Panel	680AC003ANDC2	1	1	1	
Front Panel	680AC018ANDC2				1
R/H Side/Top Panel	680AC003LT1C2	1	1	1	
L/H Side/Top Panel	680AC003LT2C2	1	1	1	
R/H Side/Top Panel	680AC018LT1C2				1
L/H Side/Top Panel	680AC018LT2C2				1
Rear Panel	680AC003PS1R	1	1		
Rear Panel	680AC003PSTR			1	
Rear Panel	680AC018PSTR				1
Base Panel	680AC003P20X	1	1	1	
Base Panel	680AC018S21X				1
Exterior Panel Mounting Support	680AC003S22X	1	1	1	
Exterior Panel Mounting Support	680AC018S04X				1
Pressure Control Mounting Bracket	680AC018S03X				1
Component Shelf	680AC018S20X				1

◆ **Suggested spare part**

DESCRIPTION	Part Number	ACT (230/1/60)			
		20-2	30-2	50-2	75-2
Heat Exchange Module-ACT	5828RHN110	1	1	1	
Heat Exchange Module-ACT	5828RHN120				1
Insulation Capsule-Heat Exchanger	6025RHE010	1	1	1	
Insulation Capsule-Heat Exchanger	6025RHE020				1
Fan Motor	5210110005	1	1		
Fan Motor	5210110011			1	
Fan Motor	5210110012				1
Fan Blade	5215000010	1	1		
Fan Blade	5215000019			1	1
Fan Guard	5225000010			1	1
Power Switch-Illuminated	5450SZN010	1	1	1	1
Protective Boot-Power Switch	5450SZN015	1	1	1	1
DTT11 Controller-230V	5620110095	1	1	1	1
DewPoint Probe-DTT11	5625NNN008	1	1	1	1
Condensate Isolation/Strainer Valve Combo	64355MN012	1	1	1	
Condensate Y-Strainer	64355FF011				1
◆ Drain Solenoid Valve Body	64320FF006	1	1	1	1
◆ Drain Solenoid Valve Coil 230V	64N22MM021	1	1	1	1
Hot Gas By-pass Valve	64140SS150	1	1	1	1
Filter Drier	6650SSS007	1	1	1	1
Fan Pressure Switch	5655NNN160	1	1	1	1
Air Condenser	5810005005	1	1		
Air Condenser	5810023005			1	1
Compressor	5015110101	1			
Compressor	5015110104		1		
Compressor	5015110113			1	
Compressor	5015110115				1

◆ *Suggested spare part*

DESCRIPTION	Part Number	ACT (230/1/60)			
		20-2	30-2	50-2	75-2
Front Panel	680AC003ANDC2	1	1	1	
Front Panel	680AC018ANDC2				1
R/H Side/Top Panel	680AC003LT1C2	1	1	1	
L/H Side/Top Panel	680AC003LT2C2	1	1	1	
R/H Side/Top Panel	680AC018LT1C2				1
L/H Side/Top Panel	680AC018LT2C2				1
Rear Panel	680AC003PS1R	1	1		
Rear Panel	680AC003PSTR			1	
Rear Panel	680AC018PSTR				1
Base Panel	680AC003P20X	1	1	1	
Base Panel	680AC018S21X				1
Exterior Panel Mounting Support	680AC003S22X	1	1	1	
Exterior Panel Mounting Support	680AC018S04X				1
Pressure Control Mounting Bracket	680AC018S03X				1
Component Shelf	680AC018S20X				1

◆ **Suggested spare part**

DESCRIPTION	Part Number	ACT (115/1/60)			
		100-1	125-1	150-1	200-1
Heat Exchange Module-ACT	5828RHN130	1	1	1	
Heat Exchange Module-ACT	5828RHN140				1
Insulation Capsule-Heat Exchanger	6025RHE030	1	1	1	
Insulation Capsule-Heat Exchanger	6025RHE040				1
Fan Motor	5210135020	1	1	1	
Fan Motor	5210135021				1
Fan Blade	5215000025	1	1	1	
Fan Blade	5215000035				1
Fan Guard	5225000027	1	1	1	
Fan Guard	5225000030				1
Power Switch-Illuminated	5450SZN010	1	1	1	
Protective Boot-Power Switch	5450SZN015	1	1	1	
Contact Block-Rotary Switch	5450SZN112				1
Rotary Power Switch	5450SZN116				1
DTT11 Controller	5620130095	1	1	1	1
DewPoint Probe-DTT11	5625NNN008	1	1	1	1
Condensate Y-Strainer	64355FF011	1	1	1	1
Drain Solenoid Valve Body	64320FF006	1	1	1	
Drain Solenoid Valve Body	64320FF011				1
Drain Solenoid Valve Coil-115V	64N22MM018	1	1	1	1
Hot Gas By-pass Valve	64140SS150	1			
Hot Gas By-pass Valve	64140SS155		1	1	1
Filter Drier	6650SSS007	1			
Filter Drier	6650SSN150		1	1	
Filter Drier	6650SSN160				1
Fan Pressure Switch	5655NNN160	1	1	1	1
Air Condenser	5810030007	1			
Air Condenser	5810020005		1		
Air Condenser	5810030005			1	
Air Condenser	5810052005				1

◆ *Suggested spare part*

DESCRIPTION	Part Number	ACT (115/1/60)			
		100-1	125-1	150-1	200-1
Compressor	5015135011	1			
Compressor	5025135003		1	1	
Compressor	5025135005				1
Front Panel	680AC030ANDC2	1			
Front Panel	680AC040ANDC2		1	1	
Front Panel	680AC055ANDC2				1
R/H Side/Top Panel	680AC018LT1C2	1	1	1	
L/H Side/Top Panel	680AC018LT2C2	1	1	1	
Side Panel	680AC055LTRC2				2
Rear Panel	680AC018PSTR	1	1	1	
Rear Panel	680AC055PSTR				1
Top Panel	680AC055CPRC2				1
Base Panel	680AC018S21X	1	1	1	
Base Panel	680AC055S21X				1
Exterior Panel Mounting Support	680AC018S04X	1	1	1	
Pressure Control Mounting Bracket	680AC018S03X	1	1	1	1
Component Shelf	680AC018S20X	1	1	1	
Component Shelf	680AC055S20X				1
Component Shelf Support	680AC055S01X				2

◆ **Suggested spare part**

DESCRIPTION	Part Number	ACT (230/1/60)			
		100-2	125-2	150-2	200-2
Heat Exchange Module-ACT	5828RHN130	1	1	1	
Heat Exchange Module-ACT	5828RHN140				1
Insulation Capsule-Heat Exchanger	6025RHE030	1	1	1	
Insulation Capsule-Heat Exchanger	6025RHE040				1
Fan Motor	5210110018	1	1	1	
Fan Motor	5210110022				1
Fan Blade	5215000025	1	1	1	
Fan Blade	5215000035				1
Fan Guard	5225000027	1	1	1	
Fan Guard	5225000030				1
Power Switch-Illuminated	5450SZN010	1	1	1	
Protective Boot-Power Switch	5450SZN015	1	1	1	
Contact Block-Rotary Switch	5450SZN112				1
Rotary Power Switch	5450SZN116				1
DTT11 Controller	5620110095	1	1	1	1
DewPoint Probe-DTT11	5625NNN008	1	1	1	1
Condensate Y-Strainer	64355FF011	1	1	1	1
Drain Solenoid Valve Body	64320FF006	1	1	1	
Drain Solenoid Valve Body	64320FF011				1
Drain Solenoid Valve Coil-230V	64N22MM021	1	1	1	1
Hot Gas By-pass Valve	64140SS150	1			
Hot Gas By-pass Valve	64140SS155		1	1	1
Filter Drier	6650SSS007	1			
Filter Drier	6650SSN150		1	1	
Filter Drier	6650SSN160				1
Fan Pressure Switch	5655NNN160	1	1	1	1
Air Condenser	5810030007	1			
Air Condenser	5810020005		1		
Air Condenser	5810030005			1	
Air Condenser	5810052005				1

◆ *Suggested spare part*

DESCRIPTION	Part Number	ACT (230/1/60)			
		100-2	125-2	150-2	200-2
Compressor	5015110016	1			
Compressor	5025115003		1	1	
Compressor	5025115006				1
Front Panel	680AC030ANDC2	1			
Front Panel	680AC040ANDC2		1	1	
Front Panel	680AC055ANDC2				1
R/H Side/Top Panel	680AC018LT1C2	1	1	1	
L/H Side/Top Panel	680AC018LT2C2	1	1	1	
Side Panel	680AC055LTRC2				2
Rear Panel	680AC018PSTR	1	1	1	
Rear Panel	680AC055PSTR				1
Top Panel	680AC055CPRC2				1
Base Panel	680AC018S21X	1	1	1	
Base Panel	680AC055S21X				1
Exterior Panel Mounting Support	680AC018S04X	1	1	1	
Pressure Control Mounting Bracket	680AC018S03X	1	1	1	1
Component Shelf	680AC018S20X	1	1	1	
Component Shelf	680AC055S20X				1
Component Shelf Support	680AC055S01X				2

7.1 TROUBLESHOOTING



Only qualified personnel should perform maintenance operations.

Prior to performing any maintenance or service, be sure that:

- **Ensure that the power is off and the unit is at atmospheric pressure.**
- **Main power circuit breaker is in the off position per lock out/tag out procedures.**
- **Ensure that maintenance personnel have read and understand the safety and operations instructions in this manual.**
- **High temperature conditions exist during operation of system. Avoid contact until system or component has dissipated heat.**

SYMPTOM

POSSIBLE CAUSE - SUGGESTED ACTION

- | | |
|---|---|
| <p>◆Dryer does not start</p> | <p>⇒ Check main power supply</p> <p>⇒ Verify electrical wiring connections</p> |
| <p>◆Refrigeration compressor is not running</p> | <p>⇒ Activation of compressor thermal overload protection-wait 30 minutes and retry. If thermal overload protection has repeated occurrences, consult factory</p> <p>⇒ Verify electrical wiring connections</p> |
| <p>◆The condenser fan is inoperable
(note: fan cycles on units w/pressure switches)</p> | <p>⇒ Verify electrical wiring connections</p> <p>⇒ Fan pressure switch is faulty, bypass pressure switch and verify fan motor operation. Replace pressure switch if fan runs.</p> |
| <p>◆DewPoint exceeds upper limit</p> | <p>⇒ Verify dryer is in the on position</p> <p>⇒ The DewPoint sensor is not accurately reading the temperature-ensure probe is properly seated in the bottom of the thermowell</p> <p>⇒ The refrigeration compressor is not operating properly-see specific point</p> <p>⇒ Ambient temperature exceeds acceptable levels or unit is not properly ventilated. Take measures to reduce room temperature or increase ventilation.</p> <p>⇒ Inlet air is too hot, restore inlet air temperature to nominal conditions</p> <p>⇒ Inlet air pressure is too low resulting in increased load, raise air pressure to nominal conditions.</p> <p>⇒ Inlet air flow exceeds dryer rating, reduce flow to stated nominal conditions</p> <p>⇒ Air condenser is dirty, restricting flow of cooling air, clean condenser</p> <p>⇒ The condenser cooling fan is inoperable-see specific point</p> <p>⇒ Condensate drain is inoperable-see specific point</p> <p>⇒ The hot-gas by-pass valve may need adjustment-contact a refrigeration tech.</p> <p>⇒ Leak in the refrigeration circuit-contact a refrigeration tech.</p> |
| <p>◆DewPoint exceeds lower limit</p> | <p>⇒ The condenser cooling fan runs continuously -Pv pressure switch is faulty</p> <p>⇒ The hot-gas by-pass valve may need adjustment-contact a refrigeration tech.</p> <p>⇒ The DewPoint sensor is not accurately reading the temperature-ensure probe is properly seated in the bottom of the thermowell</p> |
| <p>◆Excessive pressure drop</p> | <p>⇒ DewPoint is too low, ice build up in the heat exchanger restricting air flow-see specific point</p> <p>⇒ Check for restrictions in air system before and after dryer</p> <p>⇒ Condensate drain not functioning properly-see specific point</p> |

- ◆ Condensate drain does not open-no condensate discharged
 - ⇒ Isolation valve is closed-open valve
 - ⇒ Verify electrical connections
 - ⇒ Solenoid valve body has debris in it. – Disassemble and clean orifice
- ◆ Condensate drain does not open- no condensate discharged cont'd
 - ⇒ Solenoid valve coil is inoperable-test, replace if necessary
 - ⇒ The DewPoint is too low-heat exchanger is frozen-see specific point
 - ⇒ DTT11-The DTT11 drain function is inoperable-replace
- ◆ Condensate drain is continuously open
 - ⇒ Solenoid valve body has debris in it. – Disassemble and clean orifice
 - ⇒ Try to remove the electric connector on the solenoid valve - if drain stop the DTT11 electronic instrument is faulty – replace it.

8.1 EXPLODED VIEW-TABLE OF COMPONENTS

Exploded view table of components

1 ACT Heat Exchanger Module	11 Fan guard	21 Top Panel
2 Panel support bracket	12 Fan motor	22 Refrigerant pressure switch P _A
3 Side panel	13 Filter Drier	23 Refrigerant pressure switch P _B
4 Hot gas by-pass valve	14 Solenoid valve body -Cond. Drain	24 Fan
5 Refrigerant pressure switch P _V	15 Solenoid valve coil -Cond. Drain	25 Isolation valve / Strainer
6 Control panel	16 Isolation valve / Strainer	26 Zero Loss Drain-Optional
7 Front panel	17 Base panel	
8 Refrigeration compressor	18 Condenser	
9 Capillary tube	19 Rear panel	
10 Fan blade	20 Component Shelf	

ACT 20 – ACT 50

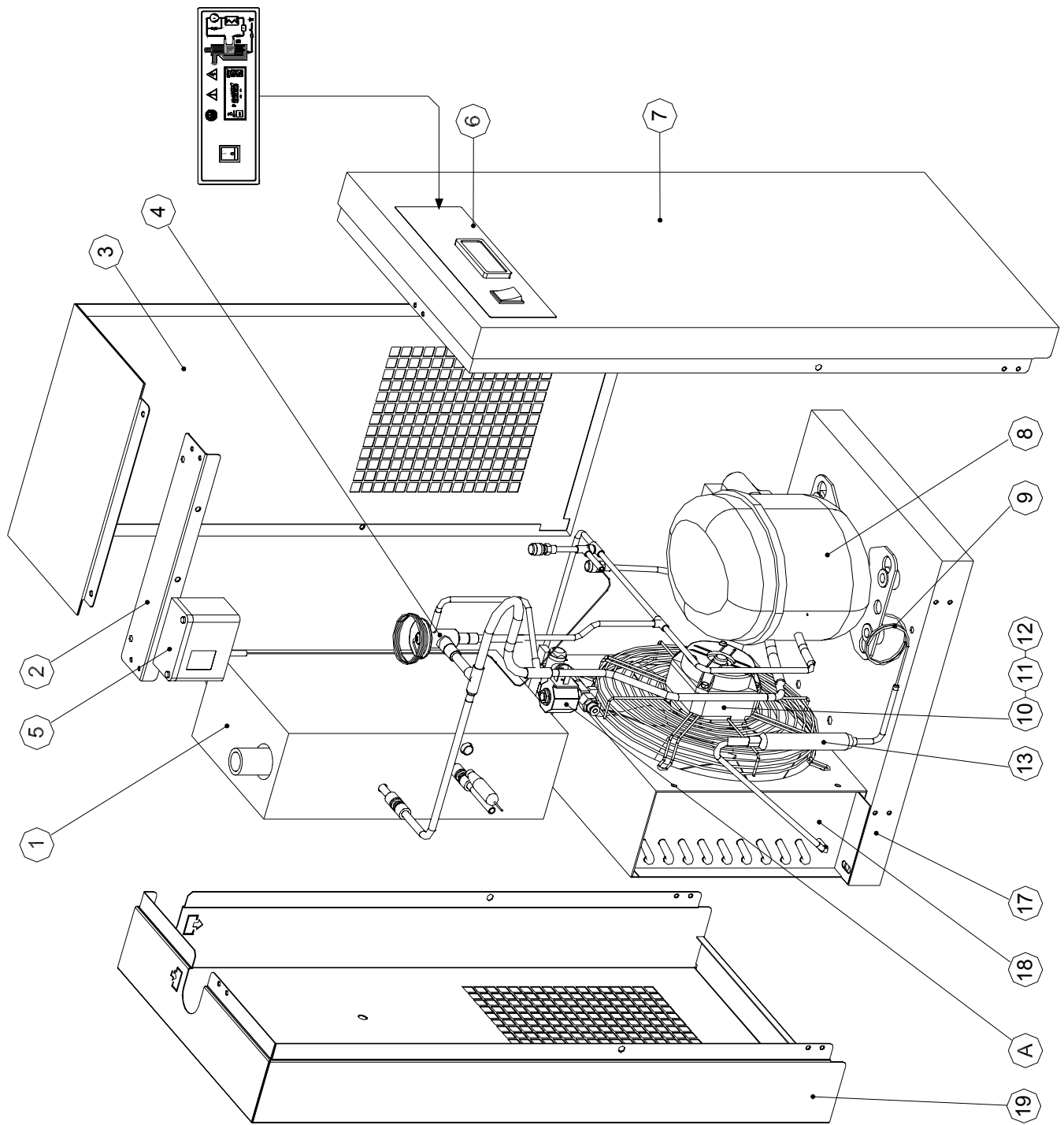

Pos. A
STANDARD

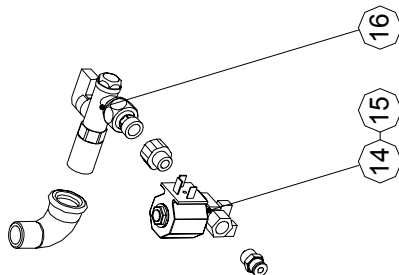

Pos. A
OPTIONAL

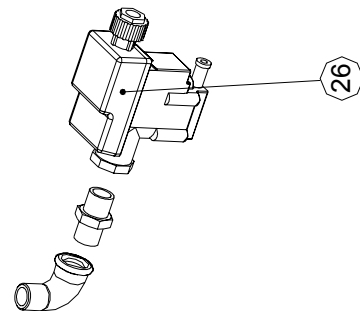

ACT 75

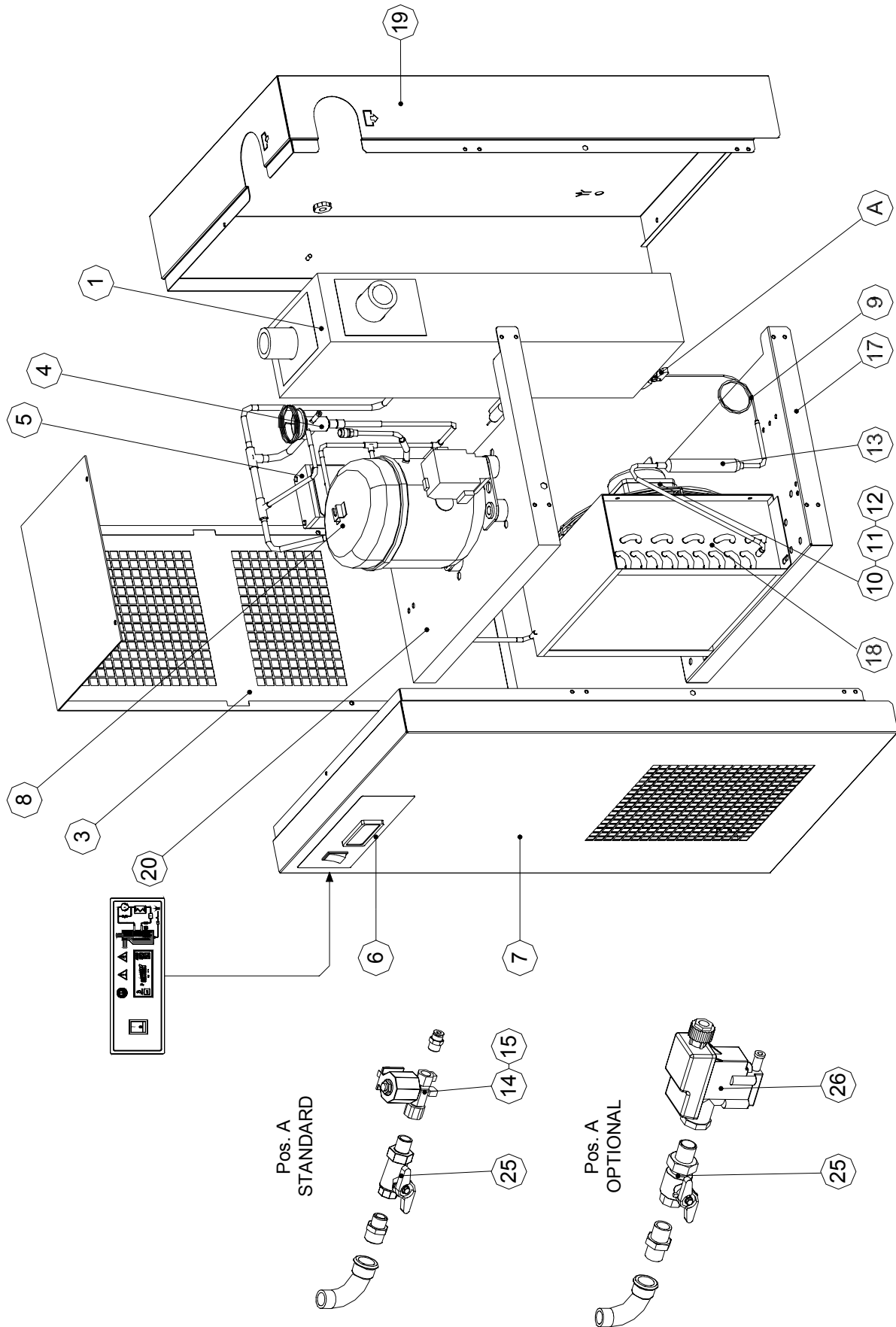

ACT 100 – ACT 150

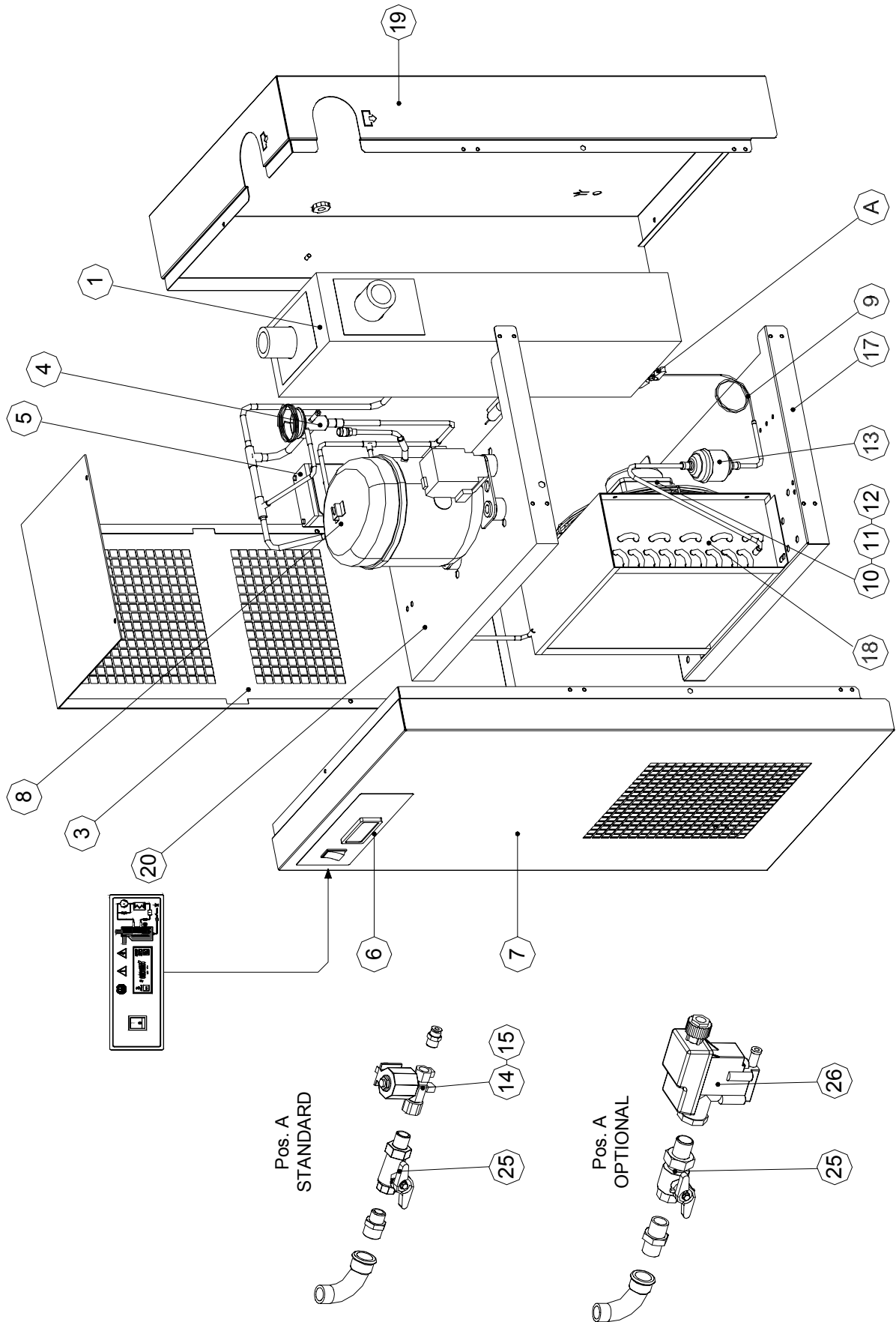

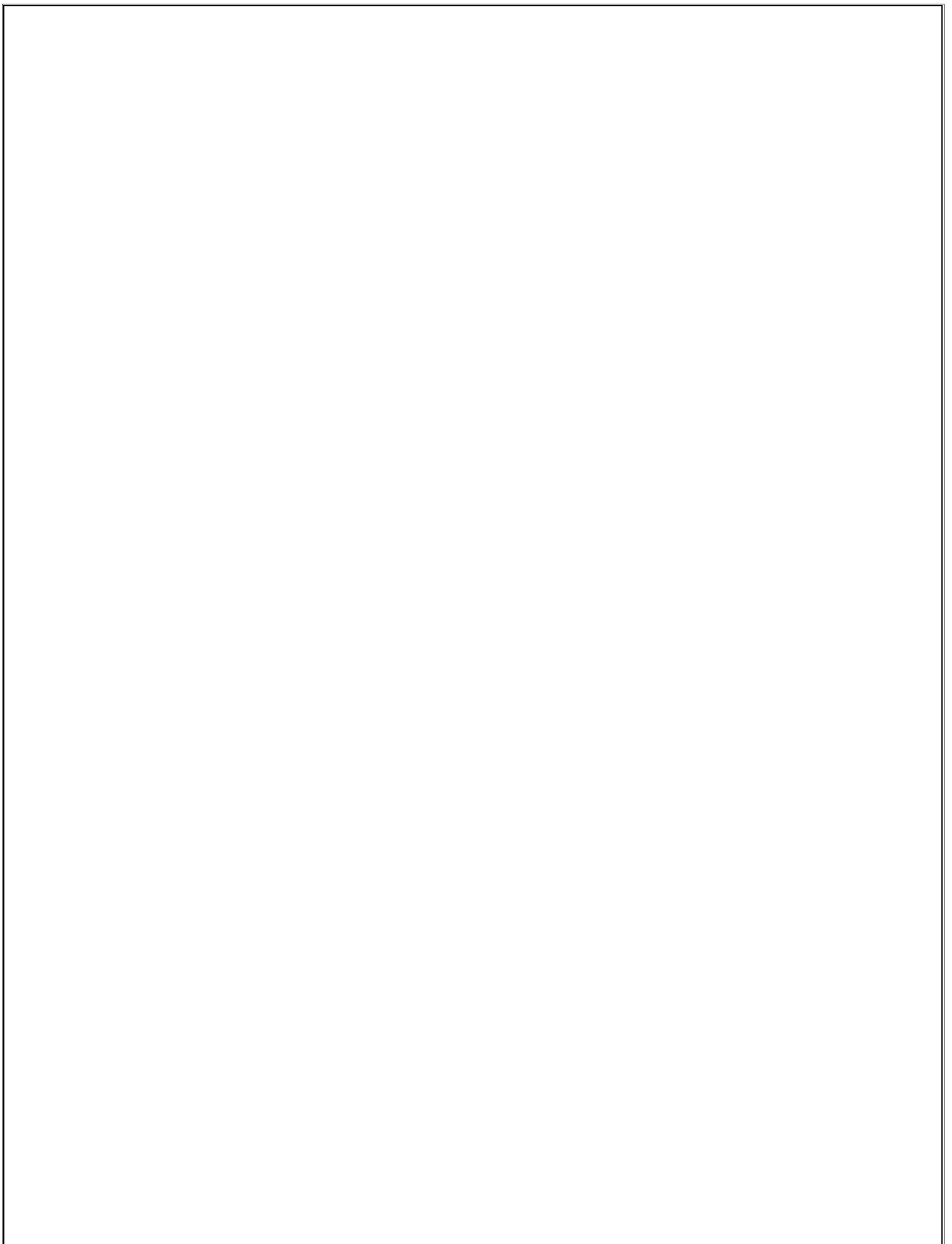



149 Rickey Blvd., Bear, Delaware • TEL. (302) 832-5800 • FAX (302) 832-5900