

BelAir

COMPRESSED AIR TREATMENT

ACT Series Refrigerated Dryers

Installation & Operation Maintenance Manual

ACT600 - ACT2000
(-4) 460/3/60

MODEL:

SERIAL NUMBER:



BELAIR TECHNOLOGIES, LLC
COLORADO OFFICE
10200 E. 106TH AVENUE
BRIGHTON, COLORADO 80601
TEL: (303) 287-6666
FAX: (720) 554-7758

DELAWARE OFFICE
149 RICKEY BLVD.
BEAR, DELAWARE 19701
TEL: (302) 832-5800
FAX: (302) 832-5900

FRIULAIR
Dryers

STATEMENT OF WARRANTY TERMS & CONDITIONS

BelAir's refrigerated air dryers are warranted to be free of defects in materials and workmanship under proper use, installation, and application. Warranty covers parts and labor at fair market value and according to warranty labor replacement guidelines. This warranty shall be for a period of 15 months from date of shipment from our factory or other stocking facilities or 12 months from date of installation. Proof of installation date will be required. All dryers outside the U.S. and Canada carry a parts only warranty.

ALL FREIGHT DAMAGE CLAIMS ARE NOT THE RESPONSIBILITY OF THE MANUFACTURER AND ARE NOT COVERED UNDER WARRANTY AS ALL PRODUCTS ARE SHIPPED F.O.B. SHIPPER.

PLEASE DIRECT ALL FREIGHT CLAIMS TO THE SHIPPER IN QUESTION.

EXCLUSIONS

ADJUSTMENTS TO THE HOT GAS AND MAINTENANCE OF FLOAT AND AUTOMATIC DRAINS AND CONDENSER COILS ARE CONSIDERED TO BE ROUTINE MAINTENANCE AND THEREFORE NON-WARRANTABLE ITEMS AND ARE THE SOLE RESPONSIBILITY OF THE END USER. CONSULT THE INSTALLATION, OPERATION AND MAINTENANCE MANUAL FOR THE ADJUSTMENT AND MAINTENANCE PROCEDURES. THE GEOMETRIC CONFIGURATION OF THE ACT HEAT EXCHANGER REQUIRES A MINIMUM 5 MICRON (1 MICRON RECOMMENDED) PREFILTER TO ENSURE THE LIFE OF THE HEAT EXCHANGER, THE PREFILTER MUST ALSO BE PROPERLY MAINTAINED.

THIS WARRANTY DOES NOT APPLY TO ANY UNIT DAMAGED BY ACCIDENT, MODIFICATION, MISUSE, NEGLIGENCE, OR MISAPPLICATION. DAMAGE TO HEAT EXCHANGERS BY EXPOSURE TO AMMONIA, ANY OTHER CORROSIVE SUBSTANCE OR SUB-FREEZING ENVIRONMENT WILL BE CONSIDERED MISUSE.

INSPECTION

Any refrigerated dryer part or material found defective will be repaired, replaced or refunded, at the sellers option free of charge, provided that BelAir is notified within the above stated warranty period. **All returns of allegedly defective equipment must have prior written authorization.** Said authorization may be obtained through our refrigerated dryer service department. All refrigerated dryers, parts, materials must be returned **freight prepaid** to the Manufacturer's factory for inspection within 30 days of return authorization date. Any shipment returned to the factory collect will be refused.

After inspection, if an item is found to be warrantable, the repaired item or replacement will be returned normal ground freight prepaid within the continental United States and Canada. In the event an item is deemed non-warranty due to improper usage, maintenance, improper installation, abuse, alteration or operator error the customer is responsible for all charges (including parts, labor or replacement costs) incurred resolving the warranty claim. Expedited shipment costs are the responsibility of the requestor.

Any replacement part or material is warranted only to the extent of the remaining warranty period of the dryer or to the extent as provided by the supplier, whichever is longer.

IDENTIFICATION PLATE

The identification plate is located on the back of the dryer and shows all the primary data of the machine. Upon installation, fill in the table on the previous page with all the data shown on the identification plate. This data should always be referred to when calling the manufacturer or distributor.

The removal or alteration of the identification plate will void the warranty rights.

DISCLAIMER

The warranty does not cover any responsibility or liability for direct or indirect damages to persons, or equipment caused by improper usage or maintenance, and is limited to manufacturing defects only. Refer to BelAir Warranty policy manual for travel, mileage and special charge considerations. The warranty will be immediately voided if there are changes or alterations to the dryer.

FILTERS AND DRAINS

Filters and drains are warranted to be free from defects in material and workmanship, under proper use, installation, application and maintenance in accordance with written specifications for a period of one year from date of purchase. Elements, o-rings and float drains are considered consumable items and are warranted at installation only.

WHO TO CONTACT IF YOU HAVE A WARRANTY CLAIM:

BelAir Technologies, LLC	Phone	(302) 832-5800	Delaware
		(303) 287-6666	Colorado
	Fax	(302) 832-5900	Delaware
		(720) 554-7758	Colorado

All freight damage claims should be filed within 15 working days and should be directed to the carrier.

TABLE OF CONTENTS

SAFETY RULES

- 1.1 Explanation of Convention Symbols Used in This Manual
- 1.2 Warnings
- 1.3 Proper Use of the Dryer

INSTALLATION

- 2.1 Transporting the Unit
- 2.2 Installation Site
- 2.3 Installation Layout & Correction Factors
- 2.4 Connection to the Compressed Air system
- 2.5 Connection to the Main Power
- 2.6 Condensate Drain

START-UP

- 3.1 Preliminary Operations
- 3.2 Initial Start-Up
- 3.3 Start-up and Shut-down

4. TECHNICAL SPECIFICATIONS

- 4.1 Technical Specifications ACT600-4 – ACT1000-4 (460/3/60)
- 4.2 Technical Specifications ACT1500-4 – ACT2000-4 (460/3/60)

5. TECHNICAL COMPONENT INFORMATION

- 5.1 Control Panel
- 5.2 Operation
- 5.3 Flow Diagram
- 5.4 Refrigeration Compressor
- 5.5 Condenser Unit
- 5.6 Filter Drier
- 5.7 Capillary Tube
- 5.8 ACT Heat Exchanger Module
- 5.9 Hot Gas By-pass Valve
- 5.10 Refrigerant Pressure Switches
- 5.11 Electronic Controller DMC12
- 5.12 Electrical Schematic ACT600-4 – ACT1000-4 (460/3/60)
- 5.13 Electrical Schematic ACT1500-4 – ACT2000-4 (460/3/60)

6. MAINTENANCE/SERVICE PARTS

- 6.1 Maintenance Schedule
- 6.2 Replacement Parts

7. TROUBLESHOOTING

- 7.1 Troubleshooting Guide

8. UNIT DRAWINGS-EXPLODED VIEWS

- 8.1 Exploded View ACT600-4 – ACT1000-4
- 8.2 Exploded View ACT1500-4 – ACT2000-4

1.1 DEFINITION OF THE SAFETY SYMBOLS



Carefully read instruction manual before attempting any service or maintenance procedures on the dryer.



Caution warning sign. Risk of danger or possibility of damage to equipment, if related text is not followed properly.



Electrical hazard. Warning message indicates practices or procedures that could result in personal injury or fatality if not followed correctly.



Danger hazard. Part or system under pressure.



Danger hazard. High temperature conditions exist during operation of system. Avoid contact until system or component has dissipated heat.



Danger hazard. Treated air is not suitable for breathing purposes; serious injury or fatality may result if precautions are not followed.



Danger hazard: In case of fire, use an approved fire extinguisher, water is not an acceptable means in cases of electrical fire



Danger hazard. Do not operate equipment with panels removed.



Maintenance or control operation to be performed by qualified personnel only ¹.



Compressed air inlet connection point.



Compressed air outlet connection point.



Condensate drain connection point.



Operations that can be performed by the operator of the machine, if qualified ¹.

NOTE: Text that specifies items of note to be taken into account does not involve safety precautions.



In designing this unit a lot of care has been devoted to environmental protection:

- CFC free refrigerants
- CFC free insulation parts
- Energy saving design
- Limited acoustic emission
- Dryer and relevant packaging composed of recyclable materials

This symbol requests that the user heed environmental considerations and abide with suggestions annotated with this symbol.

¹ Experienced and trained personnel familiar with national and local codes, capable to perform the needed activities, identify and avoid possible dangerous situations while handling, installing, using and servicing the machine. Ensuring compliance to all statutory regulations.

1.2 WARNINGS



Compressed air is a highly hazardous energy source.

Never work on the dryer with pressure in the system.

Never point the compressed air or the condensate drain outlet hoses towards anybody.

The user is responsible for the proper installation of the dryer. Failure to follow instructions given in the "Installation" chapter will void the warranty. Improper installation can create dangerous situations for personnel and/or damages to the machine could occur.



Only qualified personnel are authorized to service electrically powered devices. Before attempting maintenance, the following conditions must be satisfied :

- Ensure that main power is off, machine is locked out, tagged for service and power cannot be restored during service operations.
- Ensure that valves are shut and the air circuit is at atmospheric pressure. De-pressurize the dryer.



Warranty does not apply to any unit damaged by accident, modification, misuse, negligence or misapplication. Unauthorized alterations will immediately void the warranty.



In case of fire, use an approved fire extinguisher, water is not an acceptable means in cases of electrical fire.

1.3 PROPER USE OF THE DRYER

This dryer has been designed, manufactured and tested for the purpose of separating the humidity normally contained in compressed air. Any other use has to be considered improper.

The Manufacturer will not be responsible for any problem arising from improper use; the user will bear responsibility for any resulting damage.

Moreover, the correct use requires the adherence to the installation instructions, specifically:

- Voltage and frequency of the main power.
- Pressure, temperature and flow-rate of the inlet air.
- Ambient temperature.



The purpose of the machine is the removal of water and residual oil vapor present in compressed air. The dried air cannot be used for respiration purposes or for operations leading to direct contact with food products.

This dryer is not suitable for the treatment of dirty air or of air containing solid particles.

2.1 TRANSPORTING THE UNIT

Check for visible loss or damage, if no visible damage is found place the unit near to the installation point and unpack the contents.

- Always keep the dryer in the upright vertical position. Damage to components could result if unit is laid on its side or if placed upside down.
- Store machine in a clean, dry environment, do not expose to severe weather environments.



The packaging materials are recyclable. Dispose of material in compliance with the rules and regulations in force in the destination country.

2.2 INSTALLATION SITE



Failure to install dryer in the proper ambient conditions will affect the dryer's ability to condense refrigerant gas. This can cause higher loads on the compressor, loss of dryer efficiency and performance, overheated condenser fan motors, electrical component failure and dryer failure due to the following: compressor loss, fan motor failure and electrical component failure. Failures of this type will affect warranty considerations. Do not install dryer in an environment of corrosive chemicals, explosive gasses, poisonous gasses; steam heat, areas of high ambient conditions or extreme dust and dirt.



In case of fire, use an approved fire extinguisher, water is not an acceptable means in cases of electrical fire.

Minimum installation requirements:

- Select a clean dry area, free from dust, and protected from atmospheric disturbances.
- The supporting plate must be smooth, horizontal and able to hold the weight of the dryer.
- Minimum ambient temperature is 34°F, see data plate for maximum temperature.
- Allow at least 40 inches (3 feet for ACT 1500 to ACT 2000 models) of clearance on each side of the dryer for proper ventilation and circulation through the condenser. The space is also necessary to facilitate maintenance operations. The dryer does not require attachment to the floor surface, however installations where the unit is suspended require an attachment to the hanging apparatus.

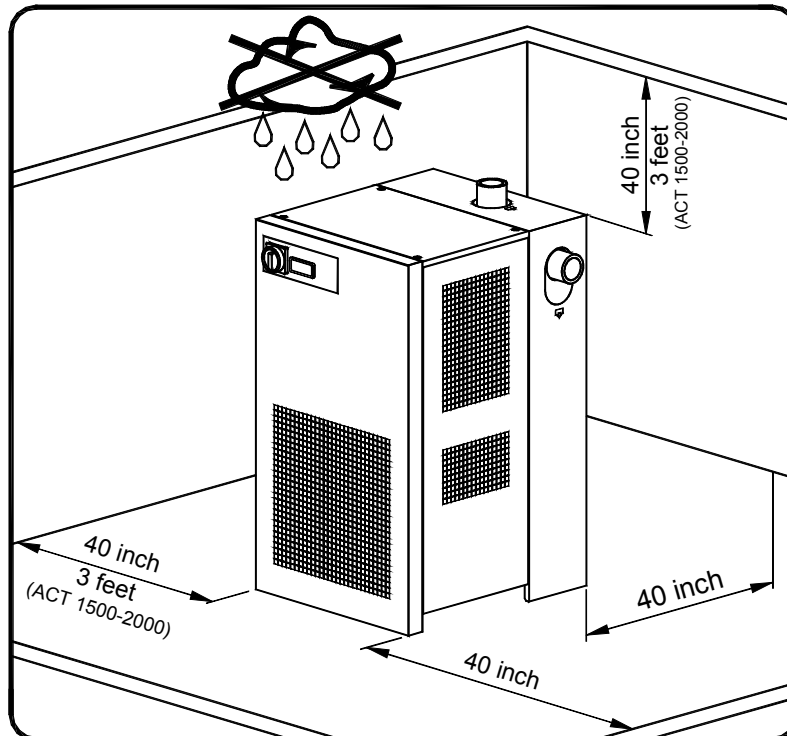

2.3 INSTALLATION LAYOUT & CORRECTION FACTORS

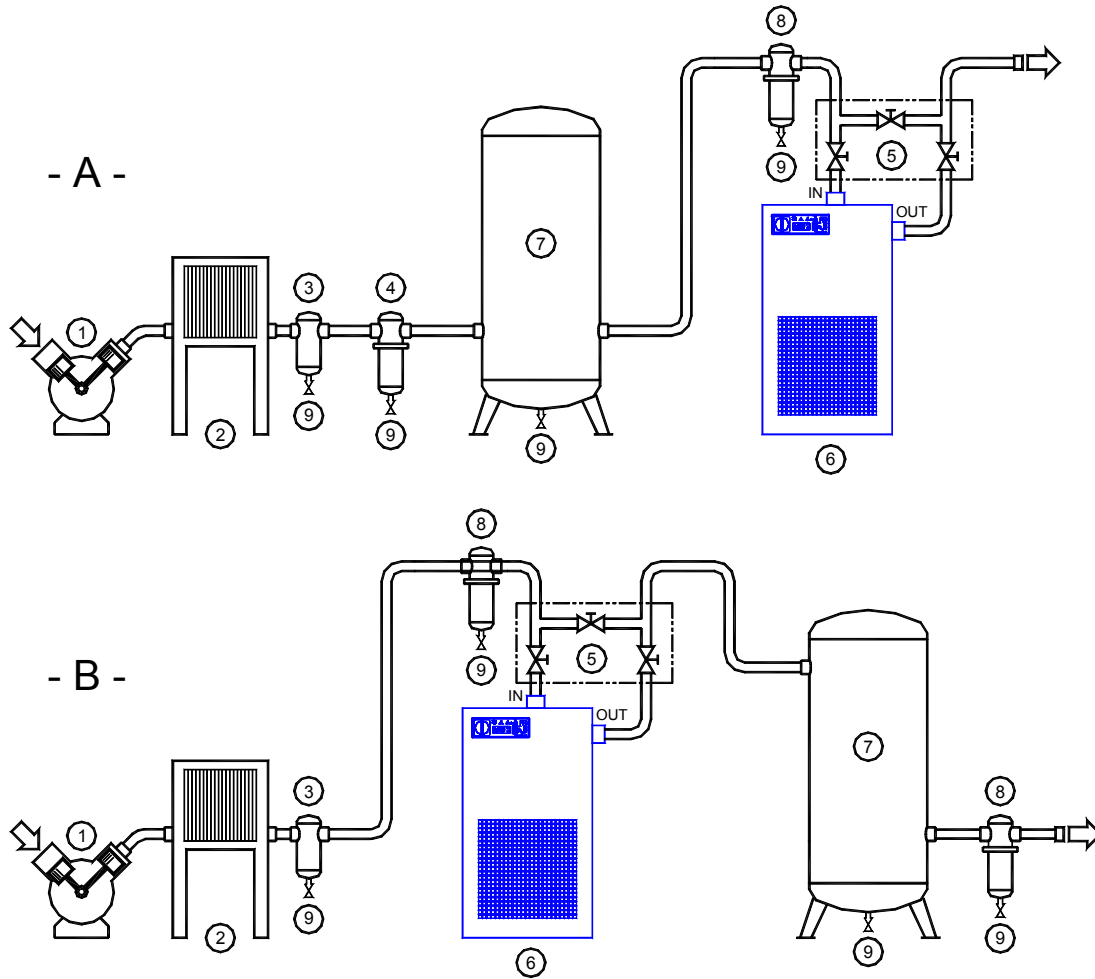

- | | | | |
|---|----------------------|---|---------------------|
| 1 | Air Compressor | 6 | Dryer |
| 2 | Aftercooler | 7 | Compressed Air Tank |
| 3 | Condensate Separator | 8 | Final Filter |
| 4 | Pre-Filter | 9 | Condensate Drain |
| 5 | By-Pass Group | | |

Type A installation is suggested when the compressor operates at reduced intermittence and the total consumption equals the compressor flow rate.

Type B installation is suggested when the air consumption can consistently change with peak values highly exceeding the flow rate of the compressor. The capacity of the tank must be sized in order to compensate eventual instantaneous demand conditions (peak air consumption).

Correction factor for operating pressure changes:									
Inlet air pressure	psig	60	80	100	120	140	160	180	200
Correction Factor		0.80	0.91	1.00	1.08	1.14	1.18	1.21	1.22
Correction factor for ambient temperature changes:									
Ambient temperature	°F	80	90	100	105	110	115		
Correction Factor		1.17	1.12	1.00	0.92	0.83	0.72		
Correction factor for inlet air temperature changes:									
Air temperature	°F	90	100	105	110	120	130		
Correction Factor		1.22	1.00	0.89	0.79	0.63	0.50		
Correction factor for DewPoint changes:									
DewPoint	°F	33-39		40-44		45-49		50-54	
Correction Factor		1.00		1.09		1.22		1.40	

2.4 CONNECTION TO THE COMPRESSED AIR SYSTEM



Operations to be performed by qualified personnel only. Never work on compressed air system under pressure. The user is responsible to ensure that the dryer will never be operated with pressure exceeding the maximum pressure rating on the unit data tag. Over-pressurizing the dryer could be dangerous for both the operator and the unit.

The air temperature and the scfm entering the dryer must comply within the limits stated on the data nameplate. The system connecting piping must be kept free from dust, rust, chips and other impurities, and must be consistent with the flow-rate of the dryer. In order to perform maintenance operations, it is recommended that a dryer by-pass system be installed, as shown in illustration 1.1.

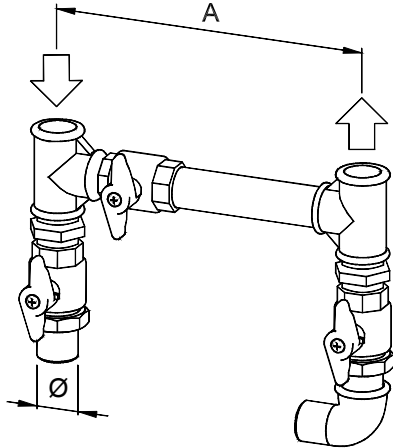

Illustration 1.1

Particular measures have been taken to reduce the amount of vibration that could occur during the operation. Therefore, we recommend the use of connecting pipes that are able to insulate the vibration. (Flexible hoses, vibration damping fittings, etc.)

2.5 ELECTRICAL CONNECTIONS



Qualified personnel should carry out connecting unit to the main power. Be sure to check the local codes in your area.

Before connecting the unit to the electrical supply, verify the data nameplate for the proper electrical information. Voltage tolerance is +/- 5%.

460/3/60 dryers are supplied with a junction box. Be sure to provide the proper fuses or breakers based on the data tag information located on the back of the unit. The main power receptacle must be protected with a thermal overload relay ($I_{\Delta n} + 0.03A$), rated to the power consumption of the dryer (refer to data nameplate for nominal values). The power supply cord must meet or exceed ratings for the total amp draw of the unit.



Connect to a properly grounded outlet. Improper connection of the equipment-grounding conductor can result in risk of electric shock. Do not use adapters on the plug receptacle- if it does not fit the outlet, have a proper outlet installed by a qualified electrician.

2.6 CONDENSATE DRAIN



Discharge is at system pressure. Drain line should be secured. Never point the condensate drain line towards anybody.

The dryer comes with a flexible plastic drain tube (1/4" in diameter and 60 in long) for the connection to suitable drain.

Removal of the condensate occurs through a solenoid valve protected with a mechanical filter. In order to avoid clogging of the solenoid valve, the condensate from the cyclone separator is previously filtered, then discharged. An adjustable electronic timer operates the solenoid valve coil.

The drain cannot be connected to pressurized systems.



Condensate may contain oil. Comply with applicable laws concerning disposal. An oil-water separator should be installed before the air inlet to the dryer for the purpose of removing condensate drainage coming from compressors, dryers, tanks, filters, etc.

3.1 PRELIMINARY OPERATION



Verify that the operating parameters match with the nominal values stated on the data nameplate of the dryer (voltage, frequency, air pressure, air temperature, ambient temperature, etc.).

This dryer has been thoroughly tested, packaged and inspected prior to shipment. Nevertheless, the unit could be damaged during transportation, check the integrity of the dryer during initial start-up and monitor operation during the first hours of operation.



Qualified personnel must perform the initial start-up.

When installing and operating this equipment, comply with all *National Electrical Code* and any applicable federal, state and local codes.

3.2 INITIAL START-UP



This procedure should be followed on initial start-up, after periods of extended shutdown or following maintenance procedures.

Qualified personnel must perform the start-up.

Sequence of operations (refer to paragraph 5.1 Control Panel) :

- Ensure that all the steps of the "Installation" chapter have been observed.
 - Ensure that the connection to the compressed air system is correct and that the piping is suitably fixed and supported.
 - Ensure that the condensate drain pipe is properly fastened and connected to a collection system or container.
 - Ensure that the by-pass system (if installed) is closed and the dryer is isolated.
 - Ensure that the manual valve of the condensate drain circuit is open.
 - Remove any packaging and other material which could obstruct the area around the dryer.
 - Activate the mains switch.
 - Turn on the main switch - pos. 1 on the control panel.
 - Check that the mains detection light of the ON/OFF button - pos. 6 of the control panel - is ON.
 - Switch ON the dryer the button "I - ON" of the ON/OFF switch - pos. 6 of the control panel.
 - Ensure that DMC12 electronic instrument is ON.
 - Ensure the consumption matches with the values of the data plate.
 - **Check that the rotation direction of the fan corresponds with the arrows on the condenser.**
 - Allow the dryer temperature to stabilize at the pre-set value.
 - Slowly open the air inlet valve.
 - Slowly open the air outlet valve.
 - Slowly close the central by-pass valve of the system (if installed).
 - Check the piping for air leakage.
- Ensure the drain is regularly cycling - wait for its first interventions.

3.3 START-UP AND SHUT DOWN



Start-up (refer to paragraph 5.1 Control Panel) :

- Check the condenser for cleanliness.
- Check that the mains detection light of the ON/OFF button - pos. 6 of the control panel - is ON.
- Press the button "I - ON" of the ON/OFF switch - pos. 6 of the control panel.
- Check that the display of electronic instrument DMC12 (Air Dryer Controller) is ON.
- Wait a few minutes, and then check that the DMC12 is indicating a correct DewPoint temperature and the condensate drain is regularly cycling.
- Switch ON the air compressor.



Shut down (refer to paragraph 5.1 Control Panel) :

- Check that the DewPoint temperature indicated on the DMC12 is within range.
- Switch OFF the air compressor.
- After few minutes, switch OFF the dryer pressing the "O - OFF" button of the ON/OFF switch - pos. 6 of the control panel.

NOTE : A DewPoint included in the green operating area of the DMC12 is correct according to the possible working conditions (flow-rate, temperature of the incoming air, ambient temperature, etc.).

During the operation, the refrigeration compressor will run continuously. The dryer must remain ON when ever compressed air is being used, even if the air compressor only loads intermittently.

4.1 TECHNICAL SPECIFICATIONS- ACT600-4 – ACT1000-4 (460/3/60)

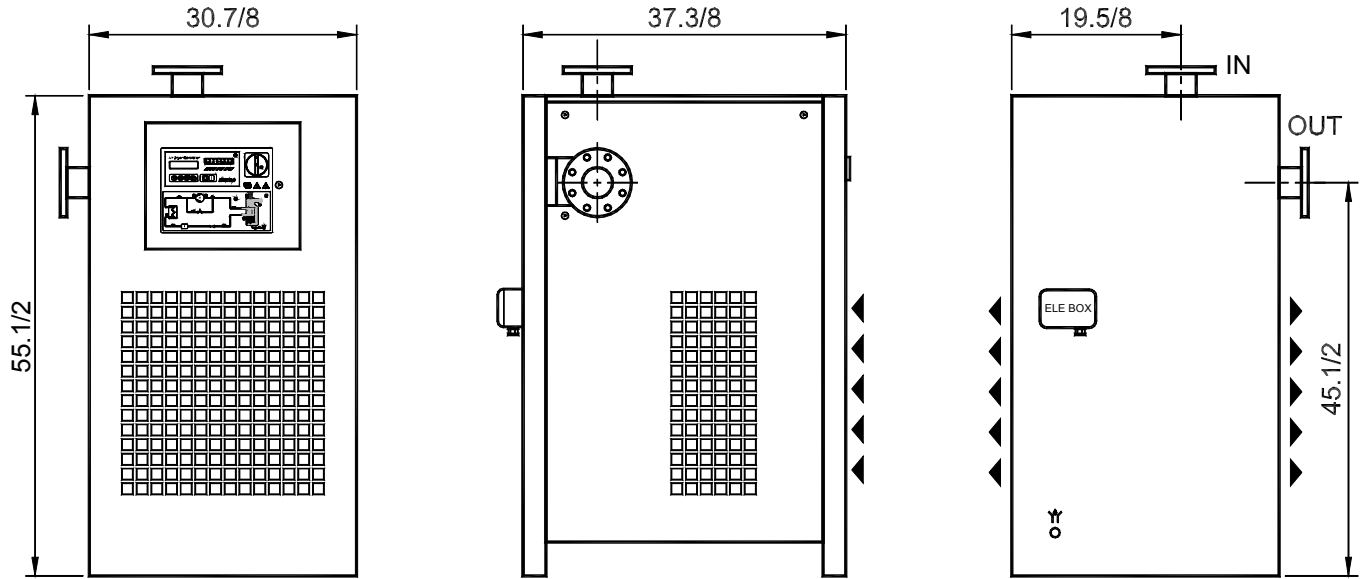

MODEL	ACT600-4	ACT800-4	ACT1000-4
Air flow at nominal condition ¹	600 scfm	800 scfm	1000 scfm
Pressure DewPoint at nominal condition ¹	38 °F		
Nominal (max.) ambient temperature	100 ° F (115 °F)		
Minimum ambient temperature	35 °F		
Nominal (max.) inlet air temperature	100 °F (130 °F)		
Nominal (max.) inlet air pressure	100psig (200psig)		
Maximum outlet air pressure drop-ΔP	2.2 psi	3.4 psi	2.7 psi
Inlet-Outlet air connection	ASA 3" #150		
Refrigerant - Type	R404A	R404A	R404A
Charge	65 oz	95 oz	106 oz
Cooling air fan flow	3240 cfm	3650 cfm	3890 cfm
Heat Load	27600 Btu/h	45200 Btu/h	56300 Btu/h
Voltage	460/3/60		
Nominal refrigeration compressor power	1.3/4 HP	3 HP	3.3/4 HP
Nominal electrical consumption	3200W 4.8A	5000W 7.7A	5800W 9.0A
Maximum electrical consumption	3700W 5.5A	5800W 8.7A	6700W 10.0A
Maximum noise level	< 70dba at 40 in		
Weight net	405 lbs	420 lbs	600 lbs
gross	570 lbs	585 lbs	765 lbs

¹ The nominal condition refers to ambient temperature of 100°F with inlet air 100 psig and 100°F

Correction factor for operating pressure changes:									
Inlet air pressure	psig	60	80	100	120	140	160	180	200
Correction Factor		0.80	0.91	1.00	1.08	1.14	1.18	1.21	1.22
Correction factor for ambient temperature changes:									
Ambient temperature	°F	80	90	100	105	110	115		
Correction Factor		1.17	1.12	1.00	0.92	0.83	0.72		
Correction factor for inlet air temperature changes:									
Air temperature	°F	90	100	105	110	120	130		
Correction Factor		1.22	1.00	0.89	0.79	0.63	0.50		
Correction factor for DewPoint changes:									
DewPoint	°F	33-39	40-44	45-49	50-54				
Correction Factor		1.00	1.09	1.22	1.40				

4.2 TECHNICAL SPECIFICATIONS- ACT1500-4 – ACT2000-4 (460/3/60)

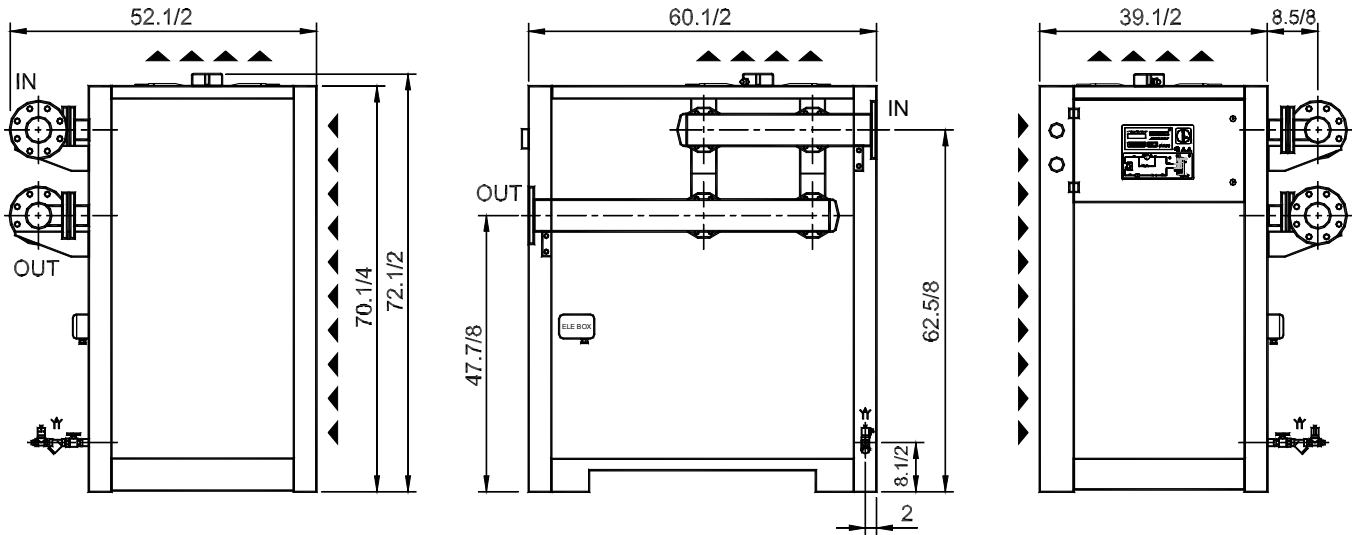

MODEL	ACT1500-4	ACT1750-4	ACT2000-4
Air flow at nominal condition ¹	1500 scfm	1750 scfm	2000 scfm
Pressure DewPoint at nominal condition ¹	38 °F		
Nominal (max.) ambient temperature	100 ° F (115 °F)		
Minimum ambient temperature	35 °F		
Nominal (max.) inlet air temperature	100 °F (130 °F)		
Nominal (max.) inlet air pressure	100psig (200psig)		
Maximum outlet air pressure drop-ΔP	3.2 psi	2.2 psi	2.7 psi
Inlet-Outlet air connection	ASA 4" #150		
Refrigerant - Type	R404A	R404A	R404A
Charge	320 oz	342 oz	353 oz
Cooling air fan flow	3240 cfm	3650 cfm	3890 cfm
Heat Load	91700 Btu/h	91700 Btu/h	104000 Btu/h
Voltage	460/3/60		
Nominal refrigeration compressor power	6 HP	6 HP	6.3/4 HP
Nominal electrical consumption	10000W 14.5A	10500W 15.0A	11600W 16.7A
Maximum electrical consumption	11500W 16.2A	12000W 17.0A	13500W 19.1A
Maximum noise level	< 70dba at 40 in		
Weight net	1200 lbs	1300 lbs	1350 lbs
gross	1490 lbs	1590 lbs	1640 lbs

¹ The nominal condition refers to ambient temperature of 100°F with inlet air 100 psig and 100°F

Correction factor for operating pressure changes:

Inlet air pressure	psig	60	80	100	120	140	160	180	200
Correction Factor		0.80	0.91	1.00	1.08	1.14	1.18	1.21	1.22

Correction factor for ambient temperature changes:

Ambient temperature	°F	80	90	100	105	110	115
Correction Factor		1.17	1.12	1.00	0.92	0.83	0.72

Correction factor for inlet air temperature changes:

Air temperature	°F	90	100	105	110	120	130
Correction Factor		1.22	1.00	0.89	0.79	0.63	0.50

Correction factor for DewPoint changes:

DewPoint	°F	33-39	40-44	45-49	50-54
Correction Factor		1.00	1.09	1.22	1.40

5.1 CONTROL PANEL

The control panel depicted below is the only operator interface

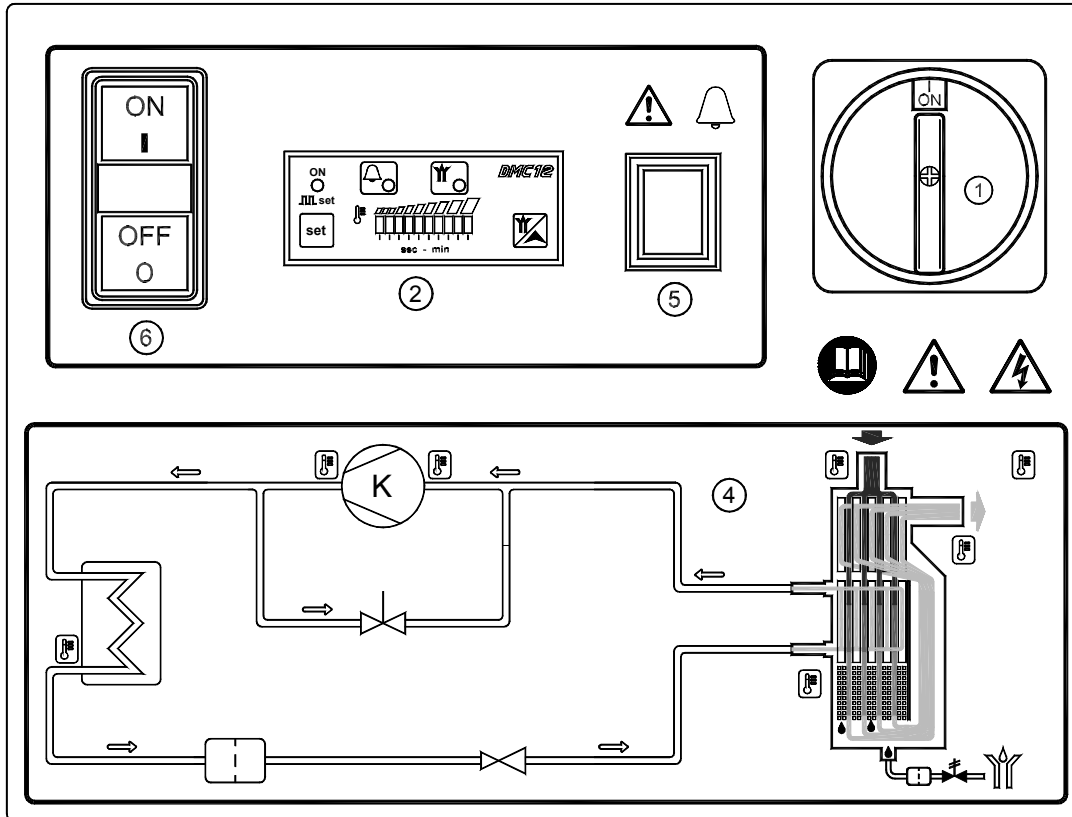

- | | | | |
|---|----------------------------|---|--|
| 1 | Rotary Switch | 4 | Air and refrigeration gas flow diagram |
| 2 | DMC12 Air Dryer Controller | 5 | Alarm light |
| 3 | - | 6 | ON/OFF switch with mains detecting light |

5.2 OPERATION

Operating principal - The dryer models described in this manual operate all on the same principal. The hot moisture laden air enters an air to air heat exchanger. The air then goes through the evaporator, also known as the air to refrigerant heat exchanger. The temperature of the air is reduced to approximately 35-39 degrees Fahrenheit, causing water vapor to condense to liquid. The liquid is continuously coalesced and collected in the separator for removal by the condensate drain. The cool moisture free air then passes back through the air to air heat exchanger to be reheated to within fifteen degrees of the incoming air temperature as it exits the dryer.

Refrigerant circuit - Refrigerant (R404a) gas is cycled through the compressor and exits at high pressure to an air condenser where heat is removed causing the refrigerant to condense to a high-pressure liquid state. The liquid is forced through a metering device (capillary tube or thermal expansion valve) where the resulting pressure drop allows the refrigerant to boil off at a predetermined temperature. Low-pressure liquid refrigerant enters the heat exchanger where heat from the incoming air is transferred causing the refrigerant to boil; the resulting phase change produces a low pressure, low temperature gas. The low-pressure gas is returned to the compressor, where it is re-compressed and begins the cycle again. During those periods when the compressed air load is reduced the excess refrigerant is by-passed automatically back to the compressor via the hot gas by-pass valve circuit.

5.3 AIR/REFRIGERANT FLOW DIAGRAM

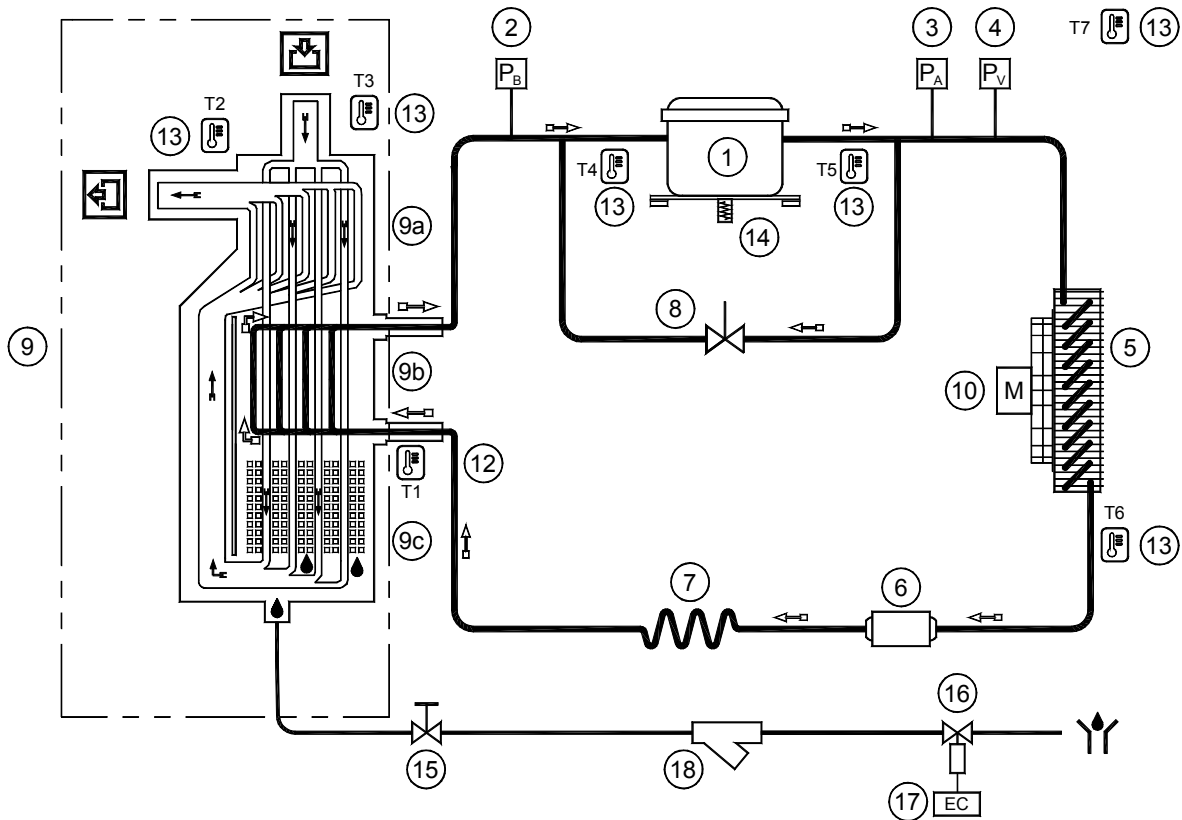

- | | | | |
|----|--|----|--|
| 1 | Refrigeration Compressor | 10 | Condenser fan assembly |
| 2 | Refrigerant Pressure Switch P_B (Low Pressure) | 11 | - |
| 3 | Refrigerant Pressure Switch P_A (High Pressure) | 12 | T1 DewPoint temperature probe |
| 4 | Refrigerant Fan Pressure Switch P_V
$P_{V1} - P_{V2}$ (ACT 1500-4 – ACT 2000-4) | 13 | T2-T8 Temperature probes (if installed) |
| 5 | Air Condenser | 14 | Compressor crankcase heater (if installed) |
| 6 | Filter Drier | 15 | Condensate drain isolation valve |
| 7 | Capillary Tube | 16 | Condensate drain solenoid valve |
| 8 | Constant Pressure By-pass Valve | 17 | EC = Air Dryer Controller |
| 9 | ACT Heat Exchanger Module | 18 | Condensate drain strainer |
| 9a | Air to air heat exchanger | | |
| 9b | Air-to-refrigerant exchanger | | |
| 9c | Condensate separator | | |

⇒ Air flow direction

⇒ Refrigerating gas flow direction

5.4 REFRIGERATION COMPRESSOR

The refrigeration compressor is the pump in the system, gas coming from the evaporator (low pressure side) is compressed up to the condensation pressure (high pressure side). The compressors utilized are manufactured by leading manufacturers and are designed for applications where high compression ratios and wide temperature changes are present. The hermetically sealed construction is perfectly gas tight, ensuring high-energy efficiency and long, useful life. Dumping springs support the pumping unit in order to reduce the acoustic emission and the vibration diffusion. The aspirated refrigeration gas, flowing through the coils before reaching the compression cylinders cools the electric motor. The thermal protection protects the compressor from over heating and over currents. The protection is automatically restored as soon as the nominal temperature conditions are reached.

5.5 CONDENSER UNIT

The condenser is the component in which the gas coming from the compressor is cooled down and condensed becoming a liquid. Mechanically, a serpentine copper tubing circuit (with the gas flowing inside) is encapsulated in an aluminum fin package. The cooling operation occurs via a high efficiency fan, creating airflow within the dryer, moving air through the fin package. It's mandatory that the ambient air temperature does not exceed the nominal values. It is also important **TO KEEP THE CONDENSER UNIT FREE FROM DUST AND OTHER IMPURITIES.**

5.6 FILTER DRIER

Traces of humidity and slag can accumulate inside the refrigeration circuit. Long periods of use can also produce sludge. This can limit the lubrication efficiency of the compressor and clog the expansion valve or capillary tube. The function of the filter drier, located before the capillary tubing, is to eliminate any impurities from circulating through the system.

5.7 CAPILLARY TUBE

It consists of a piece of reduced cross section copper tubing located between the condenser and the evaporator, acting as a metering device to reduce the pressure of the refrigerant. Reduction of pressure is a design function to achieve optimum temperature reached within the evaporator: the smaller the capillary tube outlet pressure, the lower the evaporation temperature.

The length and interior diameter of the capillary tubing is accurately sized to establish the performance of the dryer; no maintenance or adjustment is necessary.

5.8 ACT HEAT EXCHANGER MODULE

The heat exchanger module houses the air-to-air, the air-to-refrigerant heat exchangers and the demister type condensate separator. The counter flow of compressed air in the air-to-air heat exchanger ensures maximum heat transfer. The generous cross section of flow channel within the heat exchanger module leads to low velocities and reduced power requirements. The generous dimensions of the air-to-refrigerant heat exchanger plus the counter flow gas flow allows full and complete evaporation of the refrigerant (preventing liquid return to the compressor). The high efficiency condensate separator is located within the heat exchanger module. No maintenance is required and the coalescing effect results in a high degree of moisture separation.

5.9 HOT GAS BY-PASS VALVE

This valve injects a portion of the hot gas taken from the discharge side of the compressor. As needed, hot gas is injected into the return side between the evaporator and the suction port of the compressor, keeping the evaporation temperature/pressure constant at approx. 36°F. This injection prevents the formation of ice build-up inside the dryer evaporator at every load condition.



ADJUSTMENT

The hot gas by-pass valve is adjusted during the manufacturing/testing phase. As a rule no adjustment is required; If it is necessary, a qualified refrigeration technician must carry out the operation.

ACT 500 to ACT1000

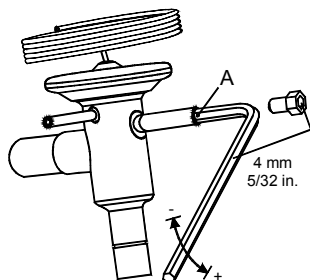

ACT 1500 to ACT2000

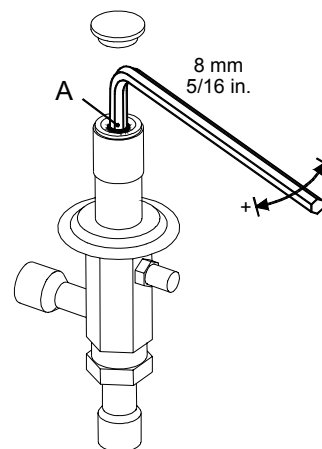

5.10 REFRIGERANT PRESSURE SWITCH PA - PB - PV

To provide operational protection, pressure switches are installed in the refrigeration circuit. Refer to exploded view diagrams for application of pressure switches on individual models.

- PB :** Low-pressure sensing device on the discharge (high-pressure) side of the compressor is activated when the pressure drops below the pre-set value. Electrical continuity is interrupted and the unit is disabled until nominal conditions are restored.
Calibrated pressure : R 404 A Activate 15 psig – Unit Restart 73 psig
- PA :** High-pressure sensing device on the discharge (high-pressure) side of the compressor is activated when the pressure exceeds the pre-set value. Electrical continuity is interrupted and the unit is disabled. Depressing a manual-reset button mounted on the controller itself restores operation.
Calibrated pressure : R 404 A Activate 440 psig - Manual reset
- PV :** Fan pressure switch is located on the discharge side of the compressor. At upper limit, continuity is restored to the condenser fan. At lower limit continuity is interrupted. Condenser temperature/pressure remains constant within preset limits
Calibrated pressure : R 404 A Upper Limit 290 psig (113°F) – Lower Limit 261 psig (104°F) - Tolerance ± 15 psi

ACT 1500-4 – ACT2000-4

- PV1 :** Fan control pressure switch is placed at the discharge side of refrigeration compressor. It keeps the condensation temperature/pressure constant within preset limits – Low Speed.
Calibrated pressure : R 404 A Upper Limit 261 psig (106°F) – Lower Limit 304 psig (117°F) - Tolerance ± 15 psi
- PV2 :** Fan control pressure switch is placed at the discharge side of refrigeration compressor. It keeps the condensation temperature/pressure constant within preset limits – High Speed.
Calibrated pressure : R 404 A Upper Limit 297 psig (115°F) – Lower Limit 334 psig (124°F) - Tolerance ± 15 psi





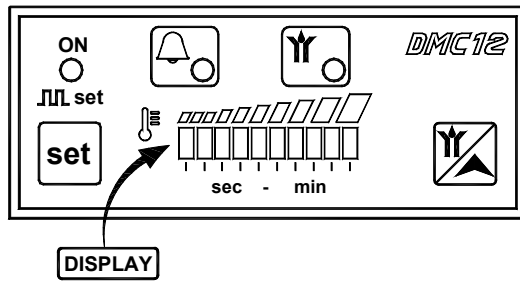

5.11 COMPRESSOR CRANKCASE HEATER

At low temperatures, when the compressor starts, oil can be drawn into the refrigeration circuit and liquid hammering could occur. To prevent this, an electrical resistance heater is installed in the suction side of the compressor. When the system is powered and the compressor is not running, this heater keeps the oil at the correct temperature. This heater is controlled by a thermostat which prevents overheating the oil.

NOTE : The heater must be powered at least a couple of hours before the start up of the refrigeration compressor.

5.12 DMC12 ELECTRONIC INSTRUMENT (AIR DRYER CONTROLLER)





-  Button - access the set-up.
-  Button - condensate drain test / value increment.
-  LED - glowing = power on.
-  LED - flashing = set-up condition.
-  LED - access the set-up.
-  LED - DewPoint too high alarm.

The DMC12 controller performs a double function : it shows the current operating DewPoint through the digital led display and it controls the functioning of condensate drain solenoid valve through the cyclic electronic timer. The alarm LED of the electronic instrument shows any "DewPoint too high" alarm condition. DMC12 allows also remote annunciation of this alarm condition of the dryer :

- with dryer off or in alarm conditions there is no voltage from terminal 1 and 4 of electronic instrument (please also see electric drawings into the attachments);
- whereas, with dryer on and correct operating DewPoint, there is voltage from terminal 1 and 4 of electronic instrument (please also see electric drawings into the attachments).

OPERATION - During the dryer operation, the LED  is on. The 10 LED display indicates the current operating DewPoint, shown by means of a three colors (blue-green-red) bar over the display itself.

- Blue section - the dryer is working with very low load conditions, the DewPoint of the dryer is quite low;
- Green section - operating conditions ensuring an optimal DewPoint;
- Red section - DewPoint of the dryer too high, the treatment of the compressed air may be improper.





The condensate drain solenoid valve is activated for 2 seconds (T_{ON}) -  LED on - each minute (T_{OFF}), if standard setting. To perform the manual test for the condensate drain, press the  button.







The "out of scale" conditions are indicated by the intermittent flashing of the first and the last LED of the display, respectively showing the exceeding of the lower or the upper range.

SET-UP - The DMC12 is adjusted during the final test of the dryer. In case of particular requirements concerning the operation management, the user can change the setting of the programmed parameters.

The parameters which can be set up are the following :

- Set-point - activation temperature of "DewPoint too high" alarm condition.
- T_{ON} - activation time of the condensate drain solenoid valve.
- T_{OFF} - pause time between two consecutive activation of the condensate drain solenoid valve.

To access the set-up, keep pressed the  button for at least 2 seconds;  LED flashing confirms the command. First appears the Set-Point parameter; to access the other parameters, press sequentially the  button. To change the value of the selected parameter, keep pressed the  button and operate on button ; the current value is shown on the LED display. For the value range and the resolution (value of each single LED), see the following table :

Parameter	Description	Display	Value range	Resolution	Set value
Set-point	Activation temperature of "DewPoint too high" alarm	Synchronous flashing LED  + LED 	0 - 13,5 °C	1,5 °C	13,5 °C
T_{ON}	Activation time of the condensate drain solenoid valve	Synchronous flashing LED  + LED 	1 - 10 sec	1 sec	2 sec
T_{OFF}	Pause time of the condensate drain solenoid valve	Non-synchronous flashing LED  + LED 	1 - 10 min	1 min	1 min

To exit the set-up condition in any moment, press the  button. In case no operations are made during 2 minutes, the system exits automatically the set-up condition.

5.13 ELECTRICAL SCHEMATIC ACT600-4 – ACT1000-4 (460/3/60) Page 1 of 3

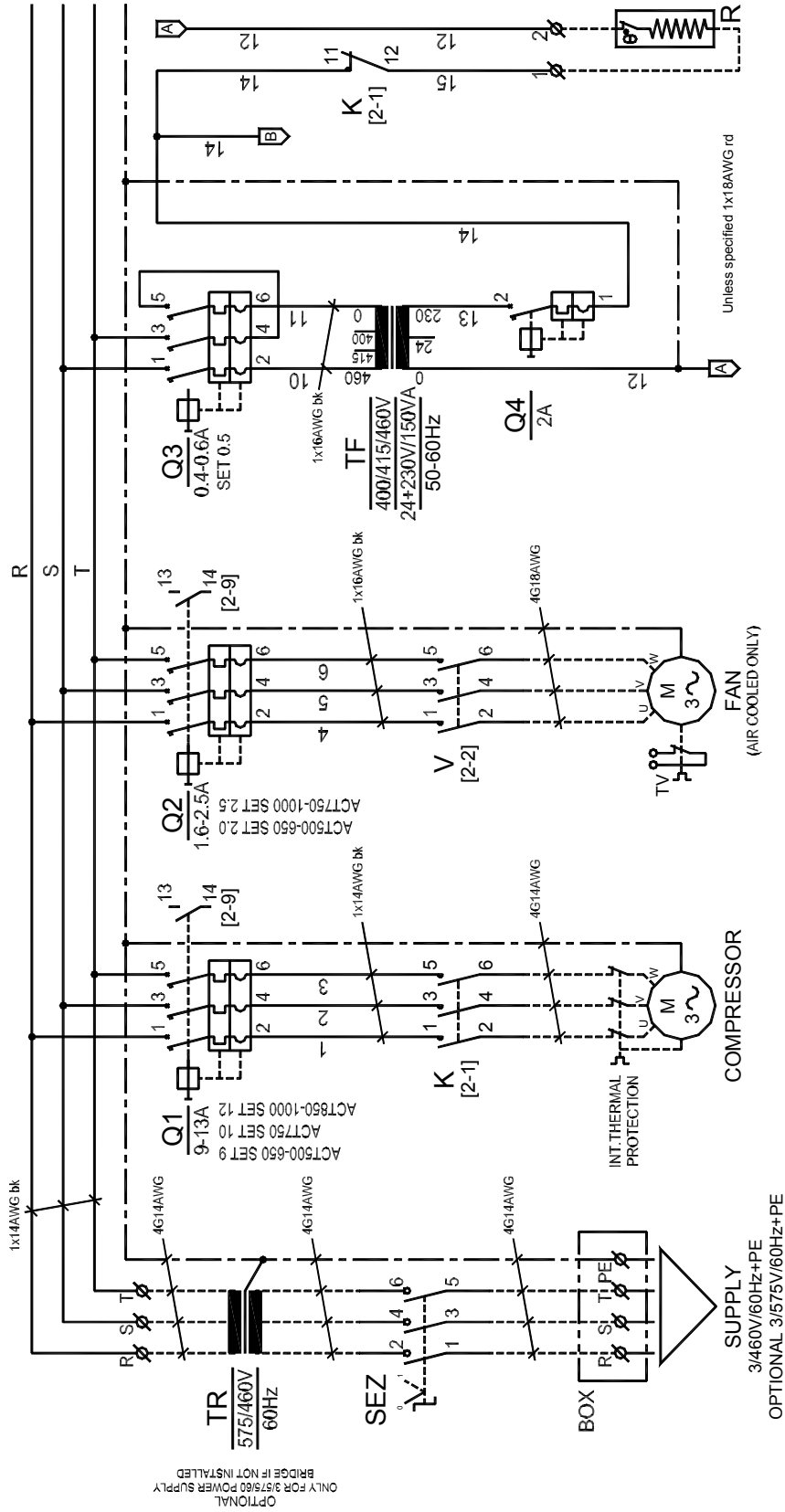

LEGEND

- SEZ : MAIN SWITCH WITH DOOR BLOCK
- DMC12 : DMC-12 AIR DRYER CONTROLLER
- P : START-STOP BUTTON - POWER ON LIGHT
- X : ALARM ON LIGHT
- EVD : CONDENSATE DRAIN SOLENOID VALVE
- R : COMPRESSOR CRANKCASE HEATER
- BOX : ELECTRIC SUPPLY BOX
- PB : PRESSURE SWITCH - COMPRESSOR SUCTION (LOW) SIDE
- PA : PRESSURE SWITCH - COMPRESSOR DISCHARGE (HIGH) SIDE
- PV : PRESSURE SWITCH - FAN CONTROL
- TV : THERMAL PROTECTION INSIDE FAN
- CP : CONTROL PANEL

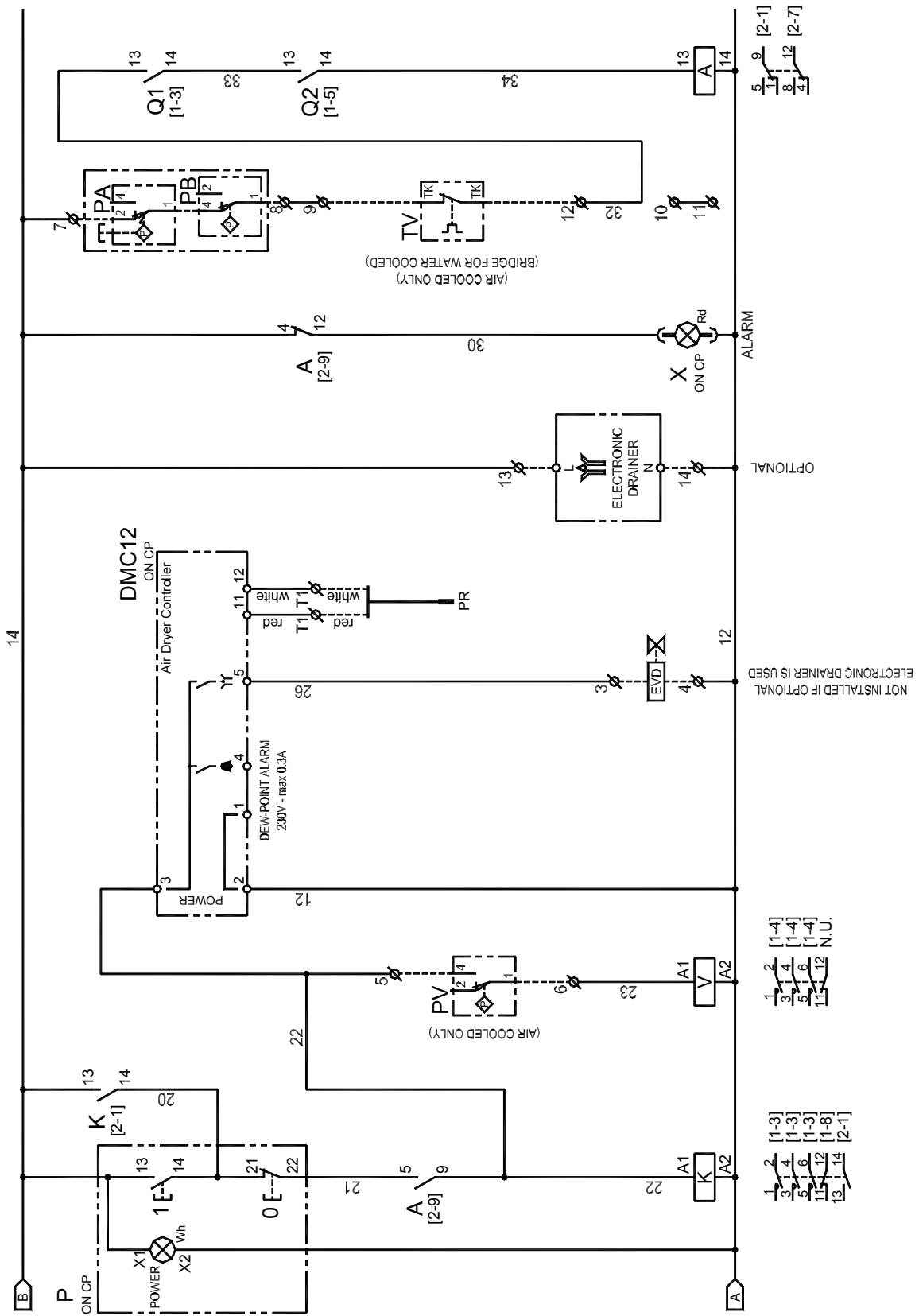

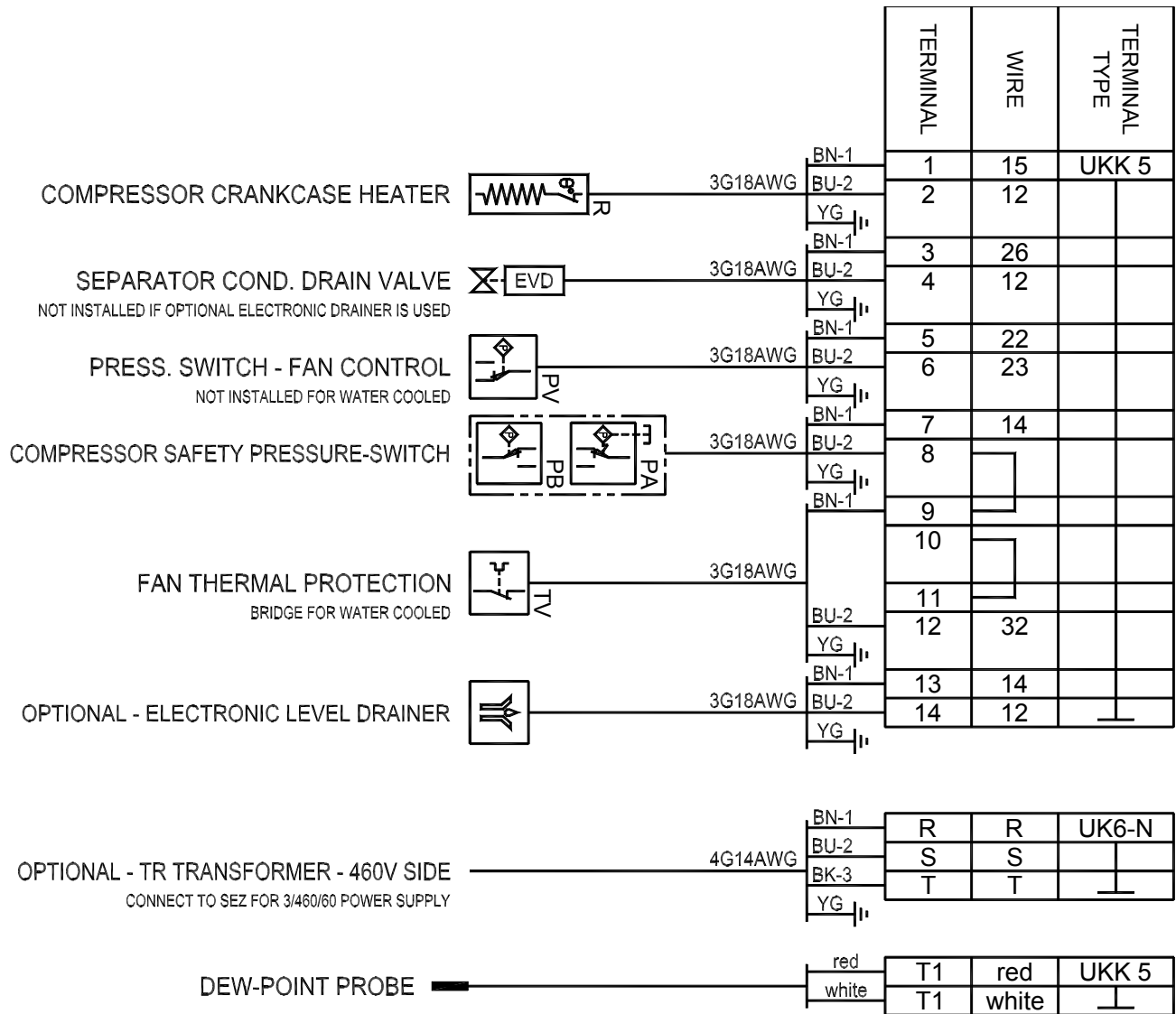

BN=BROWN
 BU=BLUE
 BK=BLACK
 YG=YELLOW/GREEN

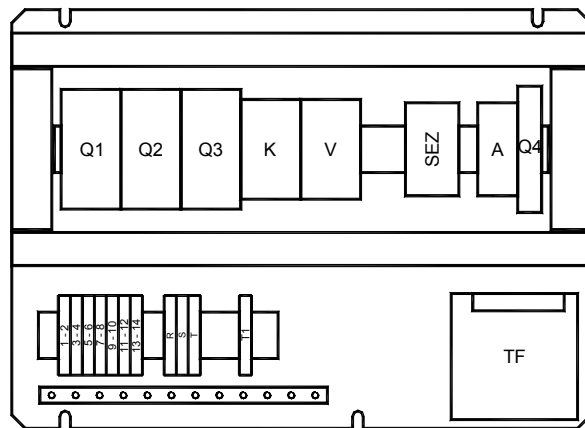

MOUNTING PLATE

5.14 ELECTRICAL SCHEMATIC ACT1500-4 – ACT2000-4 (460/3/60) Page 1 of 3

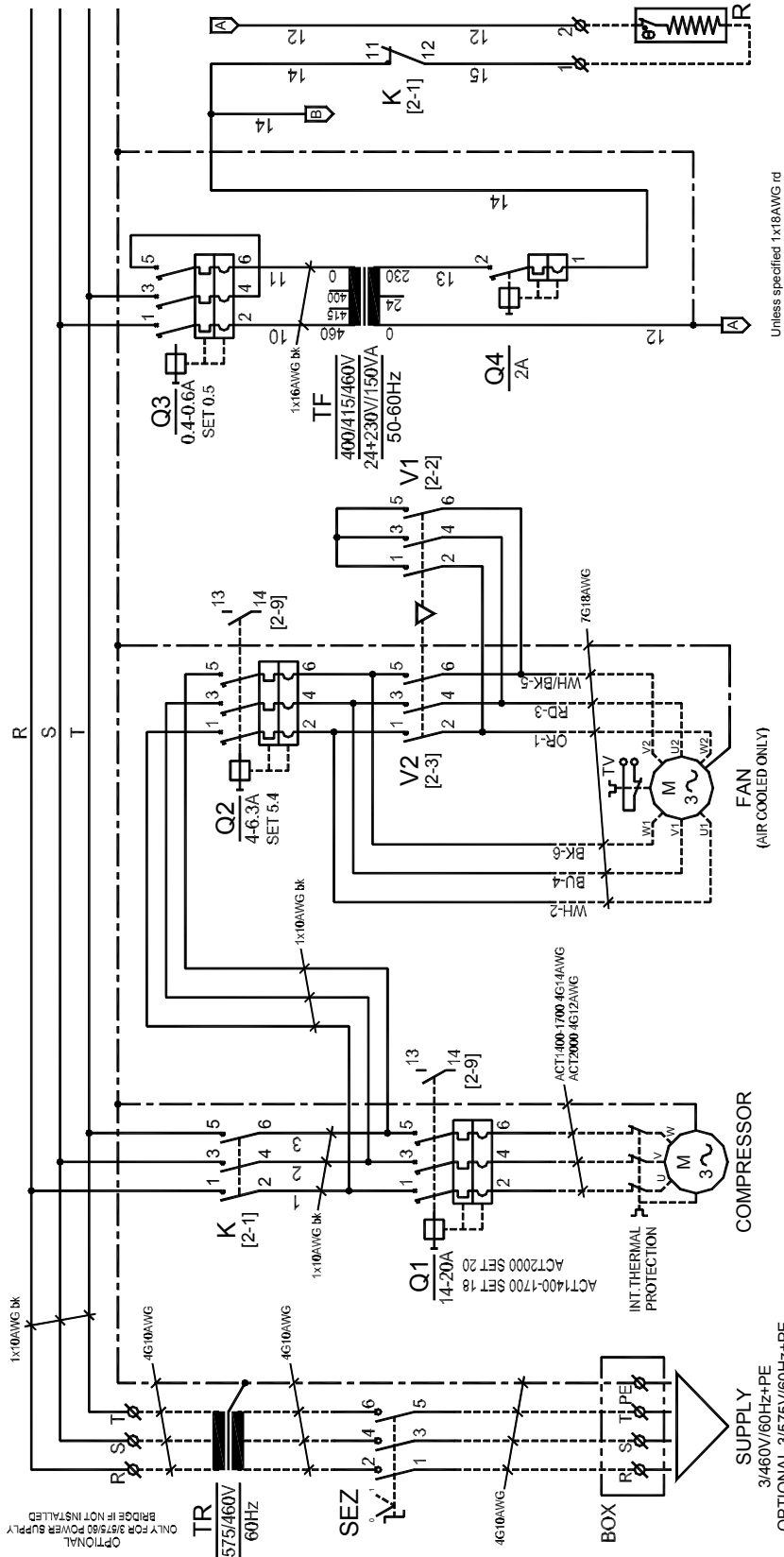

- LEGEND**
- SEZ : MAIN SWITCH WITH DOOR BLOCK
 - DMC12 : DMC12 AIR DRYER CONTROLLER
 - P : START-STOP BUTTON - POWER ON LIGHT
 - X : ALARM ON LIGHT
 - EVD : CONDENSATE DRAIN SOLENOID VALVE
 - R : COMPRESSOR CRANKCASE HEATER
 - BOX : ELECTRIC SUPPLY BOX
 - PB : PRESSURE SWITCH - COMPRESSOR SUCTION (LOW) SIDE
 - PA : PRESSURE SWITCH - COMPRESSOR DISCHARGE (HIGH) SIDE
 - PV1 : PRESSURE SWITCH - FAN CONTROL - LOW SPEED
 - PV2 : PRESSURE SWITCH - FAN CONTROL - HIGH SPEED
 - TV : THERMAL PROTECTION INSIDE FAN
 - SD : FAN DOOR INTERLOCK SAFETY-SWITCH
 - CP : CONTROL PANEL

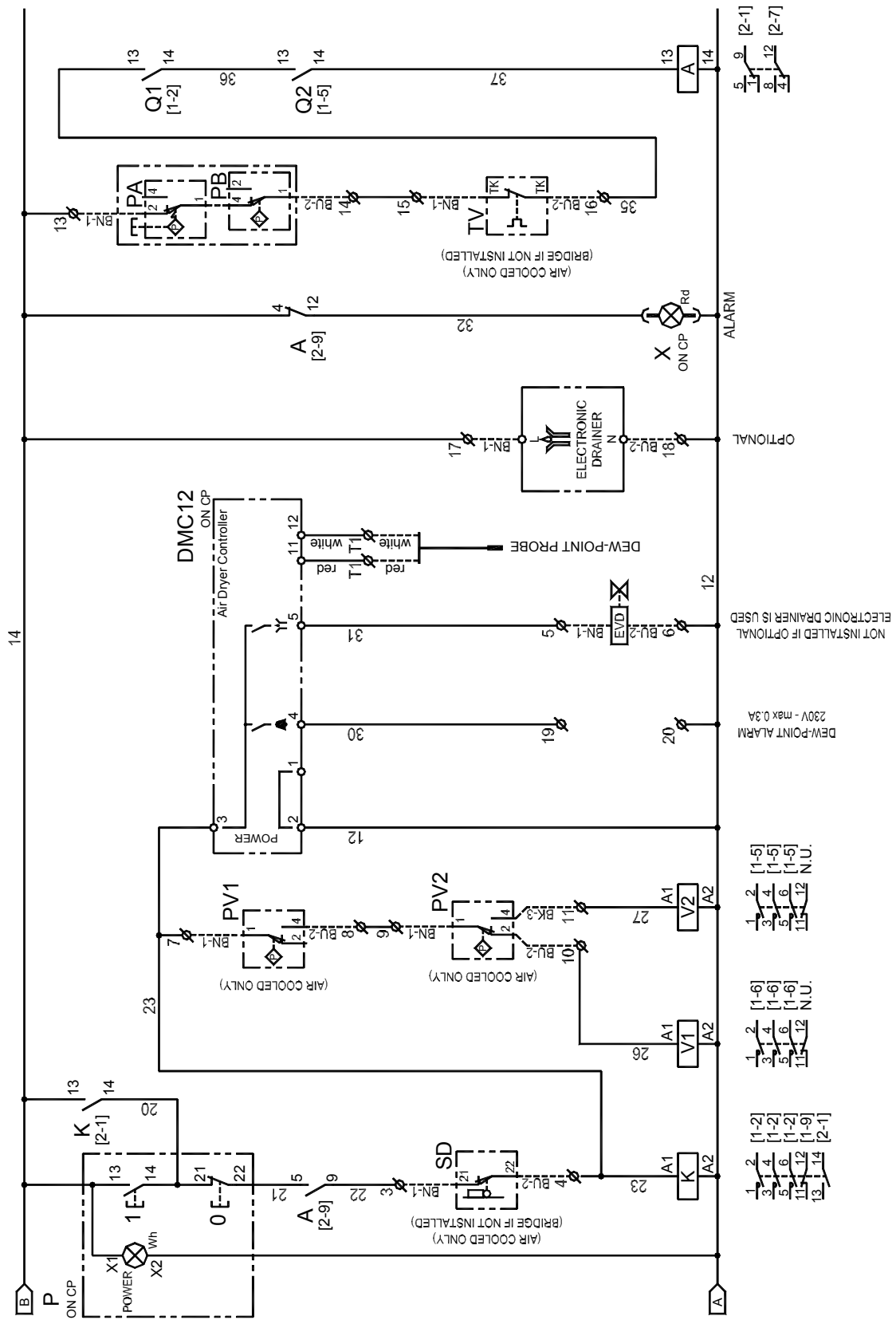

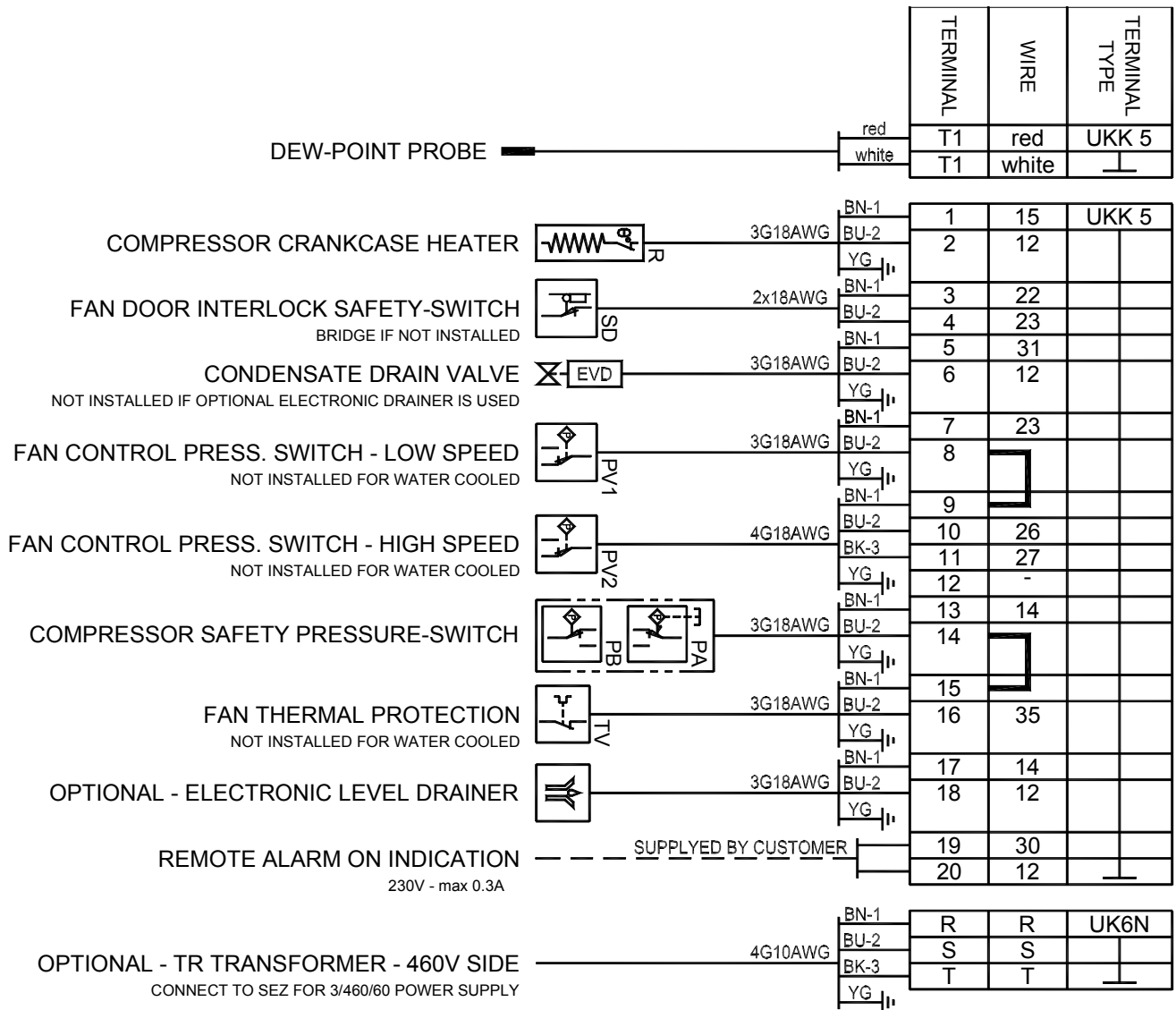

OR=ORANGE
RD=RED
WH=WHITE
WH/BK=WHITE/BLACK
BN=BROWN
BU=BLUE
BK=BLACK
YG=YELLOW/GREEN

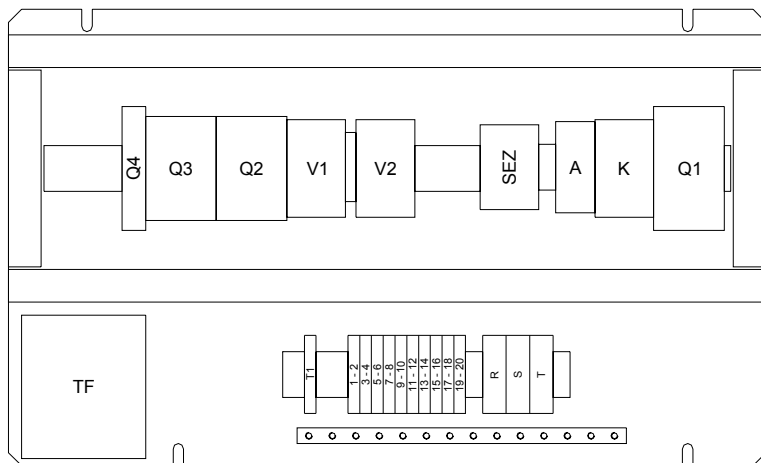

MOUNTING PLATE

6.1 MAINTENANCE SCHEDULE



Only qualified personnel should perform maintenance operations.

Prior to performing any maintenance or service, be sure that:

- Ensure that the power is off and the unit is at atmospheric pressure.
- Main power circuit breaker is in the off position per lock out/tag out procedures.
- Ensure that maintenance personnel have read and understand the safety and operation instructions in this manual.



High temperature conditions exist during operation of system. Avoid contact until system or component has dissipated heat.



DAILY

- Verify that the DewPoint displayed on the electronic instrument is within normal operating parameters.
- Check the proper operation of the condensate drain system.
- Inspect the condenser for cleanliness.



EVERY 200 HOURS OR MONTHLY

- Blow entire unit out with compressed air (Max. 30 psig)
- Blow air condenser coils out with compressed air.
- Close the isolation valve for the condensate drain, remove the mechanical filter and clean it with compressed air and a brush. Reinstall the filter, make sure it is secure, and open the isolation valve.
- Verify operation of the machine.



EVERY 1000 HOURS OR YEARLY

- Tighten all electrical connections. Inspect unit for broken, cracked or bare wires.
- Inspect refrigeration circuit for signs of oil and refrigerant leakage.
- Measure and record amperage. Verify that readings are within acceptable parameters as listed in specification table.
- Inspect condensate drain flexible hoses, and replace if necessary.
- Verify operation of the machine.

6.2 REPLACEMENT PARTS

◆ *Suggested spare part*

DESCRIPTION	Part Number	ACT (460/3/60)		
		600-4	800-4	1000-4
Heat Exchange Module-ACT	5870600014	1		
Heat Exchange Module-ACT	5870800014		1	
Heat Exchange Module-ACT	5871000014			1
Fan Motor Assembly (Motor/Fan Blade/Guard)	5250355090	1		
Fan Motor Assembly (Motor/Fan Blade/Guard)	5250355100		1	1
Rotary Power Switch	5450SZN100	1	1	1
DMC12 Controller	5620110101	1	1	1
DewPoint Probe-DMC12	5625NNN037	1	1	1
Condensate Y-Strainer	64355FF011	1	1	1
Drain Solenoid Valve Body	64320FF020	1	1	1
Drain Solenoid Valve Coil	64N22MM021	1	1	1
Hot Gas By-pass Valve	64140SS155	1	1	1
Filter Drier	6650SSN165	1	1	1
Fan Pressure Switch	5655NNN093	1	1	1
Double Pressure Switch	5655NNN095	1	1	1
Air Condenser	5810138006	1		
Air Condenser	5810210006		1	
Air Condenser	5810300010			1
Q1 – Circuit breaker	54443SM152	1	1	1
Q2 – Circuit breaker	54443SM135	1	1	1
Q3 – Circuit breaker	54443ST020	1	1	1
Q4 – Circuit breaker	54441C6005	1	1	1
Q1-Q2 – Auxiliary contact	5490CAX060	2	2	2
K – Power contact	5454TLT116	1	1	1
K – Auxiliary contact	5490CAX011	1	1	1
V – Power contact	5454TLT111	1	1	1
A – Auxiliary relay coil	5456REL110	1	1	1
A – Relay socket	5456REL015	1	1	1
P – Double ON/OFF button with light	5452PLS020	1	1	1
P – Neon lamp for double button	5480NEN010	1	1	1
X – Rectangular red indicator 18x24	5452IND005	1	1	1
X – Neon lamp for red indicator	5458NEN005	1	1	1
TF – Transformer	5440TFM025	1	1	1

REPLACEMENT PARTS

◆ *Suggested spare part*

DESCRIPTION	Part Number	ACT (460/3/60)		
		600-4	800-4	1000-4
Compressor	5015340002	1		
Compressor	5015340003		1	
Compressor	5015340007			1
Front Panel	680AC250ANTC2	1	1	
Front Panel	680AC300ANTC2			1
Top Panel	680AC250CPRC2	1	1	1
Side Panel 1	680AC250LT1R	1	1	1
Side Panel 2	680AC250LT2R	1	1	1
Side Support 1	680AC250S21X	2	2	2
Side Support 2	680AC250S25X	2	2	2
Side Support 3	680AC250S27X	1	1	1
Side Panel Support	680AC250S31X	2	2	
Side Panel Support	680AC250S35X			2
Rear Panel	680AC250PSTC2	1	1	1
Pressure Control Mounting Bracket	680PL160S01X	1	1	1
Exterior Panel Mounting Support	680AC250S20X	4	4	4
Compressor Support	680AC250S22X	1	1	1
Heat Exchanger Support	680AC250S23X	2	2	2
Condenser Support	680AC250S24X	1	1	
Condenser Support	680AC250S34X			1
QE Box	680PL250MNAC2	1	1	1
QE Box door for DMC12	680PL250PTRC2	1	1	1

REPLACEMENT PARTS

◆ *Suggested spare part*

DESCRIPTION	Part Number	ACT (460/3/60)		
		1500-4	1750-4	2000-4
Heat Exchange Module-ACT	5871500014	2		
Heat Exchange Module-ACT	5871750014		2	
Heat Exchange Module-ACT	5872000014			2
Fan Motor Assembly (Motor/Fan Blade/Guard)	5250355105	1	1	1
Rotary Power Switch	5450SZN105	1	1	1
DMC12 Controller	5620110101	1	1	1
DewPoint Probe-DMC12	5625NNN037	1	1	1
Condensate Y-Strainer	64355FF006	1	1	1
Drain Solenoid Valve Body	64320FF020	1	1	1
Drain Solenoid Valve Coil	64N22MM021	1	1	1
Hot Gas By-pass Valve	64140SS102	1	1	
Hot Gas By-pass Valve	64140SS105			1
Filter Drier	6650SSN175	1	1	1
Fan Pressure Switch	5655NNN093	1	1	1
Double Pressure Switch	5655NNN095	1	1	1
Air Condenser	5810400004	1		
Air Condenser	5810500004		1	1
Condenser Filter	2250FLC050	1	1	1
LP Manometer	5660NNN005	1	1	1
HP Manometer	5660NNN005	1	1	1
Q1 – Circuit breaker	54443SM160	1	1	1
Q2 – Circuit breaker	54443SM145	1	1	1
Q3 – Circuit breaker	54443ST020	1	1	1
Q4 – Circuit breaker	54441C6005	1	1	1
Q1-Q2 – Auxiliary contact	5490CAX060	2	2	2
K – Power contact	5454TLT125	1	1	1
V1-V2 – Power contact	5454TLT111	2	2	2
K – Auxiliary contact	5490CAX010	1	1	1
K – Auxiliary contact	5490CAX011	1	1	1
V1-V2 Mechanical interlock for power contactors	5490INM010	1	1	1
A – Auxiliary relay coil	5456REL110	1	1	1
A – Relay socket	5456REL015	1	1	1
P – Double ON/OFF button with light	5452PLS020	1	1	1
P – Neon lamp for double button	5480NEN010	1	1	1
X – Rectangular red indicator 18x24	5452IND005	1	1	1
X – Neon lamp for red indicator	5458NEN005	1	1	1
TF – Transformer	5440TFM025	1	1	1

REPLACEMENT PARTS

◆ *Suggested spare part*

DESCRIPTION	Part Number	ACT (460/3/60)		
		1500-4	1750-4	2000-4
Compressor	5015340018	1	1	
Compressor	5015340021			1
Front Panel	680AC400ANTC2	1	1	1
Top Panel	680AC400CPRC2	1	1	1
Exterior Panel Mounting Support 1	680AC400M1AR	1	1	1
Exterior Panel Mounting Support 2	680AC400M2AR	1	1	1
Frame case	680AC400TLOC2	1	1	1
Side Panel Support	680AC400S23X	1	1	1
Side Panel	680AC400LTRC2	1	1	1
Outlet Socket Support	680AC400S30R	1	1	1
Inlet Socket Support	680AC400S37R	1	1	1
Lower Internal Separation Panel	680AC400S33C2	1	1	1
Upper Internal Separation Panel	680AC400S36C2	1	1	1
Side Support 3	680AC400M3AR	1	1	1
Side Support 4	680AC400M4AR	1	1	1
Frame Case Reinforcement	680AC400S40C2	2	2	2
Frame Case Reinforcement 1	680AC400S51C2	1	1	1
In/Out Cover	680AC400S41C2	2	2	2
Heat-Exchanger Support	680AC400S44X	4	4	4
In/Out Cover 2	680AC400S45C2	2	2	2
Condensate Drain Support	680AC400S46R	1	1	1
Rear Panel	680AC400PSTC2	1	1	1
Lower Rear Panel	680AC400PS1C2	1	1	1
Filter Support	680AC400S49X	4	4	4
SD Switch Support	680AC400S50X	1	1	1
QE Box	680AC400MNAC2	1	1	1
QE Box Support 1	680AC400S34X	1	1	1
QE Box Support 2	680AC400S35X	1	1	1
QE Box door for DMC12	680AC600PTRC2	1	1	1

7.1 TROUBLESHOOTING



The troubleshooting and the eventual checks have to be worked out by qualified personnel. Pay particular attention in case of interventions on the refrigerating circuit. The refrigerating fluid, if under pressure, while expanding could cause freezing burns and serious damage to the eyes, should it get in contact with them.

SYMPTOM

POSSIBLE CAUSE - SUGGESTED ACTION

- ◆ The dryer doesn't start.
 - ⇒ Check for mains failure.
 - ⇒ Verify the electric wiring.
 - ⇒ **ACT 1500-4 – ACT2000-4** - The back panel of the dryer is open (SD door interlock safety-switch has been activated) - make sure that back panel is correctly closed and the SD switch restored.
 - ⇒ The DMC12 “alarm” led is ON - see specific point.

- ◆ The compressor doesn't work.
 - ⇒ Activation of the compressor internal thermal protection - wait for 30 minutes, then retry.
 - ⇒ **Where installed-** Replace the internal thermal protection and/or the start-up relay and/or the start-up capacitor and/or the working capacitor.
 - ⇒ **Where installed-** The pressure switch PA has been activated - see specific point.
 - ⇒ **Where installed-** The pressure switch PB has been activated - see specific point.
 - ⇒ The DMC12 “alarm” led is ON - see specific point.
 - ⇒ If the compressor still doesn't work, replace it.

- ◆ The fan of the condenser doesn't work.
 - ⇒ Verify the electric wiring.
 - ⇒ Pv pressure switch is faulty - replace it.
 - ⇒ **ACT 1500-4 – ACT2000-4** - PV1-PV2 pressure switches are faulty - contact a refrigeration engineer.
 - ⇒ The fan power contactor (see V on the electric diagram) is faulty - replace it.
 - ⇒ The DMC12 “alarm” led is ON - see specific point.
 - ⇒ If the fan still doesn't work, replace it.

- ◆ DewPoint too high.
 - ⇒ The dryer doesn't start - - see specific point.
 - ⇒ The T1 DewPoint probe doesn't correctly detect the temperature - ensure the sensor is pushed into the bottom of copper tube immersion well.
 - ⇒ The refrigerating compressor doesn't work - see specific point.
 - ⇒ The ambient temperature is too high or the room aeration is insufficient - provide proper ventilation.
 - ⇒ The inlet air is too hot - restore the nominal conditions.
 - ⇒ The inlet air pressure is too low - restore the nominal conditions.
 - ⇒ The inlet air flow rate is higher than the rate of the dryer - reduce the flow rate - restore the normal conditions.
 - ⇒ The condenser is dirty - clean it.
 - ⇒ The condenser fan doesn't work - see specific point.
 - ⇒ The dryer doesn't drain the condensate - see specific point.
 - ⇒ The hot gas by-pass valve is out of setting - contact a refrigeration engineer to restore the nominal setting.
 - ⇒ There is a leak in the refrigerating fluid circuit - contact a refrigeration engineer.

- ◆ DewPoint too low.
 - ⇒ The fan is always ON - Pv pressure switch is faulty - replace it.
 - ⇒ The hot gas by-pass valve is out of setting - contact a refrigeration engineer to restore the nominal setting.

- ◆ Excessive pressure drop within the dryer.
 - ⇒ The dryer doesn't drain the condensate - see specific point.
 - ⇒ The DewPoint is too low - the condensate is frost and blocks the air - see specific point.
 - ⇒ Check for throttling the flexible connection hoses.

- ◆ The dryer doesn't drain the condensate.
 - ⇒ The condensate drain service valve is closed - open it.
 - ⇒ The condensate drain strainer is clogged - remove and clean it.
 - ⇒ The drain solenoid valve is jammed - remove and clean it.
 - ⇒ Verify the electric wiring.
 - ⇒ The coil of the condensate drain solenoid valve burned out - replace it.
 - ⇒ The DewPoint is too low - the condensate is frozen - see specific point.
- ◆ The dryer continuously drains condensate.
 - ⇒ The drain solenoid valve is jammed - remove and clean it.
 - ⇒ Try to remove the electric connector on the solenoid valve - if drain stop the electronic instrument is faulty - replace it.
- ◆ Water within the line.
 - ⇒ The dryer doesn't start - see specific point.
 - ⇒ **Where installed** - Untreated air flows through the by-pass unit - close the by-pass.
 - ⇒ The dryer doesn't drain condensate - see specific point.
 - ⇒ DewPoint too high - see specific point.
- ◆ **Where installed**- The P_A high-pressure switch has been activated.
 - ⇒ Check which of the following has caused the activation :
 1. The ambient temperature is too high or the room aeration is insufficient - provide proper ventilation.
 2. The condenser unit is dirty - clean it.
 3. The condenser fan doesn't work - see specific point.
 - ⇒ Reset the pressure-switch pressing the button on the controller itself - verify the dryer for correct operation.
 - ⇒ The P_A pressure switch is faulty - contact a refrigeration engineer to replace it.
- ◆ **Where installed**- The P_B low-pressure switch has been activated.
 - ⇒ There is a leak in the refrigerant fluid circuit - contact a refrigeration engineer.
 - ⇒ The pressure switch restores automatically when normal conditions are restored - check the proper operation of the dryer.
- ◆ The DMC12 "alarm" led is ON.
 - ⇒ The P_A high-pressure switch is activated - see specific point.
 - ⇒ The P_B low-pressure switch is activated - see specific point.
 - ⇒ The electric protection (see Q1 on the electric diagram) of the compressor is activated - restore it and retry.
 - ⇒ The thermal protection (see TV on the electric diagram) inside the fan is activated - wait 30 minutes and retry.
 - ⇒ The electric protection (see Q2 on the electric diagram) of the fan(s) is activated - restore it and retry.

8.1 EXPLODED VIEW-TABLE OF COMPONENTS

Exploded view table of components

1	ACT Heat Exchanger Module	11	Fan guard	21	Top Panel
2	Panel support bracket	12	Fan motor	22	Refrigerant pressure switch P _A
3	Side panel	13	Filter Drier	23	Refrigerant pressure switch P _B
4	Hot gas by-pass valve	14	Solenoid valve body -Cond. Drain	24	Fan
5	Refrigerant pressure switch P _V	15	Solenoid valve coil -Cond. Drain	25	Isolation valve / Strainer
6	Control panel	16	Isolation valve / Strainer	26	Zero Loss Drain-Optional
7	Front panel	17	Base panel	27	Electric box
8	Refrigeration compressor	18	Condenser	28	HP Refrigerant gauge (High-pressure)
9	Capillary tube	19	Rear panel	29	LP Refrigerant gauge (Low-pressure)
10	Fan blade	20	Component Shelf	30	SD Door interlock safety-switch

ACT 600-4 – ACT 1000-4

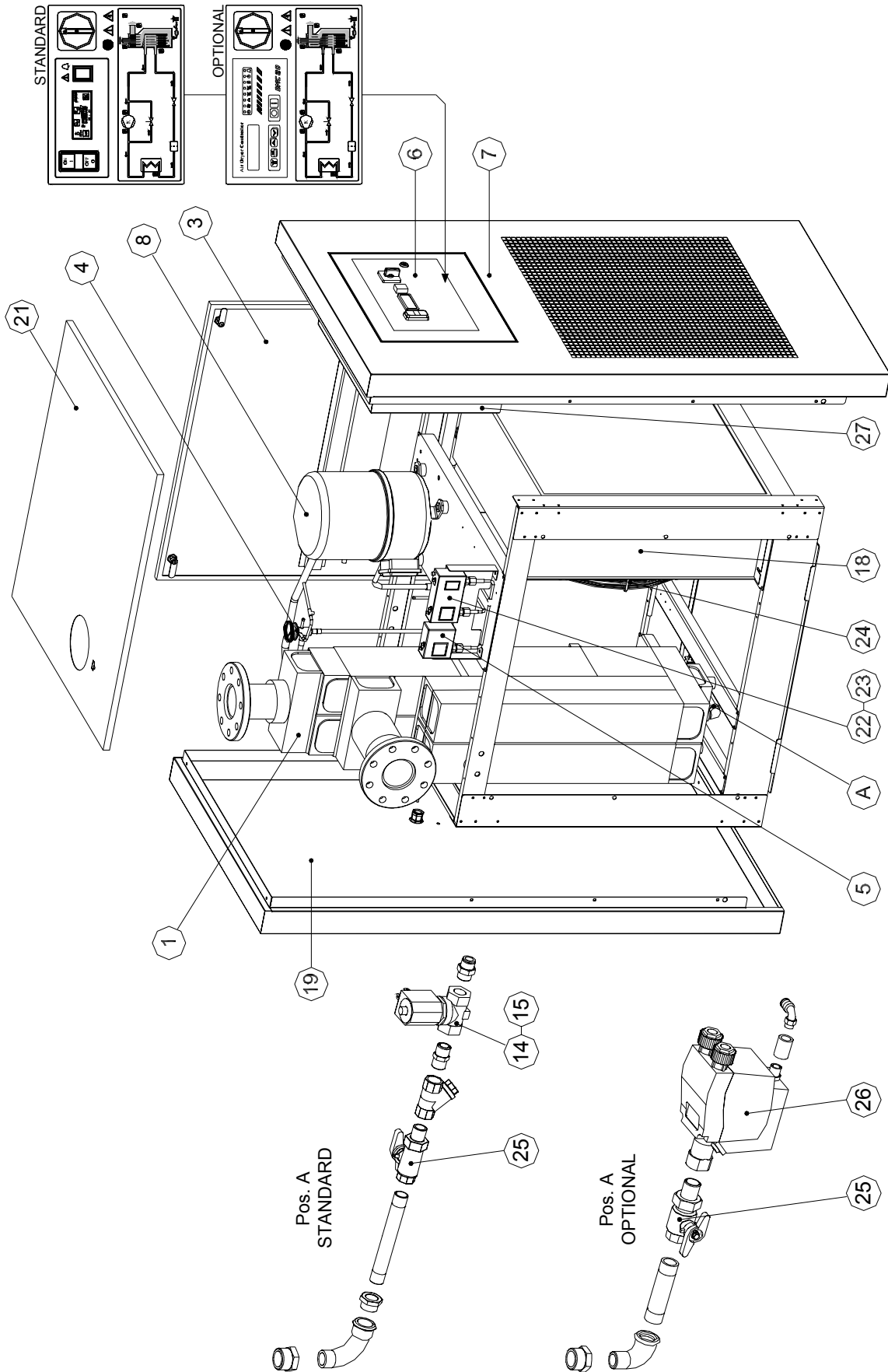

ACT 1500-4 – ACT 2000-4

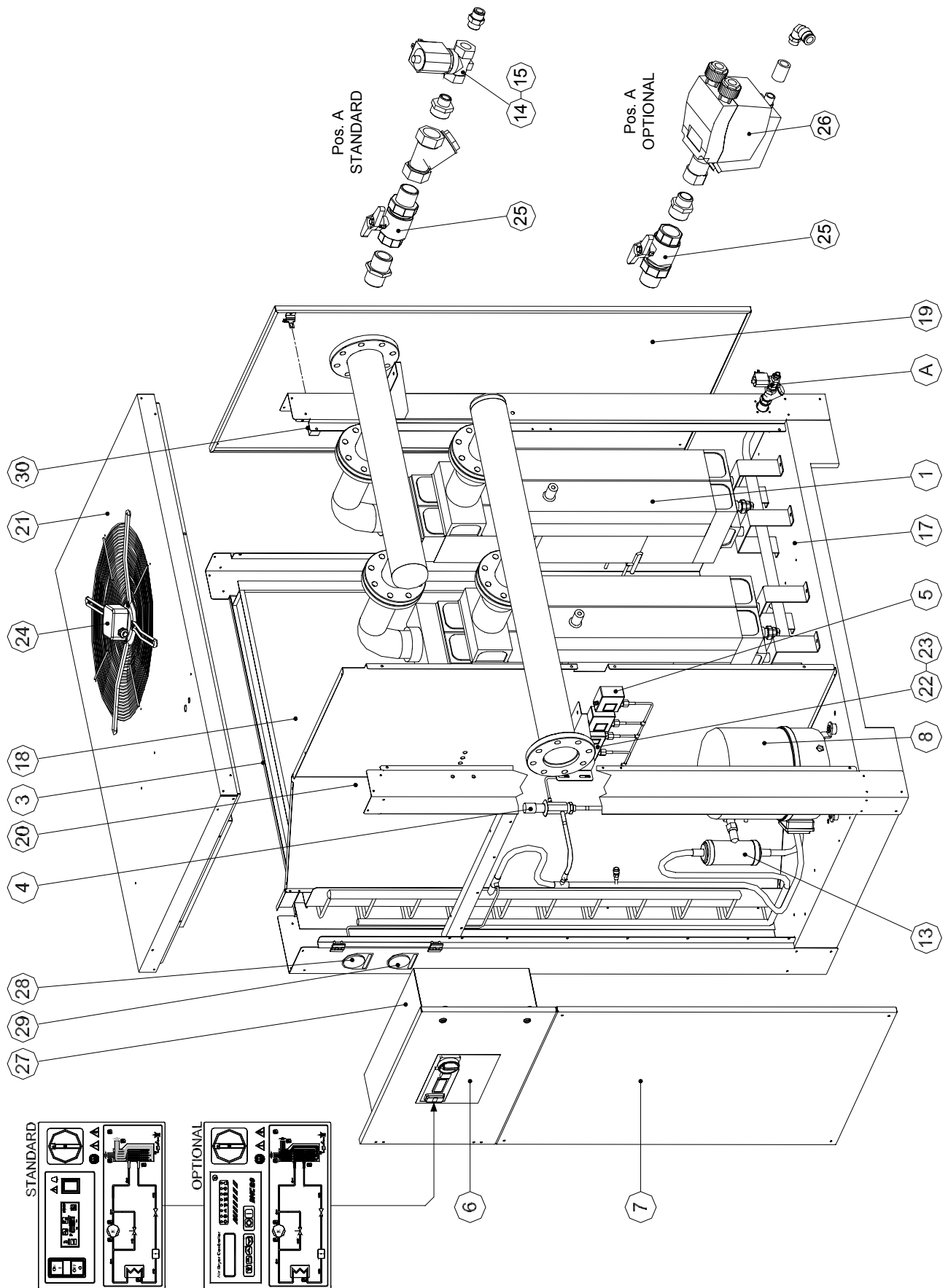



149 Rickey Blvd., Bear, Delaware • TEL. (302) 832-5800 • FAX (302) 832-5900