

# STAGE 1

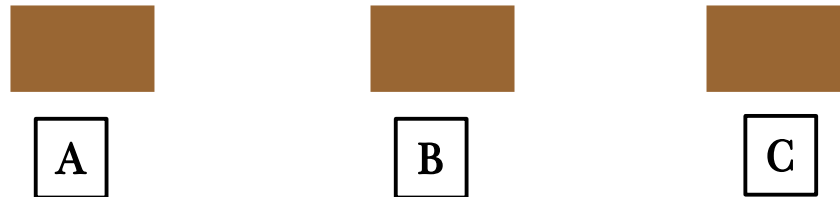
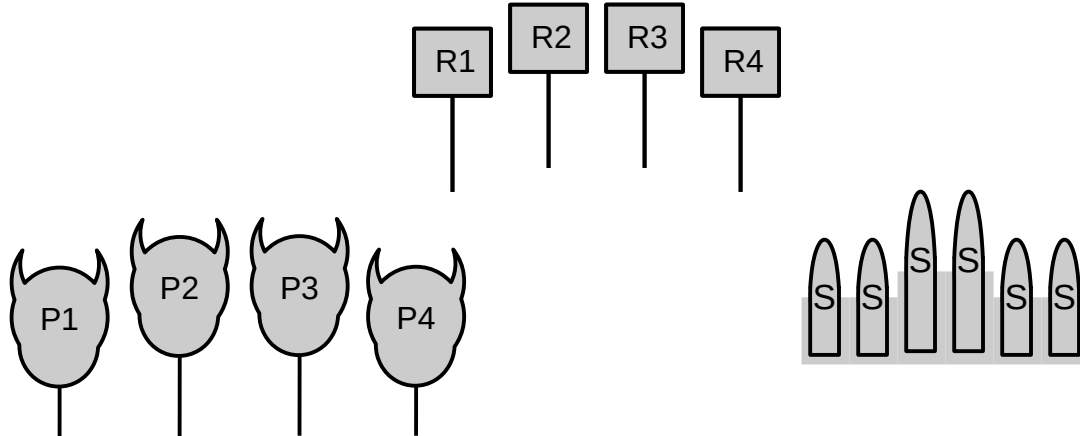

**START:** At any position, at the ready, fingers pinching nose.  
Rifle loaded w/10 rds staged at any position.  
Shotgun open and empty staged at any position.  
Pistols loaded w/5 each and holstered.

**LINE:** “ Get to the stable. “

**AT THE BEEP:** (Guns may be shot in any order, but rifle must not be last.)

At “A” With Pistols: Engage P1-P4 at least once each for a total of 10 rounds.

At “B” With Rifle: Engage R1-R4 as per pistol instructions.

At “C” With Shotgun: Engage the 6 shotgun targets.

# STAGE 2

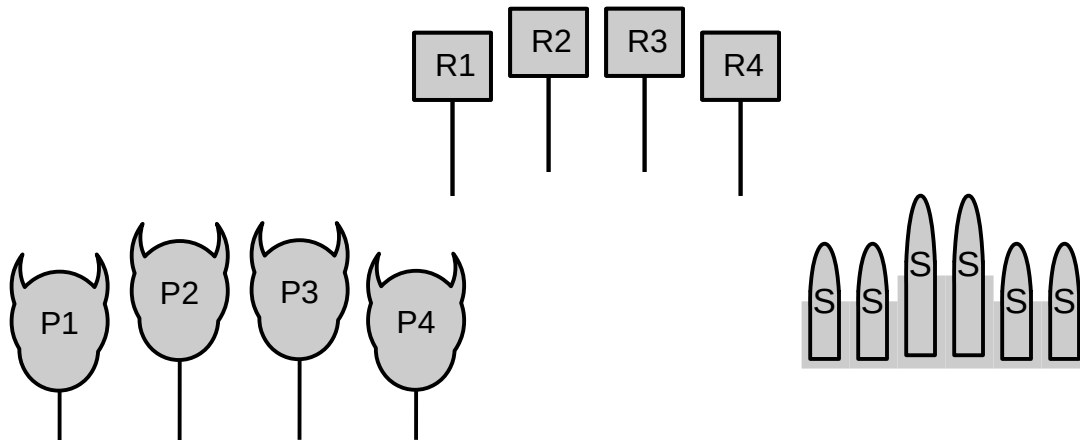

	10 RIFLE	10 PISTOL	6+ SHOTGUN	
--	----------	-----------	------------	--

**START:** At any position, first firearm of choice in hands.  
Rifle loaded w/10 rds staged at any position or in hands.  
Shotgun open and empty staged at any position or in hands.  
Pistols loaded w/5 each and holstered or in hands.

**LINE:** “ Why is the stable always full of outlaws? “

**AT THE BEEP:** (Guns may be shot in any order, but rifle must not be last.)

At “A” With Pistols: Engage P1-P4 in a 2-3-3-2 sweep from either end.

At “B” With Rifle: Engage R1-R4 as per pistol instructions.

At “C” With Shotgun: Engage the 6 shotgun targets.

# STAGE 3

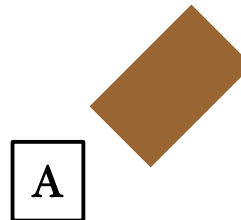
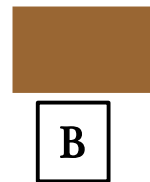
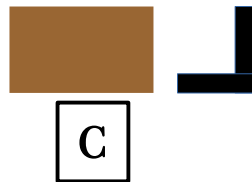
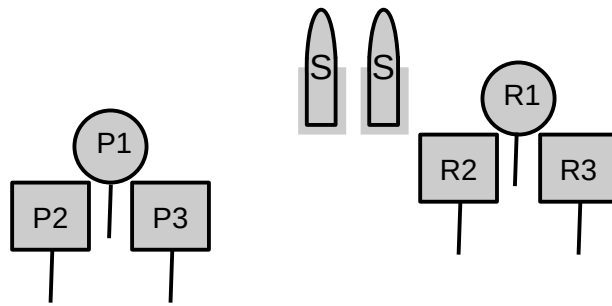

★ 10 RIFLE 10 PISTOL 2+ SHOTGUN ★

**START:** At Position A, rifle loaded w/10 rds in hands.  
Shotgun staged on table at position A.  
Pistols loaded w/5 each and holstered.

**LINE:** “ How much does ammo cost here? “

**AT THE BEEP:**

At “A” With Rifle: Alternate between R1 and R2 for 5 rounds, then repeat using R1 and R3.

At “B” With Shotgun: Engage the 2 shotgun targets.

At “C” With Pistols: Engage P1-P3 per the rifle instructions.

# STAGE 4

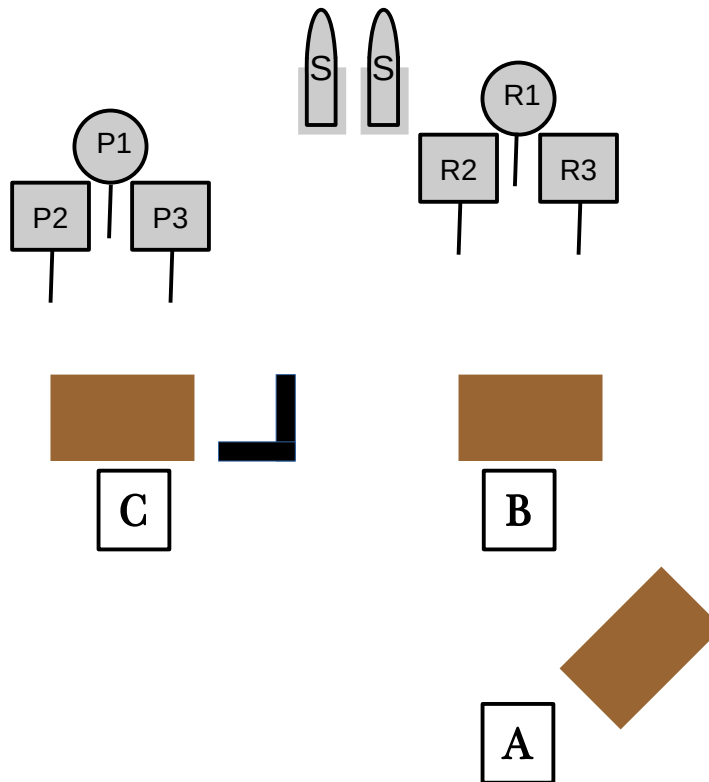

★ 10 RIFLE 10 PISTOL 2+ SHOTGUN ★

**START:** At Position A, rifle loaded w/10 rds in hands.  
Shotgun staged on table at position A.  
Pistols loaded w/5 each and holstered.

**LINE:** “ Can I open a line of credit? “

**AT THE BEEP:**

At “A” With Rifle: Engage rifle R1,R2,R3,R2,R3 or R1,R3,R2,R3,R2. Repeat instruction for second 5 rounds.

From “A to B” With Shotgun: Engage the 2 shotgun targets, but only from one position. All shotgun make ups must be made from the position where they are initially engaged. Make shotgun safe at Position B.

At “C” With Pistols: Engage P1-P3 per the rifle instructions.

# STAGE 5

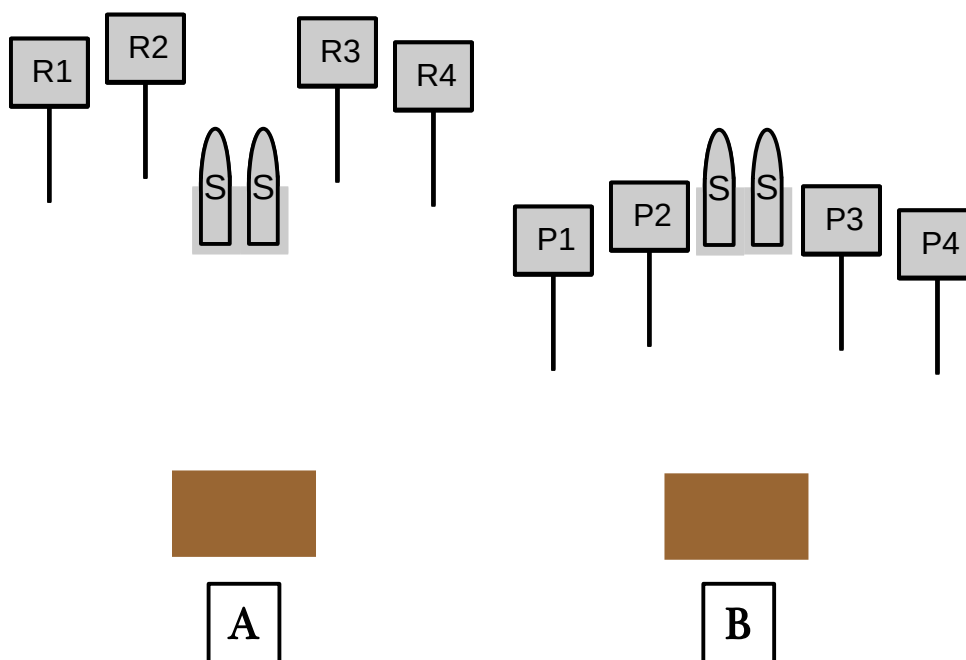

★ 10 RIFLE 10 PISTOL 2+ SHOTGUN ★

**START:** At either position, standing at the ready.  
Rifle loaded w/10 rds staged at any position  
Shotgun open and empty staged at any position.  
Pistols loaded w/5 each and holstered.

**LINE:** “ Is this the 3:10 to Yuma? “

**AT THE BEEP:** (Guns may be shot in ANY order, but rifle must not be last.)

At “A” With Rifle: Engage R1-R4 at least twice each.

At “B” With Pistols: Engage P1-P4 per the rifle instructions.

At “A or B” With Shotgun: Engage 2 shotgun targets.

# STAGE 6

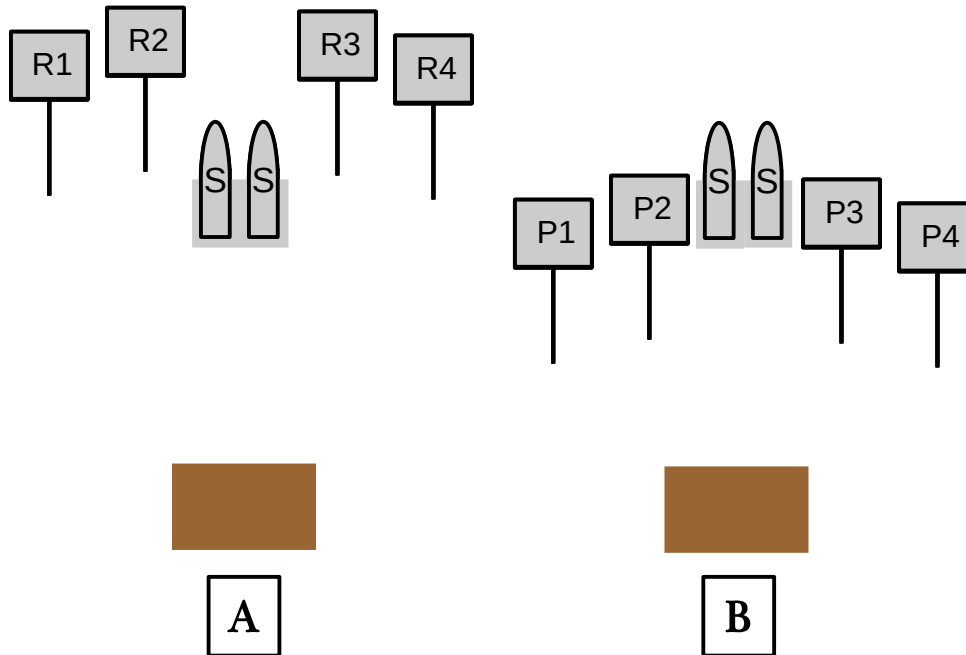

★ 10 RIFLE 10 PISTOL 4+ SHOTGUN ★

**START:** At either position, standing at the ready.  
Rifle loaded w/10 rds staged at any position  
Shotgun open and empty staged at any position.  
Pistols loaded w/5 each and holstered.

**LINE:** “ This train doesn’t stop the whole way. “

**AT THE BEEP:**

At “A” With Rifle: Engage R1-R4 alternating between any two targets for 5 rounds. Repeat instruction using the other two targets for the next 5 rounds.

At “A” With Shotgun: Engage 2 shotgun targets. Move to B then:

At “B” With Shotgun: Engage 2 shotgun targets.

At “B” With Pistols: Engage P1-P4 per the rifle instructions.