

Stage 1

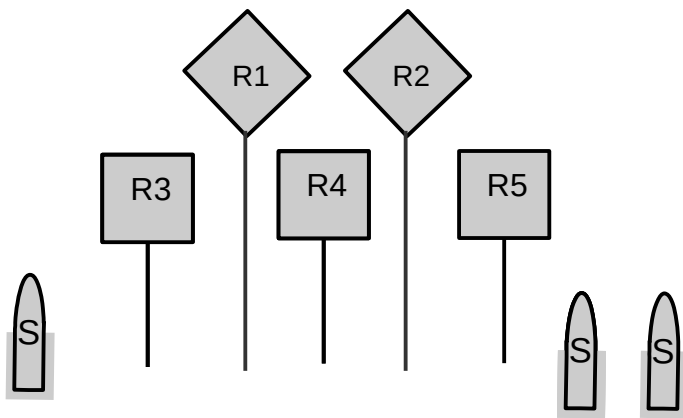

April Showers

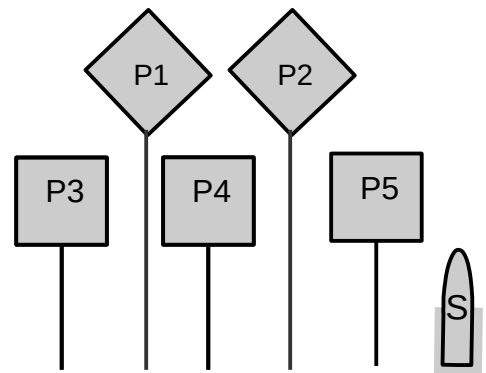

A



B



C



Start: Rifle and Shotgun staged on any table, Pistols holstered.

Position: Hands both touching, but not lifting firearm(s) of choice

Line: It's raining lead! **Order:** Firearms may be shot in any order, but rifle from A, shotgun from B and pistols from C

At the Beep:

At A with the Rifle: Engage rifle targets twice each (round count)

At B with Shotgun: Engage 4 targets till down, any order

At C with Pistols: Same instructions as rifle

Stage 2

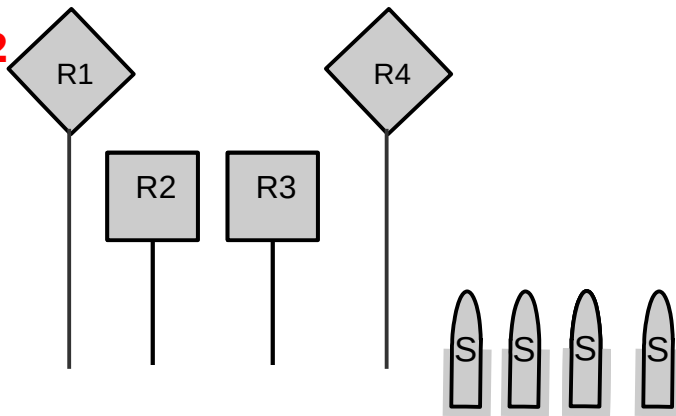

41-14 pretty keen

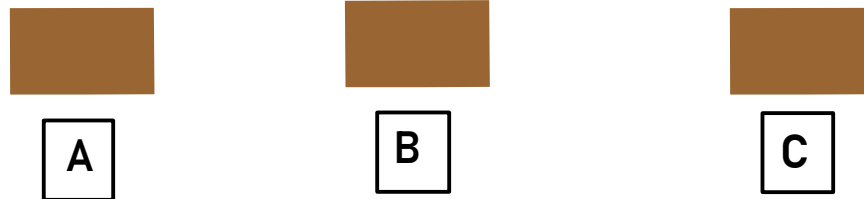
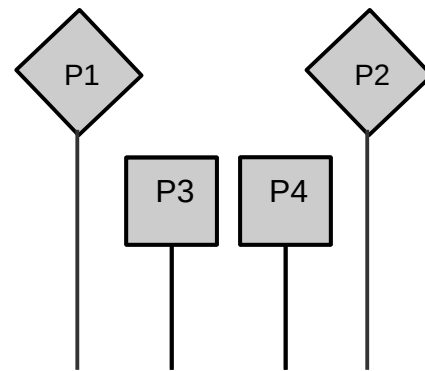

 **10 RIFLE 10 PISTOL 4+ SHOTGUN** 

Start: Rifle and Shotgun staged on any table, Pistols holstered.

Position: Hands both touching hat (or head if hatless)

Line: 41-14! **Order:** Firearms may be shot in any order, but rifle from A, shotgun from B and pistols from C

At the Beep:

At A with the Rifle: Engage rifle targets in a 4-1-1-4 sweep starting on R1 or R4

At B with Shotgun: Engage 4 fallers till down, any order

At C with Pistols: Same instructions as rifle

Stage 3

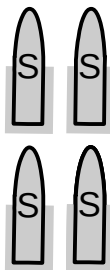
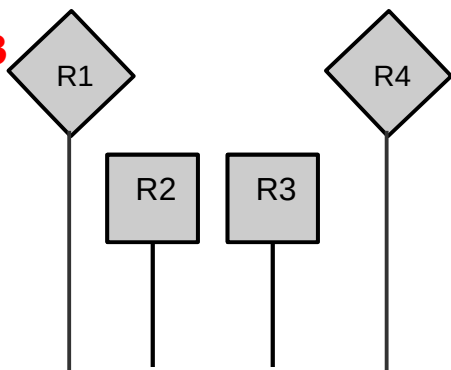

Springtime in Nevada

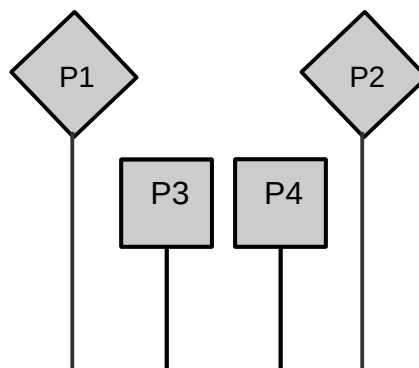

A



B



C



Start: Rifle and Shotgun staged on any table, Pistols holstered.

Position: Hands with 10 fingertips touching the table—may not be touching firearm

Line: I love Nevada! **Order:** Firearms may be shot in any order, but rifle from A, shotgun from B and pistols from C

At the Beep:

At A with the Rifle: Engage rifle targets in a 10 shot single tap Nevada Sweep in either direction starting on R1 or R4

At B with Shotgun: Engage 4 fallers till down, any order—doubles encouraged

At C with Pistols: Same instructions as rifle

Stage 4

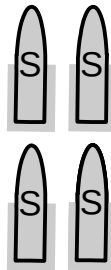
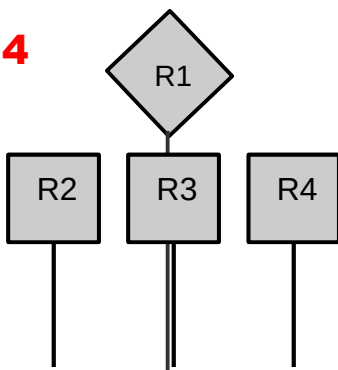

One is the number

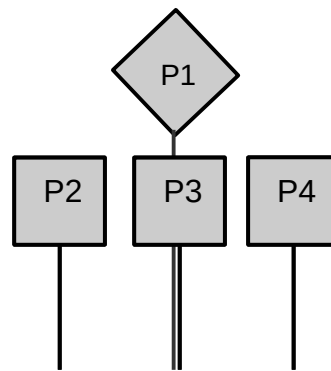

A



B



C



Start: Rifle and Shotgun staged on any table, Pistols holstered.

Position: Firearm of choice in hands

Line: I'm number 1! **Order:** Firearms may be shot in any order, but rifle from A, shotgun from B and pistols from C

At the Beep:

At A with the Rifle: Engage rifle targets in a 10 shot Sunshine Sweep from either direction R1-R2-R2-R1-R3-R3-R1-R4-R4-R1 or R1-R4-R4-R1-R3-R3-R1-R2-R2-R1

At B with Shotgun: Engage 4 fallers till down, any order—doubles encouraged

At C with Pistols: Same instructions as rifle

Note: you start and stop on R1 and P1

Stage 5

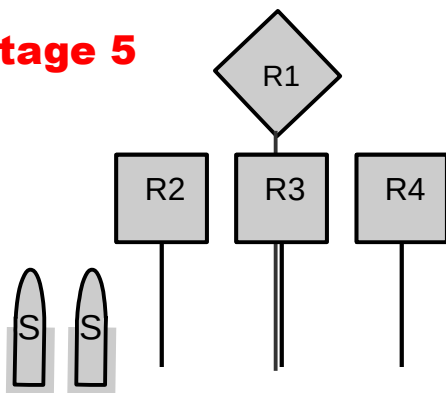

2's and a 4

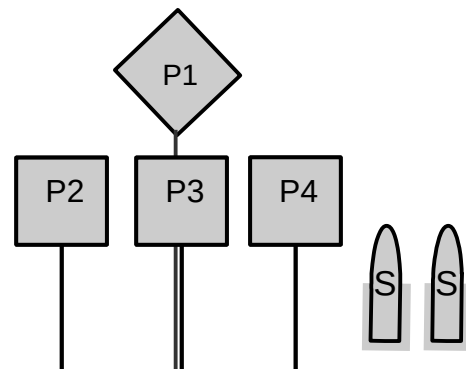

A



~~B~~



C



Start: Rifle and Shotgun staged on any table, Pistols holstered.

Position: SASS Ready, hands hovering above a firearm, but not touching.

Line: Three 2's and a 4 ! **Order:** Firearms may be shot in any order, but rifle from A, shotgun from A and C, and pistols from C

At the Beep:

At A with the Rifle: Engage the three lower rifle targets in either direction in a double tap sweep (R2-R2-R3-R3-R4-R4 or R4-R4-R3-R3-R2-R2) and THEN quad tap the top target (R1-R1-R1-R1).

At A with Shotgun: Engage 2 fallers till down, any order—split shotgun

At C with Shotgun: Engage 2 fallers till down, any order—split shotgun

At C with Pistols: Same instructions as rifle

Note: We will not use position B in this one

Stage 6

Missing is optional

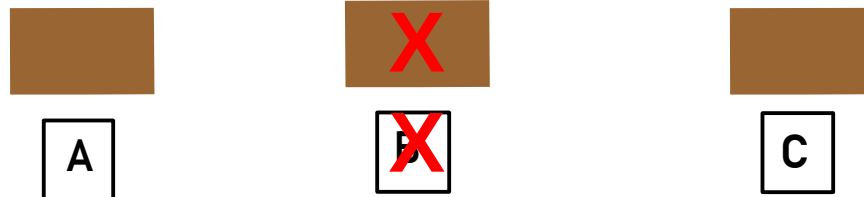
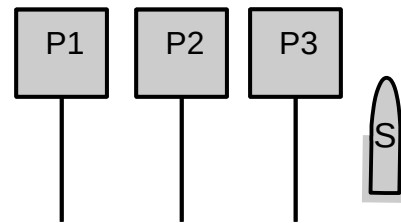
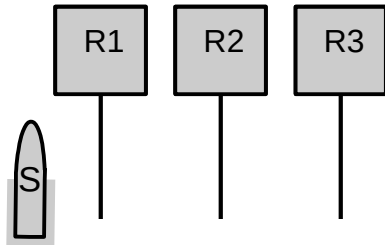

Start: Rifle and Shotgun staged on any table, Pistols holstered.

Position: SASS Ready, hands hovering above a firearm, but not touching.

Line: I don't miss ! **Order:** Firearms may be shot in any order, but rifle from A, shotgun from A and/or C, and pistols from C

At the Beep:

At A with the Rifle: Engage the three rifle targets in a tripple tap sweep starting at either end (R1-R1-R1-R2-R2-R2-R3-R3-R3 or R3-R3-R3-R2-R2-R2-R1-R1-R1) and THEN shoot the rifle side (lefthand) faller with the rifle

At C with Pistols: Same instructions as rifle, engaging the three pistol targets in a tripple tap sweep from either end and THEN shooting the right side faller with the pistol

At A and/or C the shotgun may be used to engage any remaining fallers after the attempt to engage with the rifle or pistol has been made on that faller.

Note: We will not use position B in this one