

# Texas Tone® 12 Owner's Manual

---

## Congratulations!

You are now the proud owner of the Texas Tone 12 guitar Amplifier. This amp packs dynamic vintage tube sound into a compact cabinet – giving you an amp that's small and easy to operate and produces those sweet tube amp sounds and authentic tube tremolo!

Like all Texas Tone Amplifier products, your Texas Tone 12 amplifier is designed by musicians and built using the finest components available. Extensive testing confirms that this amplifier is the absolute best it can be. In order to get the most out of your new amplifier, we strongly urge you to read the information contained in this manual before you begin playing.

And thank you for choosing Texas Tone!



# READ, FOLLOW, HEED, AND KEEP ALL INSTRUCTIONS AND WARNINGS.

CAUTION: RISK OF ELECTRIC SHOCK, DO NOT OPEN

WARNING: TO REDUCE THE RISK OF FIRE OR ELECTRIC SHOCK, DO NOT EXPOSE THIS APPARATUS TO RAIN OR MOISTURE. TO REDUCE THE RISK OF ELECTRIC SHOCK, DO NOT REMOVE REAR COVER. NO USER-SERVICEABLE PARTS INSIDE.

- **WARNING:** THIS AMPLIFIER PRODUCES HIGH DC VOLTAGE (300+ VDC). DO NOT REMOVE THE REAR PANEL OR OPERATE WITH THE REAR PANEL REMOVED. SERVICE TO BE PERFORMED BY QUALIFIED PERSONNEL ONLY.
- DO NOT OPERATE NEAR ANY HEAT SOURCE AND DO NOT BLOCK ANY VENTILATION OPENINGS ON THIS AMPLIFIER. FOR PROPER OPERATION, THIS UNIT REQUIRES 3" (75mm) OF WELL VENTILATED SPACE AROUND HEATSINKS AND OTHER AIR FLOW PROVISIONS IN THE CABINET.
- DO NOT USE THIS AMPLIFIER NEAR SPLASHING, FALLING, SPRAYING, OR STANDING LIQUIDS.
- CLEAN ONLY WITH LINT-FREE DAMP CLOTH AND DO NOT USE CLEANING AGENTS.
- ONLY CONNECT POWER CORD TO A POLARIZED, SAFETY GROUNDED OUTLET WIRED TO CURRENT ELECTRICAL CODES AND COMPATIBLE WITH VOLTAGE, POWER, AND FREQUENCY REQUIREMENTS STATED ON THE REAR PANEL OF THE AMPLIFIER.
- PROTECT THE POWER CORD FROM DAMAGE DUE TO BEING WALKED ON, PINCHED, OR STRAINED.
- UNPLUG THE AMPLIFIER DURING LIGHTNING STORMS OR WHEN UNUSED FOR LONG PERIODS OF TIME.
- ONLY USE ATTACHMENTS, ACCESSORIES, STANDS, OR BRACKETS SPECIFIED BY THE MANUFACTURER FOR SAFE OPERATION AND TO AVOID INJURY.
- WARNING: TO REDUCE THE RISK OF ELECTRIC SHOCK OR FIRE, DO NOT EXPOSE THIS UNIT TO RAIN OR MOISTURE.
- SERVICE MUST BE PERFORMED BY QUALIFIED PERSONNEL.
- OUR AMPLIFIERS ARE CAPABLE OF PRODUCING HIGH SOUND PRESSURE LEVELS. CONTINUED EXPOSURE TO HIGH SOUND PRESSURE LEVELS CAN CAUSE PERMANENT HEARING IMPAIRMENT OR LOSS. USER CAUTION IS ADVISED AND EAR PROTECTION IS RECOMMENDED IF UNIT IS OPERATED AT HIGH VOLUME.
- WARNING: THIS UNIT REQUIRES A SAFETY GROUNDED 120VAC 60Hz OUTLET WIRED TO CURRENT ELECTRIC CODES. THE OUTLET MUST REMAIN ACCESSIBLE.

## Contents

Congratulations! .....	1
READ, FOLLOW, HEED, AND KEEP ALL INSTRUCTIONS AND WARNINGS.....	2
The Texas Tone 12® .....	3
The Front Panel:.....	4
The Rear Panel: .....	6
Important Information about Guitar Amp Vacuum Tubes (Valves): .....	7
Tube Types and Usage: .....	7
Tubes: Why (And When) To Replace Them: .....	7
Driver and Tremolo: .....	8
Survival Tips for Tube Amplifiers: .....	8

## The Texas Tone 12

The Texas Tone 12 captures the dynamic performance and power tube bias tremolo of those famous vintage amps of the 1950s, while adding some unique touches and modern safety and construction methods.

Vintage tube guitar amplifiers suffer from outdated electrical grounding methods and very little clean headroom. Texas Tone amps feature modern grounding techniques, three-prong electrical plugs, and shielded inputs for safe, low-noise operation. Through careful tuning and listening to musicians, the Texas Tone 12 allows the guitarist to get that sweet and creamy tube crunch without splitting your eardrums, and yet still have enough headroom to play those clean fills.

The grid bias tremolo circuit is lush and harmonic, with that “hypnotic slam effect”, not harsh like some optical cut-off type tremolo circuits, and can be switched on and off via the included foot switch. For manual operation, the tremolo circuit is engaged when the foot switch is removed, controllable via the Depth knob, which effectively shuts off the tremolo oscillator when turned down.

The Texas Tone 12 features deep bass response and shimmering highs without being muddy or icepick harsh. Break-up is easily controlled via the guitarist's attack on the strings and the use of your guitar's volume and tone controls. From clean to dirty, this amp allows you to remain in control of your sound. Jazz, country, blues, or rock, you'll be surprised at the variety of tones you can achieve with this amp.

Other features of Texas Tone tube guitar amplifiers:

- Extensive use of MIL-Spec resistors and wiring.
- High-temperature wiring, capacitors, tube sockets, circuit boards and other components.
- Tight-tolerance components.
- Hand wired, with careful attention to lead dress.
- Shielded input signal cables.

Specific Features of the Texas Tone 12:

- Rugged steel chassis.
- Grid bias tremolo – the old kind, deep and rich, and foot switchable.
- An “EQ” tone control that is more independent from the volume control than a typical vintage tube guitar amplifier.
- Jensen 12” C12Q speaker –Well rounded, straightforward tone with tight lows, mid bite and bright highs. Powerful enough for a cranked Deluxe-style amp, it has been used in both single and twin configurations by countless manufacturers including Fender®, Ampeg®, Silvertone® and Supro®, just to name a few.
- High and low gain inputs.

## Block Diagram

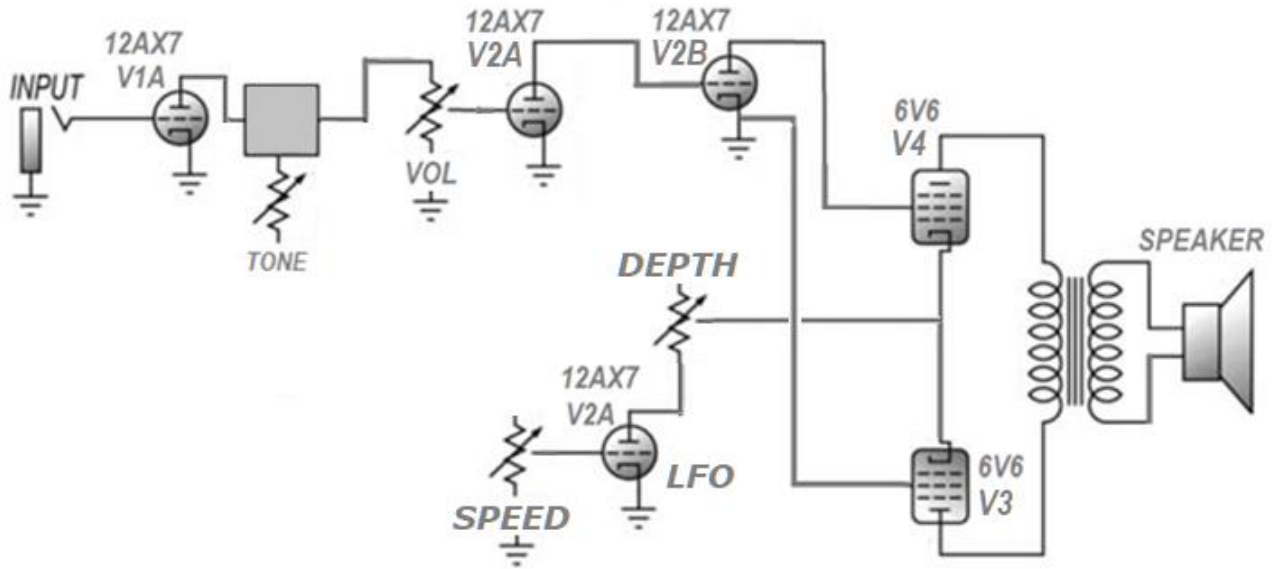

## The Front Panel:

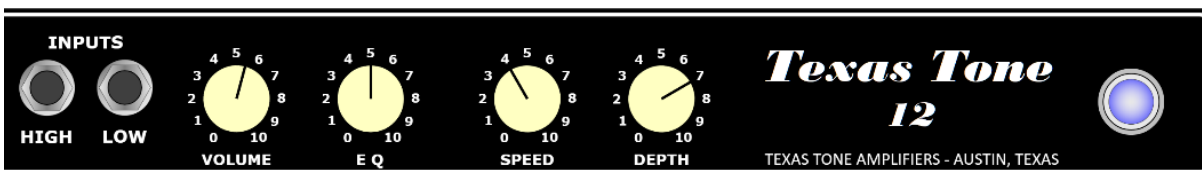

1. **INPUTS:** Two inputs allow you the flexibility to use the high-gain or low-gain input, or to input two guitars.
  - a. **HIGH:** This is the normal, high gain, high impedance (1Meg $\Omega$ ) input. Connect your guitar here by means of a shielded signal cable.
  - b. **LOW:** The second input features a -6dB attenuation compared to Input 1. Use Input 2 as a lower gain input for quieter performance, or when using very high-gain pickups to gain more headroom before the onset of distortion. When both inputs are used at the same time, they offer the same gain characteristics.
2. **VOLUME:** Use this control to adjust the input gain and overall volume level. With the control towards the counter-clockwise position, the gain is low and very little distortion is produced. As you rotate the control clockwise the gain increases, producing more overdrive distortion and a higher output volume level.
3. **EQ (Tone):** The “EQ” Tone control on the Texas Tone 12 offers less interaction with the volume control than a typical vintage amplifier tone control circuit. It’s subtle, and yet offers a wide range of tone control. If you’re used to vintage-type tone control circuits that interact with the volume control, you may be surprised and pleased that this tone control circuit doesn’t raise or lower the volume as you rotate the tone control. As the control knob is rotated clockwise from “1”, more treble frequencies are emphasized.
4. **SPEED:** The Speed control varies the frequency of the tremolo effect, from about 2 cycles per second to about 7 cps as the knob is rotated towards fully clockwise.
5. **DEPTH:** The tremolo depth control allows the user to vary the strength of the tremolo effect, from minimal/off when rotated counter-clockwise, to pronounced when rotated fully clockwise. The tremolo effect may be preset, and turned off and on by the included footswitch.
6. **Indicator lamp:** The lamp will illuminate whenever the amplifier is plugged in to a 120V power source and turned on.

## The Rear Panel:



1. **Fuse:** In the event that the fuse blows or the amplifier will not power on, consult a qualified tube amp technician. Use only a Slow Blow 120V, 2 Amp rated fuse.
2. **POWER switch:** To turn on the amplifier, make sure that the RUN standby switch is off, and then turn on the power switch. After sufficient time for the tubes to warm up, about 15 seconds, turn on the Standby switch. To turn off the amplifier, place this switch in the off position
3. **AC Line Cord:** The grounded power cord should only be plugged into a grounded power outlet that meets all applicable electrical codes and is compatible with 120 Volts AC, 60 Hz power. Do not attempt to defeat the safety ground connection.
4. **RUN (Standby) switch:** The RUN switch controls the high voltage to the tubes of the Texas Tone 12. This switch may also be used to quiet the amplifier for short periods of time.
5. **Speaker connector:** The Texas Tone 12 is shipped with a 1/4" cable connected from the chassis to the internal Jensen 12" C12Q 8Ω speaker.
  - To connect the amplifier to an external speaker cabinet, ensure that the amplifier is powered off, disconnect the 1/4" plug from the amplifier, and use the jack to connect the external cabinet to the amplifier by means of a heavy duty speaker cable terminated with 1/4" plugs. *The minimum impedance for the external speaker is 8 ohms.*
  - **NOTE: Do not power on or operate the amplifier without a speaker plugged in!**
6. **Footswitch connector:** The Texas Tone 12 is shipped with a 1/4" cable connected from the chassis to the tremolo footswitch. This switch allows the guitarist the set the tremolo speed and depth as desired, and then turn the tremolo effect on and off by means of a footswitch. With the footswitch disconnected, the tremolo may be temporarily disabled by turning the Depth control fully counter-clockwise.
7. **Tube sockets** (from right to left):
  - **V1:** Use only a high quality, low noise 12AX7/ECC83/7025 type vacuum tube.
  - **V2:** Use only a high quality 12AX7/ECC83/7025 type vacuum tube. Use of a low-quality tube in the V2 socket will result in a loss of tremolo effect functionality.
  - **V3 & V4:** Use a matched pair of high quality 6V6GT tubes. The power tubes are self-biased, so no bias adjustment is necessary when changing tubes.
  - **V5:** Use only a high quality 5U4GB type rectifier tube. A 5Y3GT may be used, which results in a colder bias. You may or may not like the results. A 5AR4/GZ34 or Solid State replacement is not recommended, as the 6V6 power tubes will be over-biased (100 + %)

## Important Information about Guitar Amp Vacuum Tubes (Valves):

The sound produced by a tube powered amplifier is significantly different from that produced by a solid state amplifier with identical design specifications. When pushed past their limits, solid state devices tend to go immediately into distortion.

Tubes, on the other hand, are non-linear devices that transition more smoothly into distortion, and produce a more musical set of harmonics, the intensity of which can be controlled by the player. This characteristic adds warmth and definition to the sound which has become the hallmark of tube amplifiers. When tubes are driven into clipping, the harmonic overtones can be both sweet and pleasing or intense and penetrating, depending on the musician's musical taste and playing technique.

Modern application engineers have designed a number of outstanding solid-state amplifiers that sound quite good. Some use modeling circuitry which enables them to simulate the distortion characteristics of a tube amplifier. Since the response of tubes is both dynamic and non-linear, the true range of characteristics of tube amplifiers can only be approximated. Modern tube amplifiers such as Texas Tone® amps, offer that classic, dynamic vintage sound in today's contemporary market.

### Tube Types and Usage:

Preamp tube circuits amplify the signal from your instrument and shape the sound, and they can often be microphonic (mechanically pick up and transmit external noises). Since these tubes are used in the critical first stages of a tube amplifier's circuitry, it is very important to use high-quality, low noise/low microphonic tubes for this application. Although tubes of this quality may typically cost more than standard tubes, the improvement in performance is worth the investment, and in some cases, critical.

Preamplifier tubes are also used to drive the power tubes. The power tubes convert the low-level, conditioned signal from the preamplifier into a level that is sufficient to drive the speakers. There are several types of power tubes available, each of which offers a different performance/sound characteristic. The 6V6 tubes used in the Texas Tone 12 produce a creamy sound with nice distortion. Some tubes are available in matched sets. These tubes have been extensively tested for optimum performance and longevity. Matched sets of power tubes are highly recommended.

### Tubes: Why (And When) To Replace Them:

Tubes are made up of a number of fragile mechanical components that are vacuum-sealed in a glass envelope. A tube's longevity is based on a number of factors, including how hard and often the amplifier is played, vibration from the speakers, road travel, repeated set up and tear down, etc. Any time you notice a change in your amplifier's performance, check the tubes first.

If it's been a while since the tubes were replaced and the sound from your amplifier lacks punch, fades in and out, loses highs or lows or produces unusual sounds, the power tubes may need to be replaced. If your amplifier squeals, makes noise, loses gain, starts to hum, lacks dynamic sensitivity, or feels as if it is working against you, the preamplifier tubes may need to be replaced.

The power tubes are subjected to considerably more stress than the preamplifier tubes. Consequently, they almost always fail/degrade first. If deteriorating power tubes aren't replaced they will ultimately fail. Depending on the failure mode, they may even cause severe damage to the audio output transformer and/or other components in the amplifier. Replacing the tubes before they fail completely has the potential to save you time, money and unwanted trouble. Since power tubes work together in an amplifier, it is crucial that they be replaced by a matched set. If you're on the road a lot, we recommend that you carry a spare matched set of replacement power tubes and their associated driver tubes.

After turning off the power and disconnecting the amplifier from the power source, carefully check the tubes (in bright light) for cracks or white spots inside the glass or any other apparent damage. Then, with the power on, view the tubes in a dark room. Look for preamplifier tubes that do not glow at all or power tubes that glow excessively red.

### Driver and Tremolo:

The driver tube determines the shape and amplitude of the signal applied to the power tubes and has to work almost as hard as the power tubes. **NOTE:** The 12AX7 driver tube in the Texas Tone 12 also controls the tremolo circuit. Replacing this tube with a 12AT7, 12AU7, or 12AY7 type tube will result in a loss of tremolo effect.

You can check your preamplifier tubes for microphonics by turning the amplifier on, turning up the gain and tapping lightly on each tube with a chop stick, or other light wooden dowel. You will be able to hear the tapping through your speakers, which is normal. It is not normal for a tube to ring like a bell after it's tapped. If it does ring then it's microphonic and should be replaced. Remember to use only high quality, low microphonic tubes in the preamplifier section. Even though power tubes are rarely microphonic, you should check them anyway. The power tubes can be checked for microphonics just like pre-amp tubes.

### Survival Tips for Tube Amplifiers:

To prolong tube life, observe these tips and recommendations:

- Make sure the speaker(s) are properly connected prior to turning on the amplifier.
- Allow the amplifier to warm up to room temperature before turning it on. The heat generated by the tube elements can crack the cold glass housing.
- After playing the amplifier, allow sufficient time for it to properly cool down prior to moving it. A properly cooled amplifier prolongs tube life due to the internal components being less susceptible to the damage caused by vibration.
- Match the impedance of your speaker cabinet(s) to your amplifier. Improper impedance matching will contribute to early tube degradation and may cause premature tube failure.
- Replace the output tube(s) before the performance degrades or the tubes fail completely. Replace the tube(s) on a regular basis (at least once per year or as often as every 4 to 6 months if you play long and hard every day).

- If the locating notch on the base of a power tube breaks off, replace the tube. This significantly reduces the risk of damaging your amplifier by incorrectly inserting the tube.
- Protect the amplifier from dust and moisture. If liquid gets into the amplifier proper, or if the amplifier is dropped or otherwise mechanically abused, have it checked out at an authorized service center before using it.
- Proper maintenance and cleaning in combination with routine checkups by your authorized service center will insure the best performance and longest life from your amplifier.

**CAUTION:** Tube replacement should be performed only by qualified service personnel who are familiar with the dangers of hazardous voltages that are typically present in tube circuitry.

### **TEXAS TONE 12 TECHNICAL SPECIFICATIONS:**

Output Power Rating	12W RMS, 8 Ohm load
Gain:	65Db Typical
“EQ” Tone Control	Wide-range High pass/Low pass
Speaker	12”, 35W Jensen C12Q, 8Ω, 1.25” copper voice coil, 15oz ceramic magnet, 94.6 dB sensitivity, 87.3 Hz resonant frequency.
Preamp Tubes	2 x ECC83S/12AX7, JJ Electronic
Power Tubes	6V6S JJ Double Mica matched pair
Rectifier Tube	5U4GB JJ Electronic
Power Requirements	120VAC, 60Hz
Size and Weight	17-1/8” H x 21” W x 9-1/2” D, 31 lbs.

**The Texas Tone 12 is covered with a durable Tolex material: wipe it clean with a lint-free cloth. Never spray cleaning agents onto the cabinet. Avoid abrasive cleansers which would damage the finish.**

*Specifications and information in this manual are subject to change without notice.*