



# Rules for Horse Driving Trials 2026





[www.harnessstuff.co.uk](http://www.harnessstuff.co.uk)

Specialists in carriage driving harness and accessories  
We understand your needs  
Knowledgeable unbiased advice always available



IDEAL EQUESTRIAN

Proud sponsors of:  
BC Driver of the Year  
Senior Driver of the Year  
Anna Grayston Carriage Driver  
Emma Massingale Horse Trainer



We have developed an app just  
for carriage drivers. Scan the QR code to download  
or visit Apple or Android App Store



[www.harnessstuff.co.uk](http://www.harnessstuff.co.uk) tel. 07963836968 email. [hello@harnessstuff.co.uk](mailto:hello@harnessstuff.co.uk)

## CONTENTS

|  |    |
|--|----|
| Preamble .....   | 5  |
| Colour Coding and Abbreviations.....                                   | 6  |
| Changes .....  | 7  |
| BRITISH CARRIAGEDRIVING Mission Statement & Objectives .....           | 8  |
| CHAPTER I - General Rules & Regulations.....                           | 10 |
| Article 900    National Rules.....                                     | 10 |
| Conduct and Social Licence to Operate .....                            | 10 |
| Welfare of the Horse .....   | 10 |
| BC Code of Conduct.....  | 13 |
| FEI Code of Conduct .....  | 17 |
| Officials Code of Ethics .....   | 17 |
| Code of conduct for BC Coaches .....                                   | 19 |
| Safety & Safeguarding .....  | 20 |
| CHAPTER II – STRUCTURE OF COMPETITIONS .....                           | 21 |
| Article 901    Categories and Levels.....                              | 21 |
| CHAPTER III – CLASSIFICATION.....                                      | 22 |
| Article 902    Competitions.....                                       | 22 |
| Article 903    Events .....  | 22 |
| Article 904    Equality of Scores .....                                | 22 |
| Article 908    Names of Horses.....                                    | 22 |
| Article 910    Official Results.....                                   | 22 |
| Article 911    Principles .....  | 22 |
| CHAPTER IV -ELIGIBILITY.....   | 24 |
| Article 912    Minimum Age drivers and grooms .....                    | 24 |
| Article 913    Membership .....  | 25 |
| Article 915    Hors Concours .....                                     | 25 |
| Article 916    Entries .....   | 26 |
| CHAPTER V – DRIVERS AND GROOMS .....                                   | 27 |
| Article 928    Dress, Safety and Driving Aid.....                      | 27 |
| CHAPTER VI - HORSES.....   | 28 |
| Article 929    Age of Horses .....                                     | 28 |
| Article 930    Height .....  | 28 |
| Article 931    Number of Horses .....                                  | 28 |
| Article 932    Special Conditions.....                                 | 28 |
| Article 933    Welfare of the Horse (Abuse of Horses and Doping) ..... | 28 |
| Article 935    Examination and Inspection of Horses.....               | 29 |
| CHAPTER VII – CARRIAGES AND HARNESS.....                               | 30 |
| Article 937    Weights and Dimensions.....                             | 30 |

|  |  |    |
|--|--|----|
| Article 938  | Equipment .....                                      | 31 |
| Article 939  | Tyres.....   | 31 |
| Article 940  | Harness, Carriage and Horses.....                    | 32 |
| Article 941  | Advertising on carriages, harness and clothing ..... | 34 |
| Article 942  | Safety .....   | 34 |
| CHAPTER VIII - CONDITIONS FOR PARTICIPATION .....            |  | 36 |
| Article 943  | Participation .....                                  | 36 |
| Article 944  | Identification Number .....                          | 36 |
| Article 945  | Outside Assistance.....                              | 37 |
| CHAPTER X – DECLARATION OF STARTERS – ORDER OF STARTING..... |  | 38 |
| Article 948  | Starting Order .....                                 | 38 |
| CHAPTER XI – DRIVEN DRESSAGE.....                            |  | 39 |
| Article 949  | General.....   | 39 |
| Article 950  | The Arena .....                                      | 39 |
| Article 951  | Driven Dressage Tests .....                          | 39 |
| Article 952  | Conditions .....                                     | 39 |
| Article 953  | Judging .....  | 39 |
| Article 954  | Movements and their descriptions .....               | 40 |
| Article 955  | General impression .....                             | 42 |
| Article 956  | Scoring.....   | 43 |
| Article 957  | Summary of Driven Dressage Penalties.....            | 44 |
| Article 958  | Classification.....                                  | 45 |
| CHAPTER XII - MARATHON .....                                 |  | 46 |
| Article 959  | General.....   | 46 |
| Article 960  | The Course .....                                     | 46 |
| Article 961  | Obstacles in Section B .....                         | 48 |
| Article 962  | Inspection of the Course .....                       | 49 |
| Article 963  | Times.....   | 50 |
| Article 964  | Penalties on the Marathon Course .....               | 51 |
| Article 965  | Obstacle Penalties.....                              | 52 |
| Article 966  | Judges.....  | 53 |
| Article 967  | Officials.....                                       | 54 |
| Article 968  | Classification.....                                  | 55 |
| Article 969  | Summary of Penalties in Marathon.....                | 56 |
| CHAPTER XIII – CONES .....                                   |  | 58 |
| Article 970  | General.....   | 58 |
| Article 971  | Competitions .....                                   | 58 |
| Article 972  | The Course.....                                      | 58 |
| Article 973  | Obstacles .....                                      | 58 |

|              |  |    |
|--------------|--|----|
| Article 974  | Cones Competition Summary .....  | 61 |
| Article 975  | Judging Cones Competition .....  | 62 |
| Article 981  | Summary of Penalties in Cones .....  | 65 |
| CHAPTER XIV  | Officials .....  | 67 |
| Article 984  | Conflicts of Interest .....  | 67 |
| Article 985  | Eligibility of Officials .....   | 67 |
| Article 986  | Judges.....  | 67 |
| Article 988  | Technical Delegate .....   | 68 |
| Article 989  | Course Designers .....   | 68 |
| Article 991  | Veterinary and Medical Cover .....   | 69 |
| Article 995  | Safety and Safeguarding .....  | 69 |
| Article 996  | Appeal Committee .....   | 69 |
| ANNEXES..... |  | 70 |
| ANNEX 1      | Diagram of the 100m x 40m Driven Dressage arena .....                          | 70 |
| ANNEX 2      | Cones: Closed multiple obstacles .....   | 71 |
| ANNEX 4      | Cones: The Bridge.....   | 82 |
| ANNEX 5      | Cones: Alternative Options .....   | 83 |
| ANNEX 6      | Cones: Oxer .....  | 84 |
| ANNEX 9      | Organisation of British Carriagedriving Affiliated Events.....                 | 85 |
| ANNEX 11     | Horse Passports.....   | 87 |
| ANNEX 14     | Objections and Appeals at National Events.....                                 | 88 |
| ANNEX 15     | General Regulations for all British Carriagedriving Horse Driving Trials ..... | 89 |
| ANNEX 16     | Class Structure, eligibility and Progression .....                             | 90 |
|              | Gateway.....   | 91 |
|              | Pre Novice .....   | 93 |
|              | VSE (very small equines).....  | 93 |
|              | Small Equines .....  | 94 |
|              | National Novice Single Classes .....   | 94 |
|              | Open Singles Classes.....  | 94 |
|              | Advanced Singles Classes .....   | 95 |
|              | Pair Classes .....   | 95 |
|              | Advanced Classes .....   | 95 |
|              | Tandem Classes.....  | 95 |
|              | Four in Hand Classes.....  | 95 |
|              | Young Drivers.....   | 95 |
|              | Drivers with Disabilities .....  | 96 |
|              | National Championships and Points Leagues .....                                | 96 |
|              | International.....   | 97 |
| ANNEX 17     | Hard Hat Standards .....   | 98 |

## PREAMBLE

This book contains the British Carriagedriving rules for Horse Driving Trials effective from 1 January 2026. As from this date, all other texts covering the same matter issued previously are superseded.

If an incident occurs that is not covered by a specific rule the President of the Jury and Technical Delegate will determine any penalty that may be necessary. Any incident will be considered in 'The Spirit of the Sport'. They will report the specific incident to the British Carriagedriving office in their post event report for consideration by the Rules Committee.

British Carriagedriving is committed to genuine equality of opportunity. This means that we treat all members fairly irrespective of ethnic origin, sex, marital status, sexual orientation, age, religion or disability.

Throughout this publication the words horse and pony are used interchangeably to mean the equine. References to the masculine are not gender specific; the singular the plural; unless otherwise stated in a specific rule.

British Carriagedriving Affiliated Clubs may make such changes to the rules as they see fit to facilitate safe and efficient running of their events, as long as such changes are in the spirit of the sport and do not compromise any of:

- Welfare of the Horse
- Health and Safety
- Social Licence to Operate
- Safeguarding

These rules are intended to standardise Horse Driving Trials Events in the United Kingdom as far as is possible, so that the conditions at driving trials events are fair and similar for all drivers nationwide.

## COLOUR CODING AND ABBREVIATIONS

The following sections are identified by coloured page footers:

DRIVEN DRESSAGE

MARATHON

CONES

OFFICIALS

ANNEXES

### Abbreviations used in these rules:

|     |   |
|-----|---|
| BC  | British Carriagedriving   |
| CD  | Course Designer   |
| DWD | Drivers with Disabilities   |
| HC  | Hors Concours – ‘outside the competition’ an entry type not to be placed in a competition/event |
| OC  | Organising Committee  |
| POJ | President of the Jury   |
| SE  | Small Equine  |
| TD  | Technical Delegate  |
| U25 | Under 25  |
| VSE | Very Small Equine   |

## CHANGES

This section describes changes to these rules from previous versions.

1. The 2026 BC Rules recombine the separate rulebooks used in 2024 and 2025, bringing all the rules information into one place including VSE, SE, Gateway and other classes.
2. The existing BC Mission statement is included
3. A new Officials Code of Ethics is included
4. A new Code of Conduct for BC Coaches is included
5. Clarification: Before entering their first event the driver must complete an Introductory Safety and Competence Assessment and forward a copy of this to the organiser. Annex 16 4.2
6. *Back* protectors are no longer acceptable, *body* protectors must be worn where required.
7. 928.7.1 Properly secured hard hats must be worn by all people on the carriage or riding *at all times at an event*. Hard hats must be to an appropriate standard and it is recommended that no recording device is fitted to them. See Annex 17.
8. 933.1.1c Forbids inappropriate use of a driving aid and hitting the carriage or shouting excessively at the horse in an attempt to make it go faster
9. 937.5.5 Clarification: Grooms of 2 wheel carriages following the marathon on the ground are not obliged to wear body protectors (but it is recommended)
10. 974.1 Open pony cones speed is reduced to 240 m/min from 245 m/min.
11. 974.1 VSE and Small Equine cones width is reduced to 145cm.
12. 974.1 Novice Pony and Horse cones width is reduced to 160 from 165
13. 974.1 Pony Tandem cones width is reduced to 160 from 165
14. The Serpentine (a straight line of 4 single cones) is removed.
15. 975.3.2 Clarify that a driver is eliminated for driving a cone which has already been driven.
16. 942.10 The safety check for Novice, Very Small Equine, Small Equines, Children, Juniors, Young Drivers, Drivers with Disabilities, Pre-Novice and Gateway classes is also required before cones where cones does not follow immediately after the previous competition (e.g. 3 day events)
17. 961.4.4 The distinction between light mobile and heavy mobile obstacles is removed. All mobile obstacles have a minimum compulsory gate width of 3m and all mobile elements must have a knockdown.
18. Annex 14. Restored the 30 minute objection rule
19. Annex 16. VSE, SE, Novice and Open requirement to move from test A to test B after 2 wins changes to having to move at the end of the season
20. Annex 16. Young driver progression to International events is at the discretion of the Chef d'Equipe of YD and the Chef's committee

The aim of British Carriagedriving is to increase the quality and quantity of horse driving trials at all levels in the UK.

### Primary Objectives

#### Participation

To increase participation and enjoyment in horse driving trials by:

- Inspiring more adults and children to go driving more often
- Increasing the satisfaction of participants and volunteers to sustain and grow driving participation

#### Safety and welfare

- To ensure the welfare of horses involved in the sport
- Work with all individuals and organisations associated with horse driving trials in conjunction with the appropriate agencies so that the number of preventable incidents and accidents are reduced

#### Representation

To represent recreational horse driving trials freedoms and responsibilities:

- to maintain British Carriagedriving's position as an undisputed upholder of recreational drivers' freedoms and responsibilities
- to protect drivers' rights to enjoy their activity by working with relevant local, regional, national, European and international organisations
- to promote responsible and sustainable horse driving trials, in safety and in harmony with the environment and other land users in UK

#### Performance

To raise standards:

- of horse driving trials, drivers, grooms, coaches/trainers and officials in order to enhance competition and for the overall enjoyment of horse driving trials throughout the UK
- to achieve international competitive success at significant international championships and in world rankings
- of education
- to maintain British Carriagedriving as the primary source of horse driving trials information and training programmes

#### Membership

To expand the membership base:

- to sustain and develop the membership base of British Carriagedriving
- to enhance British Carriagedriving's image
- to provide regular communication with members

### Associated Objectives

#### Widening Access

- To ensure that British Carriagedriving services and programmes are inclusive and accessible to all, including under-represented groups
- Volunteering - to develop a well-informed, skilled and motivated network of volunteers
- To promote horse driving trials and deliver British Carriagedriving's programmes at club, regional and national level

- To encourage more British Carriagedriving members to become involved with the running of the Association and its programmes at all levels

## **Communications**

To raise the profile of British Carriagedriving and maintain British Carriagedriving's position as the recognised 'voice of competitive driving' in the UK:

- to understand and represent the views of the horse driving trials community
- to seek wider recognition by key audiences of British Carriagedriving's views, commitment and achievements
- to liaise with associated industries to promote common objectives

## **Financial**

To be financially strong:

- to achieve an annual operating surplus
- to increase turnover from subscription, trading and sponsorship income
- to minimise the working capital requirements for trading operations
- to grow the accumulated fund to the equivalent of 9 months administrative expenditure.

## CHAPTER I - GENERAL RULES & REGULATIONS

### ARTICLE 900 NATIONAL RULES

1. These Rules are intended to standardise Horse Driving Trials Events in the United Kingdom as far as is possible, so that the conditions at such events are fair and similar for all drivers.
2. Organising Committees at National Events and events organised by clubs affiliated to British Carriagedriving may decide to hold one, two or three day events.
3. Qualifying events for the National Championships must consist of all three competitions, unless they have been granted express approval by Council. These shall be: Driven Dressage, a Marathon and Cones.

### CONDUCT AND SOCIAL LICENCE TO OPERATE

Launched in March 2024, the **Charter for the Horse** is a pledge to be adopted by all across the equestrian sector to underpin our commitment to safeguarding the mental and physical wellbeing of our equids. All 19 of the British Equestrian member bodies have signed up to the Charter and we will collectively work towards the highest standards in the six key areas of:

- Empathy
- Care
- Respect
- Consideration
- Ethics
- Learning

### WELFARE OF THE HORSE

The following Code of Conduct has been prepared by the FEI for inclusion on all schedules for international Events, it has been adapted briefly to represent a Code for use by the BEF and its members more widely.

The FEI, BEF and its members expect all those involved in international equestrian sport to adhere to the FEI Code of Conduct and to acknowledge and accept that at all times the welfare of the horse must be paramount and must never be subordinated to competitive or commercial influences.

1. At all stages during the preparation and training of competition horses, welfare must take precedence over all other demands. This includes good horse management, training methods, farriery and tack, and transportation. More specifically:
  - a. Stabling and feeding must be compatible with the best horse management practices. Clean and good quality hay, feed and water must always be available.
  - b. Horses must only undergo training that matches their physical capabilities and level of maturity for their respective disciplines. They must not be subjected to methods which are abusive or cause fear.
  - c. Foot care and shoeing must be of a high standard. Tack and harness must be designed and fitted to avoid the risk of pain or injury.
  - d. During transportation, Horses must be fully protected against injuries and other health risks. Vehicles must be safe, well ventilated, maintained to a high standard, disinfected regularly and driven by competent personnel. Competent handlers must always be available to manage the Horses.

- e. All journeys must be planned carefully, and Horses allowed regular rest periods with access to food and water in line with current FEI guidelines.
2. Horses and drivers must be fit, competent and in good health before they are allowed to compete. This encompasses medication use, surgical procedures that threaten welfare or safety, pregnancy in mares and the misuse of aids. More specifically:
  - a. Any surgical procedures that threaten a competing Horse's welfare or the safety of other Horses and/or Drivers must not be allowed.
  - b. Mares must not compete after their fourth month of pregnancy or with foal at Foot.
  - c. Abuse of a Horse using natural riding aids or artificial aids (e.g. whips, spurs, etc.) will not be tolerated.
  - d. A horse may not compete more than once at any event excepting Gateway and dressage where they may compete twice. (Maximum of 8 obstacles at any event)
3. Events must not prejudice horse welfare. This involves paying careful attention to the competition areas, ground surfaces, weather conditions, stabling, site safety and fitness of the horse for onward travel after the event. More specifically:
  - a. Horses must be trained and compete on suitable and safe surfaces. All obstacles and competition conditions must be designed with the safety of the Horse in mind.
  - b. All ground surfaces on which Horses walk, train or compete must be designed and maintained to reduce factors that could lead to injury.
  - c. Competitions must not take place in extreme weather conditions that may compromise welfare or safety of the Horse. The POJ may adjust speeds or distances in adverse weather conditions. Provision must be made for cooling conditions and equipment for horses after competing.
  - d. Stables must be safe, hygienic, comfortable, well ventilated and of sufficient size for the type and disposition of the Horse. Washing-down areas and water must always be available.
4. Every effort must be made to ensure that horses receive proper attention after they have competed and that they are treated humanely when their competition careers are over. This covers proper veterinary care, competition injuries, euthanasia and retirement. More specifically
  - a. Veterinary expertise must always be available at an Event. If a Horse is injured or exhausted during a Competition, the Driver must stop competing and a veterinary evaluation must be performed.
  - b. Wherever necessary, Horses should be collected by ambulance and transported to the nearest relevant treatment centre for further assessment and therapy. Injured Horses must be given full supportive treatment before being transported.
  - c. The incidence of injuries sustained in Competition should be monitored. Ground surface conditions, frequency of Competitions and any other risk factors should be examined carefully to indicate ways to minimise injuries.
  - d. If injuries are sufficiently severe a Horse may need to be euthanised on humane grounds by a veterinarian as soon as possible, with the sole aim of minimising suffering.
  - e. Horses must be treated sympathetically and humanely when they retire from Competition.
5. Any action or intent of doping and illicit use of medication constitutes a serious welfare issue and will not be tolerated. After any veterinary treatment, sufficient time must be allowed for full recovery before Competition.
6. The BEF and its members urge all involved with the sport to attain the highest levels of education in their areas of expertise.
7. A Horse may not compete if its sensory hairs have been clipped or shaven or in any other way removed unless individual sensory hairs have been removed by a veterinarian to prevent pain or discomfort for the Horse. Areas of hair that must be clipped, shaven or removed to allow veterinary treatment are exempt from this rule

## **Abuse of the horse**

1. Abuse of the Horse - Definition - Abuse of a horse means an action or omission that causes, or is likely to cause, pain or unnecessary discomfort to a horse including, but not limited to:
  - a. Pressing of exhausted horses,
  - b. excessive use of a driving aid,
  - c. Inappropriate use of a driving aid
  - d. Hitting the carriage or shouting excessively at the horse in an attempt to make it go faster
  - e. an unacceptably severe, badly fitting, broken or damaged bit,
  - f. badly fitting harness which might cause distress to the horse, or
  - g. damage to a carriage which might cause injury to the horse

## **Fitness to Compete**

### **2. Fitness and Competence**

Participation in competition must be restricted to fit horses and drivers of proven competence. Horses must be allowed suitable rest period between training and competitions; additional rest periods should be allowed following travelling.

### **3. Health Status**

No horse deemed unfit to compete may compete or continue to compete, veterinary advice must be sought whenever there is any doubt.

### **4. Doping and Medication**

Any action or intent of doping and illicit use of medication constitute a serious welfare issue and will not be tolerated. After any veterinary treatment, sufficient time must be allowed for full recovery before competition.

### **5. Surgical Procedures**

Any surgical procedures that threaten a competing horse's welfare or the safety of other horses and/or drivers must not be allowed.

### **6. Pregnant/recently foaled mares**

Mares must not compete after their fourth month of pregnancy or with foal at foot.

### **7. Misuse of aids**

Abuse of a horse using natural riding aids or artificial aids (e.g. whips, spurs, etc.) will not be tolerated.

8. A horse may not compete more than once at any event excepting Gateway where they may compete twice. (Maximum of 8 obstacles at any event)

## **Humane treatment of horses**

### **1. Veterinary treatment**

Veterinary expertise must always be available at an Event. If a horse is injured or exhausted during a competition, the athlete must stop competing and a veterinary evaluation must be performed.

### **2. Referral centres**

Wherever necessary, Horses should be collected by ambulance and transported to the nearest relevant treatment centre for further assessment and therapy. Injured horses must be given full supportive treatment before being transported.

### **3. Competition injuries**

The incidence of injuries sustained in competition should be monitored. Ground surface conditions, frequency of competitions and any other risk factors should be examined carefully to indicate ways to minimise injuries.

### **4. Euthanasia**

If injuries are sufficiently severe a horse may need to be euthanized on humane grounds by a veterinarian as soon as possible, with the sole aim of minimising suffering.

### **5. Retirement**

Horses must be treated sympathetically and humanely when they retire from competition.

## Education

The BEF and FEI urges all those involved in equestrian sport to attain the highest possible levels of education in areas of expertise relevant to the care and management of the competition horse.

This Code of Conduct for the Welfare of the Horse may be modified from time to time and the views of all are welcomed. Particular attention will be paid to new research findings and the FEI encourages further funding and support for welfare studies.

## BC CODE OF CONDUCT

### Conduct and Discipline

#### 1. Agreement to be bound by the Rules

Every member of British Carriagedriving has, by joining British Carriagedriving, agreed to be bound by the Memorandum and Articles of Association and all rules, regulations and by-laws made thereunder and has agreed that the decisions of the Council and other competent authorities of British Carriagedriving given in accordance therewith shall be final and binding upon them.

- 1.1. Copies of the Memorandum and Articles of Association, rules, regulations and by-laws passed from time to time can be obtained from the British Carriagedriving office.

#### 2. General Rules of Conduct

No member, nor any person for whom they are in law or under these Rules responsible, shall at or in relation to a Driving Trial or Show or at or in relation to any training, coaching or other kind of event organised by British Carriagedriving, or a club affiliated to British Carriagedriving:

- 2.1. commit any act or conduct themselves in a manner which is in the reasonable opinion of the British Carriagedriving Council:
  - 2.1.1. unsportsmanlike
  - 2.1.2. inconsiderate or discourteous
  - 2.1.3. prejudicial to the interests of British Carriagedriving
  - 2.1.4. detrimental to the reputation of British Carriagedriving
- 2.2. conduct themselves in a manner which is improper, abusive, offensive or violent toward any person or to the public in general or liable to bring British Carriagedriving and/or the sport of Horse Driving Trials into disrepute;
- 2.3. disobey or deliberately ignore any reasonable instruction given by the organiser of an event or by any Judge, Official or Safety Officer or do anything which is liable to disrupt the competition;
- 2.4. argue with or use abusive language or behave with incivility or contempt toward the organiser of an event or any Judge, Official, Safety Officer or volunteer.
- 2.5. publish any defamatory or malicious criticism of British Carriagedriving, its Council or an organiser of an event, Judge, Official or Safety Officer.
- 2.6. offer any bribe, payment or inducement to a Judge, Official or member of British Carriagedriving with a view to affecting the outcome of any entry to or outcome of a competition or selection for any team;
- 2.7. discriminate against any other person (whether a member of British Carriagedriving or a club affiliated to British Carriagedriving or not) on the grounds of their age, gender (including gender reassignment), sexual orientation, race, ethnic origin, nationality, parental, marital or civil partnership status, pregnancy or maternity, religious beliefs or of any disability.
- 2.8. contravene British Carriagedriving's Equality Policy or British Equestrian Safeguarding Policies which have been adopted by British Carriagedriving
- 2.9. use any drone or remote or radio controlled aircraft of any kind unless with the permission of the event organiser and the President of the Jury.

### 3. Driving Rules of Conduct

No member, nor any person for whom they are in law or under these Rules responsible, shall at any Driving Trial or Show or at a training or other event organised by British Carriagedriving or a club affiliated to British Carriagedriving:

- 3.1. drive recklessly or dangerously
- 3.2. misuse the driving aid (whip) or ill-treat any horse or pony
- 3.3. compete with a horse or pony which is lame, sick or exhausted
- 3.4. excessively press an exhausted horse or pony
- 3.5. allow a horse or pony for which they are responsible as owner and/or driver to compete under the influence of any forbidden substance. Such member shall be in breach of this rule if an analysis of a sample taken from the horse or pony shows the presence in its body fluids of any prohibited quantity of any substance which is either a forbidden substance or one of its metabolites or a substance which cannot be traced to normal and ordinary feeding and which by its nature is likely to affect the performance of that animal.
- 3.6. unreasonably refuse to allow a horse or pony which has or is about to compete in any competition to undergo any properly authorised test or examination if requested to do so by a duly authorised official of British Carriagedriving or of the Organising Committee.
- 3.7. conduct themselves in such a manner that they have or may have committed or have or may have been party or privy to any breach of the Memorandum and Articles of Association or of any rule, regulation or bylaw of British Carriagedriving. A member shall be in breach of this Rule in the event that any person who assists, represents or acts on behalf of or is in the employment of such member during the course of any Driving Trial or Show, conducts themselves in such a manner that were they a member of British Carriagedriving they would be in breach of any of these rules.
- 3.8. unreasonably fail or refuse to assist a duly authorised official of British Carriagedriving or of the Organising Committee in their investigations of complaints of misconduct or ill-discipline by any member.
- 3.9. make any statement either orally or in writing to any duly authorised official of British Carriagedriving or of the Organising Committee which they know or have reasonable cause to suspect is untrue or incomplete.

### 4. Discipline

- 4.1. The President of the Jury (or their appointee) in the absence of a designated disciplinary panel, may act as a "Disciplinary Steward" at the Driving Trial or Show for which they are appointed. If, in the reasonable opinion of the Disciplinary Steward, any member and/or driver has acted in breach of these rules whilst at a Driving Trial or Show, or the Disciplinary Steward shall receive a complaint in writing alleging such a breach, then the Disciplinary Steward shall convene a Committee of Inquiry as soon as reasonably practicable.
- 4.2. The Committee shall consist of any member of the Council present at that event, a member of the Organising Committee and shall be chaired by the Disciplinary Steward
- 4.3. No member of the Committee shall have been involved in the matters forming the basis of the complaint.
- 4.4. The Committee of Inquiry shall call for the member against whom the breach has been alleged ("the Member") to attend before it, together with any witnesses or any person whom the Committee of Inquiry feel in their reasonable discretion could assist it in its deliberations;
  - 4.4.1. Any unreasonable refusal to attend shall be treated as a breach of Rule 3.8 above;
- 4.5. The Committee of Inquiry shall provide the Member with a written statement of the substance of the complaint;
- 4.6. In the presence of the Member, any witness or other person called to assist the Committee of Inquiry shall be called to give their evidence or assistance;
  - 4.6.1. The Member and Committee shall be entitled to ask any such witness or person any reasonable questions relevant to the complaint;
- 4.7. Once the Committee of Inquiry has satisfied itself that it has heard all relevant evidence reasonably capable of being adduced, it shall invite the Member to put forward their own defence;
  - 4.7.1. The Member may present oral or written evidence and may call and examine witnesses, but shall not be entitled to legal representation;
- 4.8. Once the Committee of Inquiry has heard the Member's representations it shall ask the Member to withdraw, to enable it to conduct its deliberations;

- 4.9. As soon as is reasonably practicable the Committee of Inquiry will reconvene and call the Member before it and announce its decision;
- 4.10. The Committee of Inquiry can impose any of the following penalties:
  - 4.10.1. Dismiss the complaint;
  - 4.10.2. Take no action with regard to the complaint;
  - 4.10.3. Deliver a reprimand;
  - 4.10.4. Suspend the Member and/or horse(s) or pony(s) from taking any further part in the event;
  - 4.10.5. Disqualify the Member and/or horse(s) or pony(s) from any part of the event;
  - 4.10.6. If, in the opinion of the Committee of Inquiry, the Member has been guilty of a breach of the rules set out in this annex, report the matter to the Council and advise the Member that details of the complaint and evidence brought before it will be forwarded to the Council for further action.

## 5. The Council

- 5.1. The disciplinary procedure set out below will apply if:
  - 5.1.1. it appears to the Council that any person may, at any time, have been guilty of a breach of the rules or of the British Carriagedriving Equality Policy or British Equestrian Safeguarding Policies as adopted by British Carriagedriving;
  - 5.1.2. a report is received by the Council from an official;
  - 5.1.3. a complaint is received by the Council against a member of British Carriagedriving, or any person assisting a member, as a result of which the Council considers that any person (hereafter "the Member") may, at any time, have been guilty of a breach of the rules set out in this annex, or of the British Carriagedriving Equality Policy or British Equestrian Safeguarding Policies as adopted by British Carriagedriving
- 5.2. In the circumstances referred to above:-
  - 5.2.1. The Council shall appoint from its elected members no fewer than three persons who shall comprise the Disciplinary Committee.
  - 5.2.2. No member of the Disciplinary Committee shall have been involved in the matters forming the basis of the complaint;
  - 5.2.3. The Disciplinary Committee will appoint from its own number a Chairman.
  - 5.2.4. All decisions of the Disciplinary Committee shall be made by a simple majority of the members of it.
- 5.3. The Council shall circulate to the members of the Disciplinary Committee the substance of the allegations or of the complaint or, if from a Committee of Inquiry, the Report of the Disciplinary Steward:
  - 5.3.1. The Disciplinary Committee shall in its absolute discretion be entitled to make any enquiries it deems fit.
  - 5.3.2. If, as a result of making any such enquiries, evidence is obtained upon which the Disciplinary Committee intends to rely, the substance of that evidence will be communicated to the Member.
- 5.4. If, having considered the Report of the Disciplinary Steward and/or the complaint made to the Council, and conducted such enquiries as it thinks are appropriate, the members of the Disciplinary Committee are satisfied that there has been no breach of the rules set out in this annex or of the British Carriagedriving Equality Policy or British Equestrian Safeguarding Policies as adopted by British Carriagedriving then it shall notify (1) the Council, (2) the Disciplinary Steward and/or the person making the complaint (if any) and (3) the Member against whom the disciplinary procedure has been invoked, providing brief reasons for its decision.
- 5.5. If the members of the Disciplinary Committee are satisfied that the Member against whom the disciplinary procedure has been invoked may at any time, have been guilty of a breach of the rules set out in this annex or of the British Carriagedriving Equality Policy or British Equestrian Safeguarding Policies as adopted by British Carriagedriving then a Disciplinary Hearing will be arranged.
- 5.6. Not less than 21 days prior to the Disciplinary Hearing the Member shall be notified in writing of the date and venue for the meeting and of the substance of the allegations of the complaint, or in the case of a referral by a Committee of Inquiry, the Member shall receive a copy of the Report of the Disciplinary Steward.
- 5.7. The Member may appear in person to answer the allegations of breach and/or complaint and may present at the meeting oral or written evidence and may call and examine witnesses, but shall not be entitled to legal representation.

- 5.8. The Member may also submit written evidence and statements for consideration in their absence.
- 5.9. If the Member fails to appear at the Disciplinary Hearing the Disciplinary Committee shall be entitled to reach a decision and, if appropriate, impose a penalty in the absence of the Member.
- 5.10. The Disciplinary Committee shall dismiss the complaint and conclude the Disciplinary Procedure unless it is satisfied that the Member has been guilty of a breach of the rules or of the British Carriagedriving Equality Policy or of British Equestrian Safeguarding Policies as adopted by British Carriagedriving, in which case the Disciplinary Committee shall notify the Member of its decision in writing, giving brief reasons, and can impose any of the following penalties:
  - 5.10.1. Take no action with regard to the complaint
  - 5.10.2. Suspend the Member and/or horse(s) and pony(s) from taking part in any affiliated event to which these rules apply for a period not exceeding three months. The period of suspension to take effect from such date as the Disciplinary Committee shall decide, being a date not more than five months from the date of the Disciplinary Committee's decision
  - 5.10.3. Disqualify the Member and/or horse(s) or pony(s) from any part or all of the event
  - 5.10.4. Impose a fine of up to £100.
  - 5.10.5. If a fine is imposed under this rule the Member shall not participate in any affiliated event to which these rules apply until the fine has been paid in full.
  - 5.10.6. Suspend the Member from membership of British Carriagedriving
  - 5.10.7. Expel the Member from membership of British Carriagedriving
- 5.11. In the absence of manifest error, the findings of and penalties imposed by the Disciplinary Committee shall be final and binding on the Member and the person making the complaint.

## 6. Appeal

- 6.1. Any Member whose conduct has been referred to a Disciplinary Committee and who is dissatisfied with the Disciplinary Committee's decision may appeal to British Equestrian Appeal Committee subject to the British Equestrian terms of reference.

## 7. Promulgation

- 7.1. The Council may in its absolute discretion publish any disciplinary findings, ruling or direction concerning any person or matter in such manner as it thinks fit, whether in the public press or otherwise and every member of the Association shall be deemed to have consented thereto.

## 8. Equine Anti-Doping and Controlled Medication

- 8.1. It is forbidden for a driver to use, or to administer to any of his horses, or for any person to distribute to a driver, any forbidden substance.
- 8.2. Each person who becomes a member of British Carriagedriving agrees to be bound by the BEF Equine Anti-Doping and Controlled Medication Rules ("BEFAR") which are specifically incorporated by reference in, and form part of, the British Carriagedriving Rule Book. Copies of BEFAR can be found on the British Equestrian website at [www.bef.co.uk](http://www.bef.co.uk) and will be supplied to a member in paper format on request. The Equine Prohibited Substances List can be viewed at [www.bef.co.uk](http://www.bef.co.uk).

Accordingly, by becoming a member, such person shall be deemed to have agreed, amongst other things:

- 8.2.1. to be bound by, and to comply strictly with, BEFAR;
- 8.2.2. to submit to the authority of the BEF and/or of British Carriagedriving to apply, police and enforce BEFAR;
- 8.2.3. to provide all requested assistance to the BEF and British Carriagedriving (as applicable) in the application, policing and enforcement of BEFAR, including (without limitation) cooperating fully with any investigation, results management exercise, and/or proceedings being conducted pursuant to BEFAR in relation to any potential Anti-Doping or Controlled Medication Rule Violation(s);

**And except where the FEI has jurisdiction over the potential Anti-Doping or Controlled Medication Violation:**

- 8.2.4. to submit to the exclusive jurisdiction of any BEF First Instance Hearing Body convened under BEFAR to hear and determine charges and related issues arising under BEFAR;

- 8.2.5. to submit to the exclusive jurisdiction of any Sports Resolution UK Panel convened under BEFAR to hear and determine appeals made pursuant to BEFAR; and
- 8.2.6. not to bring any proceedings in any court or other forum that are inconsistent with the foregoing submission to the jurisdiction of the BEF First Instance Tribunal, and Sports Resolution UK.
- 8.3. Any person assisting or inciting others in the contravention of the forbidden substances regulations shall be considered as having committed an offence against the National Rules and may be subject to disciplinary action.

## FEI CODE OF CONDUCT

The FEI requires all those involved in international equestrian sport to adhere to the FEI Code of Conduct and to acknowledge and accept that at all times the welfare of the Horse must be paramount. Welfare of the horse must never be subordinated to competitive or commercial influences. The following points must be particularly adhered to:

### a) **Good horse management**

Stabling and feeding must be compatible with the best horse management practices. Clean and good quality hay, feed and water must always be available.

### b) **Training methods**

Horses must only undergo training that matches their physical capabilities and level of maturity for their respective disciplines. They must not be subjected to methods which are abusive or cause fear.

### c) **Farriery and tack**

Foot care and shoeing must be of a high standard. Tack must be designed and fitted to avoid the risk of pain or injury.

### d) **Transport**

During transportation, horses must be fully protected against injuries and other health risks. Vehicles must be safe, well ventilated, maintained to a high standard, disinfected regularly and driven by competent personnel. Competent handlers must always be available to manage the horses.

### e) **Transit**

All journeys must be planned carefully, and horses allowed regular rest periods with access to food and water in line with current FEI guidelines.

## OFFICIALS CODE OF ETHICS

### **1. Purpose**

Officials in British Carriagedriving exercise exceptional authority and responsibility. Their effectiveness depends not only on technical competence and knowledge of the rules, but also on fairness, integrity, discretion, and professionalism.

This Code of Conduct applies to all officials (including judges, stewards, technical delegates, course designers, and event organisers) at all times when officiating or attending competitions. It should be read in conjunction with the current British Carriagedriving Rule Book.

## **2. Principles of Conduct**

### **2.1 Impartiality & Fairness**

- Act without bias, favouritism, or prejudice.
- Disclose any interest or relationship that could give rise to a conflict of interest.
- Where there is doubt, it is always better to step aside rather than risk an actual or perceived conflict.

### **2.2 Competence & Integrity**

- Maintain up-to-date knowledge of the rules, tests, and technical standards.
- Attend required training, clinics, and refreshers.
- Act honestly, avoiding any misrepresentation of abilities, outcomes, or results.

### **2.3 Respect & Professionalism**

- Interact respectfully with drivers, fellow officials, grooms, volunteers, organisers, and spectators.
- Avoid offensive, abusive, or discriminatory behaviour.
- Maintain composure and good manners, even under pressure or in challenging circumstances.

### **2.4 Consistency & Transparency**

- Apply the rules equally to all drivers.
- Where required, be prepared to explain the reasoning behind decisions.
- Ensure results are checked and accurate before leaving an event.

### **2.5 Welfare of the Horse**

- The welfare of the horse is paramount and must never be compromised for competitive or other pressures.
- Intervene promptly if horse welfare is at risk, including stopping or disqualifying a driver if necessary.

### **2.6 Safety**

- Take all reasonable steps to ensure the safety of drivers, horses, officials, volunteers, equipment, and the venue.
- Follow and enforce all event safety procedures.
- Report or address hazards without delay.

### **2.7 Conflicts of Interest & Ethics**

- Do not excessively solicit invitations to officiate at events.
- Do not accept gifts, inducements, or any form of influence that could compromise neutrality.
- Avoid situations where impartiality could reasonably be questioned.

### **2.8 Confidentiality & Privacy**

- Respect the confidentiality of jury deliberations, protest or complaint processes, and any sensitive information.
- Share performance-related comments only with the driver concerned, your writer, or authorised individuals.

## 2.9 Compliance & Accountability

- Adhere to the rules and regulations of British Carriage Driving, and FEI where applicable.
- Cooperate fully with any official investigations or disciplinary procedures.
- Accept outcomes and sanctions when misconduct is proven.

## 3. Practical Expectations for Officials

- Reply promptly to invitations to officiate.
- Arrive at the event in good time and prepared.
- Inspect arenas, courses, and facilities to ensure compliance and safety.
- Keep to schedule wherever possible.
- Be courteous and clear with assistants (e.g., writers), explaining how marks and comments will be given.
- Do not allow drivers or their associates to sit in during judging or official deliberations.

## 4. Dress Code

- The standard dress code for officials at competitions is *smart casual*: neat, professional attire that is polished but relaxed.
- Hats (e.g., trilbys, panamas) are optional but can complement appearance.
- Clothing displaying advertising or commercial sponsorship is not permitted.

## 5. Decision-Making in Exceptional Circumstances

Not every eventuality can be covered by rules or this Code. In unforeseen or exceptional circumstances, it is the duty of the Ground Jury or designated officials to make decisions in a fair and sporting spirit.

## CODE OF CONDUCT FOR BC COACHES

Coaches should be aware that everyday decisions and choices have ethical implications

### Safety and welfare

Coaches should encourage high standards of Safety and Welfare for drivers, driver's support team, horses/ponies, spectators, other coaches, assistants, judges and officials.

Coaches should ensure adequate insurance cover is in place for all aspects of their coaching.

Coaches should ensure that the activities they direct or advocate are appropriate for the age, maturity, experience, stage of learning and ability of those taking part.

## **Competence**

Coaches should encourage good practice in all areas.

Coaches should confine themselves to practice in those areas to which they are recognised by their member body.

Coaches should ensure that they take part in CPD and maintain effectiveness as a coach.

Coaches should ensure safeguarding guidelines are adhered to and ensure their safeguarding is up to date.

Coaches should not necessarily be experts in all fields, but should know of, and be prepared to work with, other specialists where necessary.

Coaches should only coach to the level that they are qualified

Only qualified driving coaches may advertise themselves as an accredited coach and should stipulate the level of their qualification. A list of accredited driving coaches is available on the BC website.

## **Confidentiality**

Coaches should not disclose or use personal information unless an agreement has been reached with driver/participants and/or their parent/guardian. Information should be stored in a secure place and should not be shared without the appropriate permission. Such information is covered by the DPA.

## **Integrity**

Coaches should treat participants with respect, dignity and equality, within the context of the sport.

Coaches should not compromise a driver by advocating rule breaking, compromising safety or the welfare of the horse.

Coaches should instil good values, encourage respect for opponents and prepare drivers to respond to success and failure with dignity.

Coaches should develop a working relationship based on trust and respect.

Coaches should encourage drivers to advise all their accompanying personnel to adhere to all current BC rules and in particular those concerning their conduct and welfare to equines.

Any failure on the part of the coach to comply with the provisions of this code could bring the sport into disrepute.

## **SAFETY & SAFEGUARDING**

Properly secured hard hats must be worn by all people on the carriage or riding an equine at all times at an event. Hard hats must be to an appropriate standard see Annex 17.

## ARTICLE 901 CATEGORIES AND LEVELS

Classes:

All, or any, of the following classes may be held at the same event; classes may be amalgamated if Required:

|                                 |   |
|---------------------------------|---|
| Gateway Newcomers               |   |
| Gateway Allcomers               |   |
|                                 | Very Small Equines (VSE)                        |
|                                 | Small Equine (SE)                               |
| Pre-Novice Horse                | Pre-Novice Pony                                 |
| Novice Single Horse             | Novice Single Pony                              |
| Open Single Horse               | Open Single Pony                                |
| Advanced Single Horse           | Advanced Single Pony                            |
| Open Horse Pairs                | Open Pony Pairs                                 |
| Advanced Horse Pairs            | Advanced Pony Pairs                             |
| Horse Tandems                   | Pony Tandems                                    |
| Horse Fours                     | Pony Fours                                      |
| Drivers with Disabilities (DwD) | Young Drivers (Children, Junior & Young Driver) |

### ARTICLE 902 COMPETITIONS

At the conclusion of each competition, the drivers will be classified according to the penalties received in that competition.

In each competition, the winner is the driver with the least number of penalties. Scores will be calculated to two decimal places.

---

### ARTICLE 903 EVENTS

The Final Classification for individuals is determined by adding together the penalties received in each competition. The driver with the lowest number of penalties is the winner of the event.

Drivers who are Eliminated or Disqualified or who Retire or Withdraw in any one of the competitions cannot be included in the Final Classification. They will only be listed on the result sheet as: Eliminated (E), Disqualified (D), Retired (R) or Withdrawn (W).

---

### ARTICLE 904 EQUALITY OF SCORES

If there is an equality of scores on completion of the three competitions, the driver with the least number of penalties in the marathon will be classified above the others. If there is still an equality of points, the scores in dressage will be the deciding factor.

---

### ARTICLE 908 NAMES OF HORSES

Where possible, the names of the horses, including the spare horse, should appear on all score sheets and must be entered on the entry form.

---

### ARTICLE 910 OFFICIAL RESULTS

Results are “official” as soon as they have been signed by the President of the Ground Jury and published on the official scoreboard. The time at which results are signed and posted and become Official must be marked on all Official Results.

Drivers have 30 minutes from the time official results are published to submit any queries or challenge the scores. All concerns should be directed to the Technical Director (TD) or President of the Jury (POJ)

#### **Posting of Results**

Provisional results may be posted (online and/or at the event) at the discretion of the Scorer. Provisional Results which are posted must be clearly marked as being provisional and subject to approval by the President of the Jury.

---

### ARTICLE 911 PRINCIPLES

#### **Penalties**

The rules concerning the event and each competition must be strictly enforced by the Ground Jury. Drivers who fail to comply with these rules may incur Disqualification or Elimination, unless some other penalty is prescribed in the relevant Article.

### **Yellow Warning Card**

Where there is abuse of horses in any form, incorrect behaviour towards Event Officials or any other party connected with the Event, or non-compliance with the Driving Rules, the President of the Ground Jury and the Technical Delegate may deliver to the Person Responsible a Yellow Warning Card.

### **Disqualified (D)**

Drivers and horses may be disqualified for contravening the rules at any time during an event. A driver or horse who has been disqualified is prohibited from taking any further part in the event or winning any prize.

### **Eliminated (E)**

Drivers will be eliminated from a competition as a penalty for contravening certain rules during the competitions.

Drivers who are eliminated may compete in the subsequent competition(s) in the event.

### **Retired (R)**

Drivers, who, for any reason, do not wish to continue, may decide to retire during any of the competitions. If a driver retires in a competition he is allowed to compete in the subsequent competitions in the event.

### **Withdrawn (W)**

Drivers are deemed to have withdrawn if, for any reason, they fail to start in any of the competitions. Once withdrawn, drivers may not take any further part in the event with the turnout in question.

### **Lame or Unfit Horses**

If a horse is deemed to be lame or unfit by a member of the Ground Jury, then the horse must be disqualified and may not compete on any other competition at the event.

### **Placings and Prizes**

Drivers who Retire or are Eliminated from any competitions may not be placed in that competition or in the final classification.

Drivers may only receive a prize in competitions in which they have competed without Disqualification, Elimination or Retirement.

ARTICLE 9<sub>12</sub> MINIMUM AGE DRIVERS AND GROOMS

Drivers and grooms at events run under British Carriagedriving rules.

| Class  | Driver      | Groom    |
|--|-------------|----------|
| Horse Fours / Horse Pairs / Horse Tandems    | 18 years    | 14 years |
| Horse Pairs                                  | 16-17 years | 18 years |
| Horse Single and all Pony Classes            | 18 years    | 14 years |
| Horse Single and all Pony Classes            | 14-17 years | 18 years |
| Single Pony                                  | 12-14 years | 18 years |
| Gateway, SE & VSE, Young Driver– all classes | 6*-11 years | 21 years |
| Gateway, SE & VSE - multiples                | 12-13 years | 18 years |
| Drivers with Disabilities                    |             | 18 years |

### 1. Age

- 1.1. Age is determined from the beginning of the calendar year in which the driver/groom reaches the designated age.
- 1.2. Children: this is the category of drivers who may take part in FEI “Children” Competitions. Inclusion of drivers in this category takes place from the year they reach the age of 12 until the end of the year they reach the age of 14.
- 1.3. Junior: this is the category of drivers who may take part in FEI Competitions for Juniors from the year they reach the age of 14 until the end of the year they reach the age of 18.
- 1.4. U25: drivers may compete in the U25 category from the beginning of the calendar year in which they reach the age of 16 until the end of the calendar year in which they reach the age of 25.

\* Drivers must have passed their 6<sup>th</sup> birthday on the day of the event.

### 2. Grooms

- 2.1. All classes
  - 2.1.1. Drivers under the age of 18 years must be accompanied by a groom of appropriate age – see chart above.
  - 2.1.2. Drivers of 18 years and above must be accompanied by a groom(s) of 14 years or older.
  - 2.1.3. All grooms must physically capable of performing the role.

### 3. Drivers with Disabilities

- 3.1. The groom must be aged 18 or older,
- 3.2. All grooms should have knowledge of horse driving and associated risks and appropriate safety measures.
- 3.3. All grooms must have relevant driving experience. ,

Grooms must have confirmed that they accept the risks associated with back stepping for a Driver with Disabilities by confirming the statement as set out by the Drivers with Disabilities protocol. Grooms are only required to confirm this once and it will remain valid for any disabled turnout.

#### 4. Children Class

| Class       | Driver      |
|-------------|-------------|
| Single pony | 12-14 years |

Minimum grooms' ages depend on the driver age as defined above.

#### 5. Junior Classes

| Class            | Driver      |
|------------------|-------------|
| Horse Pairs      | 16-18 years |
| Horse Single     | 14-18 years |
| All Pony Classes | 14-18 years |

Minimum grooms' ages depend on the driver age as defined above.

#### 6. Under 25 (U25) Classes

| Class            | Driver      |
|------------------|-------------|
| Horse Fours      | 18-25       |
| Horse Pairs      | 16-25 years |
| Horse Single     | 16-25 years |
| All Pony Classes | 16-25 years |

Minimum grooms' ages depend on the driver age as defined above.

### ARTICLE 913 MEMBERSHIP

1. Drivers must be International, Full or Young members of British Carriagedriving appropriate to the level of event entered.
2. Drivers competing in Gateway Classes may compete as a member of a BC affiliated club. If a driver qualifies for and wishes to compete at the National championships they may do so, using Affiliated Club Memberships, for their first season only.
3. Making an entry for any affiliated Horse Driving Trials Event/Show constitutes acceptance of the British Carriagedriving rules.

### ARTICLE 915 HORS CONCOURS

1. Drivers may take part "Hors Concours" (HC) at National Events at the discretion of the Organising Committee providing the driver is eligible.
2. No HC entries will be accepted for the National Championships except if the class is a nominated event or a selection event for a World Championships.
3. 'Hors Concours' entries must be notified to the organiser prior to the start of the event. (See Article 948)
4. Hors Concours entries by the driver (if a second entry) must compete after the competitive turnout in all sections.
5. A start fee is payable.

The maximum number of horses that may be entered for an event must be in accordance with the schedule. Where this is not specified in the schedule, it shall be as follows:

| Class         | Number of horses |
|---------------|------------------|
| Singles       | 1                |
| Pairs/Tandems | 3                |
| Fours         | 5                |

#### 1. Class and Start Fees

- 1.1. Drivers can compete in any class for which they are eligible.
- 1.2. All drivers are due to pay a start fee on each entry (including Hors Concours) at all National and Affiliated Club Events (rates to be published annually by British Carriagedriving). Drivers entering a second turnout for just part of an Event will only be required to pay 50% of the start fee otherwise due, if for the full event a full start fee is due
- 1.3. Start fees will be payable on entries at international events in the United Kingdom, by all members entering through British Carriagedriving, when it is possible to qualify for the British Carriagedriving National Championships. Members entering through another National Federation will only be obliged to pay a start fee if they wish to be eligible for qualification for the British Carriagedriving National championships or for their result to count towards the British Carriagedriving Driver of the Year Points Leagues.
- 1.4. The entry fee and any late fee surcharge is to be determined by the Event Organiser.

#### 2. Withdrawals

3. Once an entry has been accepted and paid for, the driver will be assumed to be competing unless the organiser is notified as follows:
  - 3.1. Before the official closing date of entry, when a full refund of the entry fee will be given (less any fees incurred).
  - 3.2. By the official withdrawal date as stated in the individual event schedule. Refund of all or part of the entry fee at this stage is entirely at the discretion of the organiser.
4. Drivers withdrawing after the withdrawal date may forfeit their entry fees.
5. Start fees are not refundable once a driver has started any part of the competition.

#### 6. Penalties

7. If a driver fails to notify his intention to withdraw, without acceptable reason and proof, they will be penalised as follows:
  - 7.1. Fine of £50.
  - 7.2. They will not be allowed to compete at any other National Driving Trial unless the fine has been paid.
  - 7.3. Any fees paid in respect of such entries at another event will not be refunded.

**1. Dressage and cones**

- 1.1. The dress of drivers and grooms should conform to the style of the carriage and harness used.
- 1.2. Jackets or national dress, driving aprons, hats and suitable driving gloves are obligatory for drivers.
- 1.3. Grooms must wear jackets, hats and suitable gloves
- 1.4. The President of the Ground Jury may decide that:
  - 1.4.1. Jackets may be removed in excessively hot and humid weather
  - 1.4.2. Wet weather clothing may be worn and aprons not required.
- 1.5. During Dressage and Cones it is compulsory for all persons to wear properly fastened protective headgear.
- 1.6. Earphones and/or electronic communication devices may not be worn during Dressage and Cones Competitions. Drivers, Grooms or any other person may wear one earphone at any other time while on Carriage or mounted including on the marathon.
- 1.7. In Gateway classes, drivers and grooms may wear appropriate marathon clothing for all competitions.
- 1.8. Any driver or groom who is eliminated from any competition due to lack of mandated hard hat or body protector will be disqualified if they continue in that competition without suitable hard hat or body protector.

**2. Dress in Marathon and Combined Marathon**

- 2.1. Less formal dress is acceptable in the marathon for the driver and grooms. Shorts are not permitted.

**3. Dress for under 18s**

- 3.1. At all times, whilst on a carriage, all under 18s must wear a body protector and securely fastened protective headgear. Infringement will result in Elimination.

**4. Driving Aid for Dressage and Cones**

- 4.1. The driver must carry a driving aid.
- 4.2. The driving aid, if dropped, need not be replaced and the driver may finish without a driving aid. However, the groom may hand the driver a spare driving aid.
- 4.3. Drivers with Disabilities from nominated profiles may compete with the driving aid held / used by the groom but must have this noted with the organiser.

**5. Driving Aid for Marathon and Combined Marathon**

- 5.1. The driving aid can only be used by the driver. Use of a driving aid on the marathon and in the Combined Marathon is optional.
- 5.2. Drivers with Disabilities from nominated profiles may compete with the driving aid held / used by the groom but must have this noted with the organiser.

**6. Compensating Aids**

- 6.1. Drivers with Disabilities must apply to BC for permission to use Compensating aids or Other Reasonable Adjustments to assist them to compete in able-bodied competitions or other designated classes. The application form and protocol can be found on the BC website.

**7. Safety**

- 7.1. Properly secured hard hats must be worn by all people on the carriage or riding at all times at an event. Hard hats must be to an appropriate standard, see Annex 17.

**8. Access**

- 8.1. The dressage arena, obstacles and cones course may only be inspected on foot. No motor vehicles, electric vehicles or bicycles may be taken inside any part of an obstacle. Failure to comply will be penalised by the issue of a warning for the first infringement and a Yellow Warning Card for the second.
- 8.2. Drivers with disabilities must obtain dispensation from the organiser to be exempt from this rule and their vehicles clearly identified. Identification can be obtained from the British Carriagedriving office. Vehicles must be driven at walking pace in all competition areas.

## CHAPTER VI - HORSES

### ARTICLE 929 AGE OF HORSES

Horses must be 5 years old or over to compete in an outdoor marathon.

Horses must be 4 years old or over for all other parts of events.

Failure to comply with this article will result in the disqualification of the horse.

### ARTICLE 930 HEIGHT

Driving ponies must not exceed 148 cm without shoes, or 149 cm with shoes. Above these heights, they are classified as horses.

Very Small Equines (VSE) may not exceed 112cm. Small Equines may not exceed 127cm

There is no minimum height for ponies.

### ARTICLE 931 NUMBER OF HORSES

The correct number of horses stipulated for each class must be driven throughout each competition. Drivers may not remove one or more horses during a competition and continue with less than the number stipulated for their class.

A horse may only take part once in each competition except Gateway and dressage.

Failure to comply with any part of this article will result in elimination.

### ARTICLE 932 SPECIAL CONDITIONS

1. Mares are not allowed to compete after their fourth month of pregnancy or with a foal at foot. If it is subsequently confirmed that a mare competed under either of these conditions, the mare will be disqualified from all events to which these conditions apply and the case will be reported to British Carriagedriving.
2. A Horse may not compete if its sensory hairs have been clipped or shaven or in any other way removed unless individual sensory hairs have been removed by a veterinarian to prevent pain or discomfort for the Horse. Areas of hair that must be clipped, shaven or removed to allow veterinary treatment are exempt from this rule

### ARTICLE 933 WELFARE OF THE HORSE (ABUSE OF HORSES AND DOPING)

#### 1. Abuse of the Horse - Definition

- 1.1. Abuse of a horse means an action or omission that causes, or is likely to cause, pain or unnecessary discomfort to a horse including, but not limited to:
  - a) Pressing of exhausted horses
  - b) Excessive or inappropriate use of a driving aid
  - c) Hitting the carriage or shouting excessively at the horse in an attempt to make it go faster
  - d) An unacceptably severe, badly fitting, broken or damaged bit
  - e) Badly fitting harness which might cause distress to the horse
  - f) Damage to a carriage which might cause injury to the horse

#### 2. Wounds and Lacerations

- 2.1. Blood on horses may be an indication of abuse of the horse and must be investigated case by case by any member of the Ground Jury.
- 2.2. Such horses may be eliminated from the competition. In extreme cases where abuse is evident, further sanctions will be taken against the Driver, such as a Yellow Warning Card.

2.3. In minor cases of blood in the mouth, such as where a horse appears to have bitten its tongue or lip, or minor bleeding on limbs, the driver may be authorised to continue after investigation.

### **3. Reporting**

3.1. Stewards or any other Official, must report any instance of abuse of the horse to any member of the Ground Jury as soon as possible. Any instance of cruelty must be noted in the President of Jury's Report.

### **4. Penalty**

4.1. Acts deemed as Abuse of the Horse will result in the imposition by the Ground Jury of any or a combination of the following penalties:

4.1.1. Yellow Warning card

4.1.2. Fine

4.1.3. Elimination

4.1.4. Disqualification from the Event

## **ARTICLE 935 EXAMINATION AND INSPECTION OF HORSES**

### **1. In-Harness Horse Inspection**

1.1. A Ground Jury member must eliminate the driver if their horse is considered to be lame, injured or obviously exhausted and unfit to continue the competition and the driver may not continue on the marathon.

### **2. In-Harness Examination**

2.1. An examination may take place at the finish of Section B of the marathon. This is to be conducted by a member of the Ground Jury. Any concerns to be notified to the event veterinarian in the case of any equine needing treatment.

### **3. Removing a Horse from Competition**

3.1. Each member of the Ground Jury has the right and duty to eliminate any horse at any time which is evidently lame, injured or unfit to continue. No appeal may be made against a decision taken under the terms of this article.

3.2. The driver may retire at any time.

### **4. Medication Control of Horses**

4.1. It is forbidden to use, or to administer to any horse, or for any person to distribute, any forbidden substance.

4.2. Each person who becomes a member of British Carriagedriving agrees to be bound by the BEF Equine Anti-Doping and Controlled Medication Rules ("BEFAR") which are specifically incorporated by reference in, and form part of, the British Carriagedriving Rule Book. Full details can be found on the BC website.

4.3. Under the BEFAR rules, any horse participating in or registered for affiliated competition may be tested at any time, both in and out of competition.

### **5. National Passports**

5.1. All horses and ponies must have a recognised, statutory passport and unique identification number (UELN) in compliance with Government regulations.

5.2. Full details about vaccinations are available on the BC website.

ARTICLE 937 WEIGHTS AND DIMENSIONS

**1. General**

- 1.1. If the carriage has no brakes, breeching is compulsory for all classes when driving at any time at an event. Failure to comply will result in elimination.
- 1.2. Breeching is compulsory when driving a single horse or pony at the event, whether in competition or in training. No part of a carriage may be wider than the outside track width, with the exception of hub caps, mud guards and the splinter bar for carriages used in Dressage and Cones.
- 1.3. The track width of all carriages is measured at ground level on the widest part of the rear wheels.
- 1.4. Drivers whose carriages do not conform to the required weights or measurements will be eliminated from the relevant competition.

**2. Carriages for Drivers with Disabilities Classes**

- 2.1. **Drivers with Disabilities** Carriages suitable for the disabled driver must be used. For singles these may be 2 or 4-wheeled.
- 2.2. **The Organising Committee** or Technical Delegate may refuse the use of a carriage, but must give the reason for the refusal.

**3. Carriages for VSE classes:**

- Singles/tandems: 2 or 4 wheeler
- Pairs/Teams: 4 wheeler

**4. Dressage and Cones Carriages**

Carriages used for dressage and cones must comply with the following:

| Class                  | Wheels | Grooms  | Min. Width For Cones |
|------------------------|--------|---|----------------------|
| Horse Four             | 4      | 2 behind  | 158cm                |
| Pony Four              | 4      | 2 behind  | 138cm                |
| Horse Pair             | 4      | 1 behind  | 148cm                |
| Pony Pair              | 4      | 1 behind  | 138cm                |
| Horse Single/Tandem    | 2 or 4 | 1 behind or beside  | 138cm                |
| Pony Single/Tandem     | 2 or 4 | 1 behind or beside  | 138cm                |
| SE Single/Tandem       | 2 or 4 | 1 behind or beside  | 125cm                |
| VSE Single/Tandem      | 2      | 1 behind or beside or<br>1 in close attendance                  | 125cm                |
| VSE, Small Equine Pair | 4      | 1 behind  | 125cm                |
| VSE, Small Equine Four | 4      | 2 behind or, VSE only, 1<br>behind and 1 in close<br>attendance | 125cm                |

- 4.1. Drivers may use a marathon carriage for cones provided it meets the requirements above. For dressage, axles do not need to be extended. 3 phase vehicles can be driven in dressage at marathon width. No more than 2 carriages may be used at a Driving Event.
- 4.2. Artificial extensions to increase the measured width of a carriage are not permitted in cones.
- 4.3. All carriages must be measured as soon as the driver has left the competition arena after cones.

**5. Very Small Equine (VSE) classes:**

5.1. For minimum driver and groom ages see Article 912

**5.2. For 2 wheeled Carriages**

5.2.1. On the marathon grooms may travel near the driver on foot (or bike or quad if allowed by organiser).

5.2.2. The groom may stand on the backstep in dressage and cones.

5.3. Groom(s) who are not on the carriage must be in close attendance at all times throughout all phases (including the marathon section) being able to render assistance if required.

**5.4. For 4 wheeled Carriages**

5.4.1. For singles, pairs and tandems, the groom must be on the back step of the carriage

5.4.2. For a team (four in hand). There must be 2 grooms in attendance. One groom can be on foot in close attendance being able to render assistance if required, the other groom must be on the carriage

5.4.3. Minimum one groom to be on carriage in all phases.

5.5. Grooms in attendance but not on the carriage must wear securely fastened headgear (Annex 17) but a body protector is optional though recommended.

**6. Marathon Carriages and carriages for the Combined Marathon**

6.1. must comply with the following

| Class                   | Wheels   | Min. weight | Grooms         | Min. width |
|-------------------------|--|-------------|----------------|------------|
| Horse Four              | 4  | 600kg       | 2 behind       | 125cm      |
| Pony Four               | 4  | 300kg       | 2 behind       | 125cm      |
| Horse Pair              | 4  | 350kg       | 1 behind       | 125cm      |
| Pony Pair               | 4  | 225kg       | 1 behind       | 125cm      |
| Horse Single/Tandem     | 4  | 150kg       | 1 behind       | 125cm      |
| Pony Single/Tandem      | 4  | 90kg        | 1 behind       | 125cm      |
| Small Equine (SE)       | 2 or 4   | unspecified | See Art. 937.5 | 125cm      |
| Very Small Equine (VSE) | 2 or 4   | unspecified | See Art 937.5  | 125cm      |
| Gateway                 | Depending on size of horse – follow above weights and grooms |             |                | 125cm      |

6.2. In marathon, all carriages may be measured before the start of section A and the same carriage must be used for all sections.

6.3. The President of the Ground Jury will decide whether all, or a random selection of, carriages will be weighed after the marathon.

**ARTICLE 938 EQUIPMENT**

Lamps or reflectors are not compulsory in any phase.

**ARTICLE 939 TYRES**

Solid, pneumatic or air-filled tyres are permitted.

## 1. Equipment

### 1.1. Harness

1.1.1. The distance between the horse/pony and carriage must not be less than 50cm at all times, fender rolls 40cm.

### 1.2. Dressage Carriage

1.2.1. Horses (Four-in-Hand wheelers or a pair of Horses): the distance between the traces must be minimum 55 cm (Ponies: minimum 45 cm).

1.2.2. Traces must not cross each other. For pairs and fours, swingle trees may not cross the centre line of the carriage.

### 1.3. Marathon Carriage and Carriage for Combined Marathon

1.3.1. Horses (Four-in-Hand wheelers or a pair of Horses): the distance between the traces must be minimum 55 cm (Ponies: minimum 45 cm).

1.3.2. Traces must not cross each other.

### 1.4. Length of individual pole chains or pole straps

1.4.1. The length must be suitable for the size of the turnout.

### 1.5. Horse yoke or T-bar

1.5.1. The total width including the complete quick releases must be minimum of 60cm. When the measurement is taken from the centre of the pole head, to include the complete quick releases, it must be a minimum of 30cm.

1.5.2. Yokes or T-bars must not be positioned behind any part of the shoulder.

1.5.3. Pole and the pole straps must be of sufficient length to allow free movement of the horses.

1.5.4. For Horse Four-in-Hand leaders, the complete lead bar must measure at least 1m and the distance between the traces must measure at least 45 cm.

1.5.5. For Pony Four-in-hand leaders, the complete lead bars must measure at least 85cm and the distance between the traces must measure at least 35 cm.

1.5.6. Yoke width or pole straps must be of sufficient length to allow the free movement of the horses.

1.5.7. It is not necessary to use the same harness for dressage and cones, but in both competitions it must be safe, clean and uniform in appearance and in a style appropriate to the turnout.

1.5.8. The horses must be correctly and fully harnessed to the carriage, including the reins.

1.5.9. Failure to comply with this paragraph will result in a verbal warning or Yellow Warning Card, given by the Ground Jury. Subsequent offences at the same event will be penalised with a second Yellow Warning Card or Elimination.

1.5.10. At an event at all times, whenever a single horse is harnessed to a carriage, breeching is compulsory. Failure to comply results in Elimination.

1.5.11. Where forbidden equipment is used or a severe incidence on the welfare of the horse is ascertained, the penalty will be Elimination or Disqualification

## 2. Bandages and Brushing Boots

2.1. Bandages and brushing boots are not permitted in Dressage. Failure to comply will result in 10 penalty points.

2.2. If a penalty is applied under 940.2.1, the bandages or brushing boots must be removed immediately after leaving the arena and the horse(s) inspected by a steward who will report his findings to the President of the Ground Jury.

2.3. Hoof boots are allowed.

## 3. Nosebands, ancillary equipment and blinkers

3.1. Any nosebands, attachments or ancillary equipment which impede or are likely to impede the free intake of air into the nostrils of the horse are not permitted.

3.2. Blinkers, if used, and ancillary equipment must not impede forward vision or be so close to the eyes as to irritate them.

#### **4. Connecting straps**

4.1. Connecting straps between neck or breast collars may be used in all Four-in-Hand competitions. The leaders may not be attached to each other in any other way (except by the reins).

#### **5. Auxiliary reins**

5.1. Auxiliary reins (including any type of check reins) are not permitted when in harness.

5.2. Drivers with Disabilities: driving with a second set of reins or divided reins is not allowed.

5.3. A young driver under 12 years may be required to have a groom with a second set of reins. This groom must sit beside the driver.

#### **6. Tails**

6.1. Tails may not be tied or attached to any part of the harness or carriage, with the exception of a recognised tail guard. No other ancillary device restricting the free movement of the horse's tail is permitted.

#### **7. Leverage Devices**

7.1. All rings, terrets and/or other devices which have an extreme leverage effect on the reins or bits are forbidden at any time at events.

#### **8. Bits**

8.1. Bits do not need to be identical.

8.2. No bitless bridles or hackamores (even combined with any kind of bits) are permitted when the horse is harnessed to a carriage.

8.3. All bits must be correctly fitted, not broken or damaged, to avoid any risk of pain or injury.

8.4. Bits should be regularly checked for wear or damage.

8.5. Only one sort of bit lifter per horse may be used at a time.

#### **9. Tongues**

9.1. Tongue guards are only permitted if used correctly. Separate items must not be incorporated around the bit which may cause welfare concerns.

#### **10. Impaired Vision**

10.1. No attachment or ancillary harness may be positioned between the wheelers and the leaders in such a way as to impair the vision of either of the wheelers.

#### **11. Application or use of devices, substances or implements**

11.1. An attachment to the pole, traces or shafts, or application or use of any substance, device, or implement which may cause irritation or discomfort to the horse, is forbidden.

11.2. Ear hoods and plugs are permitted. Ear hoods may not be attached to the noseband and must allow free movement of the ears of the horse.

#### **12. Shoes**

12.1. Any conventional type of shoe is permitted. Double shoes or additional weight (lead) are not allowed anywhere at an event.

12.2. Hoof boots are allowed.

#### **13. Training Areas**

13.1. Lunging cavessons are permitted when lunging. Working long reins and double rein lunging are allowed as long as the rein is directly connected to the bit without any leverage device.

13.2. The lunge line must be attached to either a lunging cavesson or a Riding/Driving bridle/bridoon. Lunging with lunge line attached to the bottom slot is not allowed.

13.3. When riding, spurs must be of smooth material (metal or plastic). If there is a shank it must not be more than four centimetres long (the overall shank must be measured from the boot to the end of the spur) and must point only towards the rear

13.4. A whip no longer than 120 centimetres including lash is allowed when riding on the flat during training. A whip cannot be replaced by any other object.

13.5. When riding during training, side reins and martingales are allowed. Draw reins are forbidden.

#### **14. Penalties**

14.1. Contravention of paragraphs 3 to 10, 11.1, or 12 in this Article in competition will incur elimination of the driver. Contravention of paragraph 11.2 will result in a Yellow Warning Card unless the Ground Jury concludes that the contravention has affected the welfare of the horse or horses involved, in which case contravention will incur elimination.

14.2. Contravention of any paragraph in this Article at any other time at an event, with the exception of Article 940.2.1, will result in a Yellow Warning Card. A second offence at the same event will result in a higher penalty up to and including disqualification at the discretion of the Ground Jury.

### **ARTICLE 941 ADVERTISING ON CARRIAGES, HARNESS AND CLOTHING**

#### **1. Dressage and Cones**

1.1. The name of the harness manufacturer may appear once on each harness on a label no wider than the strap on which it appears and not longer than 10 cm.

1.2. The sponsor's name or "logo", or the driver's "association", may appear on each side of the carriage within a surface area no greater than 400 sq. cm.

1.3. The name of the carriage manufacturer may appear on a carriage on a label of not more than 50 sq. cm. Identification of clothing manufacturers may appear only once per item on a surface area not exceeding 3 sq. cm.

1.4. Whilst present in the competition arena, the name and/or logo of the individual's sponsor(s) and team sponsor(s) may appear on the surface area not exceeding 80 sq. cm and only once on jackets or top garments at the height of the breast pockets of drivers.

1.5. The name and/or logo of the individual's sponsor(s) and team sponsor(s) may appear on a surface area not exceeding 16 sq.cm on both sides of the driver's shirt collar.

#### **2. Marathon and Combined Marathon**

2.1. Advertising is allowed on carriages and all clothing. The name of the harness manufacturer may appear once on each harness on a label no wider than the strap on which it appears and no longer than 10cms

#### **3. Penalties**

3.1. Contravening any of the rules on advertising will result in a Yellow Warning Card issued by the President of the Ground Jury or the Technical Delegate.

3.2. The Technical Delegate may arrange random checks to ensure drivers comply with these rules.

### **ARTICLE 942 SAFETY**

1. At an event, whenever the horse(s) are fully harnessed or being harnessed to a carriage, groom(s) must at all times be in attendance and able to render assistance if needed. Whenever horses are driven, a groom (in the case of a single or pair) or two grooms (in the case of a four in hand) must be on the carriage or, where specified, in close attendance at all times.

2. Contravening the safety rules will result in a Yellow Warning Card being issued by the Ground Jury. Subsequent offences at the same event will be penalised by a second Yellow Warning Card, or penalty up to elimination, at the discretion of the Ground Jury.

3. The driver may only dismount from the carriage when grooms are at the horses' heads or the reins are given to another responsible person on the carriage. The carriage must be at a halt.

4. No horse may be led from a moving carriage unless there is an extra person on the carriage whose sole responsibility is the horse being led.

5. Medical Information - Drivers must provide a Contact Person or Next of Kin, to ensure that vital information is available to the Event Secretariat / first aid / or medical personnel, in case of an emergency. Ideally this person should not be their groom.

6. Drones may be only be used with prior written permission from the event organiser.
7. During the competition no person under the age of 14 may be on the carriage unless as a driver competitor.
8. Young drivers under the age of 16 must have a groom (age as per rule 912) on the carriage with them at all times – exception VSE.
9. Juniors who are passengers on carriages at events must wear a hard hat and body protector. Parents or Guardians take the absolute responsibility of risk for any juniors travelling on carriages. Another competent adult, as well as the driver, should also be present if the junior is under the age of 6 years, ideally on the carriage or on foot alongside the carriage. No babies can be carried on carriages.
10. Novice, Very Small Equine, Small Equines, Children, Juniors, Young Drivers, Drivers with Disabilities, Pre-Novice and Gateway classes must present their turnout for a safety check during the warm up for dressage and prior to commencing the marathon, also prior to cones in three day competitions or when the cones timetable involves unharnessing after the previous competition. This will be carried out by a member of the Ground Jury or a suitably experienced individual. The penalty for not presenting themselves is Elimination.
11. A securely fastened hard hat must be worn at all times by anyone riding on either a horse or carriage at an event. This includes drivers, backsteppers and passengers. See Annex 17 for details.
12. At all times, whilst on a carriage, all under 18s must wear a body protector in addition to their securely fastened protective headgear.
13. Drivers and grooms/backsteppers must wear securely fastened protective headgear and a suitable body protector while on the marathon with a recommendation that a level 3 body protector is worn.

### ARTICLE 943 PARTICIPATION

#### 1. Method of Driving

- 1.1. Drivers may use any safe method or style of driving.

#### 2. The Drivers and Grooms

- 2.1. All drivers attending British Carriage driving training events or competitions must have third party liability insurance for timed events.
- 2.2. Each driver must drive the same horse(s) in all the competitions, except where a substitution was decided in compliance with the rules. See Article 946.
- 2.3. Depending on the schedule a driver can compete twice or may also act as groom once.
- 2.4. Groom(s) may participate twice in all competitions at the discretion of the organiser.
- 2.5. Nobody can go round the marathon more than twice, whether as driver or groom or both, unless the organiser grants an exception.
- 2.6. During the 60 minute period immediately prior to each driver's scheduled start time for each competition only the driver may drive the turnout. Contravention of this rule will result in Elimination. The groom may walk the turnout if necessary for safety reasons. The driver is the only person allowed to handle the reins, use the driving aid and brake throughout each competition. Each contravention of this rule, even if to prevent an accident, will result in 20 penalties. However, a groom may handle the reins and brake without penalty in all competitions provided the carriage remains stationary.
  - 2.6.1. Para Driving Drivers from nominated profiles may compete with the whip held / used by the groom, the brake operated by the groom, and the groom holding the finger loop but must have this noted on the Master list following classification evaluation.
- 2.7. No person apart from a Driver with Disabilities / Para Driver may be tied to the carriage in any way during the competitions. A driver may be secured by rope, webbing or belt, provided one end is held by a Groom and not wrapped or fastened to the carriage in any way. Failure to comply will result in Elimination.
  - 2.7.1. Drivers with Disabilities / Para Drivers may be secured to their carriage by a lap belt or an approved harness provided it incorporates a quick release mechanism which (in the opinion of the driver) is suitable, taking into account the risks inherent in Horse Driving Trials and the characteristics of their turnout including size, shape and experience. Any event official can at any time request drivers or their grooms to demonstrate the quick release mechanism of any belt or harness worn.
- 2.8. In Dressage (as part of the test) and Cones, drivers will be required to salute the Jury unless time or layout of the course prevents it.
- 2.9. Passengers may not ride on a vehicle during any phase of the competition.
- 2.10. Each time a driver dismounts during any competition they will incur 20 penalties.
- 2.11. Drivers will incur penalties each time one or both grooms dismount
- 2.12. In the event of a potential head Injury an assessment (HIA) of the affected party must be made. There will be A 10 minute hold-up of the driver on course for an HIA. This holdup will take place without penalty other than any incurred during the initial incident.
- 2.13. No substitution of grooms is allowed during a competition.

### ARTICLE 944 IDENTIFICATION NUMBER

#### 1. Driver

Drivers will be allocated an event number per turnout and will retain that number throughout the event.

The number must be displayed on any carriage used during the dressage and cones competitions.

For easy identification drivers will be provided with marathon numbers by the Organisers to print at home. It is recommended that grooms wear these numbers both on their front and on their back during the Marathon and Combined

Marathon. If this recommendation is not followed, the driver must ensure that the marathon numbers provided are clearly displayed on each side of their carriage, and that they remain visible throughout the competition, particularly in wet or dirty conditions.

## 2. Penalties

Failure to display the event numbers of drivers will incur a warning for the first occurrence. A repeated offence will incur a Yellow Warning Card issued by the President of Jury or the Technical Delegate.

## ARTICLE 945 OUTSIDE ASSISTANCE

### 1. Definition

Any physical intervention by a third party not riding on the carriage, whether solicited or not, with the object of facilitating the task of the driver or helping the driver's horse(s), is considered to be outside assistance.

### 2. Prohibited outside assistance

#### 2.1. Dressage and Cones

2.1.1. Any driver who has received outside assistance may be eliminated by the Ground Jury.

2.1.2. In dressage, grooms must remain in their proper positions between entering and leaving the arena. Grooms must be seated for all classes except Gateway, VSE, Pre-Novice and Small Equine where they may stand. Grooms are not permitted to handle the reins or the driving aid (will incur 20 penalties). For dressage, speaking or indicating the course to the driver is not permitted (will incur elimination) except in Gateway and Pre-Novice classes. However the groom may handle the reins or the driving aid without penalty provided the carriage remains stationary.

2.1.3. **Exception:** If the bell has been rung in dressage and the driver has failed to hear the bell, the groom may advise the driver that the bell has been rung.

2.1.4. Drivers and grooms may not use any form of electronic communication equipment during dressage and cones, contravention will incur elimination.

2.1.5. Drivers with Disabilities / Para Drivers from nominated profiles may compete with the driving aid held / used by the groom and/or the groom holding the finger loop but must have this noted on Driver approval certificate and must present this to the organisers before the start of the event.

2.1.6. Grooms of Drivers with Disabilities must sit so that they can help in case of need. The Event Organiser or Technical Delegate has the right to disapprove the position of the groom on the vehicle.

#### 2.2. Marathon and Combined Marathon

2.2.1. Obstacle Observers, Ground Observers, Timekeepers or any other Officials may not give directions, advice or information to the driver, while the driver is on the course in the marathon in order to assist them.

2.2.2. Any driver who has received physical outside assistance by a third party not riding on the carriage will be eliminated by the Ground Jury, with the exception of the VSE class where there may be an on-foot groom in close attendance.

### 3. Permitted Assistance

3.1. The following are considered to be permitted outside assistance:

3.1.1. Assistance during the halt and in neutral zones between sections.

3.1.2. Assistance to avoid accidents.

3.1.3. Assistance to horses as a result of an accident inside an obstacle, providing the grooms are dismounted.

3.2. Assistance by the groom whereby a horse is led through an obstacle by a leadrope, or any part of the bridle or reins while harnessed to the carriage in either marathon or cones will incur 20 penalties for the assistance in addition to the penalties for dismounting.

## ARTICLE 948 STARTING ORDER

**1. Three Day Events with cones on day three**

- 1.1. Starting order for Dressage will be determined by the organiser.
- 1.2. Starting order for Marathon will be determined by the organiser.
- 1.3. Starting order for Cones

The drivers will go in reverse order of the results in dressage and marathon, so that the driver with the most penalty points from driven dressage and marathon will go first and the driver with the fewest penalties goes last, unless a driver is competing twice and has one or more entries in a selection class.

In the event of equal dressage and marathon penalties, the result of the marathon decides.

The starting order will be:

- a. Retired drivers, followed by
  - b. Eliminated drivers, followed by
  - c. Drivers competing twice with their turnout with the lower penalty score, followed by
  - d. The remaining drivers, commencing with the one with the highest number of penalties after dressage and marathon, so that the driver with the least number of penalties achieved without retirement or elimination will start last.
- 2. Two Day Events, three day events with marathon on day 3 and events including Combined Marathon**
- 2.1. The starting order for all three competitions will be determined by the organiser.
- 3. Selection classes and Hors Concours entries**
- 3.1. For classes used as selection classes the following will apply wherever possible for marathon and cones. The best placed turnout, or the one eligible for selection where the turnouts are in different classes, should go first unless granted an exception by the President of the Jury.
  - 3.2. If a driver has more than one entry and one is Hors Concours, then the HC turnout should be driven after the one entered in the competition unless granted an exception by the President of the Jury.

## CHAPTER XI – DRIVEN DRESSAGE

### ARTICLE 949 GENERAL

#### 1. **The Objective of Dressage**

The objective of the Driven Dressage Test is to judge the freedom, regularity of paces, harmony, impulsion, suppleness, lightness, ease of movement and correct bending of the horses on the move. Drivers will also be judged on style, accuracy, and general control of their horses, and also on their dress, condition of their harness and carriage and the presentation of their whole turnout.

#### 2. **Safety Check**

See 942.10

### ARTICLE 950 THE ARENA

The standard driven dressage arena for all classes is 80m x 40m and laid out in accordance with the diagram (Annex1). A smaller arena from 40 x 20m upward may be used for Gateway classes and a 100m x 40m arena may be used for Horse Fours, if stated in the schedule.

There should be clear demarcations to prevent anyone from getting closer than 5m to the edge of the arena.

### ARTICLE 951 DRIVEN DRESSAGE TESTS

Details of approved British Carriagedriving Driven Dressage Tests are shown on the British Carriagedriving website. The schedules for all events must state clearly which of these tests is to be used.

### ARTICLE 952 CONDITIONS

#### 1. **Entering the Arena**

A driver who enters the arena before the starting signal or who fails to enter the arena within 90 seconds of the starting signal may be eliminated at the discretion of the President of the Ground Jury.

#### 2. **Memory**

The British Carriagedriving Driven Dressage Test must be driven from memory. Speaking or indication given by a groom will incur Elimination, except for Gateway and Pre-Novice classes.

#### 3. **Lameness**

- 3.1. If the President of the Ground Jury observes a case of marked lameness, they must disqualify the horse and eliminate the driver. There can be no appeal against this decision.
- 3.2. In doubtful cases, after the driver has finished their test, the President of the Jury may have the horse checked immediately by the Veterinarian outside the arena. The horse will be checked while harnessed to the carriage. If the Veterinarian confirms the lameness, the horse must be disqualified and the driver Eliminated.
- 3.3. In competitions where additional dressage arenas are being used, the duty of the President of the Ground Jury as indicated above shall fall under the responsibility of the Judge at C of the applicable arena.

### ARTICLE 953 JUDGING

#### 1. **Positions of Judges**

When there are 3 judges officiating, they sit at C plus 2 of B,E,V or P.

When there are 2 judges officiating, they sit at C and B, E or V.

The positions may be changed in case of extreme weather conditions.

The President of the Ground Jury will decide the positions

## 2. **Allocation of marks**

The judges will allocate their marks individually. There will be no consultation among judges once the driver has started the test. Only the judge at C may give penalties for incomplete presentation or incidents.

## 3. **Multiple Turnouts**

Pairs, Tandems and Four-in-Hands will be judged as a whole and not as individual horses.

## 4. **Pace**

The definition of paces - movements will apply to all types and breeds of horses.

## 5. **Start and Finish**

The test starts as the driver enters the arena at A and finishes with the final salute unless otherwise stated. Tests are not timed. The driver should leave the arena at a trot.

# ARTICLE 954 MOVEMENTS AND THEIR DESCRIPTIONS

## 1. **Halt**

The horse must stand square, straight and motionless, remaining on the bit.

## 2. **Walk**

The horse walks energetically with a regular four beat movement, remaining in a light contact. The horse is supple with even and determined strides with the hind feet touching the ground in front of the footprints of the fore feet and stretching forwards and downwards.

## 3. **Free Walk**

Same definition as for the Walk, but in addition, gaining ground as much as possible, clearly lengthening the frame and stretching forwards and downwards.

## 4. **Extended Walk**

The Horse covers as much ground as possible, without haste and without losing the regularity of the steps. The hind feet touch the ground clearly in front of the hoof prints of the fore feet. The driver allows the horse to stretch out the head and neck (forwards and downwards) without losing contact with the mouth and control of the poll. The nose must be clearly in front to the vertical.

## 5. **Working Trot**

A forward, active regular trot, with the horse on the bit, carrying himself in balance and rhythm with even, elastic steps, good hock action and clear impulsion. The steps of the hind feet must at least be touching the ground in the footprints of the fore feet.

## 6. **Collected Trot**

The horse remains on the bit and moves energetically forward with a greater degree of engagement, leading to an increased flexion of the hocks and fetlock joints and raising up with the forehand, thus allowing for more mobility and elevation of the strides. The neck will be raised and more arched with the poll the highest part. The nose should not be behind the vertical or the neck restricted. The hind legs should take more weight, and cadence should be visible.

## 7. **Extended Trot**

7.1. The horse lengthens his stride to cover as much ground as possible as a result of greater impulsion from the hindquarters. The driver allows the horse, remaining "on the bit" without leaning on it, to lengthen its frame to gain ground, with the nose slightly in front of the vertical. The hind feet must clearly over track the prints made by the fore feet.

7.2. The horse must remain in balance while maintaining the same rhythm with strides of equal size. Hurried strides are not asked for and constitute a severe fault.

## 8. **Medium Trot**

Between the defined Working Trot and Extended Trot. The horse lengthens his stride to cover less ground than asked for in the Extended Trot but more ground than asked for in the Working Trot as a result of greater impulsion from the hindquarters. The driver allows the horse, remaining 'on the bit' without leaning on it, to lengthen the frame to gain ground, with the nose slightly in front of the vertical. The hind feet should over track the footprints made by the fore feet. The horse must remain in balance while maintaining the same rhythm with strides of equal size. Hurried strides are not asked for and constitute a severe fault.

#### 9. Working Canter

- 9.1. A forward, active pace with regular strides of three-time beat. The horse, showing good balance, remains on the bit without leaning on the hand, and goes forward with light cadenced strides and good hock action.
- 9.2. A Canter to the right, for instance, will have the following sequence of footfalls: left hind, left diagonal (simultaneously left fore and right hind), right fore, followed by a moment of suspension with all four feet off the ground before the next stride begins.
- 9.3. The quality of the canter is judged by the general impression, and the regularity and lightness of the three-beat pace in a clear uphill tendency. The horse must be on the bit and well engaged in the hindquarters with good hock action, and must have the ability to maintain his rhythm and natural balance throughout the movement and the transitions. The horse must remain straight on straight lines and correctly bent on curved lines.

#### 10. Collected Canter

Horse's strides are shorter than in working canter, the hocks maintain a clear impulsion and the hind legs take more weight; the point of gravity is moving backwards and the neck and poll coming up more with the nose always a bit in front of the vertical showing a clear uphill tendency and self-carriage; the basic is a clear three-time beat and a light steady contact with suppleness and elasticity.

#### 11. Extended Canter

In extended canter the horse covers as much ground as possible with obviously lengthened strides and frame; there should be no hurried strides and the nose should be always in front of the vertical not losing balance and with an uphill tendency. There should be clear transitions into and out of the extended canter.

#### 12. Simple change of leg at the canter

This is a movement in which, after a direct transition out of canter into a trot with three (3) to five (5) clearly defined steps, an immediate transition is made into the other canter lead.

#### 13. Rein Back

- 13.1. The horse must walk backwards in a straight line, with the legs being lifted and set down in diagonal pairs. The horse must remain on the bit, straight and not evade or resist the contact. The poll should remain the highest point.
- 13.2. Transition to the next movement must be immediate and smooth.

#### 14. Shoulder In

- 14.1. For four in hand shoulder in for the driven horse is performed in Collected Trot. The leaders are positioned so that the outside leader's tail is in front of the head of the pole. The leaders' shoulders are taken to the inside with a constant angle of approximately 30 degrees and a slight but consistent bend in the neck. The inside hind leg strides forward into the line of the outside front leg so that the horses are working on three tracks. Impulsion, rhythm and engagement must be maintained throughout.
- 14.2. Too much bend in the neck results in loss of rhythm and suppleness. The wheelers must remain straight with no counter bend.
- 14.3. For Single: shoulder in is performed in Collected trot. The Horse is driven with a slight but uniform bend maintaining engagement and cadence and a constant angle of approximately thirty (30) degrees. The Horse's inside foreleg passes and crosses in front of the outside foreleg; the inside hind leg steps forward under the Horse's body weight following the same track of the outside foreleg, with the lowering of the inside hip. The Horse is bent away from the direction in which it is moving.

#### 15. Diagonal Yield

Horse nearly parallel to centre line crossing legs diagonally, hind direction diagonal front, together with slight flexion to the inside.

#### 16. Stretching the frame

Letting the horse take the reins, stretching long and low – forwards and downwards at least to the point of the shoulder - over the back while keeping the same rhythm and impulsion. The driver must keep the reins without losing the contact and bring the horse back to the preceding elevation as soon as the stretching has been shown.

#### 17. Transitions

Changes of pace must always be made smoothly and promptly with the horse remaining in balance and on the bit. A transition must be completed as the nose of the (lead) horse arrives at the prescribed marker, unless otherwise stated.

## 18. Change of Pace and Movement

Changes of pace and movement are made when the noses of the leaders reach the point indicated in the test.

## 19. Terminology

The following must be considered when judging Driven Dressage movements:

19.1. Obedience and Lightness – willing response to aids without resistance, and correctness of bend.

19.2. Regularity – the regularity, evenness and rhythm with which the horse puts his feet to the ground.

19.3. Contact – the connection through the reins between the driver's hands and the horse's mouth. It should be soft and steady at all times.

19.4. Impulsion – the willingness of the horse to go forward energetically at all times and to respond quickly and evenly to changes of pace. The horse must remain in balance while maintaining the same tempo with strides of equal size.

19.5. Straightness – carrying the head, neck and body in a straight line with the weight evenly divided among the legs. On curved lines the hind legs need to follow the footprints of the fore feet (no escaping or swinging out).

19.6. Collection – roundness and engagement with good hock action, elevated poll allowing the shoulders to move with ease. The horse's energy is contained in a more deliberate pace than the Working pace.

The haunches are more compressed, the croup is lowered and the forehead elevated to the same degree. The stride is shorter but more powerful than the Working pace and the front legs will move from the shoulder with greater agility, resulting in lightness and greater mobility throughout. The neck should be more arched. The shortening of the frame is not, and never should be, a result of pulling back, but rather of asking and allowing the horse to move forward into the driver's hand.

19.7. Accuracy – correctness, roundness and correct size of figures and lines (including corners) as asked in the test.

## ARTICLE 955 GENERAL IMPRESSION

### 1. Principle

There are two boxes at the end of the Judges' Score Sheets for marks on Driver and General Impression & Presentation (five for novice class) observed by the judges throughout the whole test. Some tests also have boxes for Paces, Impulsion and Obedience and lightness observed by the judges throughout the test. Compulsory figures has neither.

### 2. Driver

2.1. Use of aids, handling of reins and whip, position on the box, accuracy of figures. The mark must reflect the consistent level of accuracy and quality of transitions.

2.2. Para Drivers in able bodied competitions may salute with a nod of their head only. Hats must not be removed at the salute, and contact must be maintained on the reins during the halt and salute.

2.3. Para Drivers are allowed to do one handed movements with two hands, if mentioned in the Master list following classification of the Driver.

### 3. General Impression & Presentation

Appearance of Driver and Grooms, correctness, cleanliness harmonising of harness and carriage. Fitness, matching and condition of Horse(s), balanced picture of the complete turnout. Clearance and fit of harness. Harmony between Horse(s) and Driver. For Novice classes the judge should not expect the standard achievable by more experienced drivers and should accept marathon harness and three phase vehicles without further penalty.

**1. Marks**

1.1. Marks out of 10 will be awarded for each numbered movement and for each heading under General Impression on the following basis:

- 10: Excellent
- 9: Very Good
- 8: Good
- 7: Fairly Good
- 6: Satisfactory
- 5: Sufficient
- 4: Insufficient
- 3: Fairly Bad
- 2: Bad
- 1: Very Bad
- 0: Not Executed

1.2. Half marks can be awarded.

1.3. Whenever a mark of 6.5 or less is given the judge must include a supporting comment in the box provided.

**2. Error of Test**

If a driver attempts to perform a movement, or attempts to maintain the pace required and fails to do so, but does not deviate from the track, the President of the Ground Jury may either treat it as an "Error of Course" (see paragraph 3 below), or they may decide to leave the Judges to give the movement an appropriate mark. If a driver makes no effort to perform a movement in a test, then it may either be treated as an Error of Test or as an Error of Course at the discretion of the President of the Jury.

**3. Error of Course**

3.1. An "Error of Course" is when a driver deviates from the required track or when a movement is performed at the wrong pace, or omitted altogether.

3.2. In the event of a driver making an Error of Course, the President of the Jury will ring the bell and stop the driver.

The driver must then resume the test from the beginning of the movement where the error was made. If the driver is in any doubt, they may ask the President of the Ground Jury for guidance, without incurring any further penalties.

**4. Disconnected or Broken Harness**

If the reins, pole strap, chains or trace become disconnected or broken, or should the horse get a leg over the pole, trace or shaft, the President of the Jury must ring the bell and a groom(s) must dismount and re-connect or repair as appropriate. The driver will be penalised for a groom(s) dismounting.

**5. Disobedience**

Any resistance in the forward movement, including kicking or rearing, is considered to be disobedience and will be penalised by the judge at C, as follows:

|                          |              |
|--------------------------|--------------|
| 1 <sup>st</sup> Incident | 5 penalties  |
| 2 <sup>nd</sup> Incident | 10 penalties |
| 3 <sup>rd</sup> Incident | Elimination  |

**6. Carriage overturn**

A carriage overturning is Elimination.

**7. Leaving the arena**

7.1. If part of the turnout leaves the arena during a movement the Driver will be marked down for inaccuracy.

7.2. If the whole turnout eaves the arena the Driver is Eliminated.

| Description  | Ref. Article       | Penalties   |
|--|--------------------|---|
| No hard hat for a person on carriage   | 928.7.1            | Elimination   |
| Part of the turnout leaves the arena during a movement                                       | 956.7.1            | Mark down for inaccuracy  |
| The whole turnout leaving the arena  | 956.7.2            | Elimination   |
| Driver dismounting   | 943.2.11 & Annex 8 | 20 penalties  |
| Entering the arena without a driving aid in hand   | 928.4              | 5 penalties   |
| Dropping or putting down a driving aid   | 928.4              | 5 penalties   |
| No breeching if carriage has no brakes   | 937.1.1            | Elimination   |
| No breeching for Singles   | 937.1.12           | Elimination   |
| Use of bandages or brushing boots (Horse to be inspected after Test) Hoof boots are allowed. | 940.2              | 10 penalties  |
| Contravening the Rules on Advertising  | 941                | Yellow Warning Card   |
| Person tied to the carriage  | 943.2.6            | Elimination   |
| Groom handles the reins, brake or uses the driving aid                                       | 943.2              | 20 penalties  |
| Groom speaking or giving indications (except as allowed)                                     | 945.2              | Elimination   |
| Physical outside assistance  | 945.1              | Elimination   |
| Groom(s) dismounting   | 943.2.12           | 1 <sup>st</sup> incident - 5 penalties<br>2 <sup>nd</sup> incident - 10 penalties<br>3 <sup>rd</sup> incident – Elimination |
| Early or late entry  | 952.1              | Possible Elimination  |
| Lame horse   | 952.3              | Disqualification of the horse and elimination of the driver   |
| Incomplete presentation (Driver, Groom)  | 928                | 5 penalties   |
| Errors of course:  | 956.3              | 1 <sup>st</sup> occasion - 5 penalties<br>2 <sup>nd</sup> occasion - 10 penalties<br>3 <sup>rd</sup> occasion - Elimination |
| Disobedience:  | 956.5              | 1 <sup>st</sup> incident - 5 penalties<br>2 <sup>nd</sup> incident - 10 penalties<br>3 <sup>rd</sup> incident – Elimination |
| Carriage overturn  | 956.6              | Elimination   |
| Someone other than driver driving within 60 minutes of test                                  | 943.2.7            | Elimination   |

**1. Total Marks**

- 1.1. The individual marks awarded by each judge for each movement and for General Impression will be added together and divided by the number of judges to obtain the average score.
- 1.2. In order to adjust the influence of Driven Dressage on the whole event, where the total possible marks for the test are other than 160, the average score will be multiplied by the coefficient printed on the score sheet to obtain the adjusted average score to be used in the results.
- 1.3. Penalties are only awarded by the President of the Jury at C.
- 1.4. Scores will be calculated to two decimal places.
- 1.5. The driver with the lowest score in penalties will be the winner of the Driven Dressage.

### ARTICLE 959 GENERAL

The objective of the Marathon is to test the fitness, stamina and training of the horses, and the driving skill and general horsemanship of the driver.

### ARTICLE 960 THE COURSE

#### 1. General

- 1.1. Maximum distances and speeds must not be exceeded.
- 1.2. The speeds may be reduced by the Technical Delegate and the President of Jury in the case of adverse weather or ground conditions.
- 1.3. Depending on the class the course will be one or two sections.
- 1.4. With previous approval by BC Council, a controlled warm-up can be used in place of Section A with a maximum time allowed of 30 minutes in a designated warm-up area with a minimum 5000 square metres, properly stewarded, with a judge in attendance.
- 1.5. The total distance in Section B should be approximately 1km per obstacle and not less than 250m between two consecutive obstacles. The total distance in Section B must include the distances through the obstacles. The first obstacle on Section B should be approximately 1km from the start, especially for classes that only have a Section B
- 1.6. It is recommended that the end of Section B should be a minimum of 500m from the nearest access to the box park.

#### 2. Neutral Zone

- 2.1. The distances between the end of Section A and the start of Section B (the Neutral Zone) must not be included in the total length of the course.
- 2.2. The neutral zone starts at the end of section A.
- 2.3. There should be water available for drivers to wash down if required in the neutral zone.
- 2.4. The neutral zone will vary in length to accommodate the distance between the end of section A and the start of section B.
- 2.5. A minimum of 10 minutes will be allowed to:
  - 2.5.1. get green cards signed at the end of Section A
  - 2.5.2. wash down
  - 2.5.3. progress to the start of section B.
- 2.6. The time allowed will be set by the TD and published with the marathon information.
- 2.7. This time will vary depending on length of Section A, ground conditions, temperature, etc.
- 2.8. Before the start of section B and still within the neutral zone there may be a simple obstacle to prepare the turnout before the start of section B.
- 2.9. Extra time should be allowed if an obstacle is provided.
- 2.10. The driver will present themselves to the start of section B, for the timekeeper to complete the green card with their start time.
- 2.11. The neutral zone will, where possible, be as short as possible, in a shaded area and have good supply of water with room for multiple turnouts.

### 3. Marathon sections

| Section                                       | Maximum Distance | Minimum Distance | Pace | Speed - km/hour |       |
|---|------------------|------------------|------|-----------------|-------|
|   |                  |                  |      | Horse           | Pony  |
| A *   | 9000 m           | 3000 m           | free | 12-15           | 11-14 |
| B   | 9000 m           | 5000 m           | free | 14              | 13    |
| Variations of Section B for specific classes: |                  |                  |      |                 |       |
| Sec B SE                                      | 9000 m           | 5000 m           | free | n/a             | 11    |
| Sec B VSE                                     | 4000 m           | 2000 m           | free | n/a             | 10    |
| Sec B Junior YD and U25 championships         | 8000 m           | 4000 m           | free | 12-14           | 11-13 |
| Sec B Children                                | 9000 m           | 4000 m           | free | n/a             | 11-13 |

***\*Pre-Novice, VSE and Small Equine classes do not drive Section A. Gateway classes do not drive marathon sections, only a maximum of 4 obstacles.***

4. A safety check of the turnout (including any quick release system for Drivers with Disabilities) must be made before the start of Marathon
5. **Section and direction signs**
  - 5.1. The beginning and end of each section must be marked with a pair of red and white flags.
  - 5.2. The entire course must be clearly marked with easily identifiable directional markers, positioned—wherever possible—on the right-hand side of the track for maximum visibility to approaching drivers. A confirmation arrow must be placed after every significant turn to indicate the correct direction. Sections A and B must have a marker at every kilometre. In Section B the measurement of the kilometres must include the distances through the obstacles.
  - 5.3. The marker for a kilometre occurring within an obstacle should be placed on the post supporting the red exit flag.
6. **Compulsory turning flags**
  - 6.1. Sufficient red and white Compulsory Turning Flags (CTFs) must be positioned on the course to ensure that all drivers follow the designated track. Drivers must leave the red flags on their right and the white flags on their left. These compulsory turning flags must be numbered consecutively in each section, and they must be placed so they are clearly visible to drivers from a reasonable distance.
  - 6.2. The location and number of the flags must be marked on the map of the course to clearly indicate the correct route to be driven between the compulsory turning flags before and after each obstacle. In addition, a list showing the order for driving compulsory turning flags and obstacles should be provided for drivers and officials.
  - 6.3. Obstacle or section start finish stewards may record if any compulsory turning flags are missed out or passed in the wrong sequence. The details must be reported to a member of the Ground Jury or the Technical Delegate as soon as possible.
7. **Paces**
  - 7.1. The finish of Section B must not be more than 300m from the exit of the last obstacle unless the Technical Delegate grants an exception. A sign clearly indicating the distance to the finish should be positioned at the exit of the last obstacle. If the last obstacle is situated within 300m of the finish, the drivers may stop within 30m of the out gate of the obstacle to repair broken or detached harness without penalty. A 30m marker will be

placed on the track to indicate this point if the last obstacle is within 300m of the finish. In this situation, any pace may be undertaken until the 30m mark.

- 7.2. Between the 30 m marker of the last obstacle (or 300m) and the finish, the pace must be trot or walk only. The driver will accumulate one penalty point for each 5 seconds the turnout is not at the walk or trot.

## ARTICLE 961 OBSTACLES IN SECTION B

### 1. Number of Obstacles

- 1.1. The maximum number of obstacles, natural or artificial, is 4 for VSE and Gateway, 5 for Children (A-D only), 6 for Pre-Novice, Small Equine, Drivers with Disabilities, Juniors, Young Drivers, U25 championships and Novice Classes, and 8 for all other classes. The British Carriagedriving National Championships should ideally have the maximum permitted number of obstacles for each class.

### 2. Sketches of Obstacles

- 2.1. Accurate sketches of each obstacle showing the location of the compulsory gates, dislodgeable/detachable knock downs and entry/exit flags must be made available to drivers and event officials before the first inspection of the course. See Art 962 2.4 for required time-frames.

### 3. Design and Construction of Obstacles

- 3.1. The number of each obstacle must be clearly displayed on the post supporting the red entry flag.
- 3.2. The entry and exit of each obstacle must be marked by red and white flags (red on the right and white on the left), not less than 20m from the nearest lettered gate, unless the Technical Delegate grants an exception. After the finish line of each obstacle a 30 m sign must be established. A dismounted groom in an obstacle must be back on the carriage before the rear axle passes the sign. The carriage must be stationary when the groom(s) remount the carriage
- 3.3. The track through an obstacle should not exceed 250m on the shortest 2.5m drivable route (that is not narrower than 2.5m at any point between the entry and exit flags). The track may exceed 250m in exceptional circumstances at the discretion of the Technical Delegate.
- 3.4. Obstacles must be at least 250m apart unless the Technical Delegate grants an exception.
- 3.5. Obstacles must be clearly numbered in the sequence in which the drivers are required to drive them.
- 3.6. Obstacles must not include any feature which might cause damage or injury to the horses.
- 3.7. Fixed obstacles are those which are solidly constructed and firmly fixed, so that they are unlikely to be moved or broken during the competition. Free standing ("mobile") obstacles should be solidly constructed with knockdowns for protection and clearly marked on the ground, so that the elements can be replaced if moved or broken during the competition. In case of doubt, the definition of fixed obstacles is to follow the FEI's guidelines.
- 3.8. If the Course Designer includes any element in an obstacle, which in the opinion of the President of the Jury and / or Technical Delegate could frighten the horses, an alternative route must be provided within the obstacle.
- 3.9. Where a constructed water crossing is included in an obstacle, the depth of the water must not be more than 30cm. Where natural water is used the Technical Delegate may allow a maximum depth of 50cm. The bed of any water crossing must be firm. Where water depth exceeds 50cm a substantial fence, firmly fixed, must be constructed, to prevent horses going into deep water.
- 3.10. If a barrier for crowd restraint is required by local regulations or the organiser, it must not be positioned closer than 20m from the nearest element in the obstacle unless the Technical Delegate grants an exception.

### 4. Compulsory gates

- 4.1. Obstacles may include up to six compulsory gates (five for Gateway and four for Children) marked with red and white letters, which should be lettered alphabetically starting from A, indicating the sequence in which they must be driven. All markers must also have small letters visible from all angles, where practical.

- 4.2. As an alternative option, a maximum of two letters can be used twice in the same obstacle.
- 4.3. The height of a compulsory gate or any single post must not be less than 1.3m.
- 4.4. For fixed obstacles the minimum width of a compulsory gate is 2.5 m. For mobile obstacles a minimum width of 3m for each compulsory gate is required.

## 5. Dislodgeable/detachable elements

- 5.1. The Course Designer may choose any type of dislodgeable or detachable knock down, with a preference for balls such as used in cones.
- 5.2. No dislodgeable or detachable element should interfere with, or cause injury to the horse, or damage to the carriages, when they are dislodged. A dislodgeable element consisting of a free-standing pole, the whole of which can fall over, is not allowed.
- 5.3. The cup that holds the ball on a dislodgeable element should be a standard 45 - 55mm pipe to hold the balls from the cones driving competition. The cups must be of sufficient depth so that the ball does not rest on the post.
- 5.4. The number of dislodgeable or detachable knock downs must not exceed 24 in total on fixed obstacle elements. In addition, mobile obstacles and mobile elements of fixed obstacles must have one dislodgeable/detachable knock down on each element.
- 5.5. Drivers will incur 2 penalties for each knock down dislodged.
- 5.6. A dislodgeable or detachable element is "live" at all times until it is dislodged or completely detached.
- 5.7. A driver or groom who attempts to prevent a dislodgeable or detachable element from being dislodged will incur 10 penalties.

## ARTICLE 962 INSPECTION OF THE COURSE

### 1. Visit of the Technical Delegate

At least three days before the start of the marathon, the entire course, including the obstacles, must be available for inspection and approval by the Technical Delegate.

### 2. Briefing for Drivers and Officials

- 2.1. If possible, the Technical Delegate should arrange a briefing for members of the Ground Jury prior to the official opening of the course.
- 2.2. Ground Observers, Obstacle Observers and Time Keepers must be briefed by the Technical Delegate or his designated representative before the start of marathon.
- 2.3. Copies of maps of the entire course must be available at the briefing, for those requiring them. The maps must show each section, the location of all the obstacles and numbered compulsory turning flags, kilometre markers, and any areas of the course which are closed to motor vehicles.
- 2.4. Drawings of the obstacles must be available to drivers at least 2 days before the start of the event As an alternative to providing paper copies, the course maps and obstacle diagrams may be posted on the internet for drivers, provided this is done at least one day before the stable field opens so those who wish can print diagrams before arriving at the event.
- 2.5. If an online noticeboard is used by the event organiser, there should also be a physical noticeboard available displaying the same information.
- 2.6. A list showing the order for driving compulsory turning flags and obstacles must be made available.
- 2.7. The Technical Delegate and the Course Designer must be available to answer questions at a published time the evening before the marathon is due to start. This must be made known to all drivers.

### 3. Inspection of the Course by Drivers

- 3.1. At least 48 hours before the first driver is due to start the marathon, Section B must be open for inspection by the drivers, except under exceptional circumstances with the agreement of the Technical Delegate.
- 3.2. The Technical Delegate may impose restrictions on the means of access to certain parts of the course.
- 3.3. The obstacles in Section B may be left open until the first driver starts Section B.
- 3.4. Drivers using motor vehicles must remain on the roads and tracks designated by the Technical Delegate. The course is closed to motor-vehicles unless otherwise notified in the event paperwork. Drivers and grooms will be allowed to

inspect Section B on foot (or by bicycle at the organisers discretion), and organisers must provide a well-marked map of the course.

- 3.5. The obstacles may only be inspected on foot. No motor vehicles or bicycles may be taken inside any part of an obstacle or the Controlled Warm up. Failure to comply will be penalised by the issue of a warning for the first infringement and a Yellow Warning Card for the second. Drivers with disabilities must obtain permission from BC to use a motorised vehicle to inspect the course and the vehicle must be clearly identified. Permission must also be gained from the Organising Committee. Identification can be obtained from the British Carriage Driving office.
- 3.6. DWD permissible-vehicles must be driven at no more than 5kph within the confines of the obstacle.
- 3.7. Anyone riding or driving a motorised vehicle within the Event Location must hold an appropriate driving licence and insurance.
- 3.8. Drivers may not ride or drive their horses on or over any part of the marathon course unless the course incorporates the public highway or is part of the official exercise route, nor enter the dressage or obstacle driving arenas, except when actually competing, unless they have express permission to do so.
- 3.9. Drivers must not ride a horse, or drive any horse drawn vehicle through the obstacles in the 4 days prior to the event in which they are competing, or after an obstacle has been flagged for the event.
- 3.10. If the driver or any of his team fails to comply with Article 962.3, he is liable to a fine at the discretion of the Ground Jury.

## ARTICLE 963 TIMES

### 1. Timetable

- 1.1. A timetable showing the start of Section A or Controlled Warm up and the timetable of each section, including the compulsory rest, must be drawn up by the Organising Committee for the Ground Jury and Technical Delegate. It must be adjusted in the event of unforeseen circumstances and redistributed.
- 1.2. A timetable showing the section times for each driver must be provided to all Drivers, Timekeepers, Ground Observers, Obstacle Observers, and the Ground Jury.

### 2. Times in Sections

- 2.1. The Time Allowed in all sections is calculated according to the speed selected for that section.
- 2.2. The Minimum Time in Section A is two minutes less than the Time Allowed.
- 2.3. The Minimum Time for Section B is three minutes less than the Time Allowed.
- 2.4. The Time Limit for Section A is the Time Allowed plus 20%. The Time Limit for Section B is twice the Time Allowed.
- 2.5. A driver who exceeds the Time Limit in any section will be eliminated.

### 3. Timing

- 3.1. Electronic timing equipment should be used for the timing of drivers in each section and the obstacles, whenever possible.
- 3.2. Time Keepers at the start and finish of each section must record the start and finishing times for each driver on the Section Timer Record and enter the time on the driver's Marathon (Green) Time Card.

### 4. Start and Finish

- 4.1. Drivers should present to the start of Section A or the Controlled Warm up at least 10 minutes before their published Start Time. A safety check of the turnout (including any quick release system for Drivers with Disabilities) must be made before the start of Marathon. Failure to present to the safety check is Elimination.
- 4.2. If a driver is not ready to start Section A or the Controlled Warm up at the scheduled time, the Timekeeper will start the driver at the earliest available time at their discretion, and record the actual starting time, which must be reported to the Technical Delegate and President of Jury for onward transmission to the scorer at the earliest opportunity. The driver will be penalised 0.25 of a penalty per second of the time elapsed between the scheduled start time and the actual time the driver started. The driver must not be allowed to start less than two minutes before the next driver's starting time. For the avoidance of doubt, drivers will not be penalised where the start of Section A is delayed for organisational reasons.
- 4.3. Drivers must start each section from the halt with the leading horse behind the start line. The Timekeeper will count down to the start time. If a driver starts before the Timekeeper gives him authorisation, the driver will be recalled, a new start time will be given and the Marathon Time Card will be amended. If the driver fails to stop

when recalled, the driver may be eliminated. A member of the Ground Jury must be made aware of the circumstances as soon as possible.

4.4. The timing of the section ends when the nose of the leading horse has passed the finish line. Section penalties will apply until the whole turnout has passed the finish line. These times must be recorded to the nearest second.

#### **5. Time Penalties in the Sections**

5.1. In all sections, drivers will be penalised 0.25 of a penalty per second for exceeding the Time Allowed.

5.2. Drivers completing Section A and Section B in less than the Minimum Time will be penalised 0.25 of a penalty point for each second they are early.

### **ARTICLE 964 PENALTIES ON THE MARATHON COURSE**

#### **1. Driving aids**

1.1. Driving aids, if carried, may only be used by the driver. Failure to comply will incur 20 penalties. Dwd exception see 928.5.2.

#### **2. Error of Course**

2.1. Once a driver has passed through a Compulsory Turning Flag (CTF) in the correct sequence/direction, it becomes "Neutralised/Free". Drivers may, therefore, after neutralising a CTF go through the CTF again in any direction at any time.

2.2. Drivers who pass through a Compulsory Turning Flags in the wrong sequence or direction before it becomes "Neutralised/Free" will be Eliminated.

#### **3. Deviation from the Course**

3.1. Drivers must not deviate from the track for the last 300m of Section B. Drivers who stop, circle, zig-zag or leave the track in any other way will incur 10 penalties for each occurrence.

3.2. Exception: See Article 960.7

#### **4. Incorrect pace**

4.1. Should one or more horses break into a canter within the last 300m before the finish of Section B and this is not corrected within 5 seconds, the driver will incur one penalty for every occurrence. If the break continues, the driver will incur one penalty for every additional completed period of 5 seconds.

#### **5. Dismounting in the Sections**

5.1. Outside the obstacles in Section B, grooms and drivers are not allowed to dismount unless the carriage is stationary. If the carriage is not stationary, either or both groom(s) dismounting will incur 5 penalties (exception: to permit safe road crossing). The driver dismounting will incur 20 penalties.

5.2. The driver and all grooms must be on the carriage as it crosses the start and finish line and passes through the compulsory turning flags in each section. Failure to do so incurs 5 penalty points for grooms and 20 penalty points for the driver on each occasion.

5.3. In exceptional circumstances, if warranted due to the condition of the terrain or weather, the Technical Delegate and the President of the Jury may permit grooms in competitions for ponies and single horses to run behind their carriage on designated parts of the course.

#### **6. Stopping**

6.1. Drivers may stop for repairs to carriages or harness or for any reason beyond the driver's control anywhere on the course other than while negotiating an obstacle, without incurring penalties other than loss of time, except after the last obstacle.

6.2. Drivers will incur 1 penalty point for each commenced 10 seconds that they remain stopped on the course in Section B for any other reason.

6.3. If an obstacle is situated within 300m of the finish line, a driver is allowed to stop to carry out necessary repairs to the harness or carriage without penalty as long as the driver stops within the signed 30m after leaving the last obstacle. Stopping for any other reason between the last obstacle or the 300m sign, whichever is closer to the finish line in Section B, will incur 10 penalties for each occurrence.

#### **7. Damaged Carriage/Harness**

- 7.1. At the finish of Section B any missing or disconnected trace, pole strap or reins will incur 10 penalties for each occurrence.
- 7.2. At the finish of Section B a broken or disconnected pole or shaft or bit will incur Elimination.
- 7.3. Carriages must pass the finish of Section B drawn by the number of horses required for its class and on the designated number of wheels. Failure to comply will incur elimination. Broken or missing tyres are acceptable.
- 7.4. If the carriage overturns (on the course or in an obstacle), the penalty is Elimination and the driver may not continue on the marathon.

## ARTICLE 965 OBSTACLE PENALTIES

### 1. Pace in Obstacles

- 1.1. Drivers may use any pace in the obstacles.

### 2. Error of Course in an Obstacle

- 2.1. Drivers entering any part of an obstacle without first passing through the entry flags or failing to pass through the exit flags on leaving an obstacle without correcting the error will be Eliminated.
- 2.2. The compulsory gates in an obstacle are “free” after a driver has passed through them in the correct direction and in the correct sequence. Drivers may, therefore, go through them again in any direction at any time. For example, drivers must go through A in the correct direction before going through B. A is now “free” and they may go through it again in any direction as often as they like, and so on.
- 2.3. Drivers who pass through a compulsory gate in the wrong sequence or direction before it becomes “free”, and without correcting the error before passing through the exit flags, will be Eliminated (20 penalties Gateway).
- 2.4. In order to correct an Error of Course, the driver must return to and drive the compulsory gate they missed before continuing through the next compulsory gate in the correct sequence. For example, a driver drives through compulsory gates A and B and then goes through D, missing gate C. In order to correct this error of course, the driver must go back and drive through gate C before going on to drive gate D again and then the remainder of the compulsory gates etc. All gates are neutralised until they reach this gate. Each error corrected shall incur 20 penalties (10 penalties Gateway).
- 2.5. Passing through the exit gate of an obstacle without driving all compulsory gates in the correct sequence will be penalised by Elimination.
- 2.6. A driver is not considered to have passed through a compulsory gate in an obstacle until the ‘whole turnout’ has passed between the flags denoting the compulsory gate.

### 3. Dismounting in the obstacles

- 3.1. Each time either or both grooms put both feet on the ground in an obstacle, the driver will incur 5 penalties.
- 3.2. Once grooms have dismounted, they are not required to get back on the carriage and need not follow the driver through any of the compulsory gates in the rest of the obstacle. Grooms do not have to be on the carriage when it leaves the obstacle. They must get back on the carriage immediately (between the finish line of each obstacle and the 30 m sign) outside of the obstacle. Failure to do so will incur 5 penalties per incident. The carriage must be stationary when they remount the carriage.
- 3.3. Each time a driver dismounts in an obstacle he will incur 20 penalties. The driver must be on the carriage when it leaves the obstacle.
- 3.4. In all incidents (for example trace or reins or lead bar over a part of the obstacle etc.) the grooms must dismount and solve the problem (no climbing over horses or pole). Failure to comply will incur 20 penalties.
- 3.5. A driver or groom may only put one foot on any part of an obstacle without incurring penalties. Contravention will result in 5 penalties.
- 3.6. A groom may assist the driver by leading a horse through the obstacle by the bridle end of the reins or otherwise (945 3.2). The driver will incur 25 penalties in total (20 for leading, 5 penalties for groom down).
- 3.7. Groom(s) must be on the carriage when the Driver enters each obstacle on the Marathon. Failure incurs 5 penalties.

#### **4. Disconnecting**

4.1. Deliberately disconnecting one or more horses and leading them through any part of the obstacle will be penalised by Elimination.

#### **5. Elimination in an Obstacle**

5.1. The decision whether a driver is Eliminated in an obstacle rests entirely with the Ground Jury.

#### **6. Welfare of the Horse**

6.1. It is the responsibility of the driver to stop immediately and put a groom or grooms down whenever a horse has its leg over a pole, shaft or trace, when a wheeler has a leg over the lead bar or the leader's trace, or when a horse is down and remains down. Also, the driver must stop to make necessary repairs when instructed to by a member of the Ground Jury or Obstacle Observer. However a trace down or a pole strap disconnected needs no mandatory repair or stop inside an obstacle. The time will continue to run.

6.2. Failure to stop and put the groom down to correct the situation before leaving the obstacle will incur Elimination.

#### **7. Timing**

7.1. The driver will be timed from the moment when any part of the turnout crosses between the entry flags until any part of the turnout passes between the exit flags from the right direction. Other penalties can still accrue until the whole turnout has exited the obstacle.

7.2. Electronic timing equipment should be used to time drivers through the obstacles if at all possible.

7.3. The Time Limit for drivers in obstacles is 5 minutes. If a driver fails to complete the whole obstacle and pass the exit flags within the Time Limit, the Obstacle Observer is to blow two blasts on a whistle indicating to the driver that the Time Limit has been reached. The driver must then vacate the obstacle as quickly as possible (with assistance if necessary) and may not continue in the competition.

7.4. The time taken for a driver to complete an obstacle shall be recorded to one hundredth of a second, either manually or electronically.

#### **8. Hold Ups**

8.1. If a driver arrives at an obstacle while the previous driver is still negotiating the obstacle, or if the obstacle is not ready to be driven, the driver is to be held at a safe point on the course preferably no closer than 50m from the entry flags.

8.2. One of the Assistant Obstacle Observers is to stop the driver at that point and start a stopwatch. As soon as the previous driver is clear of the obstacle and the Obstacle Observer approves a re-start, the Assistant Obstacle Observer will re-start the driver, informing them of the time they have been held. This should be recorded in whole minutes.

8.3. In the event of an accident or mishap the Obstacle Observer or other accredited official at an obstacle can stop a driver once he has completed the obstacle, until such time as a medic, veterinary surgeon or other appropriate official has checked the fitness to continue of the driver, the grooms, horses/ponies, vehicle and harness. The 'Hold Up' time will be deducted from the overall time for the section.

### **ARTICLE 966**

### **JUDGES**

#### **1. Positions**

1.1. One member of the Ground Jury or a suitable person must be at the start of Section A, to ensure that all drivers and grooms are wearing a suitable body protector and protective headgear; to ensure that no drivers (other than drivers with disabilities) are tied to the carriage; and to inspect the harness and turnout for safety in all classes other than Open and Advanced.

1.2. One member of the Ground Jury should be at the end of Section B to supervise the inspection of carriages, harness and marathon time-cards.

1.3. The rest of the Jury will be positioned by the President of the Jury.

**1. Ground Observers**

- 1.1. Ground Observers should be allocated positions around the course by the Technical Delegate from which they can observe the most critical compulsory turning flags.
- 1.2. Ground Observers must be given the starting order of drivers, together with copies of Instructions, the Ground Observers Report and a Control Sheet.
- 1.3. Ground Observers must report all incidents for which a driver may be penalised, and any other information, to the President of the Jury or member of the Ground Jury periodically and at the end of their period of duty.
- 1.4. Ground Observers cannot eliminate or otherwise penalise drivers. It is the responsibility of the Ground Jury to impose appropriate penalties.
- 1.5. After the competition, Ground Observers must remain in the vicinity of the Secretary's Office until dismissed by the President of the Jury.

**2. Timekeepers**

- 2.1. Each timekeeper will be provided with a clock with a "time of day" display and instructed in its use by the Technical Delegate. The Technical Delegate or their assistant is responsible for the synchronisation of the "time of day" on all chronometers issued to officials.
- 2.2. The timekeeper at the start of Section A must be issued with the starting time schedule and must ensure that drivers have been given a 'Marathon Time-Card' (Green Card).
- 2.3. All other Timekeepers at the start and finish of each section, must be provided with the complete list of drivers and a running order.
- 2.4. Timekeepers are required to record the start or finish times for their respective section and to enter them on the driver's 'Marathon Time-Card' and the 'Section Time Record' and a "Master Section Time Record" held by the timekeeper.
- 2.5. Horses must start from the halt with the nose of the leading horse behind the start line.
- 2.6. The finishing time will be taken as the nose of the leading horse crosses the finish line. The section is finished as the rear axle has passed the finish line.
- 2.7. After the competition, Timekeepers must remain in the vicinity of the Secretary's Office until dismissed by the President of the Jury.

**3. Obstacle observers**

- 3.1. There must be one Obstacle Observer at each obstacle. Each Obstacle Observer must have at least two assistants. The Obstacle Observer must be given a whistle and at least two stopwatches and instructed in their use by the Technical Delegate or their assistant. They must record the exact time taken by each driver through the obstacle to 1/100<sup>th</sup> second.
- 3.2. Obstacle Observers must be given a starting order listing all drivers together with sufficient copies of obstacle reports and diagrams to record each driver's time and the sequence of the gates through the obstacle as driven.
- 3.3. In case of an incorrect sequence of the gates, a drawing of the route must be recorded.
- 3.4. Obstacle observers must record and report all incidents to a member of the Ground Jury as soon as possible after the incident occurred.
- 3.5. After the competition, the lead Obstacle Observers must remain in the vicinity of the Secretary's Office until dismissed by the President of the Jury.

**1. Conversion of time to penalties**

- 1.1. The total time taken by the driver in the obstacles will be recorded to hundredths of a second and penalties will be calculated to two decimal places. Any time over the Time Allowed in each of the sections will be multiplied by 0.25. Any time under the Minimum Time in Sections A and B will be multiplied by 0.25. The penalties for under Minimum Time plus penalties for over Time Allowed and the total obstacle times shall be added to any other driving penalties received, to determine the final score for each driver in the marathon.
- 1.2. For drivers who are eliminated or retire, see Article 911.
- 1.3. The driver with the lowest number of penalties will be the winner of the competition.
- 1.4. In the event of an equality of penalties, the drivers will be placed on equal rank.

ARTICLE 969 SUMMARY OF PENALTIES IN MARATHON

Drivers are liable to the following penalties:

| Definition   | Ref. Article    | Penalties   |
|--|-----------------|---|
| Driver or Groom wearing shorts.  | 928.2           | 10 penalties per person                                   |
| No protective headgear or no body protector on marathon.   | 928.2           | Elimination   |
| Finishing Section B with fewer horses than required.   | 931             | Elimination   |
| No breeching with a carriage with no brakes.   | 937             | Elimination   |
| No breeching for Singles   | 940             | Elimination   |
| Substitution of a Groom.   | 943.2           | Elimination   |
| Groom handling reins, or using driving aid or brakes when carriage not stationary.                                   | 943.2.5         | 20 penalties  |
| Person tied to the carriage  | 943.2.6         | Elimination   |
| Outside Assistance.  | 945.2.2.2       | Elimination   |
| Groom leading a horse through an obstacle.   | 945.3           | 25 penalties (20 for leading & 5 for dismounting)         |
| Incorrect pace   | 960.6.2 & 964.4 | 1 penalty for every 5 sec.                                |
| Dislodging a dislodgeable element  | 961.5.5         | 2 penalties per occurrence                                |
| Preventing a dislodgeable element from being dislodged   | 961.5.7         | 10 penalties  |
| Motorised vehicles or bicycles in obstacles.   | 962.3.5         | First Incident - Warning<br>Second Incident - Yellow card |
| Carriages under weight at end of B or under width at start of B.   | 937 & 966.1     | Elimination   |
| Total time over Time Allowed in any section  | 963.5.1         | 0.25 penalties/sec.                                       |
| Total time under Minimum Time in Section A and B   | 963.5.2         | 0.25 penalties/sec.                                       |
| Total time in obstacles.   | 968.1.1         | 0.25 penalties/sec.                                       |
| Driver fails to stop when recalled   | 963.4.3         | Elimination   |
| Not ready to start Section A.  | 963.4.2         | 0.25 penalties/sec.                                       |
| Contravening the rule on the use of the driving aid  | 964.1           | 20 penalties  |
| Each deviation from Course after last obstacle.  | 964.3           | 10 penalties  |
| Required persons not on carriage passing through a compulsory turning flag, or the start and finish of each Section. | 964.5           | 5 penalties each occasion                                 |

|  |         |                           |
|--|---------|---------------------------|
| Grooms dismounting while moving in Section B.  | 964.5   | 5 penalties               |
| Driver dismounting while moving in Section B.  | 964.5   | 20 penalties              |
| Finishing Section B with missing or disconnected Pole strap, trace or reins for each occurrence. | 964.7   | 10 penalties              |
| Failing to pass through compulsory turning flags and obstacles in correct sequence and direction | 964.2   | Elimination               |
| Finishing Section B with missing wheel.  | 964.7   | Elimination               |
| Finishing Section B with broken or disconnected pole or shaft                                    | 964.7   | Elimination               |
| Failing to pass through entry flags of an obstacle.  | 965.2   | Elimination               |
| Groom(s) not on the carriage when crossing start of an obstacle                                  | 965.3.7 | 5 penalties               |
| Grooms not remounting on the carriage immediately outside of an obstacle (per incident)          | 965.3.2 | 5 penalties               |
| Failing to pass through exit flags of an obstacle within 5 minutes.                              | 965.7.3 | Elimination               |
| For correcting each error of course in an obstacle.  | 965.2   | 20 penalties (10 Gateway) |
| Uncorrected error of course (Missing a gate)   | 965.2   | Elimination (20 Gateway)  |
| Passing between exit flags before completing an Obstacle.  | 965.2   | Elimination               |
| Groom(s) dismounting in an obstacle, each occasion.  | 965.3   | 5 penalties               |
| Driver dismounting in an obstacle.   | 965.3   | 20 penalties              |
| Two feet on an element of obstacle.  | 965.3   | 5 penalties               |
| Groom climbing over horse back or down the pole in an obstacle                                   | 965.3   | 20 penalties              |
| Disconnecting and leading through an obstacle.   | 965.4   | Elimination               |
| Failing to stop for leg over pole, lead bar or shaft.  | 965.6   | Elimination               |
| Failing to stop for leg over trace.  | 965.6   | Elimination               |
| Carriage overturn  | 964.7.4 | Elimination               |
| Exceeding the time limit in obstacles (5 mins)   | 965.7.3 | Elimination               |
| Horses unfit to continue in Neutral Zone   | 966.1   | Elimination               |
| Exceeding the time limit in any section  | 968.1.1 | Elimination               |

## CHAPTER XIII – CONES

### ARTICLE 970 GENERAL

The Cones Competition is to test the fitness, obedience and suppleness of the horses, and the skill and competence of the drivers.

### ARTICLE 971 COMPETITIONS

1. The competition is conducted on the basis of penalties for obstacles knocked down and for exceeding the Time Allowed.
2. Drivers can salute the cones judge on the move.

### ARTICLE 972 THE COURSE

#### 1. Building and Measuring the Course

- 1.1. The Course Designer is responsible for laying out, marking and measuring the course and building the obstacles. The Course Designer must indicate with a dotted line on the course plan how the length of the Course was measured. The President of the Jury and Technical Delegate must ensure that the length of the course is measured accurately. The Technical Delegate must also ensure that all elements of the course do not contravene any rules or put equine welfare at risk.
- 1.2. The arena should be not less than 5000 m<sup>2</sup>, with a minimum width of 40m or an equivalent area. Should this not be possible the number of obstacles must be reduced accordingly, unless an exception is granted by the Technical Delegate.
- 1.3. The starting and finishing lines may not be more than 40m nor less than 20m from the first and last obstacles respectively.
- 1.4. The number of obstacles may not exceed 20 and for Children class may not exceed 15.
- 1.5. The length of the course must be between 500m and 800m. For Children class it may be shorter.
- 1.6. Courses must be laid out so that drivers have a chance to maintain a flowing pace throughout the major part of the course. Certain obstacles and combinations of obstacles, such as open and closed multiples, will inevitably slow down the pace but such a layout should be limited to a small proportion of the whole course.
- 1.7. All obstacles should be visible from the Judges' Box.
- 1.8. The President of the Jury must walk the course to inspect it before the start of the competition. The course is the track which the driver must follow when competing, from passing the start in the correct direction up to the finish. The length must be measured accurately to the nearest metre, taking account, particularly on the turns, of the normal line to be followed by the horse(s). This normal line must pass through the middle of the obstacles. If there is an alternative obstacle, the official distance must be measured by the longest route.

### ARTICLE 973 OBSTACLES

#### 1. Cones

- 1.1. The cones forming an obstacle must be at least 30 cm high and made of durable plastic material. A weighted ball must be placed in the hollow on top of the cone, so that it falls down only if the cone is touched.
- 1.2. All obstacles consisting of a single pair or double pair (oxer) of cones will constitute a single obstacle.
- 1.3. The obstacle includes the cones, red and white markers, numbers and letters.
- 1.4. The position of one of the pair of cones must be marked on the ground so that a constant position of the obstacle is maintained throughout the competition. Where practicable a line will also be drawn to ensure that the other cone is maintained at the correct angle.
- 1.5. Obstacles that entail reining back are not permitted.
- 1.6. An oxe will be composed of two pairs of cones in a straight line. The distance between the first set of cones and the second set will be between 1.5 and 3 metres at the option of the Course Designer. The maximum penalties per

Oxer is 3 penalties for hitting one to four balls. The first set of cones will have the number of the obstacle, the second will only be marked with red and white flags.

1.7. A maximum of five oxers are allowed in a Cones course.

## 2. Multiple obstacles

2.1. Multiple obstacles must conform to the design principles.

2.2. Variations or new designs must be pre-approved by the British Carriagedriving Council and included in the event schedule.

2.3. A multiple obstacle may be constructed of markers or horizontal rails, elevated to a minimum of 40cm and maximum of 60cm in height.

2.4. Each group of cones or elements must be clearly separated and associated with one of the sections of the multiple.

2.5. A multiple obstacle, other than a Zig- Zag, a Double Box, a Double U or a Wave, must not consist of more than three pairs of cones or dislodgeable elements.

2.6. Other than Zig-Zags, Double Boxes, Waves and Double U's, a multiple obstacle may not be longer than 30m measured along the centre line through the obstacle.

2.7. There may not be more than 3 multiple obstacles in any course.

2.8. In multiple obstacles, drivers can only incur a maximum of 6 penalties in a Double (A & B), 9 penalties in a Triple (A, B & C) and 12 penalties in a Zig-zag, Double Box, Wave or Double U (A, B, C & D) per attempt, plus any penalties for a rebuild as well as penalties for disobedience.

## 3. Zig-Zags, Double Boxes, Double U and Wave

3.1. A Zig-zag consists of not more than 4 pairs of cones, with alternate left and right cones in a straight line. All centre line cones must be placed in a straight line, either at the front, middle or rear of the cone.

3.2. A Double Box, a Double U and a Wave.

## 4. Water and bridges

4.1. Where Water obstacles and Bridge obstacles are included in the course, prior notification must be given in the schedule for the event.

4.2. Water obstacles must be at least 3m wide, with a depth between 20cm and 40cm and sloping sides. There must be a pair of cones at the entrance (flag lettered A) and exit (flag lettered B) with the cones 2m apart.

4.3. Knocking down a ball or balls on either A or B will be penalised as 3 penalties for each pair of cones.

4.4. Wooden bridges, or bridges of similar suitable construction approved by the Technical Delegate, with fan shaped wings at the entrance, with the bridge surface not more than 20cm above the ground, with a usable width of 3m, and a maximum length of 10m are permitted. Boarded or railed sides are essential. The Technical Delegate may grant exceptions if the bridge is of a permanent solid construction with strong side rails. There must be a pair of cones at the entrance (flag lettered A) and exit (flag lettered B) with the cones at least 2m apart.

## 5. Markers

5.1. Each obstacle is defined by a pair of markers; a red marker on the righthand side and a white marker on the lefthand side as drivers approach the obstacle. They are placed not more than 15cm outside the elements which form the single and multiple obstacles.

5.2. The whole turnout must pass between the markers. Failure is considered as disobedience (see Article 975.7).

5.3. Decorations and obstructions must be placed on the course before the official course walk. No penalty is incurred if they are touched, displaced or knocked over.

5.4. All obstacles on the course must be numbered in the sequence in which they are to be driven. The number of each obstacle must be indicated on a marker placed at the entrance to each single and multiple obstacle.

5.5. Each distinct section of a closed multiple obstacle (L's, U's and Boxes) must be clearly marked in different colours (see Annex 4). The whole turnout must pass between these markers in the correct alphabetical order.

5.6. The numbers of the obstacles should be placed so that drivers can see them as they leave the previous obstacle.

## 6. Plan of the Course

6.1. At least two hours before the start of the competition for each class in the event, a plan of the course with a dotted line indicating how the length was measured, signed off by the Course Designer and the President of the Jury, must

be made available for viewing by the drivers and be posted in the Collecting Ring; this should show the length, speed in metres per minute and the Time Allowed for each class.

## **7. Inspection of the Course**

- 7.1. The Course must be open for inspection at least 2 hours before the start of the competition. A 15 minute window must be observed between the end of the inspection and the first start. Only Drivers and one accompanying person per Driver at a time are allowed to inspect the Course on foot and they must be smartly dressed. Driving aprons, hats, body protectors and gloves are not required when walking the course.
- 7.2. Drivers and trainers are not permitted to use measuring wheels when inspecting the course. Penalty: warning for first offence, yellow card from POJ for subsequent offences.
- 7.3. Only the Course Designer and their staff may alter or work on any part of the course. If any driver, or any person associated with them, alters the course in any way, the driver will be disqualified.

## 1. Single Obstacles and Open Multiple obstacles

| Class                                     | Speed<br>m/min | Cones<br>width (cm) | Zig-zag (m) | Wave (m) | Distance<br>between<br>obstacles (m) | Minimum<br>carriage width<br>(cm) |
|---|----------------|---------------------|-------------|----------|--------------------------------------|-----------------------------------|
| Horse fours                               | 240            | 185                 | 11-13       | 10/12    | 15                                   | 158                               |
| Horse tandems                             | 230            | 170                 | 11-13       | 10/12    | 15                                   | 138                               |
| Adv. horse pairs                          | 250            | 170                 | 10-12       | 8/10     | 12                                   | 148                               |
| Open horse pairs                          | 240            | 170                 | 10-12       | 8/10     | 12                                   | 148                               |
| Adv. horse single                         | 250            | 160                 | 10-12       | 8/10     | 12                                   | 138                               |
| Open horse single                         | 240            | 160                 | 10-12       | 8/10     | 12                                   | 138                               |
| Nov. horse single                         | 220            | 160                 | 10-12       | 8/10     | 12                                   | 138                               |
| Pre-Novice horse                          | 210            | 155                 | 10-12       | 8/10     | 12                                   | 125                               |
| Pony fours                                | 240            | 160                 | 9-11        | 8/10     | 12                                   | 138                               |
| Pony tandems                              | 240            | 160                 | 9-11        | 8/10     | 12                                   | 138                               |
| Adv. pony pairs                           | 250            | 160                 | 9-11        | 8/10     | 12                                   | 138                               |
| Open pony pairs                           | 240            | 160                 | 9-11        | 8/10     | 12                                   | 138                               |
| Adv. pony single                          | 260            | 160                 | 9-11        | 8/10     | 12                                   | 138                               |
| Open pony single                          | 240            | 160                 | 9-11        | 8/10     | 12                                   | 138                               |
| Nov. pony single                          | 220            | 160                 | 9-11        | 8/10     | 12                                   | 138                               |
| Pre-Novice pony                           | 210            | 155                 | 9-11        | 8/10     | 12                                   | 125                               |
| Small Equine                              | 220            | 145                 | 9-11        | 8/10     | 12                                   | 125                               |
| VSE                                       | 200            | 145                 | 9-11        | 8/10     | 12                                   | 125                               |
| Gateway                                   | 200            | 155                 | 9-11        | 8/10     | 12                                   | 125                               |
| Para / Drivers with Disabilities<br>Pony  | 230            | 160                 | 9-11        | 8/10     | 12                                   | 138                               |
| Para / Drivers with Disabilities<br>Horse | 230            | 160                 | 10-12       | 8/10     | 12                                   | 138                               |
| Children (12 - 14)                        | 220            | 160                 | 9-11        | 8/10     | 12                                   | 138                               |
| Juniors (14 - 18)                         | 240            | 160                 | 9-11        | 8/10     | 12                                   | 138                               |
| Young Drivers (16 - 25)                   | As class       |                     |             |          |                                      |                                   |

- 1.1. Measurements for Closed Multiple obstacles, see Annex 4.
- 1.2. **Cones with Reduced width:** The width of up to 5 single obstacles can be reduced by 5cm for Pairs and Four in Hand classes and up to 10 single obstacles for Single classes. Such obstacles must be marked differently (colour of cones).
- 1.3. Alternative options: A maximum of 2 single obstacles may offer an alternative single option (see Annex 7).
- 1.4. In exceptional circumstances and in the interests of safety, the Ground Jury, in consultation with the Course Designer and the Technical Delegate, may reduce the speed. Should the timing be adjusted by the Ground Jury, this will be announced.

## ARTICLE 975 JUDGING CONES COMPETITION

### 1. Starting the Competition

- 1.1. The Technical Delegate will report to the President of the Jury as soon as the course is ready. The President of the Jury will then authorise and announce the start of the competition.

### 2. Penalties

- 2.1. If drivers have entered the arena but fail to start by passing through the start line within 45 seconds of the starting signal, the timing will start.
- 2.2. If a driver fails to enter the arena when the course is ready, the President of Jury will ring the bell to signify the start for that driver. If the driver has not entered the arena within 45 seconds of the first bell, the bell will be rung again and that driver is then Eliminated.
- 2.3. Drivers starting and passing through an obstacle before the starting signal will be penalised 10 penalty points and must restart.
- 2.4. The start and finish lines are neutralised for passing through, from the moment the driver has passed through the start line until he has passed through the last obstacle.
- 2.5. Knocking down one or both balls of a single obstacle and knocking down a ball of an element of a multiple obstacle, incurs 3 penalties in each case.
- 2.6. Knocking down a ball or balls on either A or B on a Water or Bridge obstacle will incur 3 penalties for each pair of cones.
- 2.7. Grooms must remain in their proper places between the start and finish lines. Grooms must be seated for all classes except Gateway, VSE, Pre-Novice and Small Equine where they may stand. A groom can lean for balance but may not move or "jump" the carriage.
- 2.8. After the last obstacle the driver must pass through the finish line with the red flag on the right and the white flag on the left.
- 2.9. A driver may pass between the elements of an Open Multiple obstacle whilst driving between obstacles, without incurring a penalty
- 2.10. Carriage overturning is Elimination.

### 3. Error of Course

- 3.1. A driver is considered to have passed through an obstacle when the whole turnout has passed between the markers.
- 3.2. If a driver attempts to pass through an obstacle in the wrong sequence or direction, including an obstacle which has already been driven, the President of the Jury must wait until after the turnout has passed completely through the wrong obstacle before ringing the bell. The driver is then Eliminated. Gateway: no bell, the driver gets 10 penalties.
- 3.3. If a driver knocks down or dislodges any part of an obstacle which has already been driven, he will incur 3 penalties.
- 3.4. If any part of an obstacle in advance of the one being driven is dislodged or knocked down, the President of the Jury will ring the bell and stop the clock for the obstacle to be re-built. The driver will incur 3 penalties and 10 seconds will be added to their time. The bell will be rung to indicate to the driver that the course is ready and the clock will re-start when the driver reaches the next obstacle on course to continue his round.

- 3.5. If the President of the Jury sounds the whistle/bell while the driver is on the course, the driver must halt immediately. If the driver does not halt, the President of Jury will blow the whistle/bell a second time. If the driver continues without stopping, he is eliminated. The groom may advise the driver that the whistle/bell has sounded.
- 3.6. If the Jury is in doubt whether an obstacle has been properly driven, the driver must be allowed to finish the course. The Jury can then reach a decision.

#### **4. Obstacle Rebuild**

- 4.1. If the driver knocks down any part of an obstacle in the process of a disobedience or refusal, the bell will be rung and the clock stopped for the obstacle to be rebuilt and 10 seconds will be added to the driver's time, along with any penalties for disobedience (but not for the elements knocked down at the time of disobedience).
- 4.2. When the obstacle is rebuilt, the bell is rung again and the driver must then retake the complete obstacle and continue their round. The clock will re-start when the driver reaches the re-built obstacle. The penalty for starting before the bell is elimination.
- 4.3. If a driver knocks down any part of a multiple obstacle in advance of the element they are driving, or if they break out of a multiple obstacle and knocks down an element, the bell will be rung and the clock stopped while the obstacle is rebuilt, and 10 seconds added to the total time taken. The driver will be penalised for disobedience but not for the elements knocked down at the time of disobedience.

#### **5. Broken Harness**

- 5.1. If, at any time after they have started, a driver has a disconnected pole, shaft, rein, trace, pole strap or chains, or should a horse have a leg over the pole, trace, shaft or leader bars, the President of the Jury must ring the bell and stop the clock. The driver must put a groom(s) down to correct the problem and will be penalised for a groom dismounting. After the situation has been corrected and the groom has remounted, the President of the Jury will ring the bell and restart the clock.

#### **6. Drivers and Grooms Dismounting**

- 6.1. Each time a driver dismounts they will incur 20 penalties.
- 6.2. Drivers will incur penalties each time one or both grooms dismount: 5 penalties on the first occasion, 10 penalties on the second occasion and on the third occasion the driver is Eliminated. The groom(s) must be on the carriage before the next obstacle. The grooms must be on the carriage when going through each obstacle. For a groom(s) dismounting to assist through an obstacle by leading the horse by the bridle ends of the reins while the horse is still attached to the carriage, see penalties for leading and dismounting in Article 981. The groom(s) must be on the carriage before the next obstacle.

#### **7. Disobedience**

- 7.1. It is considered to be a Disobedience when:
  - 7.1.1. The driver attempts to pass through an obstacle and the horse shies away from the obstacle at the last moment without hitting any part of the obstacle.
  - 7.1.2. The horses run away, or, in the opinion of the President of the Jury, the driver has lost effective control.
  - 7.1.3. The whole turnout comes to a complete halt, with or without stepping back anywhere on the course, in front of or in an obstacle, or a multiple obstacle, with or without knocking down any element.
  - 7.1.4. Not passing through an obstacle with the whole turnout, running out of a multiple, circling within a multiple or reining back by the driver between the start and finish line.
  - 7.1.5. The turnout leaves the designated arena.
- 7.2. A disobedience will incur 5 penalties for the first, 10 penalties for the second and elimination for the third instance. Penalties for disobedience are cumulative wherever they may occur on the course.
- 7.3. If there is a disobedience in a single obstacle, i.e. the whole turnout does not pass through the markers, the driver has to retake the obstacle. The bell will only be rung if part of the obstacle is knocked down.
- 7.4. If there is a disobedience in a multiple obstacle, without knocking down any element, the driver must continue his drive and is penalised for disobedience (see paragraph 7.2 above). E.g. run-out at C without dislodging ball - driver must continue at C.
- 7.5. In the case when a disobedience is connected with knocking down an element (i.e. run-out at C and dislodging the ball) the judge rings the bell, the course is interrupted, the time is stopped and the obstacle rebuilt. The President of the Jury rings the bell again then the driver has to restart at the letter A of the multiple obstacle and the time starts when the horses nose passes gate A. For the re-building 10 extra seconds are added once.
- 7.6. If a driver has a disobedience at any obstacle and knocks down any part of that obstacle penalties will only be incurred for the disobedience and 10 seconds will be added for the rebuilding.

## **8. Resistance**

8.1. A horse is considered to offer resistance if, at any time and for whatever reason, it refuses to go forward (with or without moving back), turns around or rears. This will be penalised the same as for a disobedience.

## **9. Timing**

9.1. Each driver will be timed by stopwatch or by an electronic timing device, from the moment the nose of the leading horse crosses the start line until the nose of the leading horse crosses the finish line, but penalties are incurred until the whole turnout has passed the finish line.

9.2. Whenever possible a digital display unit should be visible for the drivers.

9.3. Times must be recorded to one hundredth of a second.

9.4. The Time Limit is twice the Time Allowed. Exceeding the Time Limit will incur elimination.

9.5. The Time Allowed is calculated using the speeds specified in article 974.1.

9.6. Penalty for exceeding the Time Allowed: any time over the Time Allowed in 1/100 seconds, multiplied by 0.5. Penalties will be calculated to 2 decimal places.

| Description  | Ref. Art. | Penalty                                    |
|--|-----------|--|
| Driver entering arena without protective headgear, jacket, gloves or apron.                                | 928       | 5 penalties                                |
| Groom entering arena without jacket, protective headgear or gloves.  | 928       | 5 penalties                                |
| Groom(s) not in position<br>First breach<br>Second breach<br>Third breach                                  | 928.1.4   | 5 Penalties<br>10 Penalties<br>Elimination |
| Driving without a driving aid in the competition   | 928.4.2   | 5 penalties                                |
| Dropping or putting down the driving aid.  | 928.4.3   | 5 penalties                                |
| No breeching with a carriage with no brakes.   | 937.1.1   | Elimination                                |
| No breeching in Singles  | 940.1.14  | Elimination                                |
| If a Groom handles the reins, brake or uses the driving aid before the Driver has crossed the finish line. | 943.2.5   | 20 penalties                               |
| Person tied to the carriage  | 943.2.6   | Elimination                                |
| Prohibited outside assistance.   | 945.2     | Elimination                                |
| Failing to start within 45 seconds of bell ring.   | 975.1.2   | Timing starts                              |
| Starting and passing through an obstacle before the bell is rung.  | 975.2     | 10 penalties and restart.                  |
| Failing to pass through start or finish lines.   | 975.2     | Elimination                                |
| For knocking down one or two balls in the same single obstacle.  | 975.2     | 3 penalties                                |
| For knocking down an element of a Multiple obstacle.   | 975.2     | 3 penalties                                |
| For driving a cone out of order or backwards, including a cone which has already been driven               | 975.3.2   | Elimination                                |
| For knocking down any part of an obstacle after it has already been driven.                                | 975.3.3   | 3 penalties                                |
| Carriage overturn  | 975.2     | Elimination                                |

|  |         |  |
|--|---------|--|
| If any part of an obstacle in advance of the one being driven is knocked down, the bell will be rung for the obstacle to be rebuilt.         | 975.3.4 | 3 penalties and add 10 seconds             |
| Taking an obstacle out of sequence.  | 975.3.2 | Elimination (Gateway 10 pen)               |
| Missing an obstacle  | 975.3.2 | Elimination                                |
| Failure to halt after the bell is rung a second time.  | 975.3.5 | Elimination                                |
| For causing an obstacle, or part of a multiple to be rebuilt.  | 975.4.1 | 3 penalties and add 10 seconds             |
| Starting before the bell after an obstacle is rebuilt.   | 975.4.2 | Elimination                                |
| Driver dismounting   | 975.6.1 | 20 penalties                               |
| Groom(s) dismounting<br>1 <sup>st</sup> incident<br>2 <sup>nd</sup> incident<br>3 <sup>rd</sup> incident                                     | 975.6   | 5 penalties<br>10 penalties<br>Elimination |
| Groom leading a Horse through an obstacle.   | 975.6.3 | 20 penalties<br>(+5 for groom dismount)    |
| Disobedience:<br>1 <sup>st</sup> incident - 5 penalties<br>2 <sup>nd</sup> incident - 10 penalties<br>3 <sup>rd</sup> incident - Elimination | 975.7   | 5 penalties<br>10 penalties<br>Elimination |
| For exceeding the Time Allowed.  | 975.9.6 | Exceeded time multiplied by 0.5            |
| Exceeding the Time Limit.  | 975.9.4 | Elimination                                |
| Grooms standing between the start and finish lines (except VSE etc)  | 975.2.7 | 5 penalties                                |

### ARTICLE 984 CONFLICTS OF INTEREST

1. No person may be an official at an event if his duties will involve a conflict of interest.
2. The following persons may not be members of a Ground Jury or an Appeal Committee at an event:
  - 2.1. Drivers and owners of horses taking part in the event:
  - 2.2. Regular trainers, employers and employees of drivers.  
**Note:** regular trainers means training a horse/driver for more than three days in the six month period before an event, or any training during a period of three months before an event.
  - 2.3. Close relatives of owners or drivers.
  - 2.4. Persons having a financial or personal interest in a horse or driver taking part in any competition.
3. A person who would not ordinarily be eligible to be a member of the Ground Jury or Appeal Committee may nonetheless be a member provided the following conditions are satisfied:
  - 3.1. The person in question does not judge Driven Dressage or Cones for any of the following classes, or have any involvement as a member of the Ground Jury in any decision concerning any Driver in such classes:
  - 3.2. any class which the person in question or their employer has entered as a driver
  - 3.3. any class in which a horse owned by the person in question is entered
  - 3.4. any class which a driver who trains regularly with the person in question or is employed by the person in question or is a close relative of the person in question has entered
  - 3.5. any class in which a driver or horse in which the person in question has a financial or personal interest is taking part.

### ARTICLE 985 ELIGIBILITY OF OFFICIALS

1. Clubs are permitted to use listed or non-listed officials for their events.
2. **For National Events**
  - 2.1. All officials on the British Carriagedriving Officials List must be at least 'Officials' members of British Carriagedriving.
  - 2.2. The British Carriagedriving Council reserve the right to re-categorise any official or remove them from the official British Carriagedriving Officials List without giving any reason. Judges, Safety Officers and Technical delegates must attend the National Clinic at least once every two years. Course Designers must attend the National Clinic at least once every three years.
  - 2.3. All Judges including specialist cones judges, Technical Delegates, Safety Officers and Course Designers must be chosen from the British Carriagedriving Officials Lists or the respective FEI lists.
  - 2.4. All officials must adhere to the Code of Conduct
  - 2.5. All officials must be named in the published Schedule of the Event.

### ARTICLE 986 JUDGES

#### 1. Appointment

- 1.1. All 3 day National Events must have at least three but not more than five judges for each class. All 2 day National events must have at least two judges for each class. A specialist Cones Judge may be used in addition. Collectively, the judges form the Ground Jury for the event.
- 1.2. The ground jury including the President of the Jury for a National Event will be appointed by the Organising Committee and approved by British Carriagedriving Council.
- 1.3. Senior Level National Judges are defined as ones with at least 5 years of experience. Probationary Judges and Judges on List 3 should only judge Novice and Open single classes.

## **2. The Duties of the Ground Jury**

- 2.1. Each member of the Ground Jury has the right and the duty to eliminate or disqualify any horse which, in their opinion, is lame or unable to continue the competition in accordance with Articles 911.7 and 935.6.1.
- 2.2. The President of the Ground Jury is responsible for the conduct and control of the entire event, in conjunction with the Technical Delegate.
- 2.3. The President of the Ground Jury will have overall control of the duties and responsibilities of the Ground Jury throughout the event.
- 2.4. In principle a judge should not judge more than 45 driven dressage tests in a day; however, this number may be increased in exceptional circumstances at the sole discretion of the President of the Ground Jury.
- 2.5. The President of the Ground Jury is responsible for the control and publication of the results of the competitions and of the event.
- 2.6. The President of the Ground Jury at a National event must complete the official report form which should be returned to the British Carriagedriving office immediately after the event.

## ARTICLE 988 TECHNICAL DELEGATE

### **1. Appointment**

- 1.1. The Technical Delegate must be selected by the Organising Committee, the appointment approved by the British Carriagedriving Council.

### **2. Duties and Responsibilities**

- 2.1. The Technical Delegate will be required:
  - 2.1.1. To approve all administrative arrangements from the time they are appointed until the end of the event.
  - 2.1.2. To satisfy themselves that the accommodation and catering arrangements for horses, drivers and grooms, and training and exercise areas, are adequate and suitable in all respects.
  - 2.1.3. To inspect the arenas and courses to ensure that the technical facilities, requirements and organisation are in accordance with the British Carriagedriving Rules and associated regulations.
  - 2.1.4. To ensure that the courses and obstacles are fair and safe.
  - 2.1.5. To instruct the Organising Committee and Course Designer to make any alterations which they consider necessary.
  - 2.1.6. To ensure that Timekeepers, Ground Observers, Obstacle Observers and Scorers are correctly instructed in their duties, including the use and reading of clocks and stop-watches.
  - 2.1.7. To report to the President of the Jury that the relevant course is ready for the start of the competition.
  - 2.1.8. To continue to supervise the technical conduct of the event, including the transfer of data to the scorers, after the President of the Ground Jury has assumed control of the event.
  - 2.1.9. To ensure the event appoints a person responsible for checking horse passports and vaccinations.
  - 2.1.10. To complete (in the case of a National event) the Report of the Technical Delegate, including names of drivers who failed to withdraw by the specified time and of horses/ponies not entered in their passport names. This should be returned to the British Carriagedriving office immediately after the event.

## ARTICLE 989 COURSE DESIGNERS

### **1. Appointment**

- 1.1. The Course Designer must be selected by the OC, and for National events the appointment approved by the British Carriagedriving Council.

### **2. Selection**

- 2.1. The Course Designer may be the same person for each competition or there may be a different Course Designer for each competition. All named course designers must be approved by the British Carriagedriving Council prior to the commencement of the event.
- 2.2 Only the Course Designer and their staff may alter or work on any part of the driven dressage arena, the marathon and cones course. Any driver, or persons associated with a driver, who tamper with any part of the arena or courses will result in the disqualification of that driver.

### **3. Duties**

- 3.1. The Course Designer is responsible, under the supervision of the Technical Delegate, for:
  - 3.1.1. Laying out and measuring the arena for Driven Dressage.
  - 3.1.2. Laying out and measuring the course and for the construction of the obstacles in the Marathon.
  - 3.1.3. Designing, laying out and measuring the Cones Course.
- 3.2. The President of the Ground Jury may only order the competition to start when the Technical Delegate has reported that the relevant course is ready.

## ARTICLE 991 VETERINARY AND MEDICAL COVER

### **1. Veterinary Cover**

- 1.1. As a minimum the Organiser must appoint an on call Equine Veterinary Surgeon to cover the duration that the Box Park is open
- 1.2. An Equine Veterinary Surgeon must be in attendance throughout the duration of Section B on marathon day at all National Events.

### **2. Medical Cover**

- 2.1. The minimum First Aid provision throughout the event should be a person with a current Emergency First Aid at Work certificate.
- 2.2. Medical cover on Marathon Day must be supplemented by a paramedic, emergency medical technician or equivalent and a casualty transport vehicle capable of operating in difficult ground conditions.

## ARTICLE 995 SAFETY AND SAFEGUARDING

### **1. Safety Officer**

- 1.1. A safety officer, appointed by the Organising Committee, will assist with the preparation of the event Risk Assessment; monitor the Implementation of the mitigating measures identified; monitor compliance with BC's Safety Rules and Guidelines and liaise with the Technical Delegate on the preparation and submission of incident and accident reports.

### **2. Safeguarding Officer**

- 2.1. A Safeguarding Officer must be appointed prior to the event to deal with safeguarding issues for the event.

## ARTICLE 996 APPEAL COMMITTEE

### **1. Composition**

- 1.1. An Appeal Committee consisting of a President and at least two other members who have a thorough knowledge of the sport must be appointed for all National events.

### **2. Meetings**

- 2.1. Appeals must be heard by all the members sitting together. The President will decide the time and place of the meeting.
- 2.2. The Committee must hear both sides of the case in appeals against decisions by individual Judges and Officials.

### **3. Decisions**

- 3.1. The decisions of the Appeal Committee are final.

### **4. Conflict of Interest**

- 4.1. See Art. 984 of these rules.

ANNEX 1      DIAGRAM OF THE 100M X 40M DRIVEN DRESSAGE ARENA

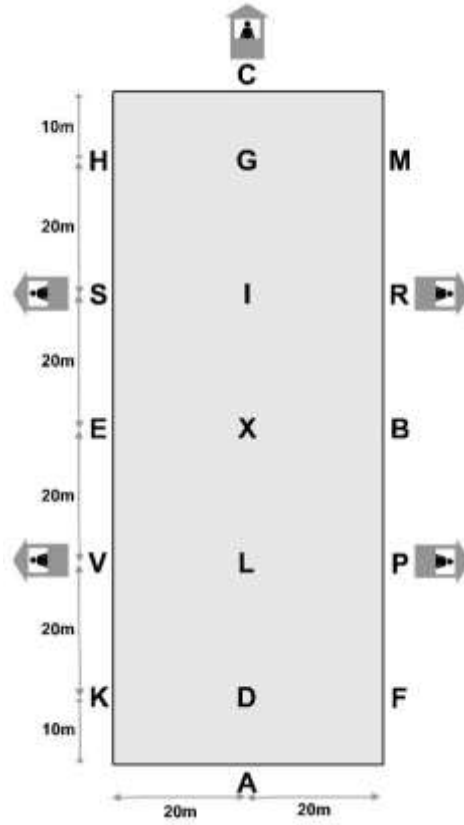
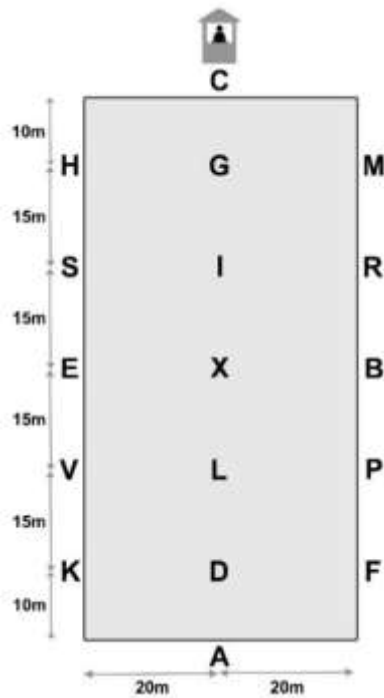

Diagram of the 80m x 40m Dressage arena



(Elements must be separated 20 cm - 40 cm)

### 1. Single "L"

Construction:

Supports – 40cm to 60cm from ground to top of rail

Elements – must be free standing; parallel or perpendicular single or sectioned rails; separated by 20cm - 40cm spacing

Markers – a pair of red and white markers, set within 15cm

Element < A > at the IN gate and << B >> at the OUT gate.

**Horse:** (minimum measurements)

|                        | IN | A1 | A2 | B1 | B2 | OUT |
|------------------------|----|----|----|----|----|-----|
| Single                 | 3  | 8  | 11 | 8  | 11 | 3   |
| Pair                   | 3  | 8  | 11 | 8  | 11 | 3   |
| Four in Hand or Tandem | 4  | 8  | 12 | 8  | 12 | 4   |

**Pony:** (minimum measurements)

|                        | IN | A1 | A2 | B1 | B2 | OUT |
|------------------------|----|----|----|----|----|-----|
| Single                 | 3  | 8  | 11 | 8  | 11 | 3   |
| Pair                   | 3  | 8  | 11 | 8  | 11 | 3   |
| Four in Hand or Tandem | 3  | 8  | 11 | 8  | 11 | 3   |

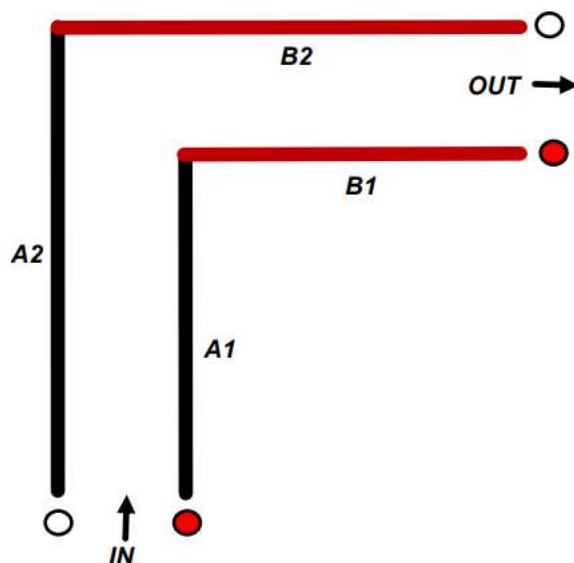

## 2. Double “L”

Construction:

Supports – 40 cm to 60 cm from ground to top of rail

Elements – must be free standing; parallel or perpendicular single or sectioned rails; separated by 20 cm-40 cm spacing.

Markers – indicating each section as follows:

A - within 15 cm of IN.

B - coloured or wrapped rails or markers on the ground.

C - within 15 cm of OUT.

**Horse:** (minimum measurements)

|                        | IN | A1 | A2 | B | B1 | B2 | C | C1 | C2 | OUT |
|------------------------|----|----|----|---|----|----|---|----|----|-----|
| Single                 | 3  | 5  | 9  | 4 | 10 | 9  | 4 | 9  | 5  | 4   |
| Pair                   | 3  | 5  | 9  | 4 | 10 | 9  | 4 | 9  | 5  | 4   |
| Four in Hand or Tandem | 4  | 5  | 10 | 5 | 10 | 9  | 5 | 10 | 5  | 5   |

**Pony:** (minimum measurements)

|                        | IN | A1 | A2 | B | B1 | B2 | C | C1 | C2 | OUT |
|------------------------|----|----|----|---|----|----|---|----|----|-----|
| Single                 | 3  | 5  | 9  | 4 | 9  | 9  | 4 | 9  | 5  | 4   |
| Pair                   | 3  | 5  | 9  | 4 | 9  | 9  | 4 | 9  | 5  | 4   |
| Four in Hand or Tandem | 3  | 5  | 9  | 4 | 9  | 9  | 4 | 9  | 5  | 4   |

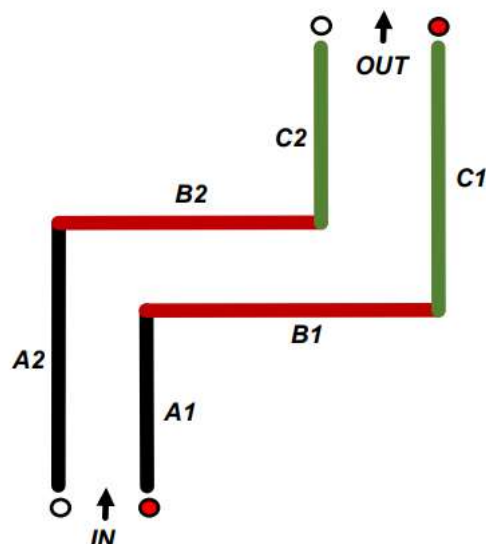

### 3. Single “U”

Construction:

Supports – 40 cm to 60 cm from ground to top of rail

Elements – must be free standing; parallel or perpendicular single or sectioned rails; separated by 20 cm-40 cm spacing

Markers – indicating each section as follows:

A - within 15 cm of IN.

B – coloured or wrapped rails or markers on the ground.

C – outside but within 15 cm of C.

**Horse:** (minimum measurements)

|                        | IN | A1 | B | B1 | B2 | C1 | OUT |
|------------------------|----|----|---|----|----|----|-----|
| Single                 | 3  | 9  | 4 | 5  | 7  | 9  | 4   |
| Pair                   | 3  | 9  | 4 | 5  | 7  | 9  | 4   |
| Four in Hand or Tandem | 4  | 9  | 5 | 5  | 9  | 10 | 5   |

**Pony:** (minimum measurements)

|                        | IN | A1 | B | B1 | B2 | C1 | OUT |
|------------------------|----|----|---|----|----|----|-----|
| Single                 | 2  | 8  | 3 | 5  | 5  | 8  | 3   |
| Pair                   | 3  | 9  | 4 | 5  | 7  | 9  | 4   |
| Four in Hand or Tandem | 3  | 9  | 4 | 5  | 7  | 9  | 4   |

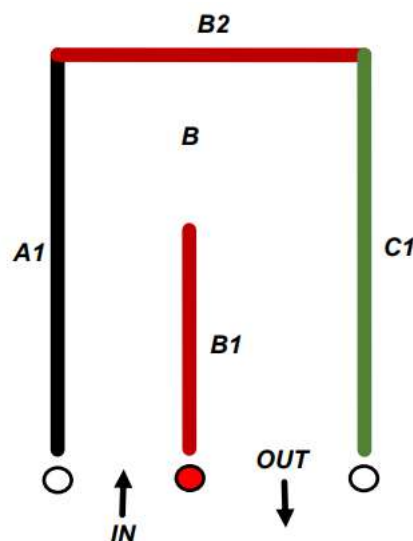

#### 4. Double "U"

Construction:

Supports – 40 cm to 60 cm from ground to top of rail

Elements – must be free standing; parallel or perpendicular single or sectioned rails; separated by 20 cm-40 cm spacing

Markers – indicating each section as follows:

A- within 15 cm of IN.

B, C – coloured or wrapped rails or markers on the ground.

D – within 15 cm of OUT.

**Horse:** (minimum measurements)

|                        | IN | A1 | B | B1 | B2 | C | C1 | C2 | D1 | OUT |
|------------------------|----|----|---|----|----|---|----|----|----|-----|
| Single                 | 3  | 12 | 4 | 8  | 7  | 4 | 8  | 8  | 12 | 4   |
| Pair                   | 3  | 12 | 4 | 8  | 7  | 4 | 8  | 8  | 12 | 4   |
| Four in Hand or Tandem | 4  | 13 | 5 | 8  | 9  | 5 | 8  | 10 | 13 | 5   |

**Pony:** (minimum measurements)

|                        | IN | A1 | B | B1 | B2 | C | C1 | C2 | D1 | OUT |
|------------------------|----|----|---|----|----|---|----|----|----|-----|
| Single                 | 2  | 9  | 3 | 6  | 5  | 3 | 6  | 6  | 9  | 3   |
| Pair                   | 3  | 12 | 4 | 8  | 7  | 4 | 8  | 8  | 12 | 4   |
| Four in Hand or Tandem | 3  | 12 | 4 | 8  | 7  | 4 | 8  | 8  | 12 | 4   |

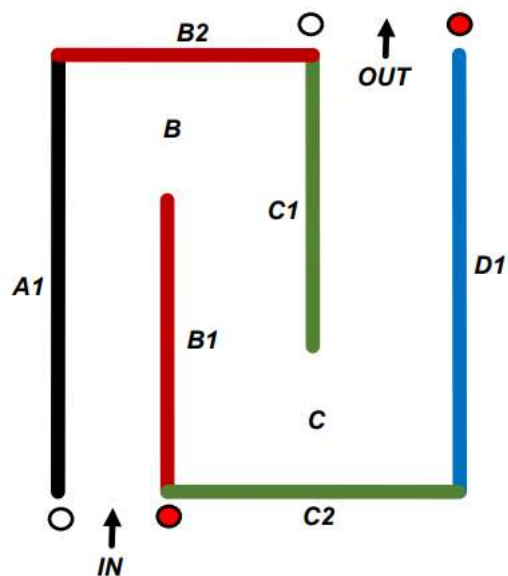

## 5. Box

Construction:

Supports – 40 cm to 60 cm from ground to top of rail

Elements – must be free standing; parallel or perpendicular single or sectioned rails; separated by 20 cm - 40 cm spacing

Markers – indicating each section as follows:

A- within 15 cm of IN.

B – coloured or wrapped rails or markers on the ground.

C – outside but within 15 cm of C.

**Horse:** (minimum measurements)

|                        | IN | A1 | A2 | B | B1 | B2 | C1 | C2 | OUT |
|------------------------|----|----|----|---|----|----|----|----|-----|
| Single                 | 3  | 4  | 8  | 4 | 7  | 8  | 4  | 7  | 4   |
| Pair                   | 3  | 4  | 8  | 4 | 7  | 8  | 4  | 7  | 4   |
| Four-in-Hand or Tandem | 4  | 5  | 9  | 5 | 8  | 10 | 5  | 8  | 5   |

**Pony:** (minimum measurements)

|                        | IN | A1 | A2 | B | B1 | B2 | C1 | C2 | OUT |
|------------------------|----|----|----|---|----|----|----|----|-----|
| Single                 | 2  | 3  | 7  | 3 | 6  | 6  | 3  | 6  | 3   |
| Pair                   | 3  | 4  | 8  | 4 | 7  | 8  | 4  | 7  | 4   |
| Four-in-Hand or Tandem | 3  | 4  | 8  | 4 | 7  | 8  | 4  | 7  | 4   |

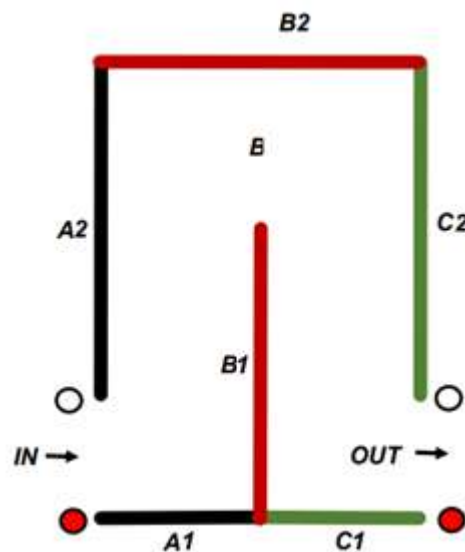

## 6. Double Box

Construction:

Supports – 40 cm to 60 cm from ground to top of rail

Elements – must be free standing; parallel or perpendicular single or sectioned rails; separated by 20 cm-40 cm spacing

Markers – indicating each section as follows:

A- within 15 cm of IN.

B, C – coloured or wrapped rails or markers on the ground.

D – within 15 cm of OUT.

**Horse:** (minimum measurements)

|         | IN | A1 | A2 | B | B1 | B2 | C | C1 | C2 | D1 | D2 | OUT |
|---------|----|----|----|---|----|----|---|----|----|----|----|-----|
| Singles | 3  | 4  | 8  | 4 | 7  | 8  | 4 | 7  | 8  | 7  | 4  | 4   |
| Pairs   | 3  | 4  | 8  | 4 | 7  | 8  | 4 | 7  | 8  | 7  | 4  | 4   |
| Tandems | 4  | 5  | 9  | 5 | 8  | 10 | 5 | 8  | 10 | 8  | 5  | 5   |
| Fours   | 4  | 5  | 9  | 5 | 8  | 10 | 5 | 8  | 10 | 8  | 5  | 5   |

**Pony:** (minimum measurements)

|         | IN | A1 | A2 | B | B1 | B2 | C | C1 | C2 | D1 | D2 | OUT |
|---------|----|----|----|---|----|----|---|----|----|----|----|-----|
| Singles | 2  | 3  | 8  | 3 | 7  | 6  | 3 | 7  | 6  | 7  | 3  | 3   |
| Pairs   | 3  | 4  | 8  | 4 | 7  | 8  | 4 | 7  | 8  | 7  | 4  | 4   |
| Tandems | 3  | 4  | 8  | 4 | 7  | 8  | 4 | 7  | 8  | 7  | 4  | 4   |
| Fours   | 3  | 4  | 8  | 4 | 7  | 8  | 4 | 7  | 8  | 7  | 4  | 4   |

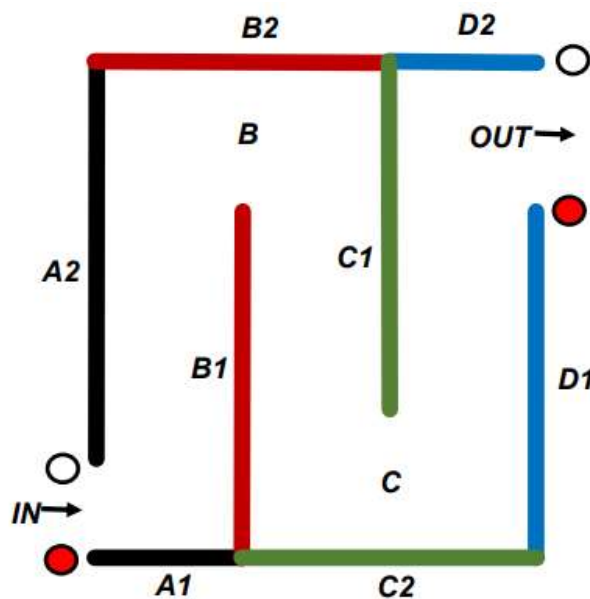

1. ZIG-ZAG:

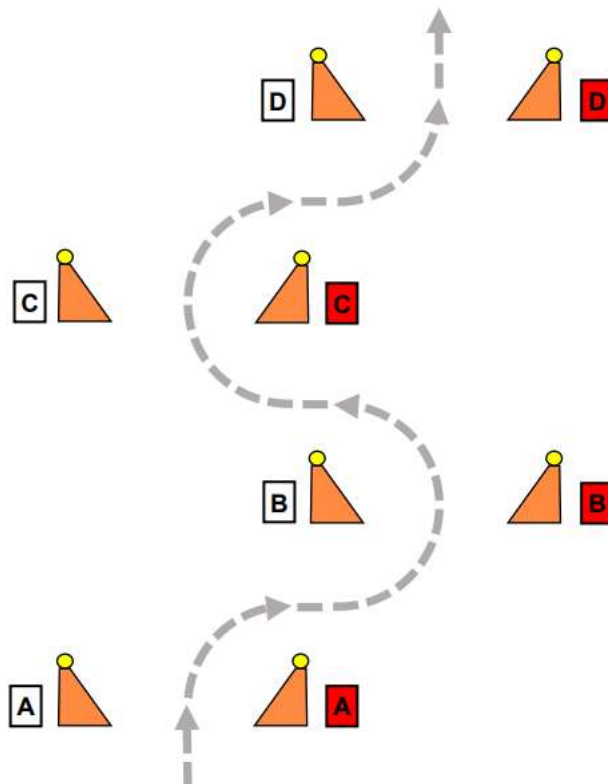

Distance between pairs of cones, centre to centre

|              | Horses | Ponies |
|--------------|--------|--------|
| Four-in-Hand | 13m    | 11m    |
| Tandem       | 13m    | 11m    |
| Pair         | 12m    | 11m    |
| Single       | 12m    | 11m    |

Centre line cones to be set in a straight line, either in front, at the middle or at the rear of the cone (as shown above) with markers placed within 15 cm.

The centre line cone shall not be adjusted, the outside cone shall be set to the required track width.

## 2. THE WAVE:

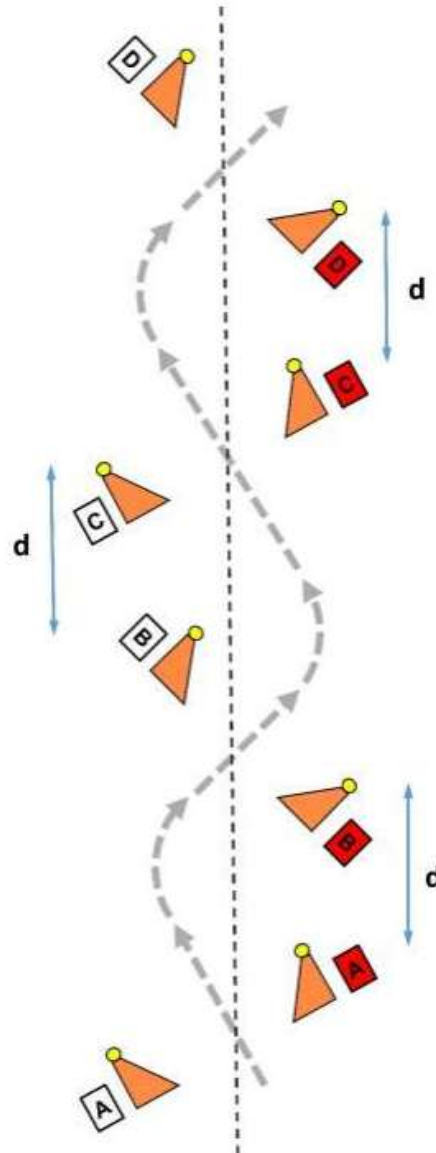

Angle of pair of cones to the middle wave line - approximately 45 degrees.

**d = distance between nearest pair of cones - centre to centre**

|              | Horses | Ponies |
|--------------|--------|--------|
| Four-In-Hand | 10-12m | 10-12m |
| Tandems      | 10-12m | 10-12m |
| Pairs        | 8-10m  | 8-10m  |
| Singles      | 8-10m  | 8-10m  |



## 6. Alternative to ZIG-ZAG

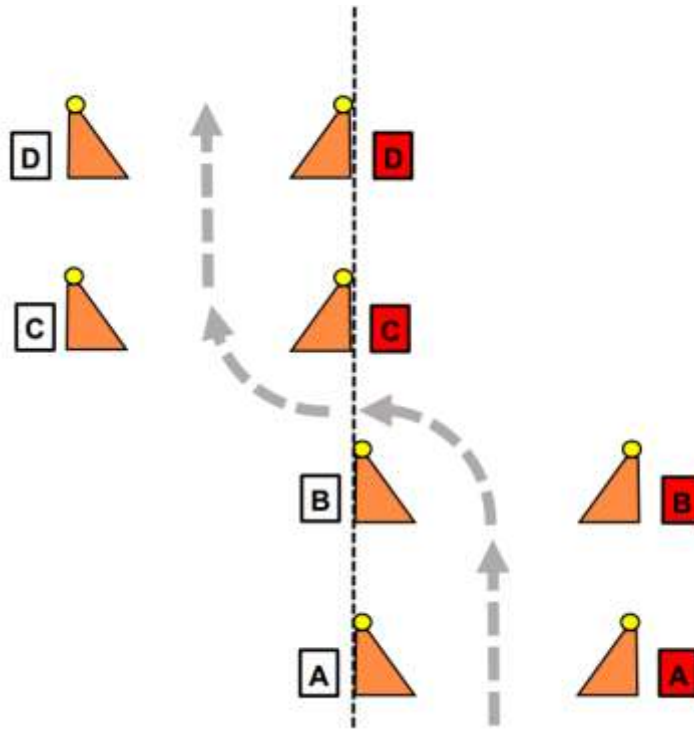

## 7. Alternative to ZIG-ZAG

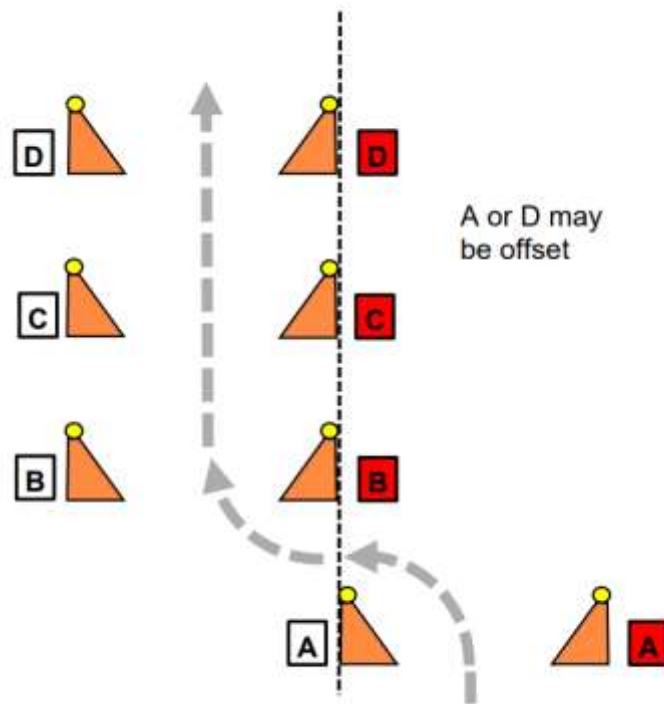

## 8. The Triangle

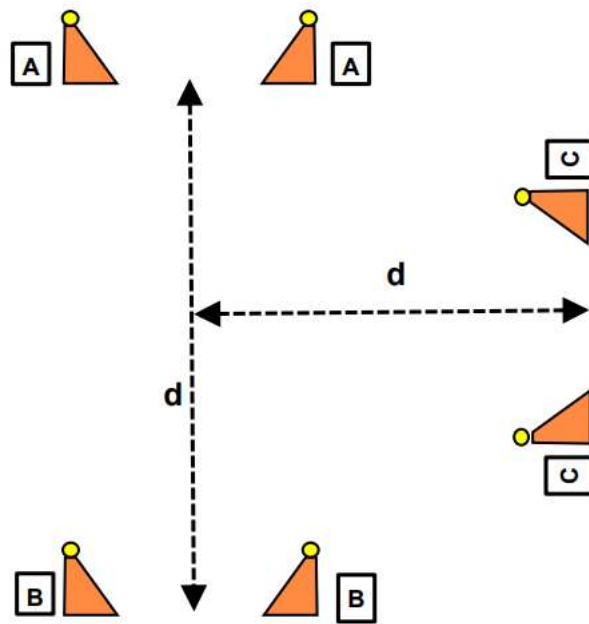

Distance between cones (d)

|              |        |
|--------------|--------|
| Four-in-hand | 10-12m |
| Tandem       | 10-12m |
| Pair         | 8-10m  |
| Single       | 8-10m  |

Example flagging

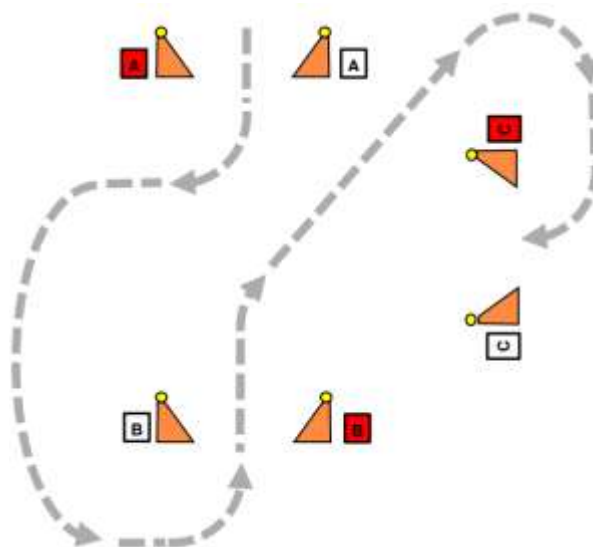

**Dimensions:**

10m x 3m; maximum 20 cm high with fan shaped wings

Cones required at both ends adjacent to bridge, with red and white letters A at entrance and letters B at exit, set at a constant clearance of 2.0 metres for all classes.

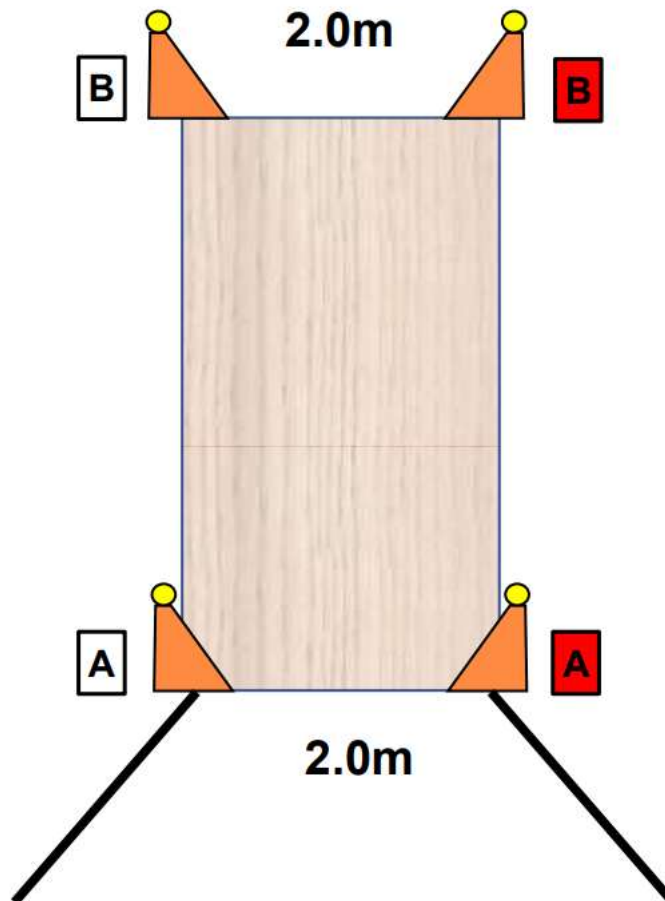

Alternative routes

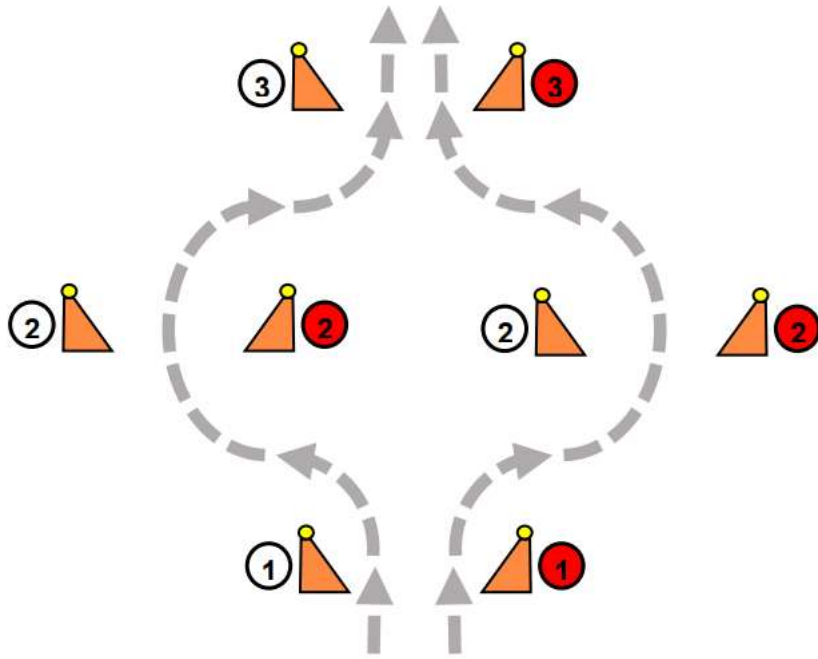

Official distance = the longest route

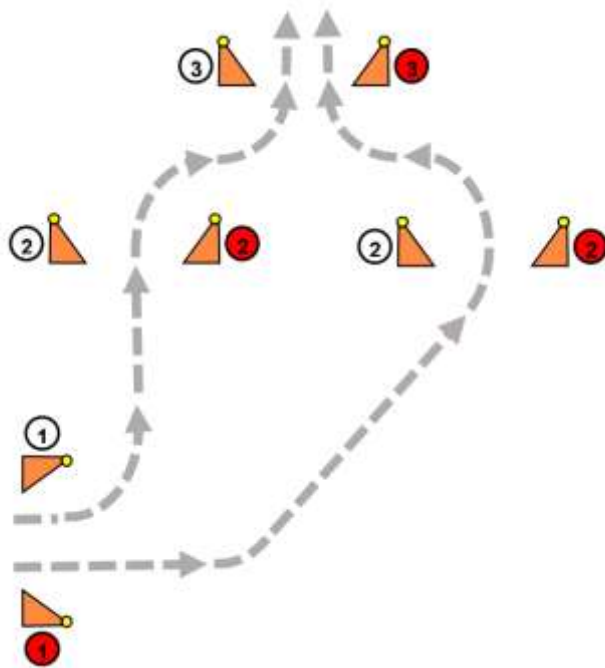

An oxer will be composed of 2 pairs of cones in a straight line.

The distance between the first set of cones and the second set will be between 1.5 and 3 metres, at the option of the Course Designer.

The oxer counts as a single obstacle and the maximum penalty points for knocking down up to 4 balls is 3 penalty points in total.

The first set of cones will have the number of the obstacle and be marked with red and white flags and the second set of cones will be marked with red and white flags.

This obstacle will be judged as a single obstacle. The oxer may be crossed

A maximum of five oxers are allowed in a cones course.

Distance between the two pair of cones: minimum 1.5, maximum 3 metres.

The distance between the two pairs of cones has to be measured from the Balls

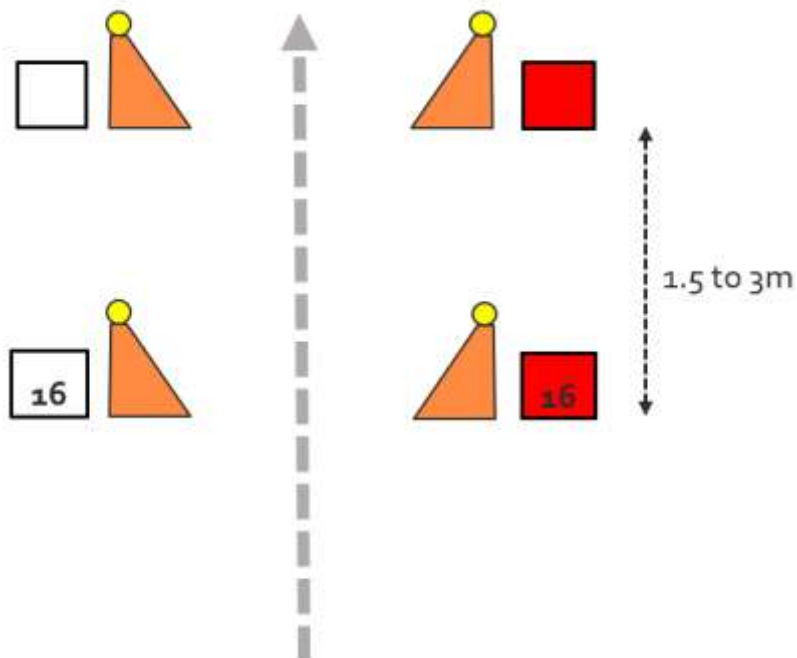

## 1. Affiliation

1.1. Requests to hold National Horse Driving Trials must be made in writing to British Carriagedriving. In the case of new applications the Council will arrange for the site and facilities to be inspected and the organisation approved before affiliation is agreed. Once the date and classes are agreed upon, the appointment of the Technical Delegate, President of the Jury, Safeguarding Lead and Safety Officer have been approved, and the event has been included in the British Carriagedriving fixture list, these may not be altered without permission of the Council. The British Carriagedriving Office will supply event organisers with the necessary paperwork for their event and a list of equipment available, if required.

## 2. Start Fees

2.1. National event organisers will be responsible for collecting Start Fees from all drivers at the rate to be published by the British Carriagedriving Council in December each year for use in the following year. The fees collected must be remitted to the British Carriagedriving office within ten days following any National event. Start Fees for other events are remitted as Affiliation requires.

## 3. Schedules

3.1. The organiser should publish a schedule of competitions not less than six weeks before the event. Schedules need not repeat the rules contained in the Rule Book but should include:

- Classes and competitions to be held
- Conditions of entries
- Approximate timetable
- Names of Dressage Tests and size of arenas
- Marathon sections included
- Time at which Marathon papers are available and course is open for inspection
- Disclaimer of Liability, Organiser's Reservation of Right,
- Brief instructions how to reach the place of competition including What3Words access code to site.
- Health & Safety Clause

## 4. Programme

4.1. Any programmes must include the following:

- Statement that the event is held under British Carriagedriving rules
- Classes and timetables of competitions
- List of entries
- List of Officials, including Organiser, Technical Delegate, Ground Jury, Appeals Committee, Course Builder, Veterinary and Medical Officer, Farrier and Safety Officer.
- Disclaimer of Liability
- Reservation of Right
- Health & Safety Clause

4.2. The following should be included if possible:

- Brief Rules and system of scoring
- Plan of the Marathon Course however simple
- Sketches of Marathon Obstacles
- Plan of Obstacle Driving Course
- Requests that dogs should be kept on leads

## 5. Disclaimer of Liability

5.1. The following disclaimer must be printed on all schedules, entry forms and programmes:

- "Neither the Organising Committee of any Horse Driving Trials to which these Rules apply, nor British Carriagedriving, nor any land owner, nor any agent, employee or representative of these bodies, save for the death or personal injury caused by the negligence of the Organisers or anyone for whom they are in law responsible, accepts any liability for any damage, injury or illness to horses, owners, drivers, grooms, spectators, land or any other person or property whatsoever, whether caused by negligence, breach of contract or in any other way whatsoever".

## **6. Reservations of Rights**

6.1. The organiser has the right to:

- Cancel the class or event without giving reason
- Divide or combine any class (subject to the drivers being informed and given the chance to withdraw or change classes)
- Alter the advertised times
- Refuse entry, with or without stating the reason

## **7. Health and Safety**

7.1. The following statement on Health and Safety must be printed verbatim on all schedules, entry forms and programmes:

- “The organiser of this event has taken reasonable precautions to ensure the health and safety of everyone present. For these measures to be effective everyone must take all reasonable precautions to avoid and prevent accidents occurring and must obey the instructions of the organisers and all officials and stewards.”

7.2. Detailed guidelines of Health and Safety are published on the web-site [www.britishcarriagedriving.co.uk](http://www.britishcarriagedriving.co.uk)

## 1. Passports

- 1.1. All horses and ponies must have a recognised, statutory passport and unique identification number (UELN) in compliance with Government regulations.
- 1.2. On entering an event the equine information must be completed on line.
- 1.3. **Vaccinations** for equine influenza must be given in accordance with the following provisions:
  - 1.3.1. All proprietary equine influenza vaccines are accepted, provided the route of administration complies with the manufacturer's instructions (i.e. intramuscular injection or intranasal).
  - 1.3.2. An initial Primary Course of two vaccinations must be given; the second vaccination must be administered within 21-60 days of the first vaccination.

Transitional Provision: Horses whose first vaccination (V1) of the primary course is recorded in the passport and dated before 1 January 2024 shall be deemed compliant with the previous requirements and are not required to restart the primary course, provided that the second vaccination (V2) was administered within 21-92 days of V1 and all subsequent booster vaccinations have been administered within the intervals required by these rules.
  - 1.3.3. The first booster must be administered within 7 calendar months following the date of administration of the second vaccination of the Primary Course.
  - 1.3.4. Booster vaccinations must be administered at a maximum of 12 month intervals, the same day in each year being acceptable for these purposes. If this period is exceeded, the vaccination course must be restarted as above.
  - 1.3.5. Horses competing in events must have received a booster within 6 months +21 days (and not within 7 days) before arrival at the event.
  - 1.3.6. Horses may compete 7 days after receiving the second vaccination of the primary course.
  - 1.3.7. Horses that have received the Primary Course prior to 1 January 2005 are not required to fulfil the requirement for the first booster, providing there has not been an interval of more than 12 months between each of their subsequent annual booster vaccinations.
  - 1.3.8. Horses/ponies must be entered at all Affiliated Events and Shows in their registered names. Spot checks of identification, passport and vaccinations of horses/ponies will be carried out on the first day of the competition at all events on 10% of starters.

## 2. Penalties.

- 2.1. The following penalties will be imposed if any passports or vaccinations are not in order:
  - 2.1.1. If the driver is not in possession of statutory passports for all his horses on arrival at the event, he /she will not be allowed to compete. If a driver is found to have competed with a horse without being in possession of a passport, a fine of £50.00 will be imposed, and the animals will not be allowed to compete in a National Event until the fine has been paid.
  - 2.1.2. If the passport is not correct or, if the record of vaccinations is incorrect, these will be referred to a Veterinary Surgeon and, if confirmed to be out of order, the driver will be fined £50.00 but may be allowed to compete at the discretion of the President of the Jury. The identification document/passport must be in order and the fine paid before being allowed to compete again.
  - 2.1.3. Horses and ponies not entered in the names shown on their passports will be allowed to continue to compete, but will be fined £20.00.

**1. Lodging a Query, Objection or Appeal**

1.1. Only the owner, or his authorised agent, or the driver driving the horse taking part in the competition is entitled to lodge a query, objection or an appeal.

**1.2. Query and Objection**

1.2.1. A query must be put to the Secretary within half an hour of the posting of the scores. The Secretary will take up the query or complaint with the scorers, Technical Delegate or the President of the Jury and, if it is justified, a correction will be made.

1.2.2. An objection must be made in writing to the Secretary of the Event/Show not later than 30 minutes after the posting of the scores. In the case of objections to the course or to the qualification of a driver these must be made not later than one hour before the start of the Marathon.

**1.3. Appeal**

1.3.1. If the driver is not satisfied with the decision of the Ground Jury they may lodge an appeal in writing with the Secretary's Office within 30 minutes of the posting of the scores accompanied by a deposit of £50.00.

1.3.2. The Secretary will take the objections to the Technical Delegate or President of the Jury and if necessary, the Appeal Committee (where applicable) whose decision will be final. If the appeal is rejected, the deposit is forfeited, unless the Appeal Committee decides that there had been reasonable grounds for the objection at the time, in which case it may decide to refund all or part of the deposit.

1.3.2.1. An appeal may be brought against the finding of the Appeal Committee in one or more of the following circumstances:

1.3.2.1.1. evidence has become available to the driver which could not with reasonable diligence have been made available at the hearing.

1.3.2.1.2. the decision was not one which could reasonably have been made by the Appeal Committee, or that it failed to take into account matters which it ought to have done or that it took into account matters which it ought not to have done; or the penalty imposed was too severe.

**1.3.3. Appeal Procedure**

1.3.3.1. The appeal must be brought by giving written notice specifying the grounds of the appeal to the BC within three working days of notification of the Appeal Committee's decision and must be accompanied by a deposit of the sum of £100.00. The amount of any fine imposed must also have been paid. These sums may be refunded dependent upon the outcome of the appeal;

1.3.3.2. An appeal will be heard by the Disciplinary Committee of British Equestrian.

1. Unless indicated otherwise, all events are run under the current British Carriagedriving Rules.
2. It is **COMPULSORY** for suitable properly secured hard hats to be worn by anyone on a carriage being driven, or **RIDING** horses/ponies at any event. See Annex 17.
3. It is essential that dogs must be kept on short leads **at all times**, and drivers are responsible for ensuring that their dogs do not cause a nuisance. Penalties at the discretion of the Event Organiser will be imposed. Dogs must not be tied to or led from carriages when exercising or competing.
4. Horses/ponies may not be tethered at events. Event Organisers may, at their discretion, permit horses or ponies to be kept in an uncovered pen provided a suitable risk assessment is carried out. Details of what form and size of uncovered pen is permitted will be published in the event schedule.
5. Drivers are responsible for providing their own number holders and bibs.
6. The use of any type of ATVs, scooters, mopeds, motorised vehicles and motorbikes at events is at the discretion of individual organisers. All motorised vehicles and bicycles must only carry the number of people for which they are designed and must not be operated by children. The guidance in the British Carriagedriving Safety Policy Statement must be followed and it is strongly recommended that suitable and properly secured hard hats should be worn. Any motorised vehicle driven on a public highway at an event must be road legal and have valid third party liability insurance.
7. No horsebox or caravan will be allowed on to an event site unless it is fitted with a suitable, in-date fire extinguisher of 3kg minimum. Anybody without this may be refused access. The fire extinguisher should be placed on the near side of the main vehicle in each camp, near the entrance to the living area.
8. Only members of the British team and the nominated individual who have competed at a FEI World or Continental Championship are entitled to wear the Union Jack badge with plain background on their jackets. In addition, any driver who finishes first, second or third in the final individual classification at a CAIO is subsequently entitled to wear the badge. They are entitled to wear the badge in perpetuity.

**1. Membership**

- 1.1. Drivers must be International, Full or Young members of British Carriagedriving appropriate to the level of event entered.
- 1.2. Drivers competing in Gateway Classes may compete as a member of a BC affiliated club. If a driver qualifies for and wishes to compete at the National championships they may do so, using Affiliated Club Memberships, for their first season only.
- 1.3. Making an entry for any affiliated Horse Driving Trials Event/Show constitutes acceptance of the British Carriagedriving rules.

**2. Further Conditions**

- 2.1. The Council reserve the right to downgrade any driver whose driving, in their opinion, is not up to standard.
- 2.2. The Technical Delegate or President of the Jury may at any time exclude from the competition any driver who, in their opinion, is injured or unfit, for instance as a result of a fall.
- 2.3. If a presiding Judge at the Driven Dressage test considers that a turnout is unsafe, they will advise the driver on completion of the test and before the driver leaves the arena, that a report will be submitted to the President of the Jury.
- 2.4. The President of the Jury will then discuss the case with the Ground Jury. They will advise the driver of the outcome of this discussion, and if the driver is then allowed to go on the Marathon, the President of the Jury will ensure that they are closely monitored and may be asked to retire at any time that the driver or their horse are considered a danger.
- 2.5. **There is no appeal against the decision of the President of the Jury.**

**3. Backsteppers/Grooms**

- 3.1. It is the responsibility of the driver to ensure that their groom or grooms are fit and capable of rendering speedy and efficacious assistance at any time.
- 3.2. The Technical Delegate, the President of the Jury or the official Doctor may at any time stop a driver whose groom in their opinion appears unfit or incapable of assisting and ask them to demonstrate that they can carry out their duties as described above.

**4. Driver Qualifications**

- 4.1. The eligibility to compete in a class refers to the driver, unless stated otherwise.
- 4.2. Before entering their first event the driver must complete an Introductory Safety and Competence Assessment and forward a copy of this to the organiser.
- 4.3. A completed competence card must be submitted before a driver enters their first national event (Prenovice, Novice, VSE or SE) or progresses to national pair, tandem or four in hand classes. Drivers must successfully complete all three phases at two affiliated club events over a period of not more than 3 years. The Competence Form must be signed by the Club/Event Secretary to acknowledge completion, and by the Driven Dressage Judge and the Technical Delegate to signify their approval of the driver's ability to enter a National class. Competence forms must be submitted for signature at each event to which they relate prior to the driver starting the event. Drivers who have completed all three phases of the Indoor Carriage Driving National Championships during the current or previous two seasons need only complete one further affiliated club event, provided the ICD Championship Event Organiser signs their competence card. A driver may have their card signed for any completion of a Prenovice, Novice, VSE or SE class, or a mix of class completions, to compete at national level in any of these classes. E.g. a card completed for club events with a Novice Pony is acceptable for entry to national Prenovice, Novice, VSE or SE class
- 4.4. An organiser may waive the requirement for a competence card at their discretion if they feel there are not sufficient events in the region for a driver to get a competence card signed and they feel the driver is competent.

**1. Overview**

- 1.1. In Gateway classes, drivers and backsteppers/grooms may wear appropriate marathon clothing for all competitions.
- 1.2. It is intended that these classes will be run at National and club events, at a time to suit the event, but preferably (in the case of National events) on Saturday or Sunday. They may also be run by an affiliated club as a stand alone event. There will be a National Championship qualification from these classes.
- 1.3. Gateway classes can be run at National and Approved Affiliated Club Events. Gateway drivers can compete at all events – Club or National (including the National Championships) - using Affiliated Club membership.
- 1.4. Ages of Drivers and backsteppers can be found in Chapter IV – Article 912.
- 1.5. Any person under 18 must wear a hard hat and a body protector at all times while on the carriage. All persons on a carriage must wear a properly secured hard hat throughout all three competition phases and a body -protector during the obstacle phase. Drivers with Disabilities / Para Drivers can use Compensating Aids.
- 1.6. Gateway is open to Singles and Pairs only.
- 1.7. The BC Gateway are competitions in 3 parts: Dressage, Cones and Obstacles (with no marathon).
- 1.8. The appropriate driven dressage test for each class is listed on the BC Website
- 1.9. BC Gateway events can be run as stand-alone events, on the same day as a one day event, or as part of a two or three day event.
- 1.10. Carriage width throughout the competition is 125cm
- 1.11. Grooms may sit or stand in the dressage and cones phases. If standing, they can lean for balance (in cones) but must not jump or move the carriage at all.
- 1.12. Competitors must adhere to British Carriagedriving Rules regarding carrying a driving aid.

**2. GENERAL GUIDELINES**

- 2.1. Competitors should be allowed time to walk obstacles either before their competition starts or after dressage and cones. If this class is part of a 2 or 3 day event, then allowance must be made on marathon start times to accommodate this.
- 2.2. Safety checks must be performed on all turnouts before each phase of the competition.
- 2.3. HC drivers can be accepted at events and will not be eligible for the BC National Championships.
- 2.4. Some penalties are different from other competitions - no eliminations at this level. See below.

**3. Class Progression**

- 3.1. Gateway Newcomers is open to anyone who has never competed at Intermediate level or above at any National, or Affiliated Club event.
- 3.2. Gateway Allcomers is open to all other levels.
- 3.3. Newcomer winners at the Gateway Championship must move into the Allcomers class the following season. Any other newcomer driver competing at the National Championships may choose to stay in the Newcomer class for a second year.
- 3.4. All Newcomers can only contest at that level for 2 consecutive years then they move to Allcomers.
- 3.5. Allcomers winners at the National Championships will only be permitted to attend the Gateway Championships in subsequent years as a HC entry.

**4. BC Gateway Newcomers**

- 4.1. There can be a maximum of 2 classes in Newcomers – Horse and Pony. Pairs are permitted within the classes, tandems and teams are not allowed.
- 4.2. An Introductory Safety and Competence Assessment must have been completed on the turnout and only that assessed turnout can take part. A safety check must be completed on entries prior to starting the Dressage Phase and Obstacle Phase.
- 4.3. Entries can be accepted from any driver providing they have not competed at Intermediate level or above in any BC Affiliated Club event, or at Novice or above at any BC National event.
- 4.4. Drivers must have passed their 6<sup>th</sup> birthday and have passed a safety assessment carried out by a BC approved assessor before entering. Dual reins are permitted.

**5. BC Gateway Allcomers**

- 5.1. There can be a maximum of 2 classes in Allcomers - Horse and Pony. Pairs are permitted. Tandems and teams are not allowed.
- 5.2. An assessment may need to be completed on the turnout if deemed appropriate by the Organiser.

## **6. Dressage**

### **6.1. Newcomers.**

- 6.1.1. Test: Gateway Newcomers
- 6.1.2. Judged on rhythm, suppleness and contact.
- 6.1.3. This phase takes place in an arena measuring anywhere between 40m x 20m and 80m x 40m. The arena size is at the discretion of the Organising Committee.
- 6.1.4. At least one judge at or near C. If other judges, they will be on the side at E or B
- 6.1.5. 10 movements including walk, trot and halt.
- 6.1.6. The groom may call the test to the driver

### **6.2. Allcomers**

- 6.2.1. Test: Gateway Allcomers
- 6.2.2. Judged as BC main Rule Book and Dressage Test listing.
- 6.2.3. A circle will always be the size specified in the test even if a smaller than 80m x 40m arena is used.
- 6.2.4. All movements will start and end as prescribed in the test, i.e. horse's nose on the marker or driver on centre line

## **7. Cones Newcomers & Allcomers**

- 7.1. Between 10 and 15 pairs of cones
- 7.2. Maximum two difficulties (zig zag, cloverleaf, etc) allowed.
- 7.3. No bridge or water allowed.
- 7.4. Width set at 155 cm.
- 7.5. Time allowed based on 200m per min.

## **8. Penalties**

- 8.1. Knockdown - 3 penalties
- 8.2. Wrong direction or wrong order - 10 penalties
- 8.3. Miss a pair of cones - 20 penalties
- 8.4. Not completed in time allowed will incur penalties at 0.5 penalties per second over the allowed time.
- 8.5. Vehicle narrower than 125cm - additional 3 penalties

## **9. Obstacles**

- 9.1. Obstacles which can be:
  - 9.1.1. 1 obstacle driven 4 times, or
  - 9.1.2. 2 obstacles driven twice, or
  - 9.1.3. 4 obstacles driven once each.
- 9.2. Gates will be flagged A to D or E
- 9.3. Obstacles may be either permanent or temporary (light or heavy) and can be located indoors or outdoors. Water obstacles and bridges are not permitted.
- 9.4. The course may include traditional indoor-style obstacles or incorporate sections of the marathon route. However, if using part of the marathon course, it must be clear that this is not intended to be a shortened marathon. A maximum section time may be set when marathon elements are used, keeping in mind that smaller equines will naturally move more slowly. No time penalties should be applied based on speed.

## **10. Penalties**

- 10.1. Drive gates in wrong order or wrong direction - 10 penalties each occurrence
- 10.2. Miss a gate - 20 penalties
- 10.3. Time taken in obstacle - 0.25 penalties per second.
- 10.4. The driver with the lowest total penalties shall be the winner.
- 10.5. If two drivers have the same score, the driver with the best score for dressage shall be the winner.
- 10.6. If two drivers still have the same score, the driver with the best score for obstacle driving shall be the winner.
- 10.7. If two drivers still have the same score, both will receive a winner's rosette.

11. The winner of each class will qualify for the National Championships. Qualification will pass down the line if the winner has already qualified (to 3rd place).
12. If the competition is held at a club competition it is the qualified driver's responsibility to notify the BC office that they have qualified, on what date and at which competition. Email notification to email@britishcarriagedriving.co.uk

### 13. GATEWAY - SUMMARY OF PENALTIES

| Phase     | Description                                   | Penalty   |
|-----------|---|---|
| Cones     | Knockdown                                     | 3 penalties                                     |
|           | Wrong direction or wrong order                | 10 penalties                                    |
|           | Miss a pair of cones                          | 20 penalties                                    |
|           | Not completed in time allowed                 | 0.5 penalties per second over the allowed time. |
|           | Vehicle narrower than 125cm                   | 3 penalties                                     |
| Obstacles | Drive gates in wrong order or wrong direction | 10 penalties each occurrence                    |
|           | Miss a gate                                   | 20 penalties                                    |
|           | Time taken in obstacle                        | 0.25 penalties per second.                      |

---

#### PRE NOVICE

1. Before they enter their first national event, drivers must submit a completed competence card (Driver Qualification, 4 above)
2. Drivers who have competed at a higher level may compete in this class with a novice animal, but must be classed as HC.
3. Results in these classes do not affect levels in any other class.

---

#### VSE (VERY SMALL EQUINES)

1. Before they enter their first national event, drivers must submit a completed competence card (Driver Qualification, 4 above)
2. A driver, when first entering the class, may drive the Novice A or Novice B dressage test (except drivers who have previously competed at Intermediate who must drive Novice B).
3. A driver who chooses to drive Novice A may move to Novice B whenever they choose to do so. If a driver chooses to drive Novice B test, they will not be permitted to drive Novice A at any further events or at the National Championships. Drivers MUST move to Novice B at the end of the season if they win the class on two occasions.
4. Results in these classes do not affect levels in any other class.

---

## SMALL EQUINES

1. Before they enter their first national event, drivers must submit a completed competence card (Driver Qualification, 4 above)
2. A driver, when first entering the class, may drive the Novice A or Novice B dressage test (except drivers who have previously competed at Intermediate who must drive Novice B).
3. A driver who chooses to drive Novice A may move to Novice B whenever they choose to do so. If a driver chooses to drive Novice B test, they will not be permitted to drive Novice A at any further events or at the National Championships. Drivers MUST move to Novice B at the end of the season if they win the Small Equine class on two occasions.
4. Results in these classes do not affect levels in any other class.

---

## NATIONAL NOVICE SINGLE CLASSES

1. To be run at National Events.
2. To be eligible to compete in a National Novice Single Class, a driver must:
  - 2.1. submit a completed competence card (Driver Qualification, 4 above) or have previously competed in a National Novice class.
  - 2.2. or choose to move back to or stay at Novice if eligible to drive at Intermediate in 2023.
3. A driver, when first entering the Novice class, may drive the Novice A or Novice B dressage test (except drivers who have previously competed at Intermediate who must drive Novice B).
4. A driver who chooses to drive Novice A may move to Novice B whenever they choose to do so. If a driver chooses to drive Novice B test, they will not be permitted to drive Novice A at any further events or at the National Championships. Drivers MUST move to Novice B at the end of the season if they win the Novice class on two occasions.
5. The driver must not have:
  - 5.1. competed in a higher class at a National Event (other than an Intermediate class), or
  - 5.2. finished in first place at the National Novice Championship, or
  - 5.3. won a National Novice class, in which 3 or more drivers started the Event, on two occasions (although the Novice status is retained until the end of the season. The driver may move to Open in that season if they wish but if they qualify at Open level for the National Championships the Open class will be the one contested there).
6. A driver who has completed the Novice class without elimination, driving Novice B on at least 2 occasions with a best dressage mark of 65 or less may choose to move to the Open class.
7. The driver's first National event can be contested using a 'free' upgrade to membership from Affiliated Club membership.
8. Any subsequent events will require full BC membership.
9. A driver from the Advanced or Open Classes may compete in the Novice Singles Class with a Novice Horse. They must return to the Open Class at the end of the season in which they win their first event and will not be eligible to qualify for the National Novice Championship. A Novice Horse is one that has never competed in an Open or Advanced Singles Class.

---

## OPEN SINGLES CLASSES

1. To be eligible to compete in the Open Singles class, a driver must have:
  - 1.1. Previously competed in a National Open Class, or
  - 1.2. been eligible to drive at Intermediate in 2023, or
  - 1.3. opted to move to Open under 5 or 6 above or
  - 1.4. won the National Novice championship
2. A driver from the Advanced or Open Classes may compete in the Novice Singles Class with a Novice Horse. They must return to the Open Class at the end of the season in which they win their first event and will not be eligible to qualify for the National Novice Championship. A Novice Horse is one that has never competed in an Open or Advanced Singles Class
3. A driver, when entering the Open class, may drive the Open A or Open B dressage test

4. A driver who chooses to drive Open A may move to Open B whenever they choose to do so. If a driver chooses to drive Open B test, they will not be permitted to drive Open A at any further events or at the National Championships. Drivers MUST move to Open B at the end of the season when they win the Open class on two occasions.

---

## ADVANCED SINGLES CLASSES

1. The eligibility to compete in the Advanced Singles class refers to the driver.
2. A driver may progress to the Advanced Class after they have completed two Open classes, driving the Open B dressage test, at National Events without elimination, disqualification or retirement with a dressage score of 65 or less at one of these events.
3. Drivers from the Advanced Singles Class may return voluntarily to the Open Singles Class, dressage test Open B, at any time.

---

## PAIR CLASSES

1. To be eligible to compete in a Pair Class, a driver must have completed the marathon, without retirement, disqualification or elimination with a single in a minimum of two Open or Advanced classes at National Events or with a pair at a minimum of two Affiliated Club Events. A driver qualifying at Club Events must submit a copy of their completed competence form. The driver will be asked to present their turnout for a safety inspection before the Driven Dressage at their first National Event with the pair, at a time specified.

---

## ADVANCED CLASSES

1. Drivers who have previously competed at FEI 3\* level or above in any class may progress directly to the Advanced class.

---

## TANDEM CLASSES

1. To be eligible to compete in a Tandem Class, a driver must have completed the Marathon without retirement, disqualification or elimination with a single in a minimum of two Open or Advanced classes at National Events, or with a Pair or Tandem at a minimum of two Affiliated Club Events. A driver qualifying at Club Events must submit a copy of their completed Competence Form. The driver will be asked to present their turnout for a safety inspection before the Driven Dressage at their first National Event with the Tandem, at a time specified.

---

## FOUR IN HAND CLASSES

1. To be eligible to compete in a Four in Hand Class, a driver must either (1) have completed 2 affiliated club events without elimination, retirement or disqualification (to be demonstrated by the submission of a fully completed Competence Form) and have completed 2 National Events in any Open or Advanced Class without elimination, retirement or disqualification or (2) have completed the Marathon without elimination, disqualification or retirement with a, pair or tandem at a minimum of two National events. They will be asked to present their turnout for a safety and competence inspection before dressage at his/her first National event with a team, at a time specified by the organiser.

---

## YOUNG DRIVERS

1. **Applicability**
  - 1.1. All Young Drivers competing at National events must comply with the rules set out elsewhere in these rules.
  - 1.2. A driver's or groom's age is treated for the whole year as the age they become at their birthday in the calendar year.
  - 1.3. The rules apply (in addition to those set out elsewhere in these rules) at British Carriagedriving training events for Young Drivers and at British Young Drivers' competitions and at National Events. They are recommended to affiliated clubs who may adopt them for young driver classes or any classes in which young drivers are permitted to drive.
  - 1.4. Drivers remain eligible to attend British Carriagedriving training events for Young Drivers and British Young Drivers' competitions up to the age of 25.
2. **Eligibility**

- 2.1. Every driver attending a British Young Driver's training camp or competition for the first time must be assessed for competence and safety, with the horse to be driven, before being allowed to compete.
  - 2.2. Drivers between the ages of 6 and 10 (inclusive) may, after assessment, be required to drive a vehicle with the groom seated alongside holding a second set of reins.
  - 2.3. An assessment can be carried out only by a person approved by British Carriagedriving.
  3. **Grooms**
    - 3.1. Drivers of 6 - 12 years of age must have a competent groom aged 21 years or over when competing.
    - 3.2. In all cases in which the turnout is in danger, the groom of a turnout driven by a driver aged 18 years or less must take appropriate steps to assist the driver to regain control including, particularly, in cases where a second set of reins is in use, taking up the reins. No penalties will be incurred as a result of action taken under this rule.
    - 3.3. It is the responsibility of the groom to monitor the welfare of both the driver and the horse.
  4. **Vehicles and Equipment**
    - 4.1. The vehicle must fit the driver. The driver must be able to brace themselves between a solid footrest and the back of the seat.
    - 4.2. Everyone, grooms, drivers and passengers, must wear securely fastened protective headgear at all times when on the carriage including during training and exercising.
    - 4.3. Any driver under the age of 18 must wear a body protector at all times when on the carriage. Anyone on the carriage on the marathon must wear a body protector.
  5. **Insurance**
    - 5.1. All drivers attending British Carriagedriving training events for young drivers or British Young Drivers' competitions must have third party liability insurance. For drivers over 6 years of age this can be by membership of British Carriagedriving or by independent insurance.
  6. **Special Arrangements**
    - 6.1. Event organisers may make specific modifications to the rules set out elsewhere in these rules to accommodate young drivers. By way of example drivers in the 6 – 12 age group may be allowed to drive a vehicle of 125 cm track width in all three phases. Any such modifications, and details of the age groups to which they apply, must be published in the event schedule.
- 

## DRIVERS WITH DISABILITIES

1. **Policies are on BC website**
- 

## NATIONAL CHAMPIONSHIPS AND POINTS LEAGUES

1. **Eligibility**
  - 1.1 To be eligible to drive at the National Championships or to be included in the Driver of the Year Awards, the driver must be an International or Full member of British Carriagedriving. (Excluding Gateway)
2. **Qualification for the National Championships**
  - 2.1 Qualification for the National Championships refers to the driver. A driver may qualify for more than one class providing they have been placed in a qualifying position in that class and must nominate which class or classes they intend to contest at the time of entry for the National Championships.
  - 2.2 A driver may only compete once in each class.
  - 2.3 If a driver qualifies in more than one level of Singles or Pairs with the same Horse(s) or ponies they must nominate the higher level class.
  - 2.4 If a driver qualifies with two different turnouts they will be permitted to enter with both, provided this can be accommodated within the schedule on the day without the driver running out of class order/sequence.
  - 2.5 If a driver qualifies in a class and also competes without qualifying for the National Championships in a higher class during the season, they may still compete at the National Championships in the class in which they qualified.
3. **Qualifying Classes for the National Championships**
  - 3.1 In order to qualify, a driver must be a Full or Young member (depending on the class entered). They must complete all three phases of the competition without elimination or retirement.
  - 3.2 Any National competition which takes place during or after the National Championships will count as a qualifying event for the following year's National Championships.
  - 3.3 Qualification Criteria for Classes for the National Championships

| <b>Number of drivers in the class</b> | <b>Qualification Criteria</b>   |
|---------------------------------------|---|
| 5 or more                             | The highest two disregarding those already qualified from the first eight places. |
| 1 to 4                                | The highest placed disregarding those already qualified.                          |
| In addition                           | Any driver who has completed two National events in the same class.               |

3.4 Qualifying Classes            Pre-Novice & Novice Singles, VSE and Gateway

Venue    - British Carriagedriving approved Affiliated Club Events and National Events

3.5 Qualifying Classes            Open Singles and Pairs, Advanced Singles and Pairs, Tandems and Fours

Venue    - National Events.

---

## INTERNATIONAL

### 2. Progression to International Competition

- 2.1. Before entering their first international event at 2\* level or above, drivers must be eligible to enter the advanced class for their class. A driver may only enter an international event driving a turnout which they are eligible to drive at a National event.
- 2.2. Child, Junior and Young Driver entry to FEI events is at the discretion of the Youth Chef D'Equipe and the International Chef Committee.

### 3. CODE OF CONDUCT FOR BRITISH EQUESTRIAN TEAM DRIVERS

- 3.1. Drivers, backsteppers and all accompanying personnel should treat all participants with respect, dignity and equality within the context of the sport.
- 3.2. Drivers, backsteppers and all accompanying personnel should develop a respectful working relationship with Chef/ Coaches/Vet/Physio and other personnel working alongside all prospective team members at all times.
- 3.3. Drivers should display high standards of presentation of themselves and their animal/s ensuring that the welfare of the animal is priority. The driver should also ensure that all accompanying personnel follow the same high standards especially when wearing the Team Brand.
- 3.4. Drivers should ensure that all verbal interaction (and that of their accompanying personnel) is acceptable and polite and cannot be interpreted by others as abusive bullying, inappropriate or threatening or could bring the team or our sport into disrepute.
- 3.5. Drivers (and all accompanying personnel) should be familiar with BC Safeguarding policy.
- 3.6. Drivers must be aware that it is their responsibility to ensure that all accompanying personnel adhere to BC Code of Conduct. They must behave with dignity and respect to everyone including all Event workforce, other drivers and their support team, Coaches, Chef, assistants, judges and officials.
- 3.7. Any failure of the driver or their accompanying support team to comply to the provisions of the Code of conduct (either verbally or through actions) they may render the DRIVER liable to disciplinary procedure and /or removal from the team.

- 1.1. Everyone on the carriage must always wear a protective hat to the standards specified below.  
 British Carriagedriving aligns its hat standards with those of other British Equestrian (BEF) Member Bodies.

Only hats to the following specifications are recommended at any British Carriagedriving or British Carriagedriving Affiliated Club event. These standards are planned to be mandatory from May 2027.

| Hat Standard  | Safety Mark  |
|---|--|
| Snell E2016 & 2021 with the official Snell label and number |    |
| PAS 015: 2011 with BSI Kitemark or Inspec IC Mark           |    |
| (BS) EN 1384:2023 with BSI Kitemark or Inspec IC Mark       |   |
| VG1 with BSI Kitemark or Inspec IC Mark                     |  |
| ASTM-F1163 2015 & 2023 with the SEI mark                    |  |
| AS/NZS 3838, 2006 with SAI Global Mark                      |  |

Note: some hats are dual-badged with different standards. If a hat contains at least one compliant hat standard it is deemed suitable for competition, even if it is additionally labelled with an older standard.

- 1.2. It is recommended that no recording device is affixed to the hat.
- 1.3. The fit of the hat and the adjustment of the harness are as crucial as the quality. Members are advised to try several makes to find the best fit. The hat should not move on the head when the head is tipped forward. British Carriagedriving recommends you visit a qualified BETA (British Equestrian Trade Association) fitter.
- 1.4. Hats must be replaced after a severe impact as subsequent protection will be significantly reduced. Hats deteriorate with age and should be replaced after three to five years depending on the amount of use.
- 1.5. Hats must be worn at all times when driving with the chinstrap fastened and adjusted so as to prevent movement of the hat in the event of an impact.
- 1.6. The Official Steward/Organiser may, at their discretion, eliminate a driver driving in the area of the competition without a hat or with the chinstrap unfastened or with a hat that does not comply with these standards.
- 1.7. British Carriagedriving strongly discourages purchasing second-hand riding hats or buying them from online retailers without a professional fitting in person.
- 1.8. It is considered to be the responsibility of the driver to ensure that their hat complies with the required standards before they start any British Carriagedriving National or Affiliated Club event. Also, they are responsible for ensuring that the manufacturer's guidelines with regard to fit and replacement are followed.

# HOWDEN



The Howden Equine team  
are pleased to support the

# Novice Driver of the Year Awards

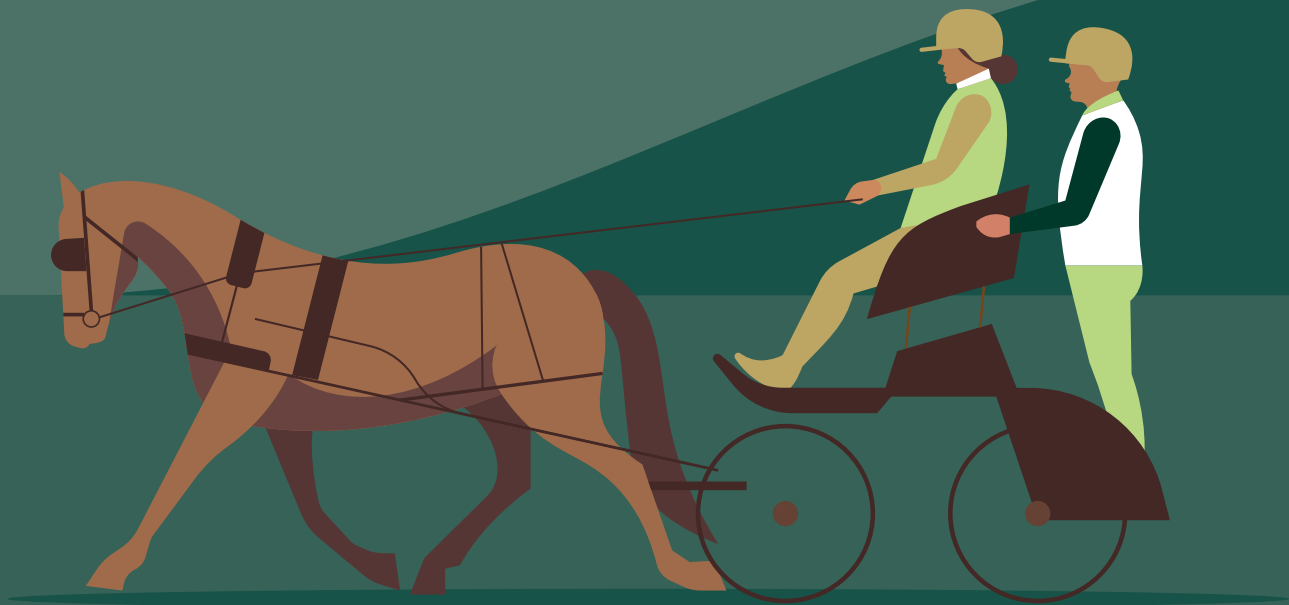

## Contact us

+44 (0)20 3857 7950  
info.equine@howdengroup.com

[howdengroup.com/equine](http://howdengroup.com/equine)

Our equine insurance experts have many years experience designing bespoke products for equestrian market.

Please contact us to discuss your insurance requirements for any equestrian business or equestrian related personal insurances.



Howden Insurance Brokers Limited is authorised and regulated by the Financial Conduct Authority No. 309639. Registered in England and Wales under company registration number 00725875. Registered Office: One Creechurch Place, London, EC3A 5AF. Calls may be monitored and recorded for quality assurance purposes. 02/26 Ref: 14380-3