



Barossa Bushgardens

Place Plants People



BIRDS OF THE BAROSSA

We are taking to the skies. When we leave our houses in the morning, when we go to the park, even in sheds on our farms we can find them, birds. They seem to be everywhere and each species has perfectly adapted to the environment they live in.

Changes in the environment have displaced some species and are threatening even more. In this edition we introduce you to some local bird species found in the Barossa, but also introduced pest birds and what options there are to limit their impact.

Bird habitat ranges from the ground up to the sky. In this case there is no right or wrong plant because each bird species is adapted to a certain growth level, like ground-level plants, shrub layer, low growing trees and tall trees, but also the variety of plant. Is it grasses that sustain finches, nectar producing plants for honey eating birds, or other shrubs that are an important habitat for insect eating birds like wrens.

Blue Wrens in the Bushgardens

At the Barossa Bushgardens, we have been trying unsuccessfully to attract Blue Fairy Wrens and thanks to a visit from Phil Barron, from Barron Environmental, we now seem to know why and hopefully have a few ideas what to do about it.

It doesn't seem to be the plants that we have planted in the past, although we should add more shrubs that are not or not as much nectar producing, like Acacias and Bursaria. No, our main problem are Noisy Minors. They are native but very territorial and can even kill smaller birds. It seems we still have to work on getting the balance right as they don't have many predators, at least not near the Bushgardens, and are supported by the plantings in the surrounding home gardens (a lot of them nectar producing plants).

Wrens don't travel far and need daily water supply. There is no surface water in summer, except to bird baths that are shared by all the different species visiting the gardens. This means that little birds probably miss out on a drink.

We are working on a solution to have potentially more drinking spots for birds and the future bio-retention basin near the nursery might be a blessing.

Until then, we keep putting up bird boxes (manual on how to build a bird box attached) and add more plants to the gardens.

If you would like to learn more about birds, join our Bird ID Workshop on the Barossa Bushgardens Open Day and Regional Landcare Forum on the 16th May, run by Phil Barron.

THE ROLE OF LOCAL BIRDS

The birds below are all local to the Barossa and each one represents an entire suite of birds with different habitat needs and different food sources in order to survive.

If a bird's particular habitat needs are too fragmented or missing, local extinctions will follow. Read below about each bird to learn about its special role and niche in the environment.

White-plumed Honeyeater

Honeyeaters do two critically important things for the environment: they pollinate many flowering plants and they vacuum clean our gums of harmful insects.

Being nectar feeders, they need low, dense, prickly shrubs such as Eremophilas, Tea-trees and Grevilleas in order to feed and nest, as well as gum trees. Honeyeaters also feed on insects and control pests such as lerps and other sap-sucking insects which contribute to tree die-back. They are the vacuum cleaners of the bush!



Photo: White-plumed Honeyeater; Source: John Gitsham, Birds SA



Pardalote

Pardalotes are brilliantly coloured birds, smaller than sparrows, only 13 grams of sheer leaf-pecking energy! Their main diet is lerps and other sap-sucking insects which infest gum leaves. Their piercing call is often heard in the treetops, before they are seen. Pardalotes nest in tree hollows or in tunnels built in sandy banks.

Photo: Pardalote; Source: Birds SA

Blue Wren

Wrens and fantails are examples of insect-eating birds. Wrens require low, dense shrubs (such as *Acacia paradoxa*) in order to nest and hide from predators. Wrens live their entire lives in the same patch and are unable to fly long distances.



Photo: Blue Fairy Wren; Source: Trevor Cox, Birds SA

THE ROLE OF LOCAL BIRDS

Wedge-tail Eagle

There are possibly only a few pairs of wedge-tail eagle remaining in the Barossa. Birds of prey such as eagles are at the top of the food chain and eat rabbits, birds and lizards larger than 500grams and rarely kill lambs. Their main food source is carrion.

Having a nesting platform in large trees or on very tall buildings/chimneys can help attract birds of prey, that in turn help with the control of pest birds and 'overpowering' species numbers of Noisy Minors.



Photo: Wedge-tail Eagle; Source: Brian Blaycock, Birds SA



© Kevin Williams

Photo: Red-browed Finch; Source: Kevin Williams, Birds SA

Finch

Finches are declining in numbers locally, because of lack of habitat. Finches feed on grass seeds, and whilst they will also eat weed seeds, the problem is that weed seeds are not available over the entire year. Finches tend to be very sociable and live in flocks. Like most birds, they require water on a daily basis.

HOW TO BUILD A BIRD BOX

Nest Box Tips

- Use untreated wood. Animals may chew it and chemicals can harm them
- Arrange timber so that growth rings radiate away from the centre of the box. Subsequent “warping” will force the box together rather than apart
- The box should have drainage holes in the bottom and ventilation holes toward the top but not in the roof, or water will leak in
- Place the entrance hole near the top so that the bottom remains dark
- Add “toe holds” inside the box so young can climb out
- The lid of your box must slope from the back of the box to the entrance with an overhang of at least 25 mm. Use hinges so you can clean it out after breeding season
- Choose your position carefully. The best place for your box is in a sheltered location, so think about which side of your house takes the brunt of cold wind and driving rain. Position your box at least 3 m above the ground
- If you attach your nest box to a tree, use wire that is covered with a piece of garden hose to protect the tree from damage
- Choose a spot with a branch on the opposite side of the tree to rest the wire on
- Cover the bottom of the box with wood shavings or shredded bark
- Keep an eye on your nest box and make sure that pest species haven’t moved in. If you find that is the case, empty the box and close the entrance hole for a while
- Put your new nest box up in late winter or early spring. This is the time that early breeders like rosellas are looking for a place to raise their young

Please Note: The width and depth (C+B) in the drawing below, is the Internal Diameter in the table on the next page and height (A) is the same as depth/length.

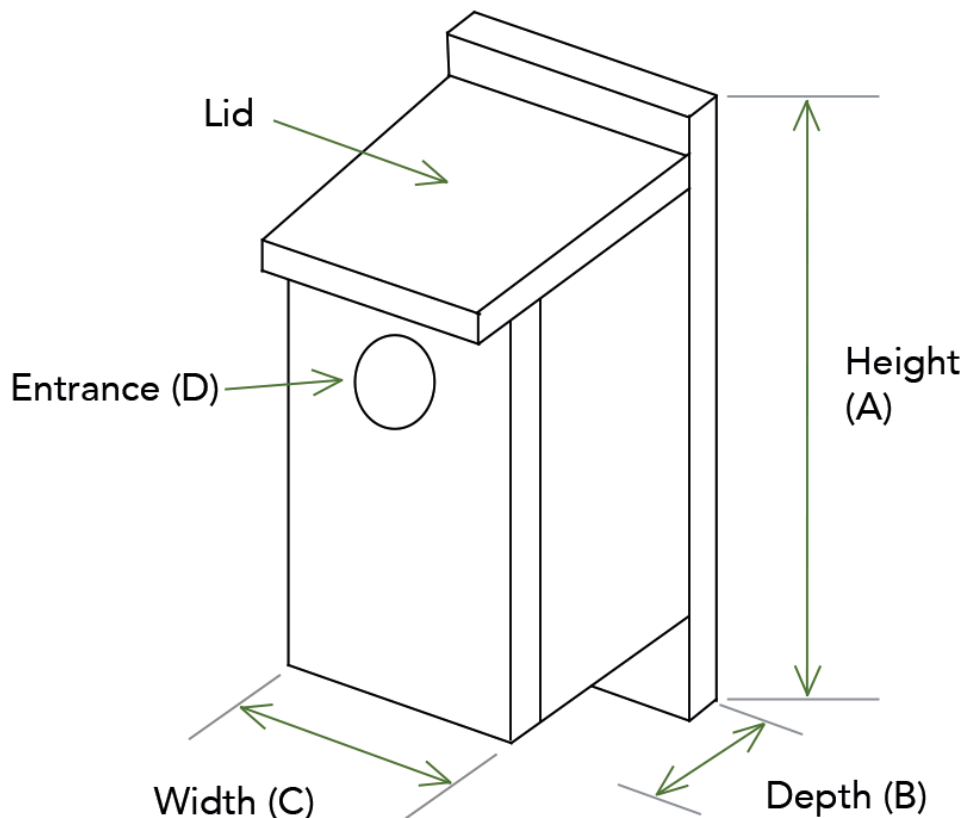

HOW TO BUILD A BIRD BOX

Different birds like different nest boxes

Real estate is rare and depending on what bird you want to accommodate, the bird box should be suitable for them. The entrance hole should be just big enough for the residents to get in. You can also add a stick under the entrance hole to help buddies on their way in and out of the box, if you like.

Species	Internal Diameter (mm)	Depth/length (mm)	Entrance Diameter (mm)	Vertical/Horizontal	Height in tree (m)
Black-Cockatoo, Glossy	300	870-1000	160x200	V	
Boobook, southern			150	h	
Cockatoo, Sulphur-crested			150	V	
Corella, Little			150		
Corella, Long-billed			150		
Duck, Australian Wood	200	500	120	V	
Galah	450x300		120	h	6
Kestrel, Nankeen	400	750	100	V	5
Kingfisher, Sacred	130	600-900	75	h	5-10
Kookaburra, Laughing	300-400x150-200	500-600	Open, >130	h	5-10
Lorikeet sp.	120	600	60	h	5
Lorikeet, Little, Musked, Purple-crowned			25-30		
Owl, Eastern Barn	400	750	Open, >150	h	5
Owlet-nightjar, Australian	100-150	300-400	30-120	V	5
Pardalote sp.	120	400-500	30-45	h	5
Pardalote, Striated	90-200x120-150	200	25-35	v/h	
Parrot, Red-rumped	100-240	400-600	25-120	v/h	5

HOW TO BUILD A BIRD BOX

Different birds like different nest boxes

Species	Internal Diameter (mm)	Depth/length (mm)	Entrance Diameter (mm)	Vertical/Horizontal	Height in tree (m)
Rosella sp.	120-200	350-800	70-120	v/h	5
Rosella, Crimson	150-200	350-800	75-100	v/h	5-6
Rosella, Eastern	135-240	350-800	60-1—	v/h	5-6
Shrike-thrush, Grey	150-200x200-300	150-300	Open,>150	h	
Swallow, Welcome	130		Open	h	3
Teal, Chestnut	200-400x300	450-750	80-120	V	1.5
Teal, Grey	200-450x300	450-750	80-120	V	1.5
Treecreeper sp.	90-150	100-400	50-80	V	5
Treecreeper, White-throated	75-100	300-400	50-70	V	5



INTRODUCED BIRDS

Invasive birds can be problematic for wildlife, agriculture and even human health, but many birders don't understand exactly what an invasive bird species is. By knowing how a species can be classified as invasive, better wildlife control measures can be taken to protect native birds.

Introduced birds

Introduced birds in Australia are those species that have been transported to an area in which they do not normally occur. These do not include summer migrants to our shores and inland waters, as these have been regular visitors over a long period of time but do not make Australia their permanent home. However, they do include Australian species that have been introduced to places in Australia where they did not previously occur, e.g. Rainbow Lorikeets in Perth.

How Introduction Happens

There are several ways that a non-native bird species can "invade" different regions, both naturally and with human assistance.

- **Geographic Expansion:** Birds that rapidly expand their ranges and crowd out resident species may be considered invasive, particularly if the expansion is damaging to other species or ecosystems or if there is an artificial reason behind the range shift, such as habitat loss.
- **Deliberate Import:** Some bird species have been deliberately imported to new areas for various reasons. This happened in North America with the house sparrow when European settlers wished to introduce familiar birds from their homelands to their new country, without regard for the long-term consequences. Other bird species may be deliberately imported in attempts to control insect populations or for other well-meaning purposes with disastrous consequences.
- **Escape:** Species popular as pets may regularly escape confinement or be released from unscrupulous retailers and subsequently establish wild populations. Other bird species may escape from farms or contained breeding grounds and grow populations in the wild that can impact resident birds.
- **Accidental Import:** Some bird species may be inadvertently introduced to new areas through accidental imports. This can happen when a bird stows away on a plane or ship and escapes in a distant region, though many times the birds are not able to establish a wild population because of a lack of breeding partners.

Problems

Invasive birds can cause a wide range of problems, not only for native species but also for the ecosystem altogether. Common problems with invasive birds include:

- Competition for nesting sites
- Competition for food sources
- Consumption of agricultural crops
- Transmission of diseases
- Disruption of ecological predator/prey balance

In the case of invasive birds, these negative effects outweigh the potentially positive gains from new species, such as biological diversity and the aesthetics of enjoying new birds.

into sandstone and other building materials - and spreading parasites such as bird mites (e.g. Common Starling, Rock Dove/Feral Pigeon). Other species have not managed to penetrate far beyond their original release sites and remain only in limited urban areas (e.g. the European Song Thrush, which is confined to Melbourne and Geelong).

How can we discourage them?

- **Plant for native birds:** most introduced birds thrive in association with lawns and buildings, so reducing lawn area by planting native trees and shrubs makes your property less attractive to introduced species (and more attractive to native species).
- **Reduce exotic, berry-producing plants:** these often attract exotic birds such as Common Blackbirds.
- **Secure roof spaces,** thereby reducing potential nest or roost sites: for birds such as Common Starlings and Common Mynas that like to use cavities.
- **Other control measures** include poison, trapping and hunting but should not be attempted by unqualified individuals.

Some Introduced birds include:

- Common Blackbird
- Common Myna
- Common Starling
- House Sparrow
- Laughing Dove
- Rock Dove
- Spotted Dove

LAYERED BIRD LIST FOR THE BAROSSA

At this point, we would usually have a list of plants from our Community Nursery that attracts birds, but every plant attracts a suite of birds. As described previously, Finches love grasses, insect-eating birds are attracted by shrubs that don't produce so much nectar, whereas for honeyeaters the opposite is the case.

Chris Hall, who is the Environmental Education Officer at The Barossa Council, has had a long love for local birds and the way they live. In 2011 he compiled a list of bird species local to the Barossa and split them up into the different layers they are usually found in. This should help with the selection of what to plant and we are happy to give advice.

Generally seen in the air:

Wedge-tailed Eagle

Nankeen Kestrel

Black-faced Cuckoo Shrike [still reasonably common up here, often seen on the wing]

Welcome Swallow

In the trees:

Laughing Kookaburra

Red Wattlebird

Little Wattlebird

White-plumed Honeyeater [tends to be more in the trees than the shrub layer]

Rainbow Lorikeet

Adelaide Rosella

Crimson Rosella

Musk lorikeet

Little Corella

Sulphur-crested Cockatoo

Pardalotes

Grey Shrike-thrush

Southern Boobook

Tawny Frogmouth

Starling

Thornbills

In the shrub layer:

New Holland Honeyeater [I have included him in the shrub layer rather than the tree layer, they are often found very low down seeking nectar etc]

Noisy Miner

Silvereye

Superb Fairy Wren/blue wren

Eastern Spinebill

On the ground:

Willie Wagtail

Crested Pigeon

Galah

Common Bronzewing Pigeon

Red-rumped Parrot

Magpie

Magpie lark/Murray magpie

Sparrow

Blackbird

Finches

Quail

In the water:

Pacific Black Duck

Wood Duck

Masked Lapwing/plover

White-faced Heron

Swamphen



References:

Chris Hall

Phil Barron - Barron Environmental

Birds SA

<https://birdssa.asn.au/>

Birdlife

https://www.birdlife.org.au/images/uploads/education_sheets/INFO-Nestbox-technical.pdf

https://www.birdlife.org.au/images/uploads/education_sheets/INFO-Nestboxes-nativebirds.pdf

The Spruce

<https://www.thespruce.com/invasive-birds-facts-386723>

Birds In Backyards

<https://www.birdsinbackyards.net/birds/featured/Introduced-birds>

Trevor Waldhuter for pictures

Barossa Bushgardens

653 Research Road

Nuriootpa SA 5355

(08) 8563 8330

bushgardens@barossa.sa.gov.au

www.barossabushgardens.com.au

Opening hours:

Monday and Friday by appointment

Tuesday & Thursday

9 am - 4 pm

Wednesday

9 am - 12.30 pm

Saturday and Sunday closed



**Government
of South Australia**

Northern and Yorke
Landscape Board



The Barossa Council