

# DeLorean Glove Box Service Manual V3.0

Copyright Zilla DeLorean & PJ Grady Inc.  
1987- 2001 V3.0  
For further information:  
deloreanparts.com & pjgrady.com

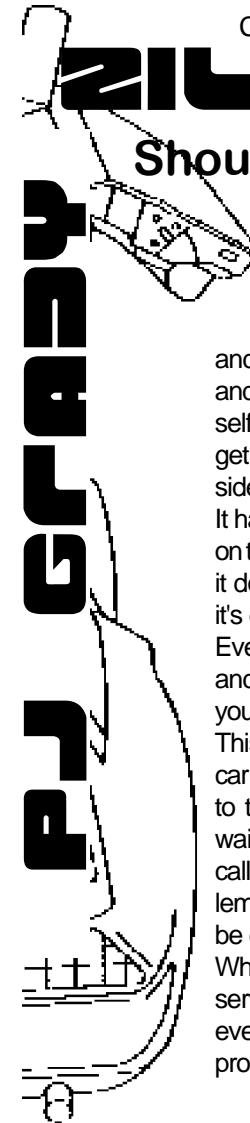

## ZILLA Breakdown Should the time ever come Don't panic

Speaking strictly from experience, a breakdown will occur at the wrong time and in the wrong place. After the feeling of Horror and Aloneness passes and you get a grip on your self-confidence, you'll either grab the phone and get a FLATBED (ONLY) tow truck or you may consider a calm and logical review of this manual.

It has been designed by PJ Grady & Zilla to touch on the most common causes of breakdown. Though it does not go into long winded detail, sometimes it's enough to be pointed in the right direction.

Even if you're not a mechanic, if you can be calm and analytical, you stand a good chance of getting your car back on the road.

This is probably a good time to point out that this car has been known to possess the unusual ability to temporarily "heal itself", merely by sitting and waiting 20 or so minutes while it cools down. Ironically, this seems to apply to some electrical problems as well. This DOES NOT mean you shouldn't be checking into the problem while you wait !

When the trouble spots detailed here are expertly serviced they will rarely reoccur. Many cars however, have been neglected in these areas or improperly repaired so they may return to haunt you.

### SHUTDOWN ALL UNNECESSARY DRAINS ON THE BATTERY

( radio, courtesy lights etc. )

Don't continue to crank the engine, that won't fix the problem, it will just weaken the battery.

USE YOUR ROAD FLARES, that's why you bought them. They're easy to light but keep them away from you at arms length. They tend to spit back sparks as they burn.

YOU SHOULD ALWAYS CARRY A NUMBER OF HAND TOOLS AND A GOOD WORKING FLASHLIGHT !

## Something Dead ? Check for a melted Fuse Socket

Circled Fuses are Prone to Meltdown

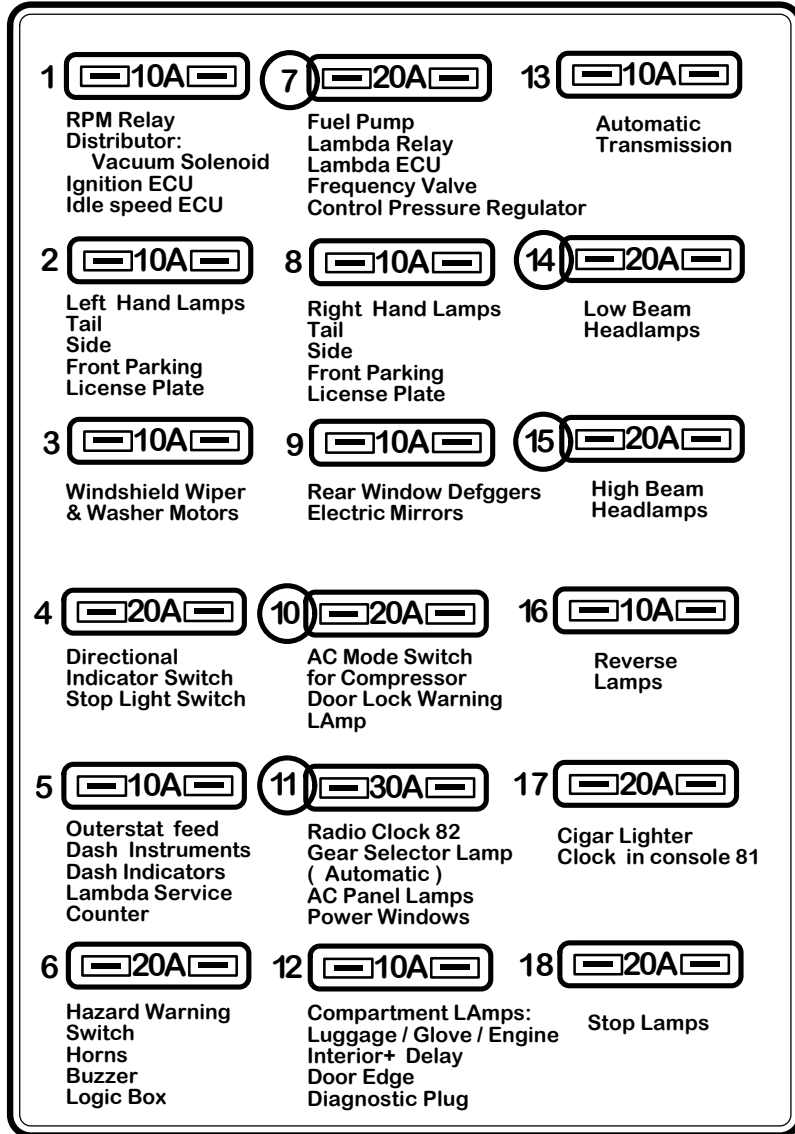

### Fuse Meltdown:

It is generally recommended that all fuses in the fuse box be changed once every 5 years. Any oxidation or discoloration on the fuse terminals is a premature sign of a possible meltdown & failure. All the fuses are NOT prone to failure, just the ones circled. Fuses 7 & 1 will cause engine failure.

### Runs Fine then Stalls

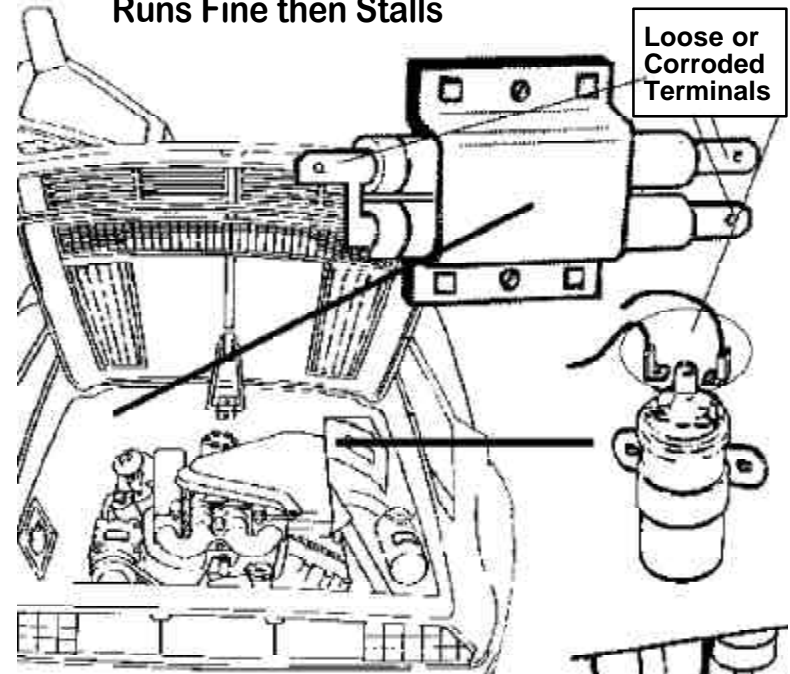

### Engine Died & won't restart Fuel Pump Dead ?

Corroded Terminals  
under weather boot

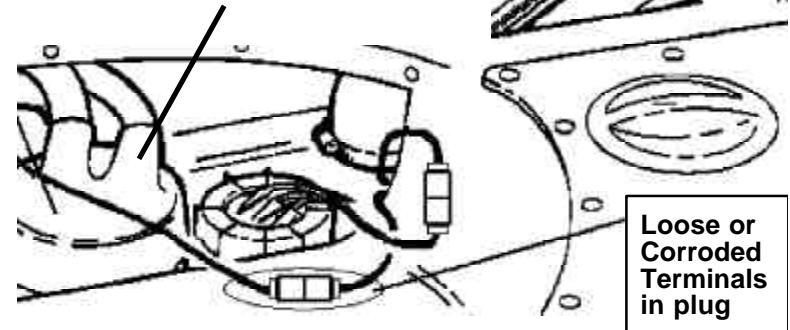

### Important Fuel Pump Note:

The pump doesn't run continuously during start-up. When the ign key is cycled to the "on" ( not the "cranking" ) position, the pump will run for 4 seconds to pressurize the system then shut off. It will cycle again if the ign key is cycled. Remove the spare tire. Listen carefully. It's helpful if you have someone to turn the key for you.

## Engine Died & won't restart

### RPM Relay

Located just below the Door Lock Controller in the relay bay behind the passenger seat.

( see Relay Bay Drawing )

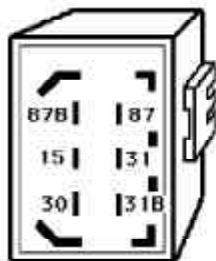

### Relay Plug

- # 30 12 Volts ( Power )
- # 87 Fuel Pump
- # 87B Frequency Valve

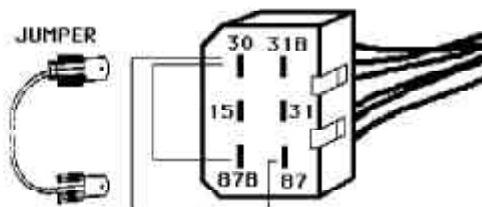

Jumping terminals 30 & 87 will allow you to hear the fuel pump run continuously ( ignition on ). You will hear a low buzzing sound up front in spare wheel well.

If this checks OK & the pump runs with this jumper but will NOT run at all without the jumper, pop off the relay cover of the RPM relay and check the condition of the relay contacts. If they are pitted, the striking material on a pack of matches makes a nice "emery type" sand paper to restore the terminal contact surfaces. Also check to see if the relay has desoldered itself from the circuit board.

Note: This jumper test is for diagnostic purpose ONLY. The engine may not run with the jumper installed ( though it may be worth a try ).

## Engine Dies Suddenly

**INERTIA SENSOR**  
Located in the driver's footwell area  
Electrical connector in bottom

Inertia sensor is designed to cut off fuel from the impact of an accident. Is the connector plug melted? If so, it can be jumpered out to get you running again.

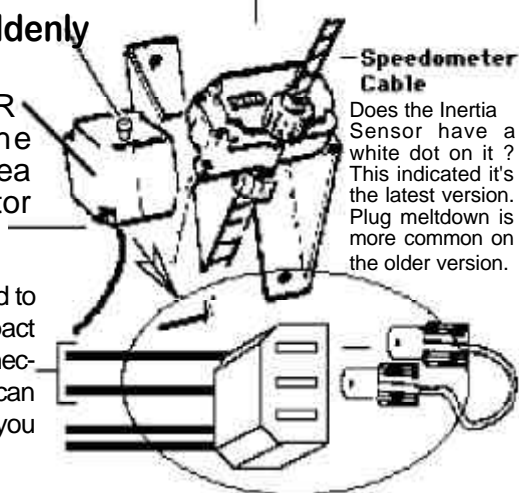

Remove the plug and jump the center to the end with a single wire. Center wire is black and the end wire is black with a purple stripe.

## Engine Will NOT Start / Stalls

also:

- Idle too low /High
- Poor Drivability ( computer control wires )
- Gauges out / Intermittant
- Rear lights out / Intermittant

Terminal(s) will corrode or expand and need to be cleaned and or tightened

Circled #'s are Failure Prone

- ① Ignition / Lights
- 2 Automatic Transmission Automatic Control Start Inhibit ( when in gear )
- ③ Alternator / Lambda / Thermo time switch
- 4 Oil Pressure / Alternator light
- 5 Tail Lamps: Brake & Running side rear marker / Engine light
- ⑥ Idle Circuit
- ⑦ Oxygen Sensor

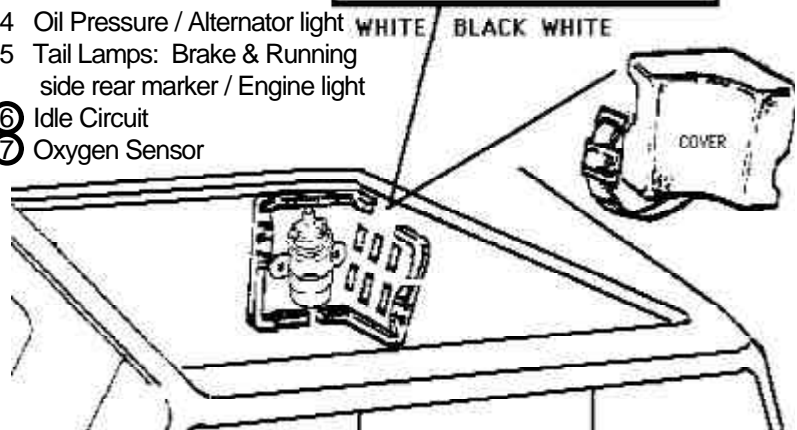
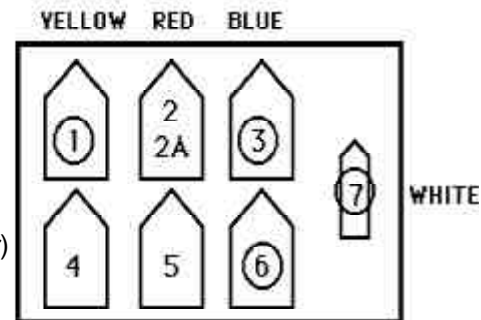

## Poor Acceleration ?

Located on the right hand side of the engine, under the air cleaner, toward the front of the car, bolted to the valve cover

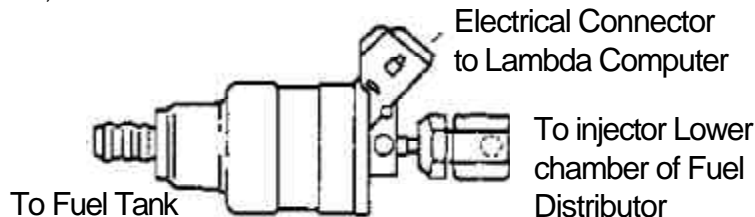

Terminals become corroded in connector -or- the short Ground Wire from the connector to the engine block becomes corroded

# RELAY BAY

Located behind Passenger Seat  
Under Carpet & Wooden Cover  
Below Net

**IMPORTANT SAFETY ISSUE:**  
If you have an Original Door Lock Controller unplug it!  
It's the 12Ga Red wire from the Breaker. Original Controllers  
are well known to malfunction and lock you in  
LockZilla is designed to prevent any such malfunction.

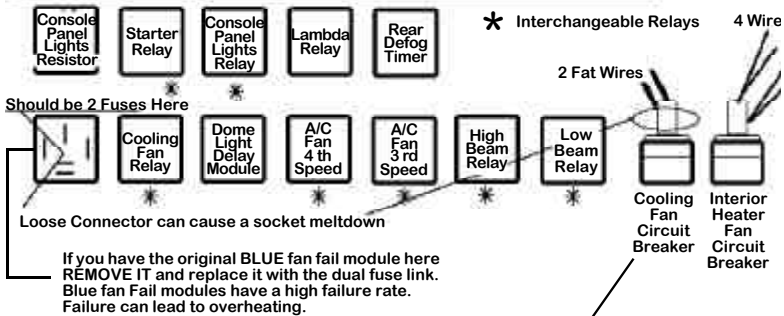

## Overheating Cooling Fans Dead Circuit Breaker Failure

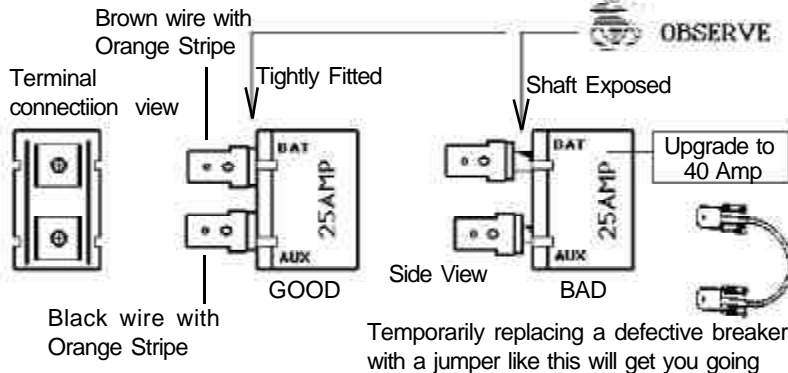

## Hotter than usual in traffic ?

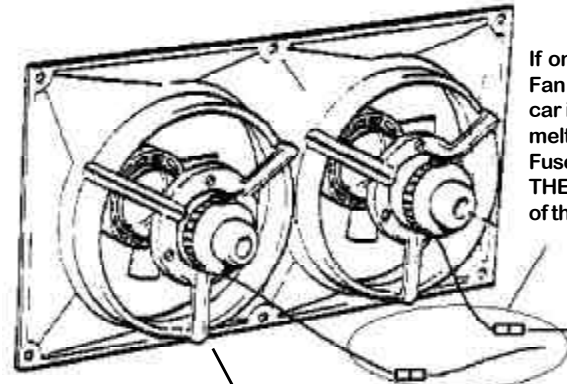

If one fan is out and the Blue Fan Fail relay socket in the car is OK ( Fuse jumpers not melted down ), Fuses in jumpers are OK THEN: Check the connector of the dead fan for corrosion

## Are both Radiator cooling Fans Running ?

NEVER try to touch fans in motion. They are VERY powerful and could do some real damage to your hand. Determine that each is working by inspection if possible. Remember safety first. You can also place your hand below each fan ( near the ground ) one at a time & check for a HUGE breeze. Lastly, you can listen at the front mesh / screen grill below the DMC logo. If you listen carefully, you can hear each fan running.

## Do the Fans spin relatively freely when off ? Is one seized ? ( rare )

It is possible that the bottom plastic arm that supports the fan has broken and caused the fan to jam. This usually happens on lowered cars that hit a driveway apron or other obstruction. It is possible that a split pin will shear. The motor will run but the blade will not turn. Blade will probably not damage the radiator, but this can't be repaired on the road.

## 12 Volt Test Lamp Perhaps the best tool in your arsenal

They come in various styles. A test lamp can often be a more valuable test device than a Digital Volt Ohm Meter. It's simple to use & you get reliable YES / NO answers immediately. Ground the alligator clip to the connection point on the rear window defroster as it's a good test ground. When testing fuses, touch the tip of the test lamp to both silver tabs of the fuse. If it lights up on 1 side and not the other, the fuse is either bad or the fuse socket has overheated and melted. Some fuses will seem dead if the ignition is off or the headlights are off. It depends upon the fuse in Question.

A melted down fuse for the Fuel Pump or Head Lights can be cleaned just enough with a pocket knife, to get you home. Scrape down the terminals on the fuse and socket. Make the socket terminals compress the fuse blades tightly.



## Fan(s) Dead / Overheating ?

### Radiator Cooling Fan Relay Sockets Lower Left Relay Rack passenger side

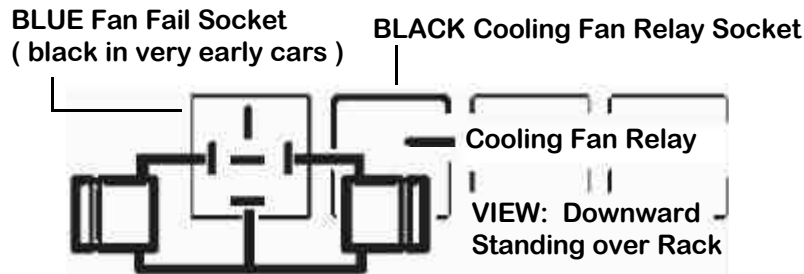

The ORIGINAL BLUE Fan Fail Relay MUST Be removed in ALL Cars & replaced with fuse link shown. When the original Blue Fan Fail Relay Dies, the cooling system QUITs.

This is the spot where FanZilla plugs in, should you decide to upgrade the system to an Intelligent Controller based cooling system. FanZilla connectors are rated for Higher Temperature and are not prone to meltdown.

### Original DeLorean Fan Relay Socket Wiring

**DO NOT MODIFY THIS WIRING FOR ANY REASON !!**

VIEW: Downward Standing over Rack  
Wiring for relay sockets above

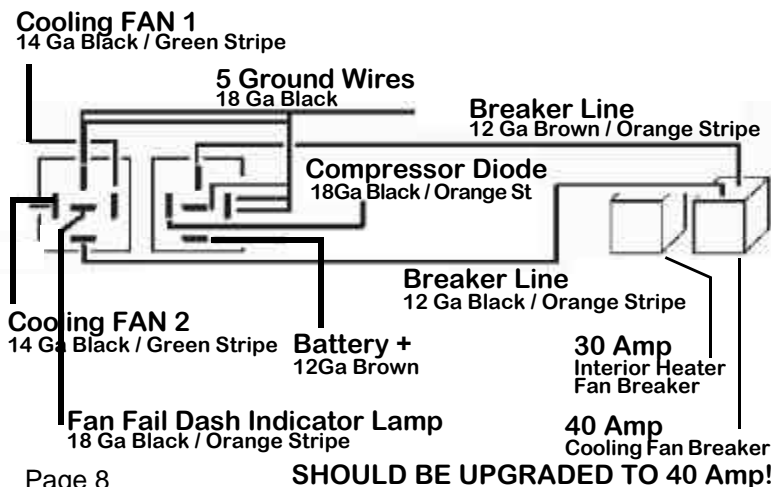

## Overheating ?

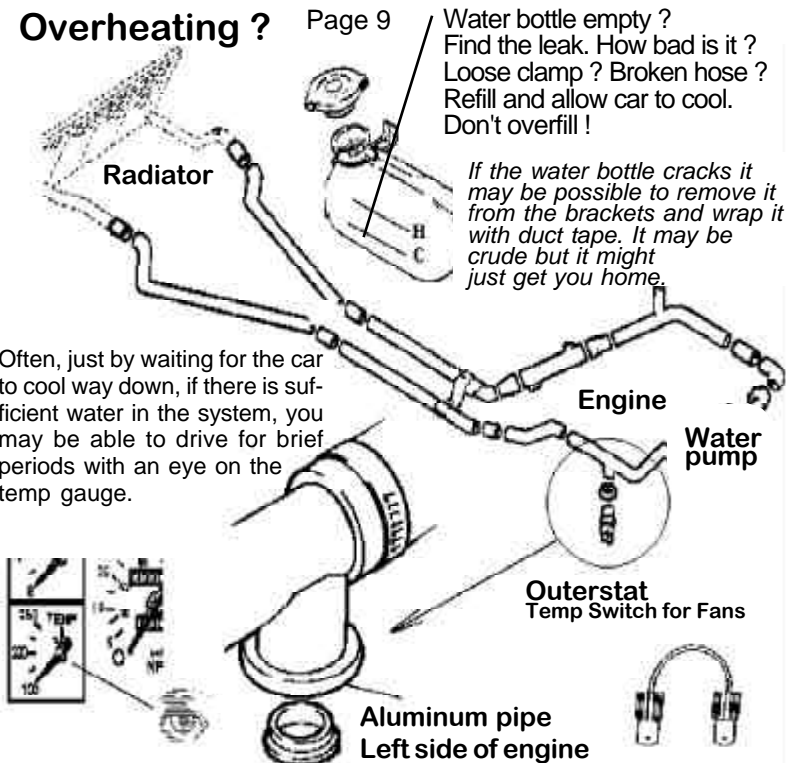

### Fan(s) Dead Overheating ?

Outerstat Switch turns on cooling fans when engine reaches about 200 Degrees F

### Bypassing a bad Outerstat Switch

A double male .25" jumper like the one above can be used to jump out and run the fans continuously till you get home.

### Removing Connectors

To remove this type connector, apply pressure outward and down. Pulling straight down will not work !

However, there's another way: When the Air Conditioning is turned on, the fans will run even if this switch goes bad. The fans will then cycle based on the needs of the AC system.

### Outerstat replacement Zilla now has the Original DeLorean Tooling to make LONG LIFE DEPENDABLE ORIGINAL EQUIPMENT Outerstats

### Why do Outerstats go bad ?

Original Outerstats can die due to age, or as a result of engine overheating Non-original outerstats raise serious questions about : Dependability / Cycle Life Before Failure & Proper Cycling Temps.

### Cooling Fan Schematic

NOTE: The original service manual is incorrect  
**THE MAIN RELAY DOES NOT FEED THE FANS**  
This is the schematic implemented in production

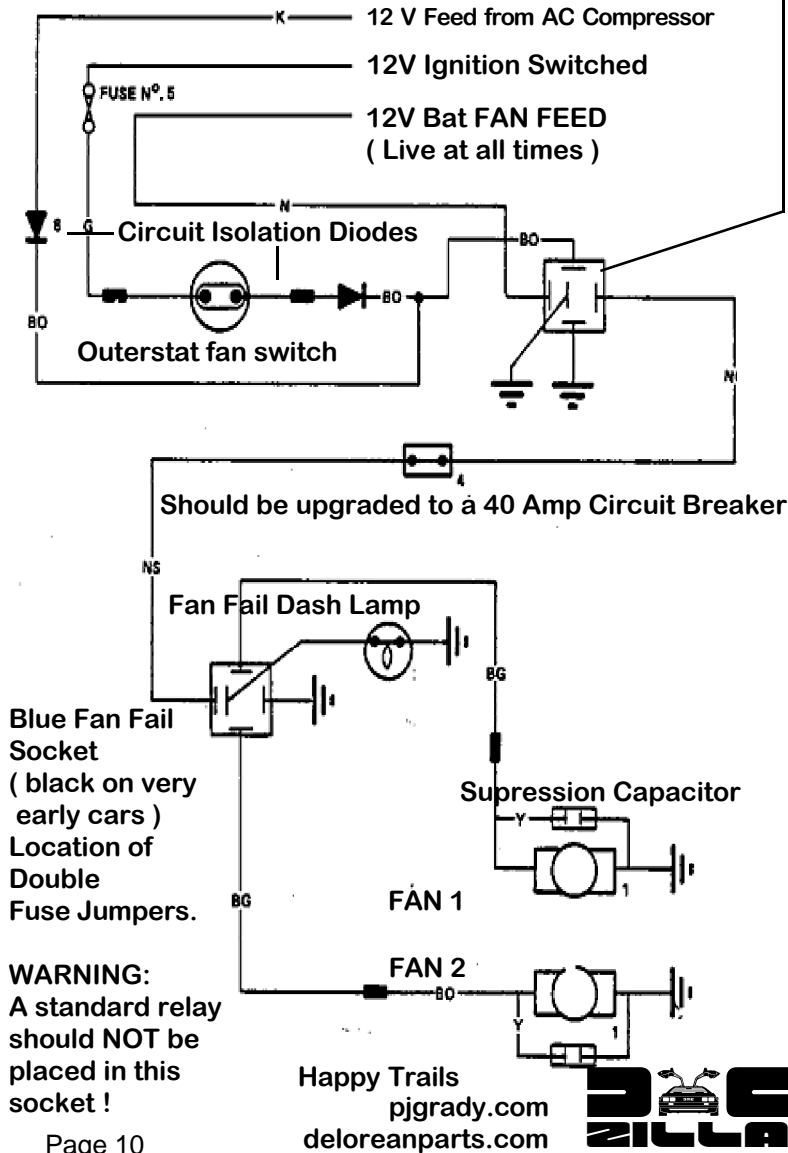
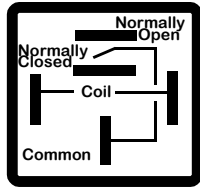

To create a booklet:

Cut all pages the exact size of the cover page allowing for a small margin.

Place 2 staples at the top.

The completed booklet will now be the size of a standard auto map.

If you're really inspired, you may want to cut a piece of cardboard as a backing for the manual to provide some rigidity.

Simply cut it the same size as the page and staple it as the last page.

Happy Motoring,  
 from your friends at  
 PJ Grady Inc [pjgrady.com](http://pjgrady.com) &  
 Zilla [deloreanparts.com](http://deloreanparts.com)