

for R134a

SD Compressor Service Manual

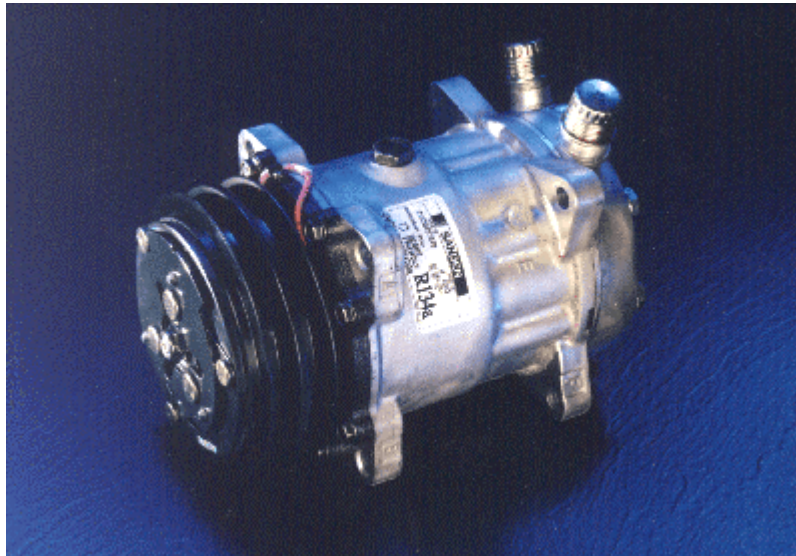

 **SANDEN**

SD COMPRESSOR SERVICE MANUAL

TABLE OF CONTENTS

1. Compressor Models Covered
 2. Compressor Nomenclature
 3. Cautionary Information
 4. R134a Information
 - 4.1 R134a / Pag Oil Handling
 - 4.2 Table of Saturation Temperatures and Pressures
 5. Compressor Identification
 - 5.1 Label
 - 5.2 Date Codes
 6. Compressor Specifications
 - 6.1 Belt Tension
 - 6.2 Speed Rating
 - 6.3 Basic Specifications
 - 6.4 Assembly Torques
 - 6.5 Mounting Angles
 7. Cylinder Head / Porting Guide
 8. Tools
 - 8.1 Special Service Tools
 - 8.2 Standard Tools
 9. Service Procedures
 10. Inspection Procedures
 - 10.1 Leak Checking
 - 10.2 Oil Level Measurement
 - 10.3 Shaft Turning Smoothness Inspection
 - 10.4 Clutch Inspection
 - 10.5 Unusual Noise Not Due to Compressor
 - 10.6 Unusual Noise Due to Compressor
 - 10.7 Valve Plate Test
 11. Field Replaceable Parts
 - 11.1 Compressor Parts
 - 11.2 Clutch Parts
 12. Service Operations - General Information
 13. Oil Charging
 - 13.1 Repairing Compressors
 - 13.2 Replacing Same Type of Compressors
 - 13.3 Replacing Different Types of Compressors
 - 13.4 Oil Charge Determination for Long Hose Application
 - 13.5 Oil Retained in System Components
 14. Clutch Service
 - 14.1 Armature Assembly Removal
 - 14.2 Rotor Assembly Removal
 - 14.3 Field Coil Assembly Removal
 - 14.4 Field Coil Assembly Installation
 - 14.5 Rotor Assembly Installation
 - 14.6 Armature Assembly Installation
 15. Shaft Seal Service
 16. Cylinder Head / Valve Plate Service
 - 16.1 Cylinder Head Removal
 - 16.2 Valve Plate Removal
 - 16.3 Valve Plate and Cylinder Head Installation
 17. Thermal Protector Switch Service
 - 17.1 TPS Testing
 - 17.2 TPS Replacement
 18. High Pressure Relief Valve Service
 19. Converting R-12 Systems to R134a
- ** Service Oil Information

This service manual has been prepared by Sanden International (USA), Inc. It includes information on application, troubleshooting, and repair of automotive air conditioning compressors manufactured by Sanden Corporation and its subsidiaries, in accordance with the appropriate SAE standards for mobile air conditioning. Service operations not described in this manual are not authorized for Sanden compressors. For further information contact your nearest Sanden representative.

Compressor Models

1. Model Conversions

TYPE	R-12	R134a
5 Cylinder	SD-505	SD7B10 / SD5H09
	SD-507	SD5H11
	SD-508	SD5H14
	SD-510	SD7H15HD and SD5H14HD
7 Cylinder	SDB-706	SD7B10
	SD-708	SD7H13
	SD-709	SD7H15
	SDB-709	SD7B15

COMPRESSOR NOMENCLATURE

2. Identification

R-12 Compressors

SD	--	7	09
-----------	-----------	----------	-----------

 Sanden reciprocating wobble plate compressors	 Number of Cylinders	 Approximate displacement, in cubic inches
---	-------------------------	--

SD	7	H	15	HD
-----------	----------	----------	-----------	-----------

 Sanden reciprocating wobble plate compressors	 Number of cylinders	 Port location (H if on head, B if on body)	 Approximate displacement, in cubic centimeters (divided by 10)	 Heavy Duty (HD) or Sealed Heavy-duty (SHD) clutch
--	----------------------------	--	--	--

CAUTIONARY INFORMATION

3.1 Pressure Release

Before disconnecting any lines, always make sure refrigerant has been removed from the A/C system by recovering it with the appropriate recovery equipment.

When working on compressors, separate from the system, always be sure to relieve internal pressure first. Internal compressor pressure can be relieved by removing the oil plug (if necessary) or by removing shipping caps / pads from both ports.

3.2 Recovery of Refrigerant

Never discharge refrigerant to the atmosphere. Always use approved refrigerant recovery / recycling equipment to capture refrigerant which is removed from the A/C system. Do not mix refrigerants in the same piece of equipment; one should be designated for R-12 and another for R134a.

3.3 Handling of Refrigerant

Always wear eye and hand protection when working on an A/C system or compressor. Liquid refrigerant can cause frostbite and / or blindness.

3.4 Ventilation

Keep refrigerants and oils away from open flames. Refrigerants can produce poisonous gasses in the presence of a flame. Work in a well-ventilated area.

3.5 Avoid Use of Compressed Air

Do not introduce compressed air into an A/C system due to the danger of contamination.

3.6 Warranty for Recycled Refrigerant

The warranty offered by Sanden International (U.S.A.), Inc., on air conditioning compressors when used with recycled refrigerant will be the same as for new refrigerant provided that the following SAE standards are met:

	R-12	R134a
Refrigerant Purity	J1990	J2099
Recycling Machine	J1989	J2210

Recycling machines must be validated to the appropriate SAE standard by Underwriters Laboratories. Recycled refrigerant from other sources must meet the appropriate ARI standards. Failure to comply with these provisions may void any warranty on the compressor.

R134a INFORMATION

4.1 R134a / PAG Oil Handling Precautions

As a conscientious member of the global community, Sanden Corporation with its subsidiaries is committed to the elimination of CFC-based refrigerants. This manual focuses on service information for Sanden compressors intended for use with R134a and PAG oils.

4.1 (Cont.)

1. Always follow safety precautions described in Section 3.
2. Do not discharge R134a into the atmosphere. Even though its ozone depletion potential is zero, it does have global warming potential. Recovery and recycling are mandated by the Clean Air Act. Use recovery equipment designated only for R134a. Never introduce another refrigerant into the R134a equipment.
3. Never mix R134a with other refrigerants or A/C systems failure is likely to occur.
4. Use only Sanden specified PAG lubricants for R134a systems using Sanden compressors. If other lubricants are used, A/C system failure is likely to occur.
5. Never introduce R134a or PAG oil into a system not designed for them except when following the appropriate retrofit procedure described in Section 19.
6. The Sanden specified PAG oils used in R134a systems absorb atmospheric moisture very quickly. Moisture in the A/C system can cause major damage or failure.
 - Never leave PAG oil exposed to air for a prolonged time. Tightly reseal the oil container immediately after each use.
 - During A/C system repair, cap all fittings as soon as opened and leave capped until just before they are reconnected.
 - If a repair is performed on an R134a compressor or system, evacuate the system for at least 45 minutes before recharging to ensure the removal of moisture which may have been absorbed by the PAG oil in the compressor and system.

4.2 Table of Saturation Temperatures and Pressures

Temp.(°F)	Pressure (psig)	Temp.(°F)	Pressure (psig)	Temp.(°F)	Pressure (psig)
-40	-7.2 in. Hg	25	22	105	135
-30	-4.8 in. Hg	30	26	110	147
-20	-1.7 in. Hg	40	35	115	159
-15	0	50	45	120	172
-10	2	60	57	130	200
-5	4	70	71	140	231
0	6	80	85	150	264
5	9	85	95	160	301
10	12	90	104	180	3
15	15	95	114	200	485
20	18	100	124	210	549

COMPRESSOR IDENTIFICATION

5.1 Label

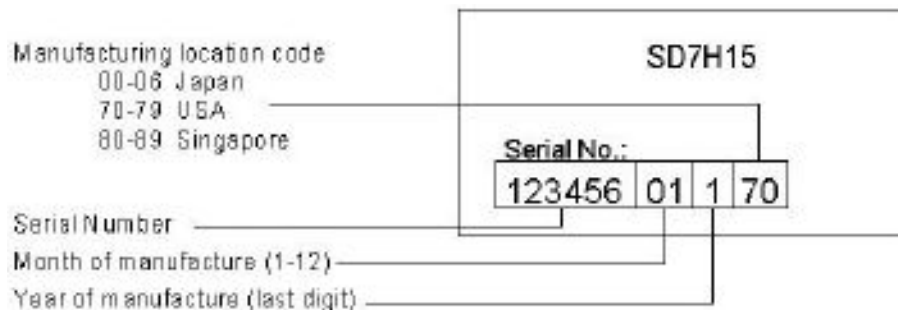

5.2 Manufacturing Date Codes Stamped on Compressor - Manufactured in USA Only

Manufacturing date codes are stamped on the mounting e or boss at the front left of the compressor as seen when facing the clutch, with oil plug or adaptor up.

Year of manufacture (first digit):
(i.e. 3 indicates manufacture in 1993)
Month of manufacture (last digit):
Jan. - Sept.: 1 - 9
Oct.: X
Nov.: Y
Dec.: Z

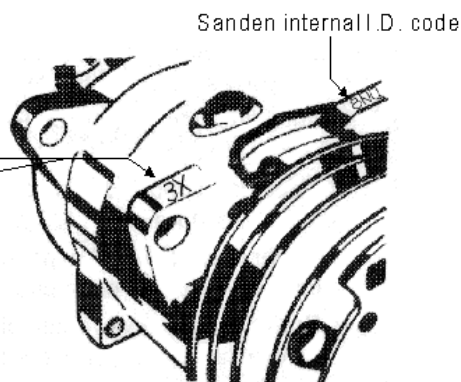

COMPRESSOR SPECIFICATIONS

6.1 Belt Tension

Grooves	Tension, lb (kgf)
A	121 ± 5 (55 ± 2)
B	132 ± 5 (60 ± 2)
C	132 ± 5 (60 ± 2)
M	132 ± 5 (60 ± 2)
PV4	132 ± 5 (60 ± 2)
PV6	198 ± 5 (90 ± 2)

(PolyVee tension based on 33 lb (15kgf) per groove).

6.2 Speed Rating

Model	Clutch Type	Maximum RPM	
		Constant	Downshift
SD5H14	Std.	6,000	7,000
SD5H14	HD	4,000	6,000
SD7B10	All	6,000	7,000
SD7H13	All	6,000	8,000
SD7H15	Std.	6,000	8,000
SD7H15	HD	4,000	6,000
SD7H15	SHD	4,000	4,000

6.3 Basic Compressor Specifications

Model	Refrigerant	Displacement cu.in. (cc)	Typical Weight, lb. (kg.)			Standard Oil Charge			Rotation
			Compressor	Clutch	Assembly	Oil Type	System Type	Amount fl. oz. (cc)	
SD5H14	R134a	8.4 (138)	11.2 (5.1)	6.0 (2.7)	17.2 (7.8)	SP-20	TXV	7.2±0.5 (210±15)	Either Way
							CCOT	No standard	
SD7B10	R134a	6.1 (100)	5.9 (2.7)	3.3 (1.5)	9.2 (4.2)	SP-10	TXV	No standard	CW (Clock wise only)
SD7H13	R134a	7.9 (129)	9.3 (4.2)	4.6 (2.1)	13.9 (6.3)	SP-20	TXV	4.6±0.5 (135±15)	CW (Clock wise only)
SD7H15 /HD	R134a	9.5 (155)	9.9 (4.5)	5.3 (2.4)	15.2 (2.4)	SP-20	TXV	4.6±0.5 (135±15)	CW (Clock wise only)
							CCOT	8.1±0.5 (240±15)	
SD7H15 /SHD	R134a	9.5 (155)	9.9 (4.5)	7.7 (3.5)	17.6 (8.0)	SP-20	TXV	4.6±0.5 (135±15)	CW (Clock wise only)
							CCOT	8.1±0.5 (240±15)	

6.4 Assembly Torques

Item	ft -lb	N-m	kgf-cm
Armature retaining nut, 1/2" - 20	22.4 ± 2.9	30.4 ± 3.9	310 ± 40
Armature retaining nut, M8	13.0 ± 2.2	17.7 ± 2.9	180 ± 30
Cylinder head bolts, M6	10 ± 2.2	13.7 ± 2.9	140 ± 30
Cylinder head bolts, M8	25.3 ± 3.6	34.3 ± 4.9	350 ± 50
Oil filler plug	14.5 ± 13.6	19.6 ± 4.9	200 ± 50
Hose fitting 1" - 14 rotolock	26.7 ± 2.9	36.3 ± 3.9	370 ± 40
7/8" Tube-O	23.9 ± 2.9	32.4 ± 3.9	330 ± 40
3/4" Tube - O	17.3 ± 2.5	23.5 ± 3.4	240 ± 35
Pad fitting bolt, M10	28.9 ± 2.9	39.2 ± 3.9	440 ± 40
Pad fitting bolt 3/8" -24	28.9 ± 2.9	39.2 ± 3.9	440 ± 40
Pad fitting bolt, M8	26.3 ± 2.9	34.3 ± 3.9	350 ± 40
Clutch lead wire clamp screw	11 ± 3 in•lb	1.3 ± 0.3	13 ± 3
High pressure relief valve	7.2 ± 1.4	9.8 ± 2.0	100 ± 20
Thermal protector switch clamp bolt	7.2 ± 2.2 - 1.4	9.8 ± 2.9 - 2.0	100 ± 30 - 20
Clutch dust cover screws (6 - M5)	6.5 ± 1.4	9 ± 2	90 ± 20
Clutch dust cover screws (3 - 1/4" - 20)	2.7 ± 0.9	3.6 ± 1.2	37 ± 12

6.5 Acceptable Mounting Angles

All SD - R134a Compressors

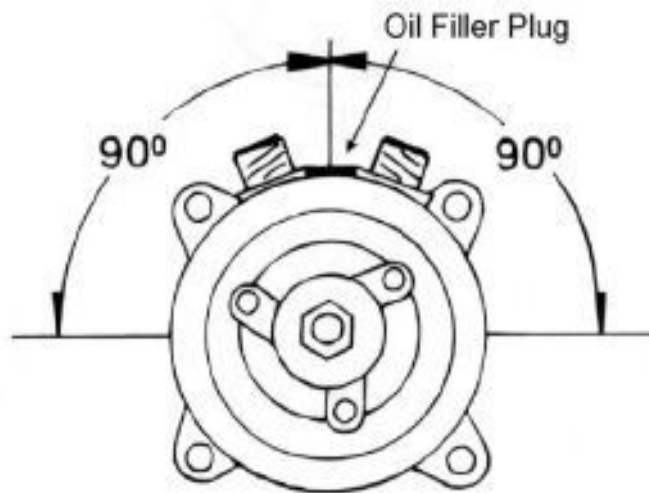

CYLINDER HEAD / PORTING GUIDE

7. SD R143a COMPRESSOR SERIES

For SD5H14, SD7H13, SD7H15 and SD7H15HD / SHD Units

Sanden Service Kit Part No.	Name	Position on Cylinder head	Hose Port Information			SD Compressor Series			
			Suction Port Dimension/Type	Discharge Port Dimension/Type	TPS or Switch?	5H14	7H13	7H15	7H15 HD/SHD
9580-9630	C	Vertical	Tube-O 1" - 14 rotolock	Tube-O 1" - 14 rotolock	No	X			
TDB	FL	Vertical	Tube-O #10 (7/8")	Tube-O #8 (3/4")	No	X			
9034-9630	K	Horizontal	Tube-O #10 (7/8")	Tube-O #8 (3/4")	No	X			
9699-9630*	M	Horizontal	Tube-O 1" - 14 rotolock	Tube-O 1" - 14 rotolock	No	X			
9150-9630*	Q	Horizontal	GM Pad, 3/8" - 24 Bolt	GM Pad, 3/8" - 24 Bolt	No	X			
9695-9630*	QH	Horizontal	GM Pad, 3/8" - 24 Bolt	GM Pad, 3/8" - 24 Bolt	Yes	X			
9298-9630*	U	Vertical	Pad-M10 x 1 Bolt	Pad-M10 x 1 Bolt	No	X			
9517-9630*	UB	Vertical	Pad-M10 x 1.25 Bolt	Pad-M10 x 1.25 Bolt	No	X			
9516-9630*	UB	Horizontal	Pad-M10 x 1.25 Bolt	Pad-M10 x 1.25 Bolt	No	X			
7412-9630	CB	Vertical	Tube-O 1" - 14 rotolock	Tube-O 1" - 14 rotolock	No		X	X	X
7832-9630	JD	Vertical	Tube-O #10 (7/8")	Tube-O #8 (3/4")	No		X	X	X
7863-9630	JE	Vertical	Tube-O #10 (7/8")	Tube-O #8 (3/4")	No		X	X	X
7862-9630	KG	Horizontal	Tube-O #10 (7/8")	Tube-O #8 (3/4")	No		X	X	X
7406-9630*	MD	Horizontal	Tube-O 1" - 14 rotolock	Tube-O 1" - 14 rotolock	No		X	X	X
7433-9630	QC	Horizontal	GM Pad, 3/8" - 24 Bolt	GM Pad, 3/8" - 24 Bolt	No		X	X	X
7484-9630	QD	Horizontal	Pad-M10 x 1.25 Bolt	Pad-M10 x 1.25 Bolt	No		X	X	X
7200-9631	UK	Vertical	Pad-M10 x 1.25 Bolt	Pad-M10 x 1.25 Bolt	No		X	X	X

A) Sanden R134a compressors do not offer the option of charging valves on the compressor.

B) * Indicates that a compressor featuring this cylinder head should not be mounted with the suction port at the bottom.



SERVICE TOOLS

8.1 Special Service Tools

These tools can be obtained from your local tool supplier.

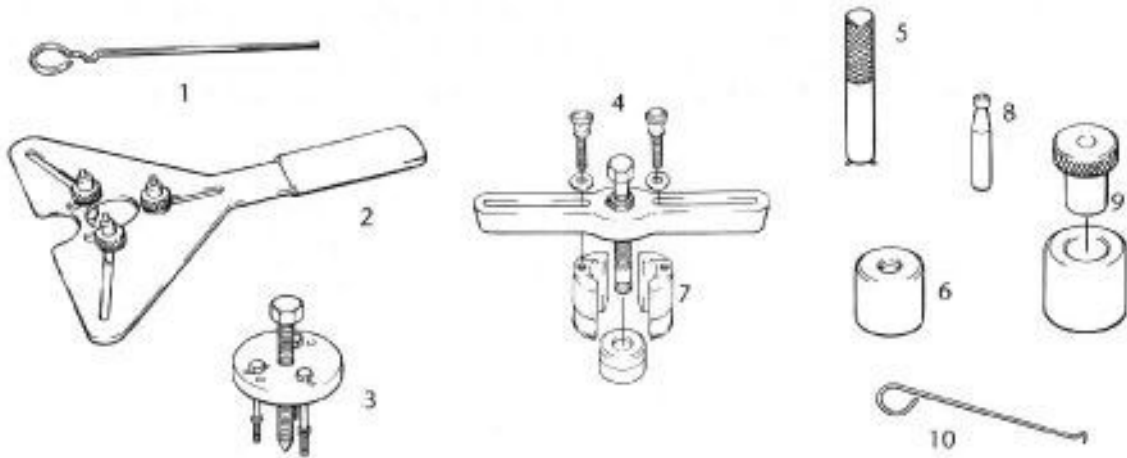

1. Oil Dipstick	5. Lip Seal / SD7 Seal Plate Tool	9. Rotor Installation Driver
2. Armature Plate Spanner	6. Armature Driver	10. O-Ring Hook
3. Armature Plate Puller	7. Rotor Puller Jaws	
4. Rotor Puller Set	8. Shaft Seal Protective Sleeve	

8.2 Standard Tools

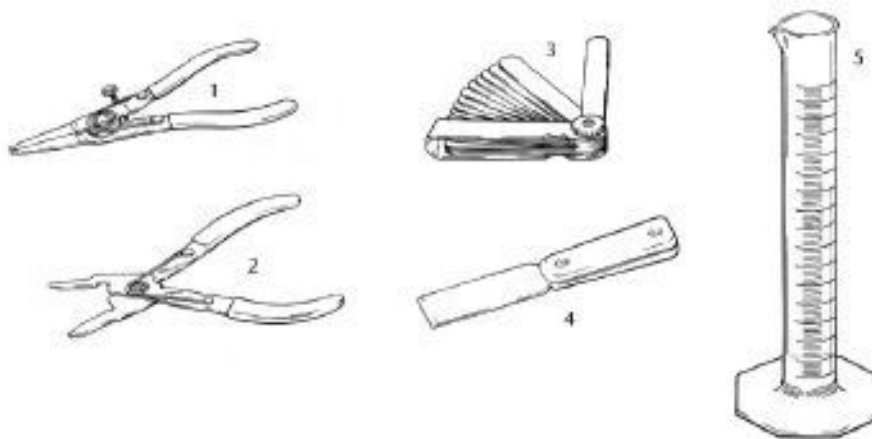

1. External Snap Ring Pliers	4. Gasket Scraper
2. Internal Snap Ring Pliers	5. Graduated Cylinder
3. Feeler Gauges	

SERVICE PROCEDURES

9. TROUBLESHOOTING CHART

This chart refers specially to the Sanden compressor. During diagnosis follow the inspection procedures in the sequence shown until a defect is found. Then perform the repair in the Cause and Remedy Section. If this repair does not fully solve the problem, proceed to the next inspection step.

Symptom	Problem Diagnosis and Inspection	Cause and Remedy		
LACK OF COOLING	Smooth Running Compressor Unusually high suction pressure with unusually low discharge pressure	1 Valve Plate Test 12	Replace or Repair: Broken Head or Block Gasket 22 Broken or Deformed Reed Valve Foreign Substance Under Reed Valve or Gasket 25	
		1 Check for low Refrigerant Charge		
	Unusually low suction and discharge pressure	2 Leak Check Compressor 9	Replace or Repair: Shaft Seal Leak 20 Cylinder Head Leak Gasket Leak Oil Filler Plug Leak Cracked Cylinder Block Front Housing O-Ring Leak 25	
		3 Leak Check and Diagnose System (See System Service Manual)		
	Intermittent or Inoperative	1 Check Belt Tension 4		
		2 Check Clutch Air Gap 11	Adjust Air Gap 20	
	Rough Running or Intermittent or Inoperative	3 Check Clutch Volts, Amps, Coil Lead Wire 10	Replace or Repair: Broken Lead Wire 17 Clutch Coil Defect - Internal System Ground (See System Manual) 20	
		4 Shaft Turning Smoothness Test 10	Compressor Failure - Internal	
	Rough Running			
Unusual Noise	Clutch engaged	1 Check Compressor Mounting Components 11		
		2 Check Engine Components 11		
	Unusual Noise	3 Check for Intermittent or Slipping Clutch 10	Adjust Air Gap - Defective Coil 20	
		4 Check for Proper Refrigerant Charge	Recharge and Recheck	
		5 Check Clutch Bearing 10	Replace Rotor/Armature Assembly 17-19	
		6 Oil Level Procedure 9	Restore to Proper Level 19	
		7 Shaft Turning Smoothness Test 10	Compressor Failure (Internal)	
		8 Remove Valve Plate and Inspect 23	Replace or Repair: Broken Discharge Valve Reed or Retainer 22 Broken Suction Valve Reed Broken Gasket 25	
		Clutch disengaged "chattering"	1 Check Air Gap 11	Replace or Repair: Adjust Air Gap 17 Defective Clutch Pulley or Front Plate 20

INSPECTION PROCEDURES

10.1 Leak Checking

1. **Visual Inspection** - Although oil seepage does not necessarily indicate leakage of refrigerant, it should be considered a sign that a leak may exist. Look for the following items:
 - Oil seepage in shaft seal area (between clutch and compressor) - repairable.
 - Pinching or extrusion of front housing O-ring - nonrepairable.
 - Oil around cylinder head (gaskets, service valves, fittings) - repairable.
 - Oil around oil plug - repairable.
 - Stripped threads - nonrepairable.
 - Oil around crack in compressor body - nonrepairable.
2. **Soap Bubble Detection** - Any leak showing up as bubbles on the compressor will require repair.
3. **Shop Type Electronic Detectors**
 - Ensure that the detector being used is sensitive to R134a refrigerant. Many leak detectors intended for R-12 cannot detect R134a leaks.
 - Use the leak detector in accordance with the manufacturer's instructions.
 - The leak rate at any portion of the compressor should not exceed 1.0 oz./yr. Make sure that a suspected leak is an actual flow of refrigerant, not a small pocket of refrigerant trapped in a recess. Cleaning the suspect area with soap and water (never a solvent) or blowing off the area with compressed air can help confirm a suspected leak.
 - Leak check procedures should be in accordance with SAE J1628.
4. **Leak Detection Dyes** - The use of leak detection dyes is not recommended by Sanden as their chemical compositions are proprietary and their effects on Sanden oils and elastomers are unknown at this time.

10.2 Oil Level Measurement (In Vehicle)

Oil level in the compressor should be checked when a system component has been replaced, when an oil leak is suspected, or when it is specified as a diagnostic procedure.

1. Run the compressor for 10 minutes with the engine at idle.
2. Recover all refrigerant from the system, slowly so as not to lose any oil.
3. Determine the mounting angle of the compressor from horizontal (i.e., oil plug or adapter on top). This is most readily done by using a machinist's universal level, if access to the compressor permits.

10.2 (Cont.)

- Remove the oil filler plug. Using a socket wrench on the armature retaining nut, turn the shaft clockwise until the counterweight is positioned as shown.

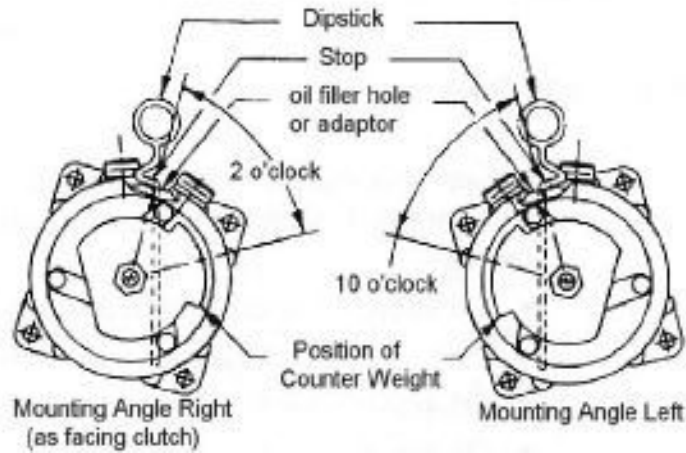

- Insert oil dipstick up to the stop, as shown in the figure above, with the angle pointing in the correct direction.

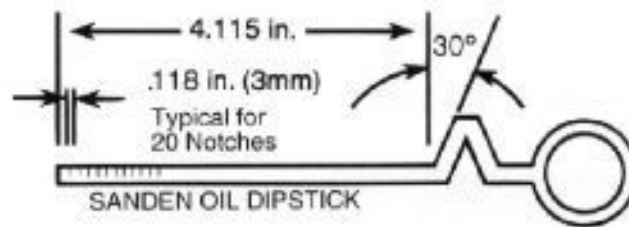

- Remove dipstick and count number of notches covered by oil.
- Add or subtract oil to meet the specifications shown in the table.
- Reinstall oil plug. Seat and O-ring must be clean and not damaged. Torque to 11-15 ft•lb (15-20 N•m, 150-200 kgf•cm).

Mounting Angle (Degrees)	Acceptable oil level in increments	
	SD5H14	SD7H15
0	3-5	5-7
10	4-6	6-8
20	5-7	7-9
30	6-8	8-10
40	7-9	9-11
50	8-10	10-12
60	8-10	11-13
90	8-10	16-18

10.3 Shaft Turning Smoothness Inspection

1. If on vehicle, remove refrigerant from A/C system and disconnect hoses.
2. If on bench, uncap fittings.
3. Using a socket wrench on the armature retaining nut, turn the shaft clockwise only.
4. If severe rough spots or catches are felt while turning shaft, the compressor has been damaged internally and must be replaced.

10.4 Clutch Inspection

1. Measure voltage at clutch. Low voltage at the clutch may be due to poor ground or power connection, or problems with the vehicle electrical system. Check for tight fit of field coil retaining snap ring.
2. Measure current draw when clutch is engaged. Normal current should be 3.6 - 4.2A at 12VDC.
 - Overcurrent- Short circuit within field coil or in compressor circuit.
 - No current - Open circuit.
 - If a short or open is found in the field coil, it must be replaced.
3. Air Gap
 - Clutch air gap should be 0.016 - 0.031 in (0.4 - 0.8 mm). Measure with a feeler gauge.
 - Adjust as per Section 14.6
4. Suspected Clutch Rotor Bearing Noise
 - Remove drive belt.
 - With clutch disengaged, rotate pulley by hand. If excessive roughness or wobble is found, replace the clutch rotor assembly.

10.5 Unusual Noise Not due to Compressor

Unusual noises may be caused by components other than the compressor.

1. Compressor Mounting - Check for:
 - Loose belt - see belt tension specifications.
 - Broken bracket or compressor mounting ear. Replace broken component.
 - Missing, broken, or loose mounting bolts. Replace, reinstall, or tighten.
 - Flush fit of compressor to bracket and vehicle engine. Replace any part not properly fitted.
 - Loose or wobbling crankshaft pulley. Check for damage to pulley, incorrect center bolt torque or center bolt bottoming. Repair to vehicle manufacturer's specifications.
 - Bad idler pulley bearing. Replace if necessary.
2. Other Engine components - Check for noise in:
 - Alternator bearing
 - Air pump (if present)
 - Water pump bearing
 - Valves
 - Timing belt or chain
 - Power steering pump (if present)
 - Loose engine mount bolts.

10.6 Unusual Noises Due to Compressor

1. Suction pressure less than about 5 psig can cause unusual noise. Charge refrigerant to proper amount and test by applying heat to evaporator to increase suction pressure.
2. Clutch bearing--See clutch Inspection in section 10.4
3. Oil level--insufficient oil can cause unusual noise. See Oil Level Check Procedure in Section 10.2.
4. Valve Noise--test for valve plate assembly failure per Valve Plate Test Procedure in Section 10.7.

10.7 Valve Plate Test

1. Suction or discharge valve breakage will cause a clacking sound at idle.
2. If head gasket failure occurs, discharge pressure will be low and suction pressure will be high at idle.
3. Valve and gasket condition can be checked as follows:
 - Connect gauge set to suction and discharge service valves.
 - Run compressor for 5 minutes at idle and stop.
 - Observe time for discharge pressure and suction pressure to equalize. If less than 2 minutes, in a TVX system, a valve or gasket may be damaged. CCOT systems will equalize more quickly.

FIELD REPLACEABLE PARTS

11.1 Compressor

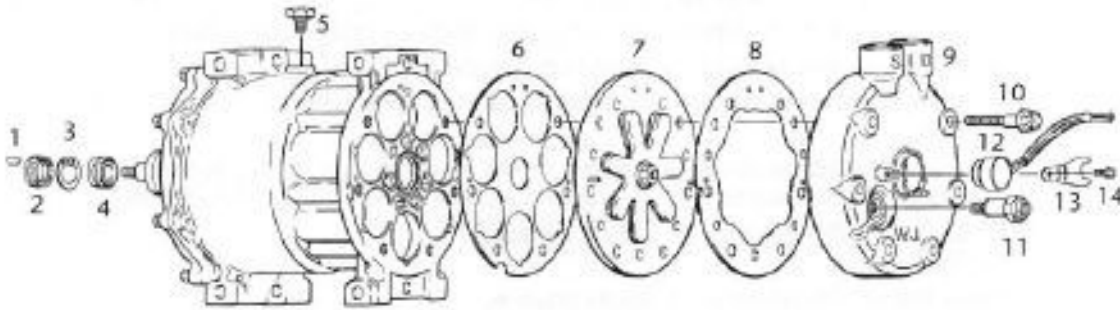

1. Shaft Key*	7. Valve Plate Assembly*	13. TPS Clip (Optional)
2. Felt Ring*	8. Head Gasket*	14. TPS Screw (Optional)
3. Shaft Seal Snap Ring*	9. Cylinder Head*	15. Shaft Seal Kit - 2, 3 & 4
4. Lip Seal with O-ring*	10. Cylinder Head Bolt	16. Valve Plate Kit - 6, 7 & 8
5. Oil Plug	11. Pressure Relief Valve (Optional)	17. Cylinder Head Kit - 8 & 9
6. Block Gasket*	12. Thermal Protector Switch (Optional)	18. Gasket Kit - 6 & 8

11.2 Clutch

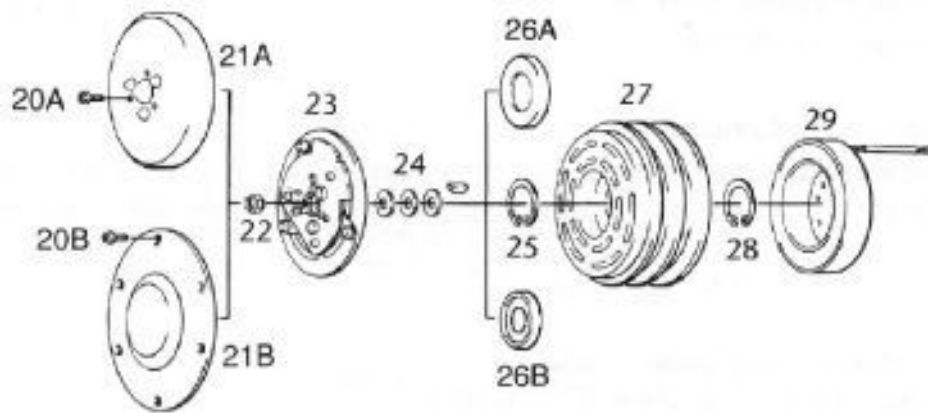

20A. Armature Dust Cover Screw (SD-5)	23. Armature Plate*	27. Rotor Assembly*
20B. Armature Dust Cover Screw (SD-7)	24. Clutch Shims*	28. Field Coil Assembly Snap Ring*
21A. Armature Dust Cover (SD-5)	25. Rotor Snap Ring*	29. Field Coil Assembly
21B. Armature Dust Cover (SD-7)	26A. Rotor Bearing Dust Cover (SD-5)	30. Accessory Kit - 1, 22, 24, 25 & 28
22. Shaft Nut*	26B. Rotor Bearing Dust Cover (SD-7)	31. Armature / Rotor Assembly Kit - 23 & 27

*Sold in kits only.

Service Operations - General Information

12. General Service Information

It is recommended that a new receiver-drier or accumulator-drier be installed if a compressor is replaced or an internal repair is made.

- Keep dirt and foreign material from getting on or into the compressor or the A/C system. The area around the A/C hose fittings should be carefully cleaned with a non-petroleum based solvent before the connections are broken. All parts to be reused or installed should be cleaned with a non-petroleum based solvent and blown dry with clean compressed air or lint-free cloths.
- Trouble-free installation and operation of an SD compressor require:
 - Correct pulley alignment
 - Correct fit of compressor mounting surfaces to the bracket and correct fit of the bracket to the engine. Clearance between compressor and bracket should not exceed 0.2mm (0.008in) per ear for ear-mount compressors or 0.4mm (0.016in) total for 2 ears.
 - Correct torque of all mounting bolts and nuts
 - Correct drive belt tension
- Never operate the compressor at high speed or for a prolonged time without a sufficient refrigerant charge in the system. Probable results are overheating, internal damage and seizure.
- If an internal repair is performed on an R134a compressor, evacuate the A/C system for at least 45 minutes before recharging to remove moisture which may have been absorbed by the PAG oil in the compressor.
- Parts which require lubrication before assembly, such as O-rings, should be lubricated with **clean 5GS** refrigerant oil

Service Operations - Oil Charging

13.1 Compressor Repaired Internally and Reinstalled in the System

1. Before any internal repair is done, drain the oil from the compressor.
 - Remove the oil plug and drain as much oil as possible into a suitable container.
 - Remove the caps (if present) from suction and discharge ports
 - Drain oil from the suction and discharge ports into a suitable container while turning the shaft clockwise only with a socket wrench on the armature retaining nut.

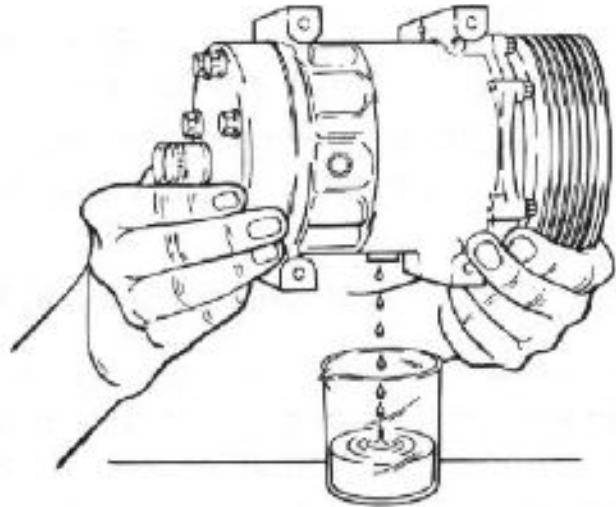

2. Measure and record the amount of oil drained from the compressor.
3. Inspect the oil for signs of contamination such as discoloration or foreign material.
4. Perform repair to the compressor.

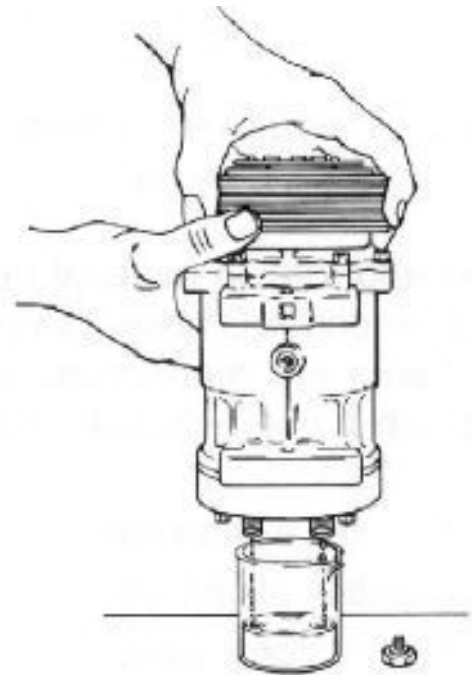

13.1 (Cont.)

5. Add the same amount of new oil to the compressor as was measured in step 2. Be sure to use the correct oil for the compressor as shown in Section 6.3.
6. Reinstall oil plug. Seal and O-ring must be clean and not damaged. Torque to 11-15 ft•lb (15-20 N•m, 150-200 kgf•cm). Be careful not to cross thread the oil plug.
7. It is recommended that the oil quantity be confirmed after reinstallation of the compressor to the vehicle as per Section 10.2.

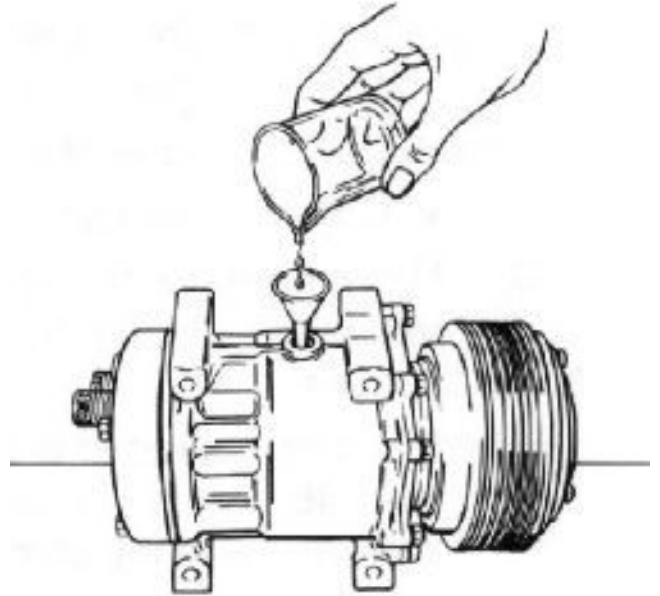

13.2 Sanden Compressor Replaced by a New Sanden Compressor of the Same Type

1. Drain oil from the old compressor; measure and record the amount as per the procedure in section 12.1.
2. Drain oil from the new compressor as per section 13.1
3. Add new oil of the correct type to the new compressor as shown in section 6.3. Use the same quantity as was removed from the old compressor in step 1.
4. Reinstall oil plug. Seal and O-ring must be clean and not damaged. Torque to 11-15 ft•lb (15-20 N•m, 150-200 kgf•cm).
5. It is recommended that the oil quantity be confirmed after installation of the new compressor to the vehicle per section 10.2.

13.3 Sanden Compressor Used to Replace a Compressor of a Different Type

This section applies to replacement of another manufacturer's compressor or to the replacement of a Sanden compressor by a different model Sanden compressor. In this case, the procedure of Section 13.2 should be followed, except that the oil quantity must be confirmed after installation of the new compressor to the vehicle as shown in Section 10.2.

13.4 Oil Charge Determination for Long Hose Applications

13.4.1 TXV Systems, Less than 56 oz. (1600g) Refrigerant Charge

1. The desired oil charge for the systems with unusually long hoses, such as trucks, tractors, etc., can be determined based on the total refrigerant charge when less than 56 oz. (1600g) refrigerant is used.
2. Calculate the desired oil charge as below:

SD5H14: Oil amount (fl.oz.) = (Refrigerant charge in oz. x 0.125) + 1.35. Oil amount (cc) = (Refrigerant charge in grams x 0.125) + 40.

SD7H15: Oil amount (fl.oz.) = [(Refrigerant charge in oz. x 0.06) + 2.2] ÷ 0.9. Oil amount (cc) = [(Refrigerant charge in grams x 0.06) + 60] ÷ 0.9.

3. For a new compressor to be used in this type of system, subtract the standard oil charge shown in Section 6.3 from the desired total oil charge to determine how much oil should be added to the compressor.
4. Remove the oil filler plug and charge the compressor with the amount of additional oil determined in step 3. Use only new oil of the correct type as shown in Section 6.3.
5. Reinstall oil plug. Seat and O-ring must be clean and not damaged. Torque to 11-18 ft•lb (15-25 N•m, 150-200 kgf•cm).

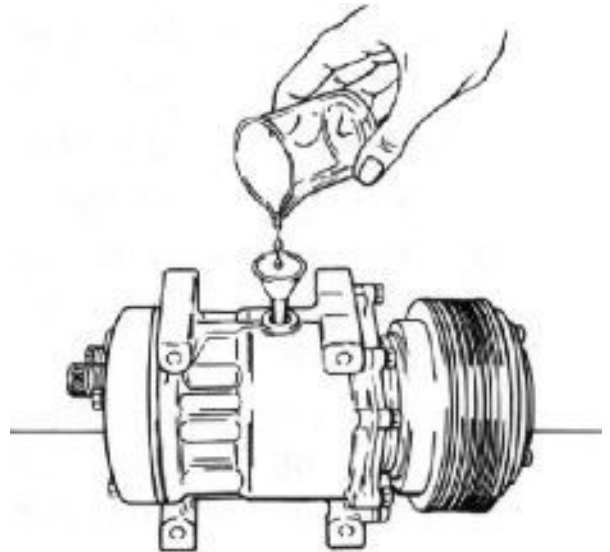

13.4.2 TXV Systems, More Than 56 oz. (1600g) of Refrigerant

For systems with more than 56oz. (1600g) refrigerant, on-vehicle testing is required to determine oil charge.

1. Charge system with refrigerant.
2. Set up the vehicle as follows:
 - Doors open
 - Maximum blower speed
 - Ambient temp. at least 75°F (24°C).
3. Run the compressor at one of the speeds listed in the table below for 10-15 minutes.
4. While maintaining engine speed, turn off A/C system and immediately turn off engine.
5. Recover refrigerant from the system.
6. Remove compressor from vehicle.
7. Remove the oil plug and drain as much oil as possible into a suitable container.

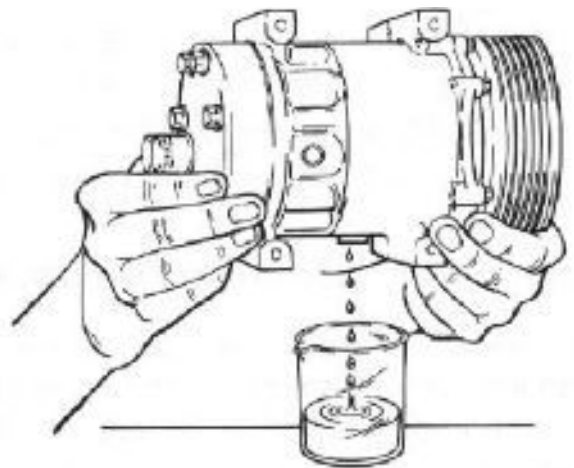

13.4.2 (Cont.)

8. Drain oil from the suction and discharge ports into a suitable container while turning the shaft clockwise only with a socket wrench on the armature retaining nut.
9. Measure and record the volume of the oil drained from the compressor.
10. Approximately 0.5 fl.oz. (15cc) will remain in the compressor as a film coating the internal surfaces. Add 0.5 fl.oz. (15cc) to the recorded volume of the oil. This is the calculated amount of oil in the compressor.



11. The amount of oil in the compressor after running for 10-15 minutes should be as per the table at right, if the proper amount of oil was in the system. Determine from the table what the correct amount of oil should be for the particular speed used in step 3. (The table shown applies to SD5H14 compressors. Other compressors will exhibit a lesser oil amount dependent upon type. It is important that a quantity of oil remains in the crankcase after the test.)

Comp. RPM	Oil in compressor	
	fl.oz	cc
1,000	3.4	100
2,000	2.5	75
3,000	1.7	50
4,000	1.3	40
5,000	1.2	35

- Vehicle doors open
- Maximum blower speed
- Ambient temperature at least 75°F

12. Compare the desired amount of oil as determined in step 11 with the calculated actual amount of oil in the compressor, which was determined in step 10. If the amount of oil actually in the compressor [amount drained plus 0.5 fl.oz. (15cc)] is less than the desired amount of oil, add oil as necessary to the container and pour back into the compressor. If the amount of oil actually in the compressor is too much, remove oil from the container until the correct amount is reached, and pour back into compressor. the amount of oil poured back into the compressor should equal the desired amount (from the table), minus 0.5 fl.oz. (15cc). Use the correct oil type as per Section 6.3.
13. Reinstall oil plug. Seal and O-ring must be clean and not damaged. Torque to 11-15 ft•lb (15-20 N•m, 150-200 kgf•cm).

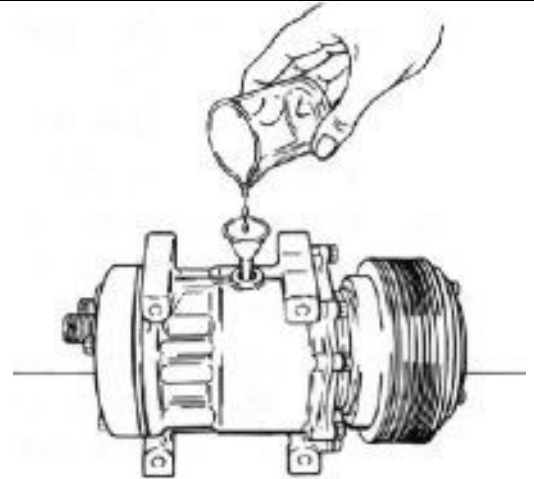

13.5 Oil Retained in System Components

For reference, the amount of oil typically retained in other system components after running at 100 rpm compressor speed is shown at right. These volumes will of course vary with different designs of the components and compressor speeds prior to shut down.

Component	Typical oil amount	
	fl. oz.	cc
Evaporator	2.0	60
Condenser	1.0	30
Receiver - Drier	0.5	15
Accumulator	2.0	60
Hoses (normal length)	0.3	10

SERVICE OPERATIONS - CLUTCH

14.1a Keyed Shaft Armature Removal

(Note: Keyed shaft can be identified in that the holes for the armature plate spanner will have threads in them.)

1. If armature dust cover is present, remove the 3 or 6 bolts holding it in place and remove cover. If auxilliary sheet metal pulley is present, remove the screws holding it in place. Then remove pulley.
2. Insert pins of armature plate spanner into threaded holes of armature assembly.
3. Hold armature assembly stationary while removing retaining nut with 3/4", 19mm or 14mm socket wrench, as appropriate.
4. Remove armature assembly using puller. Thread 3 puller bolts into the threaded holes in the armature assembly. Turn center screw clockwise until armature assembly comes loose.
5. If shims are above shaft key, remove them now. If shims are below shaft key, the key and bearing dust cover (if present) must be removed before shims can be removed.
6. Remove bearing dust cover (if present). Use caution to prevent distorting cover when removing it.
7. Remove shaft key by tapping loose with a flat blade screwdriver and hammer.
8. Remove shims. Use a pointed tool and a small screwdriver to prevent the shims from binding on the shaft.



14.1b Spline Shaft Armature Removal

(Note: Spline shaft can be identified in that the holes for the armature plate spanner will not have threads in them.)

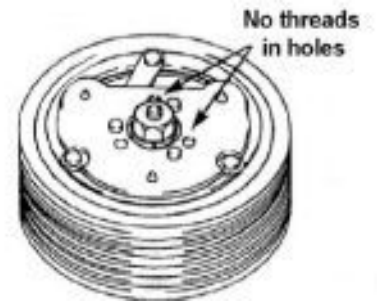

1. If armature dust cover is present, remove the 3 or 6 bolts holding it in place and remove cover. If auxillary sheet metal pulley is present, remove the screws holding it in place. Then remove pulley.
2. Insert pins of armature plate spanner into threaded holes of armature assembly.
3. Hold armature assembly stationary while removing retaining nut with 3/4", 19mm, or 14mm socket wrench, as appropriate.
4. Lift off armature plate with fingers. If armature does not come off easily, spray an anti seize oil into shaft to loosen. Armature plate can also be loosened by gently prying between rotor and armature plate with two flat screwdrivers.



5. If shims are above shaft key, remove shims. If shims are below shaft key, the key and bearing dust cover (if present) must be removed before the shims can be removed.
6. Remove bearing dust cover (if present). Use caution to prevent distorting cover when removing it.
7. Remove shims. Use a pointed tool and a small screwdriver to prevent the shims from binding on the shaft.



14.2 Rotor Assembly Removal

1. If bearing dust cover has not been removed, remove it now. See step 6 of Section 14.1, for Armature Assembly Removal.
2. If internal snap ring for bearing is visible above the bearing, remove it with internal snap ring pliers.
3. Remove rotor snap ring.
4. Remove shaft key.
5. Remove rotor pulley assembly:
 - Insert the lip of the jaws into the snap ring groove.
 - Place rotor pulley shaft protector (Puller set) over the exposed shaft.
 - Align thumb screws to puller jaws and finger tighten. Turn puller center bolt clockwise using a socket wrench until rotor pulley is free.

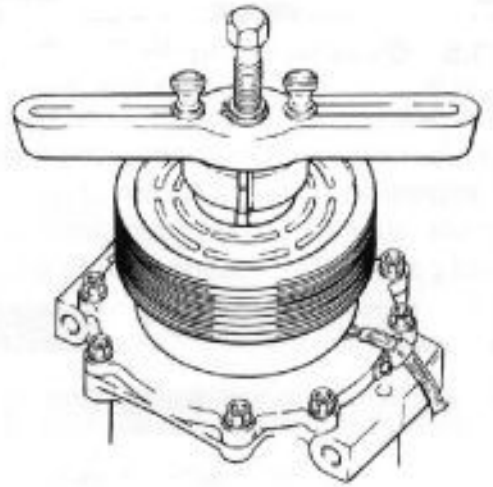

14.3 Field Coil Assembly Removal

1. Loosen lead wire clamp screw with #2 Phillips screwdriver until wire(s) can be slipped out from under clamp.
2. Undo any wire connections on the compressor which would prevent removal of the field coil assembly.
3. Remove snap ring.
4. Remove the field coil assembly.

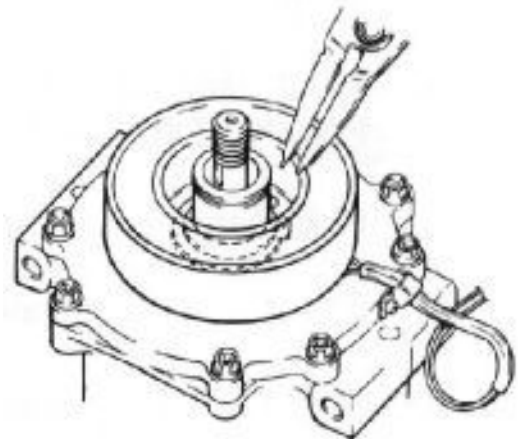

14.4 Field Coil Assembly Installation

Reverse the steps of Section 14.3. Protrusion on underside of coil ring must match hole in front housing to prevent movement and correctly locate lead wire(s).

14.5 Rotor Assembly Installation

1. Place compressor on support stand, supported at rear end of compressor. If the compressor must be clamped in a vise, clamp only on the mounting ears, never on the body of the compressor.
2. Set rotor squarely over the front housing boss.
3. Place the rotor installer ring into the bearing bore. Ensure that the edge rests only on the inner race of the bearing, not on the seal, pulley, or outer race of the bearing.
4. Place the driver into the ring and drive the rotor down onto the front housing with a hammer or arbor press. Drive the rotor against the front housing step. A distinct change of sound can be heard when using the hammer to install the rotor.
5. Reinstall rotor bearing snap ring, if it has been removed, with internal snap ring pliers.
6. Reinstall rotor retaining snap ring with external snap ring pliers. If a bevel is present on the snap ring, it should face up (away from the body of the compressor).
7. Reinstall rotor bearing dust cover (if present) by gently tapping it into place.

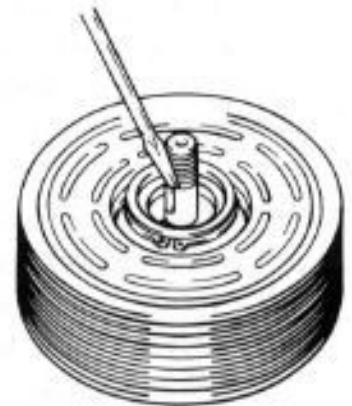

14.6 Armature Assembly Installation

1. Install shaft key with pliers.
2. Install clutch shims. NOTE: Clutch air gap is determined by shim thickness. When installing a clutch on a used compressor, try the original shims first. When installing a clutch on a compressor that has not had a clutch installed before, first try 0.04", 0.02", and 0.004" (1.0, 0.5, 0.1 mm) shims.



Sólo para eje con cuñero

14.6 (Cont.)

3. Align keyway in armature assembly to shaft key. Using driver and a hammer or arbor press, drive the armature assembly down over the shaft until it bottoms on the shims. A distinct sound change will be noted if driving with a hammer.

4. Replace retaining nut and torque to specification.

1/2-20: 20-25 ft•lb (27-34 N•m, 270-350 kg•cm)

M8: 11-15 ft•lb (15-21 N•m, 150-210 kgf•cm)

5. Check air gap with feeler gauge. Specification is 0.016" -0.031" (0.4 - 0.8mm). If gap is not even around the clutch, gently tap down at the high spots. If the overall gap is out of spec., remove the armature assembly and change the shims as necessary.

6. Replace armature dust cover (if used) and torque 3 or 6 bolts to specification below.

3 - 1/4-20 bolts (SD-5): 2-4 ft•lb (2-5 N•m, 25-50 kgf•cm)

6 - M5 bolts (SD-7): 5-8 ft•lb (7-11 N•m, 70-110 kgf•cm)

***Note: Over torque of SD508/SH14 dust cover bolts will cause air gap to become out of spec.**

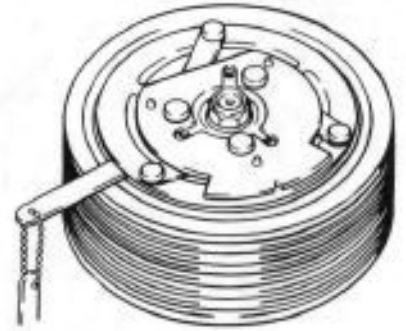
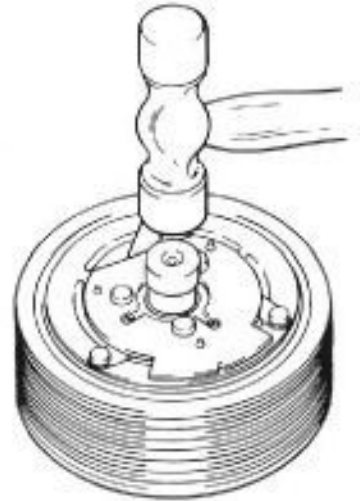

SERVICE OPERATIONS - SHAFT SEAL

15. Replacement of Lip Type Shaft Seal (SD5H14, SD7B10, SD7H13, SD7H15)

Note: Lip seal assembly and felt ring must never be reused. Always replace these components.

1. Be sure all gas pressure inside the compressor has been relieved.
2. Remove armature dust cover (if used), armature assembly, rotor bearing dust cover (if used), shaft key, and clutch shims as per section 14.1.
3. Insert the points of a pair of snap ring pliers into the holes of the felt ring retainer and pry out the retainer and felt ring.
4. Remove seal snap ring with internal snap ring pliers.

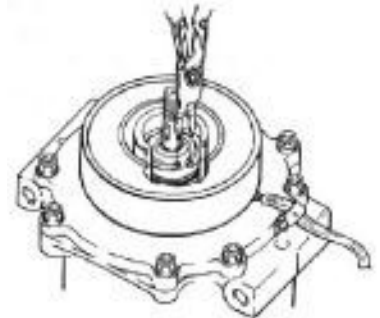
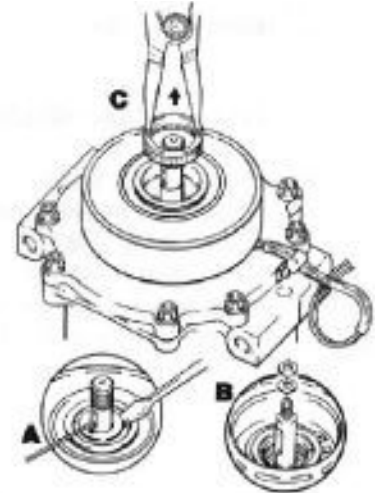

15. (Cont.)

5. Use lip seal removal and installation tool to remove lip seal assembly. Twist the tool until the 2 lips on the tool engage the slots in the lip seal housing and pull the seal out with a twisting motion.

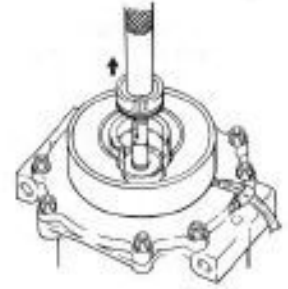

6. Clean out shaft seal cavity thoroughly. Debris can be removed using a non-petroleum based solvent and lint free cloth. The area should then be blown out with clean, dry compressed air. Make sure all foreign material is completely removed.

7. Place shaft seal protective sleeve over compressor shaft. Inspect the sleeve to ensure that it has no scratches and is smooth so that the lip seal will not be damaged. Make sure there is no gap between the end of the sleeve and the seal surface on the shaft.

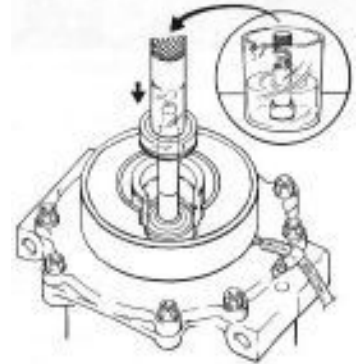

8. Engage the lips of the seal removal and installation tool with the slots in the new lip seal housing. Make sure the lip seal assembly, especially the O-ring, is clean. Dip the entire lip seal assembly, on the tool, into clean 5GS refrigerant oil. Make sure the seal assembly is completely covered with oil.

9. Install lip seal over shaft and press firmly to seat. Twist the tool in the opposite direction to disengage it from the seal and withdraw the tool.

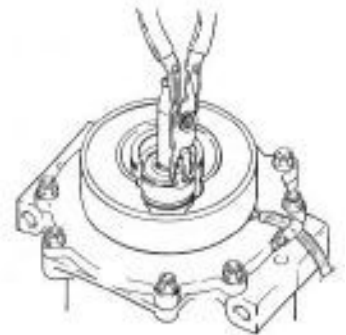

10. Reinstall shaft seal snap ring with internal snap ring pliers. Beveled side should face up (outward/away from compressor body). Ensure that snap ring is completely seated in groove. It may be necessary to tap the snap ring lightly to seat it in the groove.

11. Tap new felt ring assembly into place.

12. Reinstall clutch shims, shaft key, rotor bearing dust cover (if used), and armature assembly as described in Section 14.6

13. Check and adjust air gap as necessary as shown in Section 14.6.

14. Reinstall armature dust cover (if used) as described in Section 14.6.

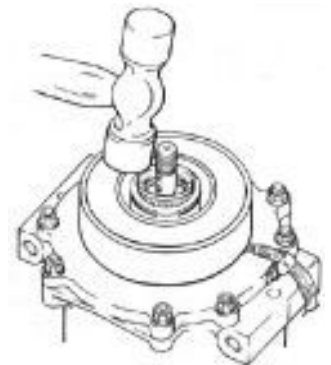

SERVICE OPERATIONS - CYLINDER HEAD / VALVE PLATE

16.1 Cylinder Head Removal

1. Be sure all internal compressor pressure has been relieved.
2. Inspect cylinder head for fitting or thread damage. Replace if damaged
3. Remove cylinder head bolts.
4. Use a small hammer and gasket scraper to separate the cylinder head from the valve plate. Be careful not to scratch the gasket surface of the cylinder head.
5. Carefully lift the cylinder head from the valve plate.
6. It is recommended that both the head gasket (between the cylinder head and the valve plate) and the block gasket (between the valve plate and the cylinder block) be replaced any time the cylinder head is removed. However, if no service is required to the valve plate, it may be left in place. If the valve plate comes loose from the cylinder block, the block gasket must be replaced.
7. Carefully remove old head gasket from top of valve plate with gasket scraper. Be careful not to disturb the valve plate to cylinder block joint if valve plate has been left in place. If valve plate comes loose from cylinder block, proceed to Section 16.2, Valve Plate Removal, and replace block gasket.

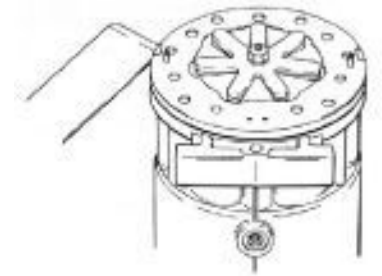
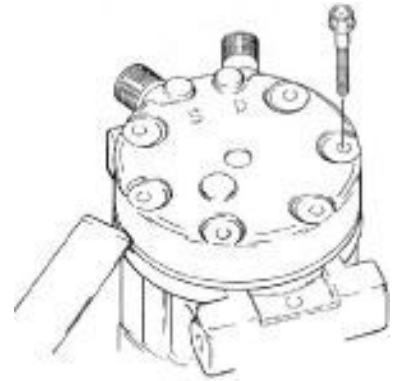

16.2 Valve Plate Removal

1. Using a small hammer and gasket scraper, carefully separate valve plate from cylinder block. **Be careful not to damage sealing surface of cylinder block.**
2. Inspect reed valves and retainer. Replace valve plate assembly if any part is damaged.
3. Carefully remove any gasket material remaining on valve plate, cylinder block or cylinder head. Do not damage sealing surfaces on components.

16.3 Valve Plate and Cylinder Head Installation

1. Large gasket: OD of block gasket is 4-3/4" (120mm) and sealing face of block does not have a 4-1/2" (114.7mm) diameter step.
2. Small gasket: OD of gasket is 4-1/2" (114.7mm) and sealing face of the cylinder block has a 4-1/2" (114.7mm) diameter step.
3. Coat new block gasket with clean 5GS refrigerant oil.
4. Install block gasket. Align new gasket to location pin holes and orifice(s). Notch (if present) should face same direction as oil plug or adapter.
5. Place valve plate on cylinder block with discharge valve, retainer and nut facing up (away from cylinder block) and location pins properly located in holes.
6. Use vacuum pump and small tube to remove residual oil from each bolt hole. If this step is not performed, hydraulic pressure can be created when the cylinder head bolts are tightened. This pressure can break the cylinder block.
7. Coat head gasket with clean 5GS refrigerant oil.
8. Install head gasket cover location pins, checking for correct orientation.
9. Install cylinder head.
10. Install cylinder head bolts and tighten in a star pattern. Torque first to approximately 14 ft•lbf (19.6 N•m, 200 kgf•cm), then finish by torquing to 24-27 ft•lbf (32.4-36.3 N•m, 330-370kgf•cm).

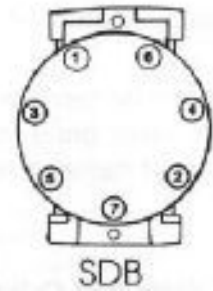
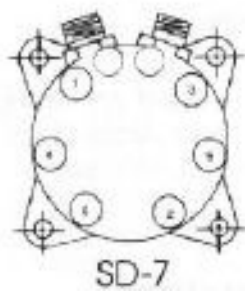
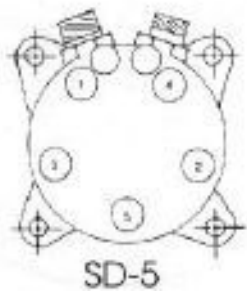
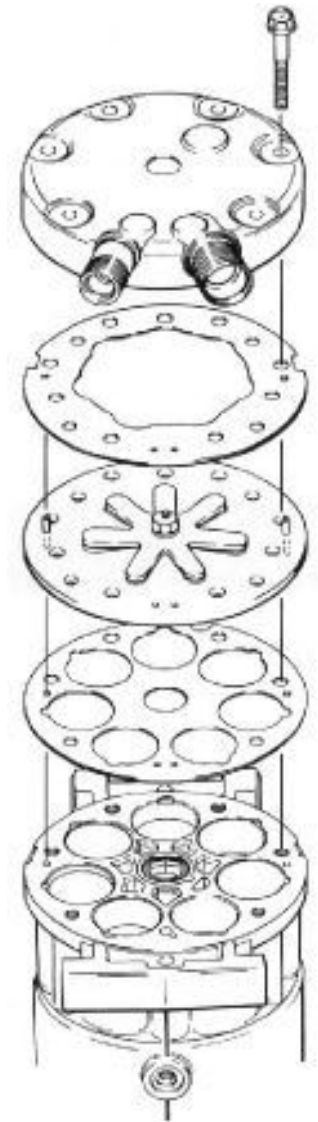

SERVICE OPERATIONS - THERMAL PROTECTOR SWITCH

17.1 TPS Testing

Some models of SD compressors are equipped with a bi-metal type thermal protector switch (TPS) to protect against abnormally high temperatures. Contact Sanden Application Engineering for additional information.

1. Check continuity at room temperature. If switch is open at room temperature, remove and replace.
2. Check actuating temperature. Remove TPS and place in container of PAG oil. Heat oil using an electric hot plate while monitoring oil temperature. TPS should open at $116 \pm 5^{\circ}\text{C}$ ($241 \pm 9^{\circ}\text{F}$). If it does not function properly, replace it.

17.2 TPS Replacement

1. Disconnect all electrical connections.
2. Remove TPS retaining clip bolt.
3. Spray around TPS with commercial non-petroleum based solvent (volatile type such as 1,1,1-trichloroethane or approved substitute), to loosen silicone.
4. Remove TPS with pliers. Use care to prevent deforming the TPS housing because this can change the temperature setting.
5. Clean silicone out of TPS well with flat bladed screwdriver. Wipe out the TPS well with a cloth. Make sure well area is clean and dry.
6. Apply a dot of silicone RTV (Dow Corning #8390 or 1340 recommended) approximately 1/4" (6mm) in diameter and 1/8" (3mm) high at the bottom of the TPS well.
7. Install TPS, making sure lead wires are oriented to the clearance notch.
8. Install TPS retaining clip and bolt. Hold clip tight against stop while torquing bolt to 6-9 ft•lb (8-13 N•m, 80-130 kgf•cm)
9. Reconnect electrical connections and check function.

SERVICE OPERATIONS - HIGH PRESSURE RELIEF VALVE

18. HPRV Replacement

Some models of Sanden compressors are fitted with a high pressure relief valve (HPRV) to protect against damage from abnormally high discharge pressures.

1. **Note:** When replacing a failed HPRV with a new one, be sure to identify whether the A/C system is for R-12 or R134a. The HPRV and the small O-ring at the threaded portion are both different for R134a. Contact your supplier for additional information.
2. Be sure all gas pressure has been released from inside the compressor.
3. Remove HPRV.
4. Coat O-ring of a new HPRV with clean 5GS refrigerant oil. Seat and O-ring must be clean and not damaged.
5. Install new HPRV and torque to 6-9 ft•lb (8-12 N•m, 80-120 kgf•cm).

CONVERTING R-12 SYSTEMS TO R134a

19.1 Recommended Procedures for Sanden R-12 Compressors Retrofitted with R134a

The use of R134a in mobile A/C systems designed for R-12 refrigerant use causes higher discharge pressures (as much as 10-15%) and necessitates changing the compressor lubricant from mineral oil (5GS) to PAG oil (Sanden's SP-10 or SP-20) to ensure compatibility.

These changes result in greater wear to the internal components of the compressor. Therefore, to ensure consistent and expected reliability, Sanden does not recommend using R134a in systems and compressors designed for R-12.

However

Sanden recognizes the realities of the automotive service markets and consumer preferences. If a retrofit is required, please follow the vehicle manufacturer's published retrofit procedures. Ensure all work done complies with SAE recommended practices as described in J1660 & J1661:

- Repair any problems or leaks before retrofitting.
- Affix labels to the vehicle showing conversion status.
- Observe all safety recommendations.

If an OEM retrofit procedure is not available, Sanden recommends the following procedure:

19.2 Sanden's Procedure for Conversion from R-12 to R134a

1. If the R-12 vehicle air conditioning system is optional, run it at idle with the A/C blower on high speed for five (5) minutes to maximize the amount of oil in the compressor.
2. Recover all R-12 refrigerant from the vehicle's A/C system.
3. Remove the compressor from the vehicle.
4. Remove the compressor oil plug and then drain as much mineral oil as possible from the compressor body.
5. Drain mineral oil from the cylinder head suction and discharge ports while turning the shaft with a socket wrench on the clutch armature retaining nut.
6. Remove the existing R-12 receiver-drier or accumulator-drier from the vehicle and discard. Allow as much oil as possible to drain from the A/C hoses.
7. Change any O-rings on the receiver-drier or accumulator-drier joints to approved HNBR O-rings; replace any other O-rings that have been disturbed.
8. Replace the receiver-drier or accumulator-drier with a new R134a compatible one containing XH7 or XH9 desiccant.
9. If a CCOT system is being repaired due to compressor damage, or foreign material is found in the oil drained from the system, this foreign material must be removed from the system. At this time an in-line filter should be installed in the liquid line. Allow as much oil as possible to drain from the A/C lines when installing the filter. Change any O-rings disturbed in the installation of the filter to approved HBNR O-rings.
10. Perform any necessary repairs to the compressor or A/C systems.
11. Using the original refrigerant oil quantity specification, add SP-20 or SP-10 oil to the compressor (SP-10 for TR, SDV-710, SDB-705, SDB-706 and SDB-709; SP-20 for all other SD compressors).
12. Replace the compressor oil plug O-ring with an HNBR O-ring.
13. Reinstall the compressor oil plug. The plug seat and O-ring must be clean and free of damage. Torque the plug to 11-15 ft•lb (15-20 N•m, 150-200 kgf•cm)

19.2 (Cont.)

14. Change any seals at the compressor ports to approved HNBR seals.
15. Reinstall the compressor to the A/C system. Evacuate the A/C system for at least forty-five (45) minutes to a vacuum of 29 in. Hg, using R-12 equipment, to remove as much R-12 as possible from the residual mineral oil.
16. Remove all R-12 service equipment and disable the R-12 service fittings to prevent any refrigerant other than R134a from being used. Permanently install R134a quick connect service fittings to the A/C system.
17. Connect R134a service hoses and other equipment. Re-evacuate the system for thirty (30) minutes using the R134a equipment.
18. Charge the A/C system with R134a. Generally, about 5% (by weight) less than the R-12 charge amount is required. Leak check the system per SAE J1628 procedure.
19. If the A/C system is a CCOT type, which has been repaired due to damage or the discovery of foreign material in the oil drained from the system, run the system for sixty (60) minutes to capture this material in the filter installed in step 9. Recover the refrigerant, remove and dispose of the filter, reconnect the lines, evacuate for at least forty-five (45) minutes, and recharge the A/C system. This step should not be necessary for TXV systems, since the drier is fitted with an internal filter.
20. Check the A/C system operating parameters. The system should function correctly within acceptable limits of temperatures and pressures. This will ensure that the correct amount of R134a has been charged.
21. In extreme circumstances when expected cooling performance cannot be achieved and high discharge pressures are experienced, it may be necessary to add more condensing capacity to the A/C system. An electric fan(s) and/or larger capacity condenser can be used.
22. Replace all R-12 compressor labels with retrofit labels per SAE J1660 in order to provide information on the R134a retrofit which has been performed.

Model	Retrofit PAG oil amount fluid ounces (cc)	
	Expansion valve systems	Orifice tube systems
SD-505	3.4±0.5 (100±15)	No Standard
SD-507	5.5±0.5 (165±15)	No Standard
SD-508	7.2±0.5 (210±15)	9.5±0.5 (280±15)
SD-510	No Standard	8.1±0.5 (240±15)
SDB-706	No Standard	No Standard
SD-708	4.6±0.5 (135±15)	No Standard
SD-709	4.6±0.5 (135±15)	8.1±0.5 (240±15)



Sanden SP-20 REFRIGERANT OIL FOR R134a SD COMPRESSORS

Sanden provides field service containers of SP-20 PAG oil for Sanden SD-series compressors in convenient 250cc cans. These cans are designed to withstand moisture ingestion. Always keep the cap of the can tightly closed when not handling the oil.

Cans are packed in "six-packs" and available through your Sanden representative. Material safety data is also available.

Sanden limits the warranty of SD compressors for field service with the condition that only Sanden-approved SP-20 is utilized.

"Six-Pack" of 250 cc cans of SP-20 oil -Sanden Number 7803-1997.