



DE LOREAN MOTOR COMPANY

SERVICE BULLETIN

NUMBER ST-33-12/81

CATEGORY: TECHNICAL

ATTENTION: ALL DMC DEALERS/SERVICE MANAGERS

SUBJECT: WATER LEAKS - BODY

Water leaks into the interior of the vehicle body may be difficult to diagnose, and the following main points must be considered when a water leak occurs.

Does the leak occur with the vehicle in motion or standing still?

With the vehicle in motion, a water leak in the interior may be related to a much lower or distant entry point on the exterior due to the fact that a lower air pressure may exist in the interior than the exterior of the vehicle and equalized airflow may transport water to distant exit points in the interior. Splash water from the wheels may have an outside entry on the underside of the vehicle. Water leaks that occur with the vehicle standing still usually appear at a lower point in the interior.

Tilt of Vehicle

Some leaks may occur only with the vehicle in a tilted position causing designed drains to back up especially if large amounts of water are involved.

High Water Pressure

During washing or windstorms high water pressure may force water through seals and crevices or cause drains to back up and overflow.

Drains

Certain vehicle areas have designed drains to direct water to the outside. For example, drains are found on the bottom of the doors or around the door openings of the body to allow water that entered at the window lip seals, which due to their function cannot provide a full seal, to escape to the outside. Water entering through the gap of the doors is drained to the outside. Due to their function, all drains must be free of obstruction and seals (watertight) from the rest of the body.

Sealing

The joints of the body panels, windows, ducts and cable passages are sealed in areas where water entering at these points would drain to the inside.

Continued...

Issued 12/23/81

ST-33-12/81

Water Leaks - Body

Page 2

Owner observations and thorough knowledge of vehicle sealing and draining areas will greatly assist in locating a water leak.

The attachment to this bulletin identifies sealed joints of the DMC vehicle body.

When sealing the indicated joints use Dow Silastic 732 R.T.V. or equivalent.



William A. Charles
Director, Service/Parts

WAC:ak

Attachment

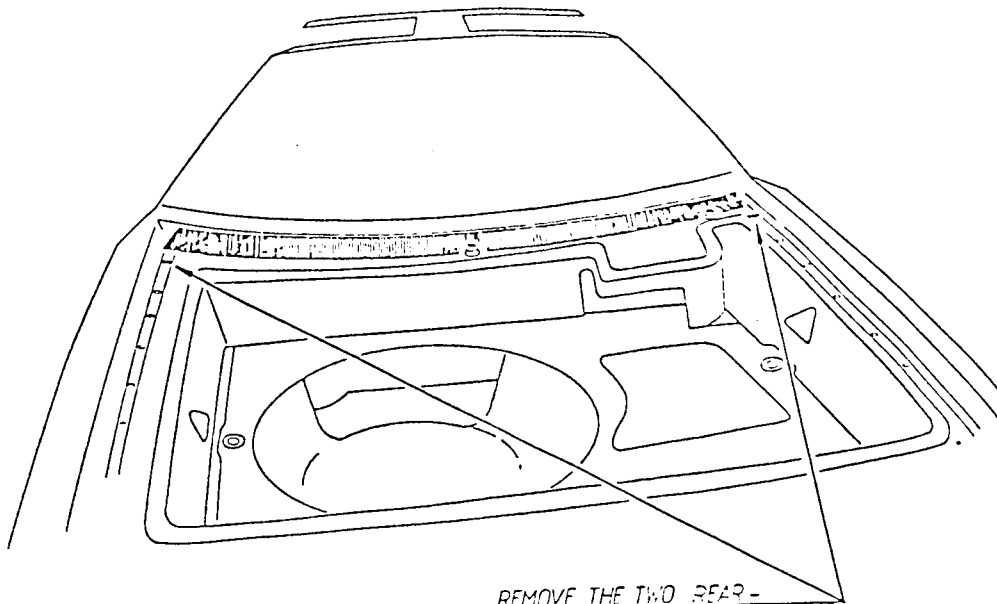

REMOVE THE TWO REAR-
MOST ATTACHMENT BOLTS OF
FRONT FENDERS & PLUS RIVNUT
WITH SILASTIC & REFIT ATTACHMENT BOLTS

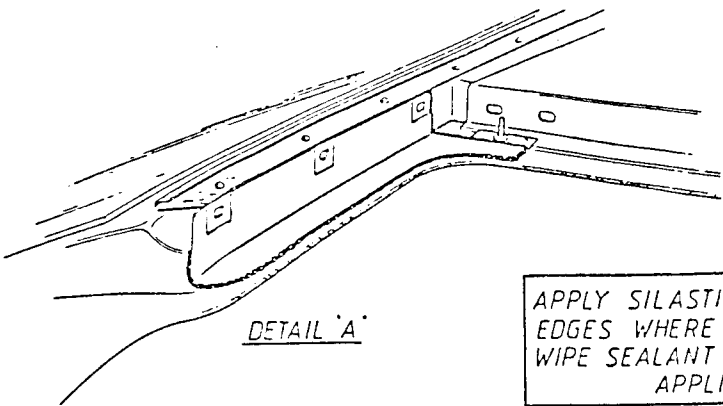

DETAIL 'A'

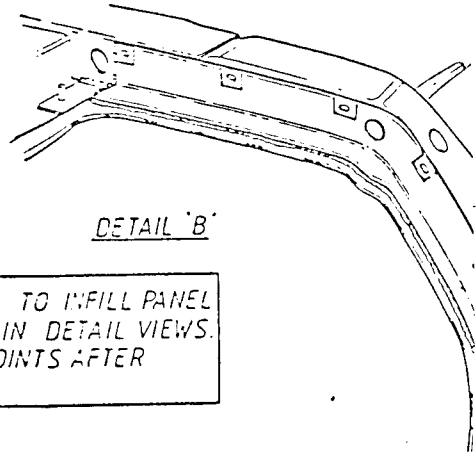

DETAIL 'B'

APPLY SILASTIC BEAD TO INFILL PANEL
EDGES WHERE SHOWN IN DETAIL VIEWS.
WIPE SEALANT INTO JOINTS AFTER
APPLICATION.

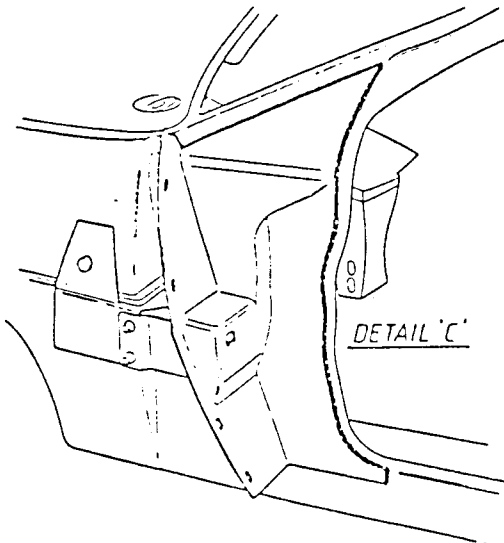

DETAIL 'C'

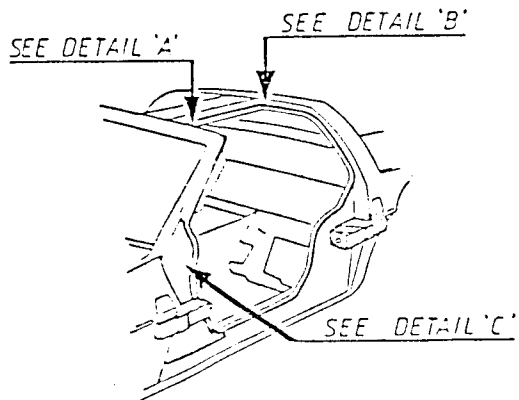

SEE DETAIL 'A'

SEE DETAIL 'B'

SEE DETAIL 'C'

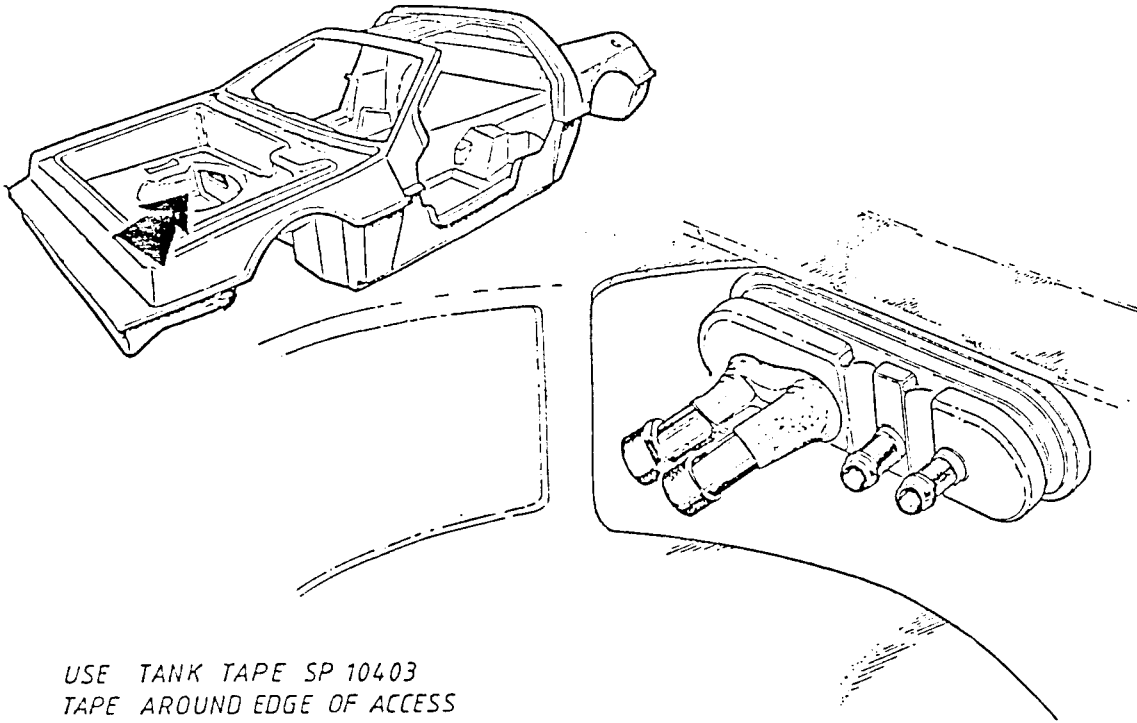

USE TANK TAPE SP 10403
TAPE AROUND EDGE OF ACCESS
HOLE FOR A.C. PIPES LEAVING
SUFFICIENT SLACK BETWEEN
PIPES TO ALLOW TAPE TO BE
PUSHED THROUGH AND STUCK
TO ITSELF. PRESS TAPE FIRMLY
AROUND PIPES.

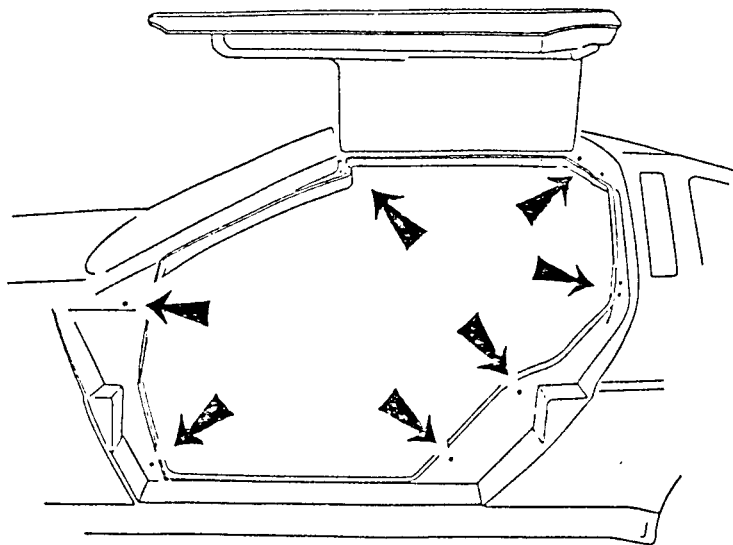

REMOVE SELF TAPPERS FROM INFILL PANELS
AND SEAL HOLES WITH SLASTIC REFIT SCREWS

SEAL TOP TO BOTTOM
SHELL JOINT LINE INSIDE
HOOD AREA
WIPE SILASTIC INTO
JOINT LINE

REMOVE SCREWS AND
FILL RIVNUTS WITH SILASTIC
AND REFIT SCREWS.
APPLY BEAD OF SILASTIC
AROUND PANEL EDGES AND
WIPE INTO JOINT.

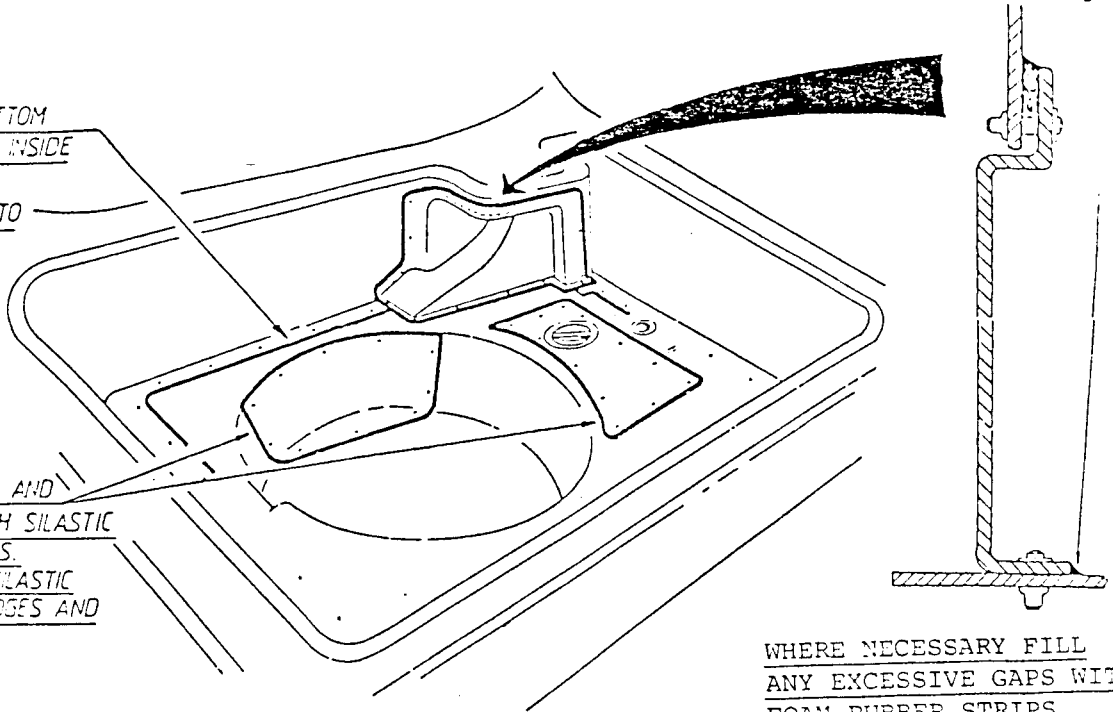

WHERE NECESSARY FILL
ANY EXCESSIVE GAPS WITH
FOAM RUBBER STRIPS
BEFORE SEALING WITH A
BEAD OF SILASTIC

SEAL MATING FACE OF PEDAL
BOX WITH BEAD OF SEALANT
IMMEDIATELY BEFORE MOUNTING
TO CAR, USING DOW SILASTIC
RTV SEALANT.

CLUTCH CYLINDER MOUNTING AREA MUST
BE KEPT FREE OF SEALANT.

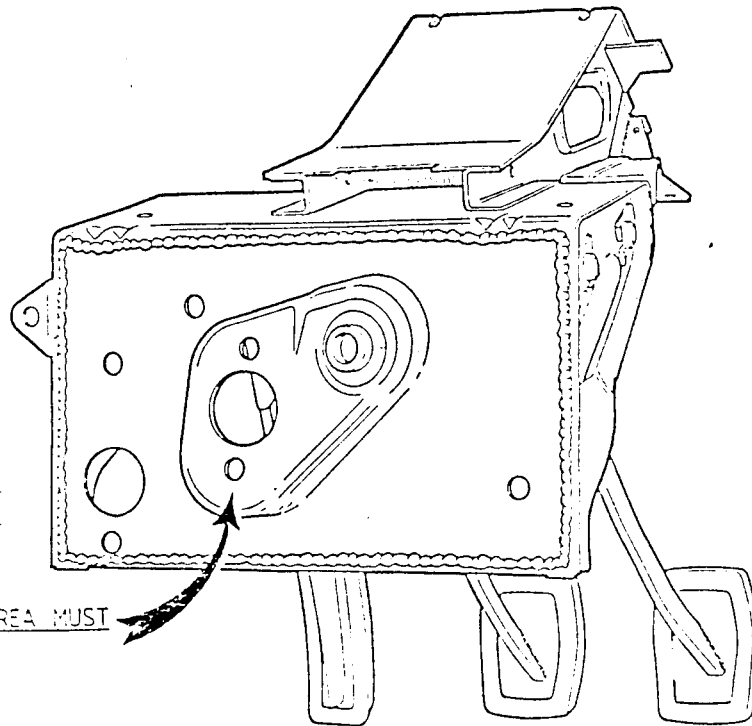

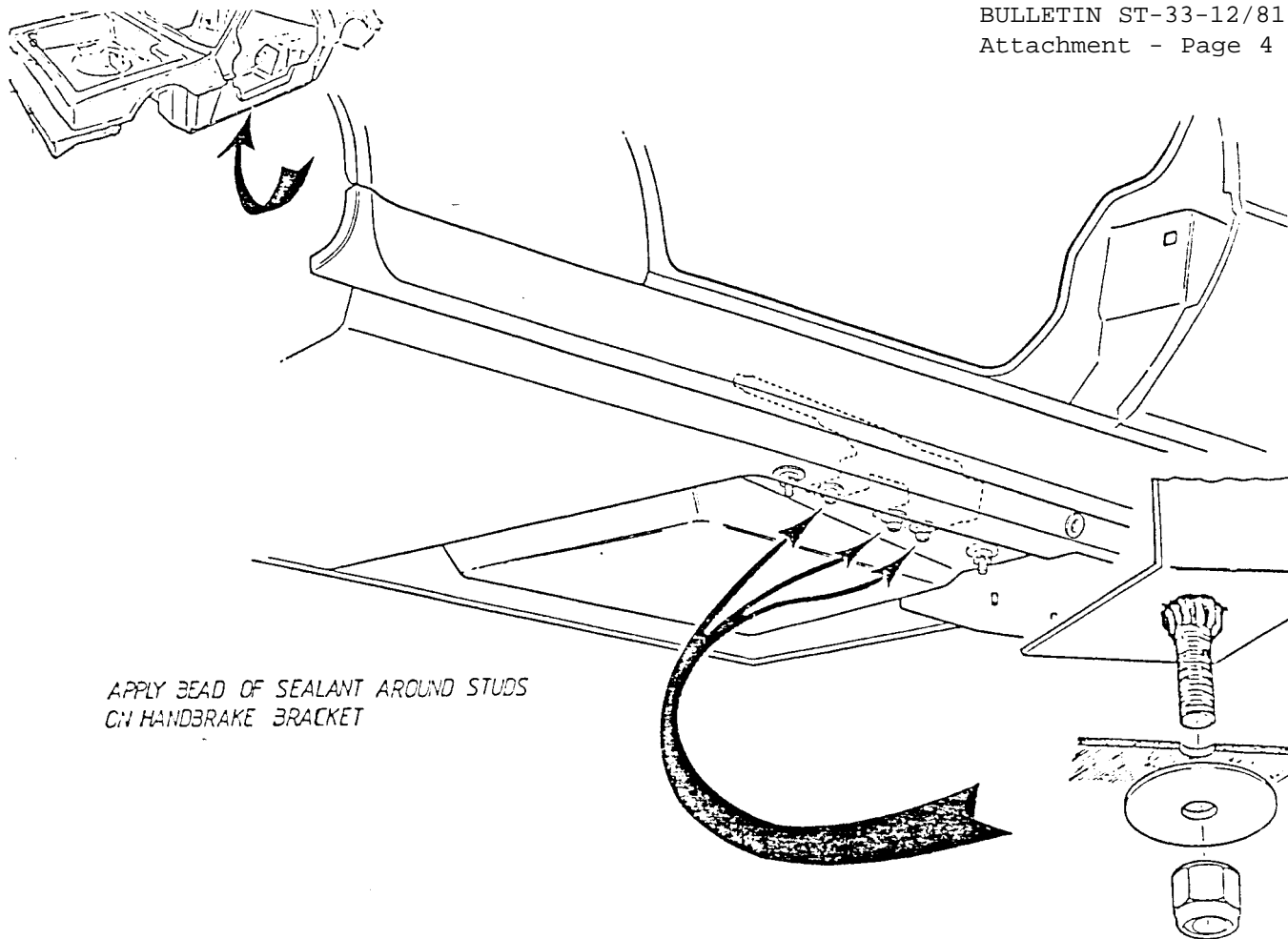

APPLY BEAD OF SEALANT AROUND STUDS
ON HANDBRAKE BRACKET

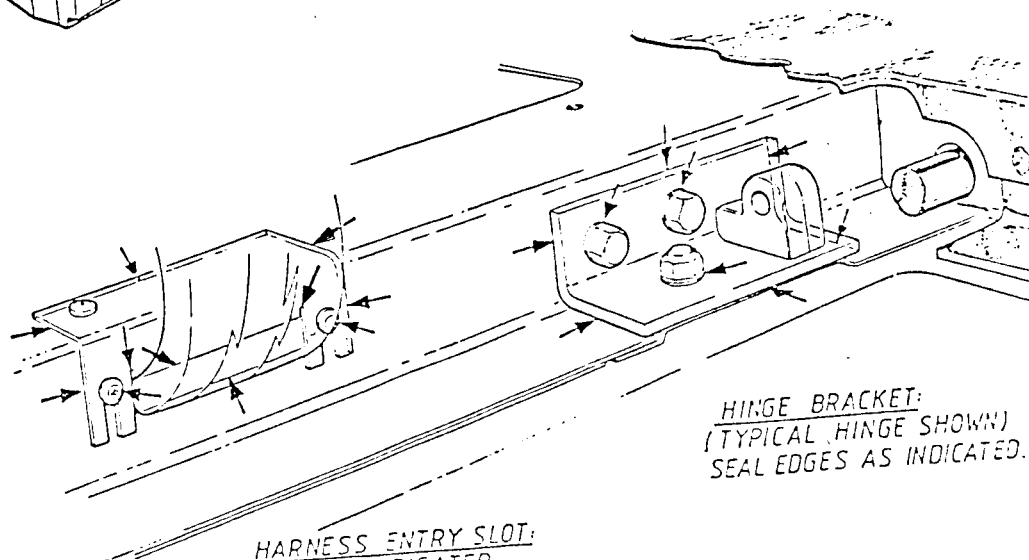
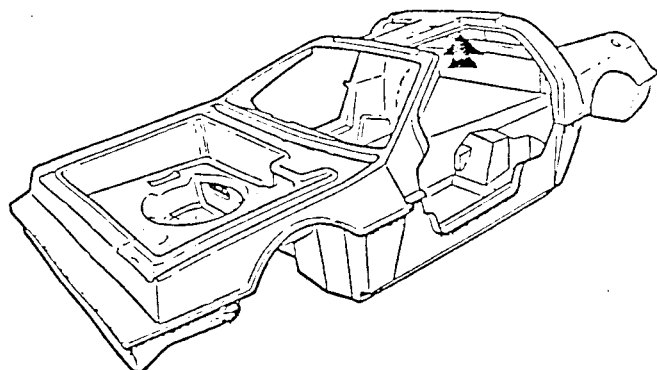

HARNESSE ENTRY SLOT:
SEAL AS INDICATED.
WIPE BEADS INTO JOINTS
ENSURE FOAM STRIPS
HAVE BEEN FITTED.

HINGE BRACKET:
(TYPICAL HINGE SHOWN)
SEAL EDGES AS INDICATED.

NOTE:
TORSION BAR, HINGE AND
DOOR EDGES OMITTED
FOR CLARITY.

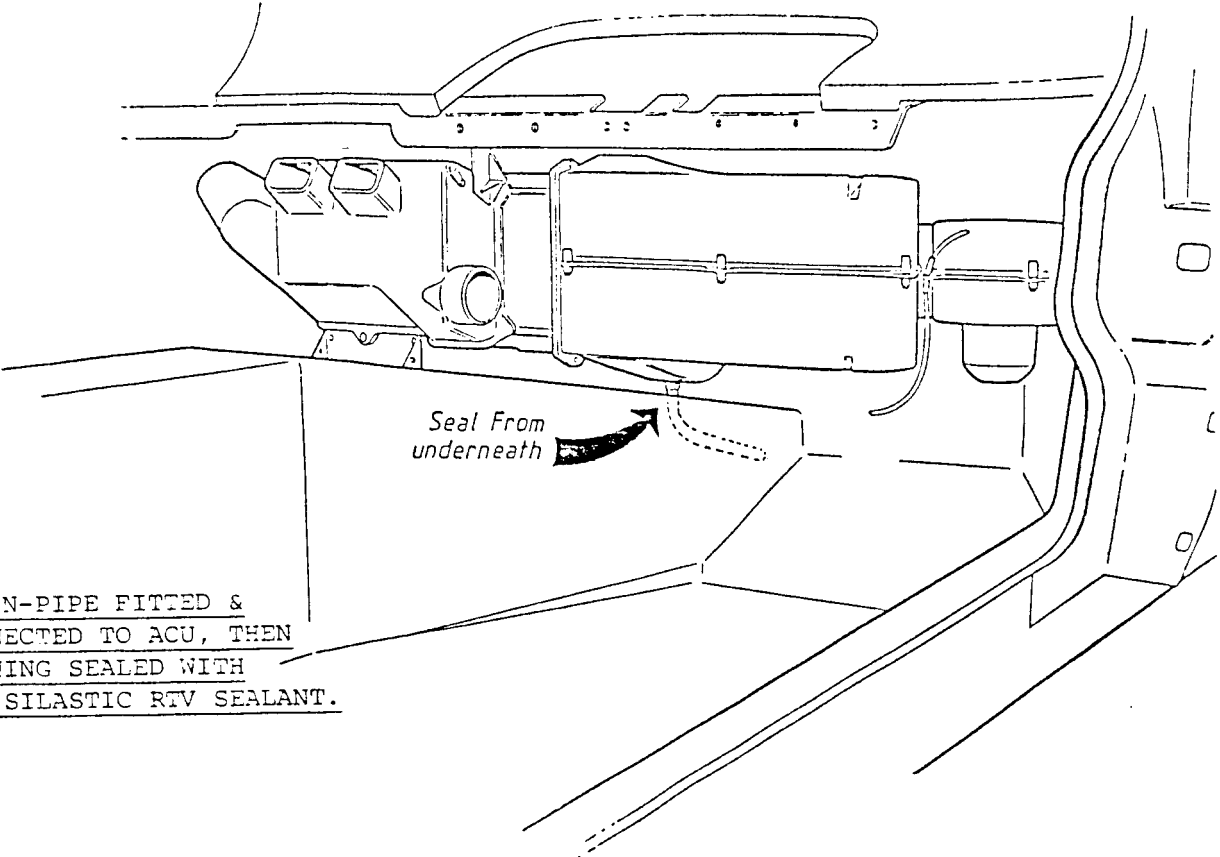

DRAIN-PIPE FITTED &
CONNECTED TO ACU, THEN
OPENING SEALED WITH
DOW SILASTIC RTV SEALANT.

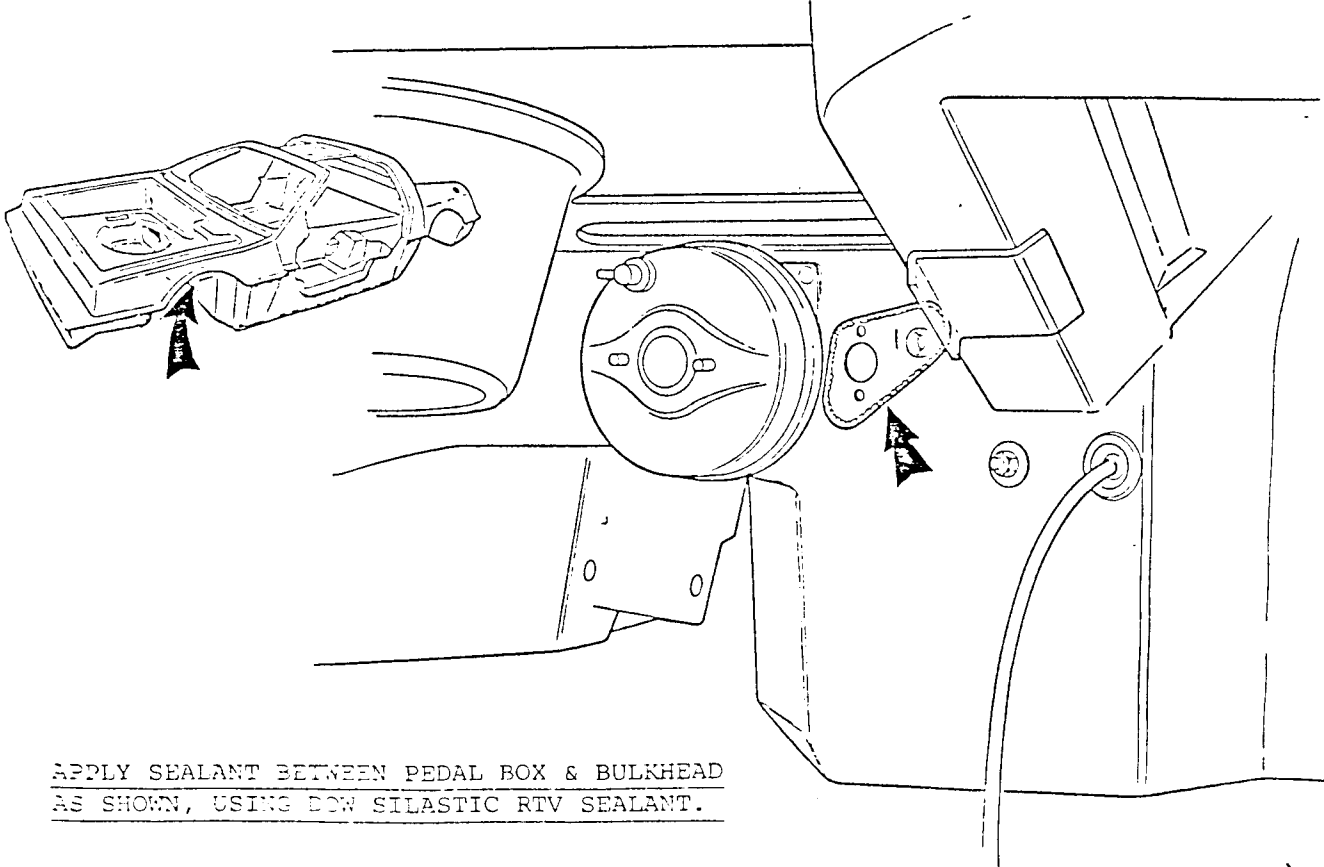

APPLY SEALANT BETWEEN PEDAL BOX & BULKHEAD
AS SHOWN, USING DOW SILASTIC RTV SEALANT.

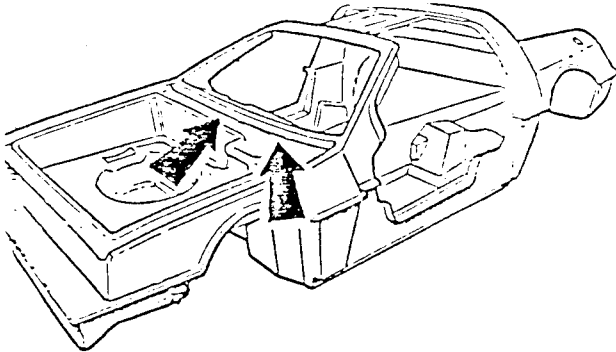

APPLY SILASTIC BEAD TO BODY
AROUND WIPER STEM - FIT RUBBER
WASHER - APPLY SECOND BEAD OF
SILASTIC TO WASHER - ASSEMBLE
AS NORMAL

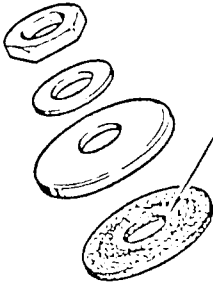

2nd SEALANT BEAD APPLIED AROUND HERE
AFTER FITTING RUBBER WASHER IN PLACE.

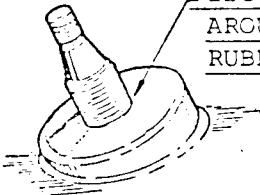

1st SEALANT BEAD APPLIED
AROUND HERE BEFORE FITTING
RUBBER WASHER IN PLACE.

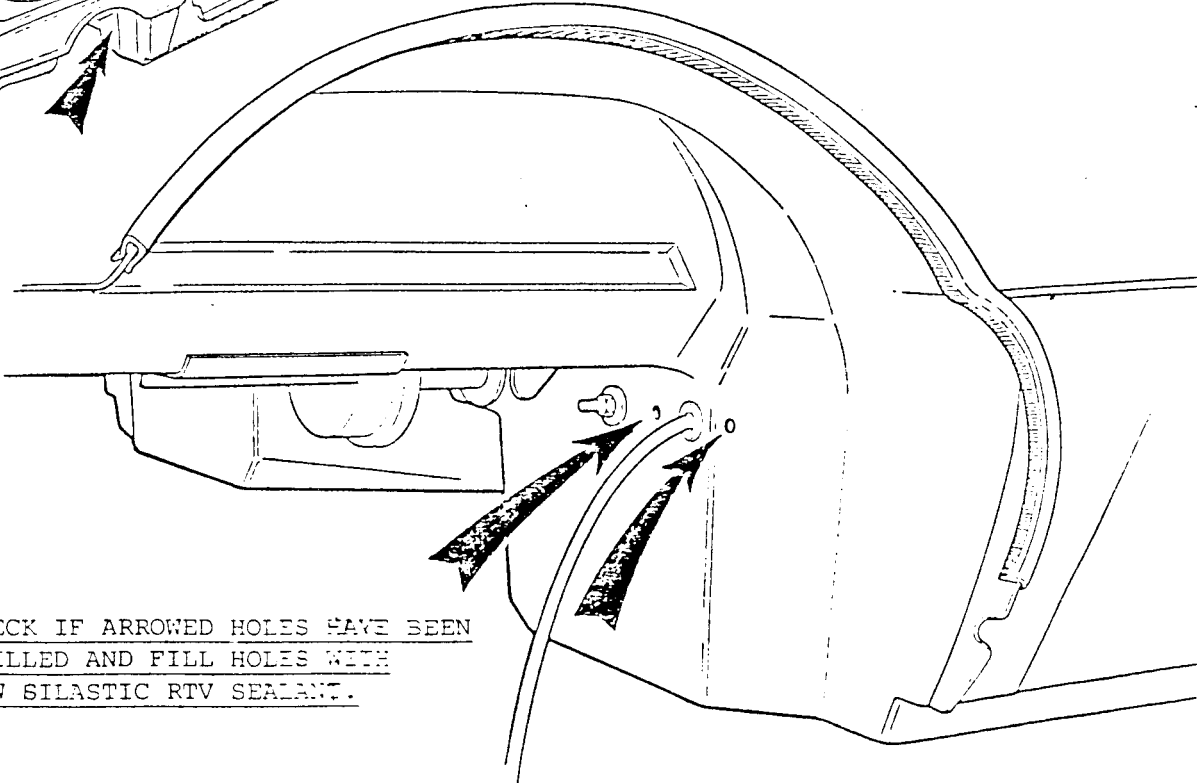
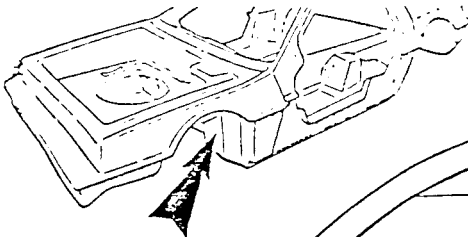

CHECK IF ARROWED HOLES HAVE BEEN
DRILLED AND FILL HOLES WITH
DOW SILASTIC RTV SEALANT.

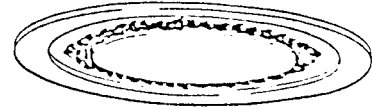

FOUR OFF BIG HEAD BOLTS
IN ROOF AREA SEALED AS
SHOWN WITH DOW SILASTIC RTV
SEALANT.

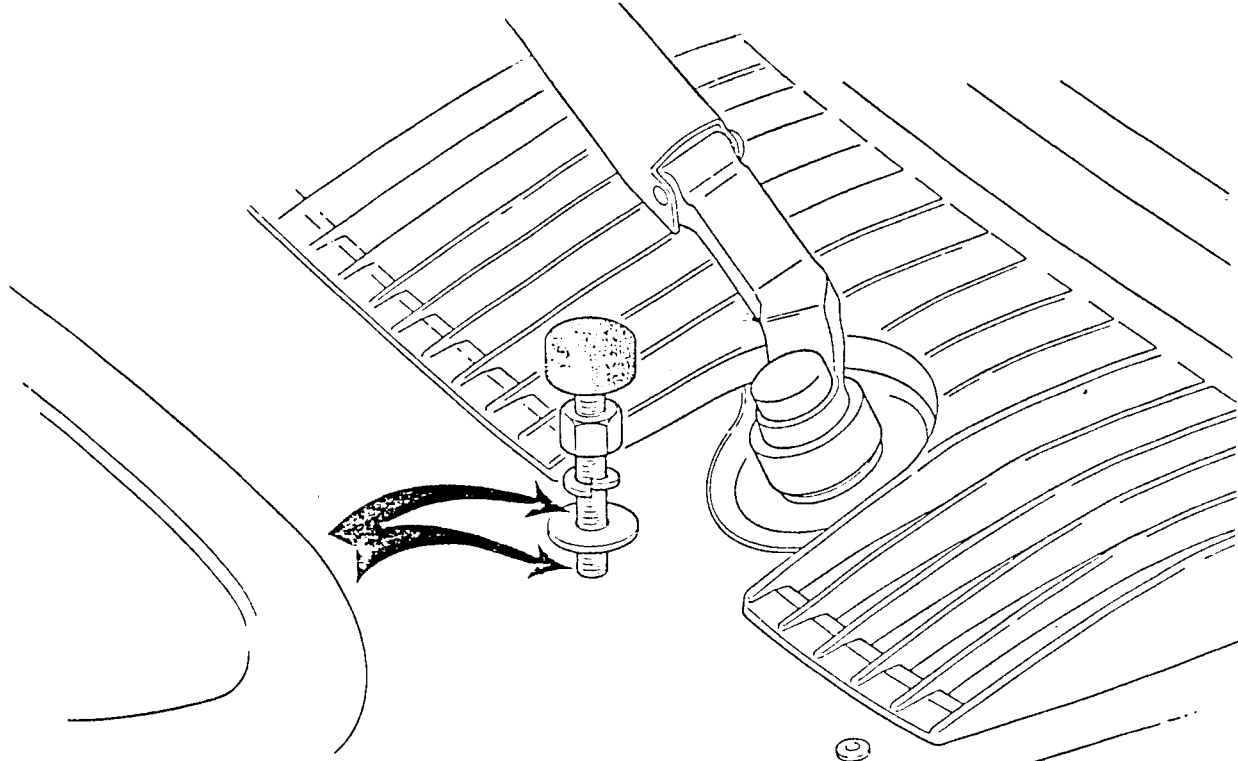
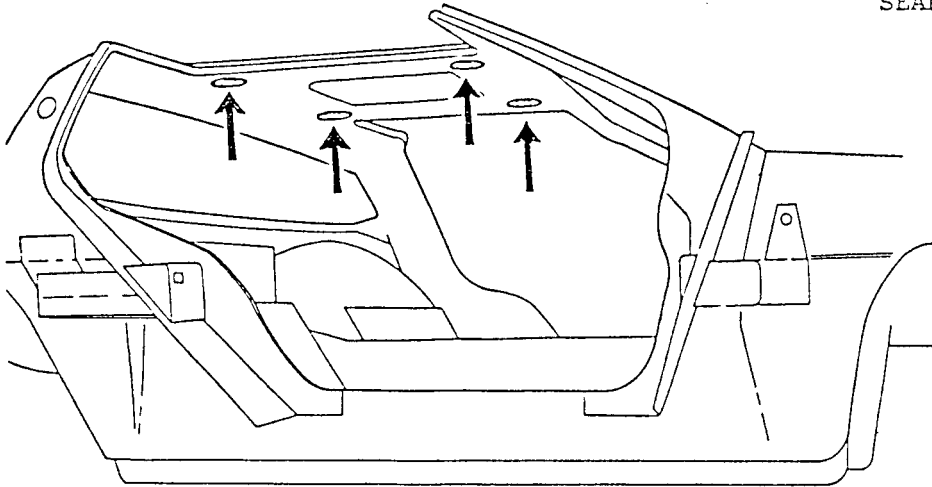

HOOD BUMP STOPS :
UNSCREW TOP NUT, LIFT WASHER & APPLY BLACK SILASTIC
SEALANT ABOVE AND BELOW THE WASHER. RETIGHTEN THE
TOP NUT. WIPE OFF EXCESS SEALANT.
THE ADJUSTMENT OF THE BUMP STOP MUST NOT BE UPSET,
AS THE BOTTOM NUT IS LOCKED ON.

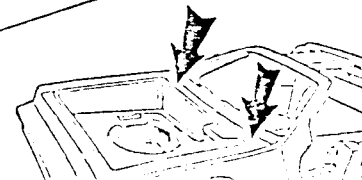

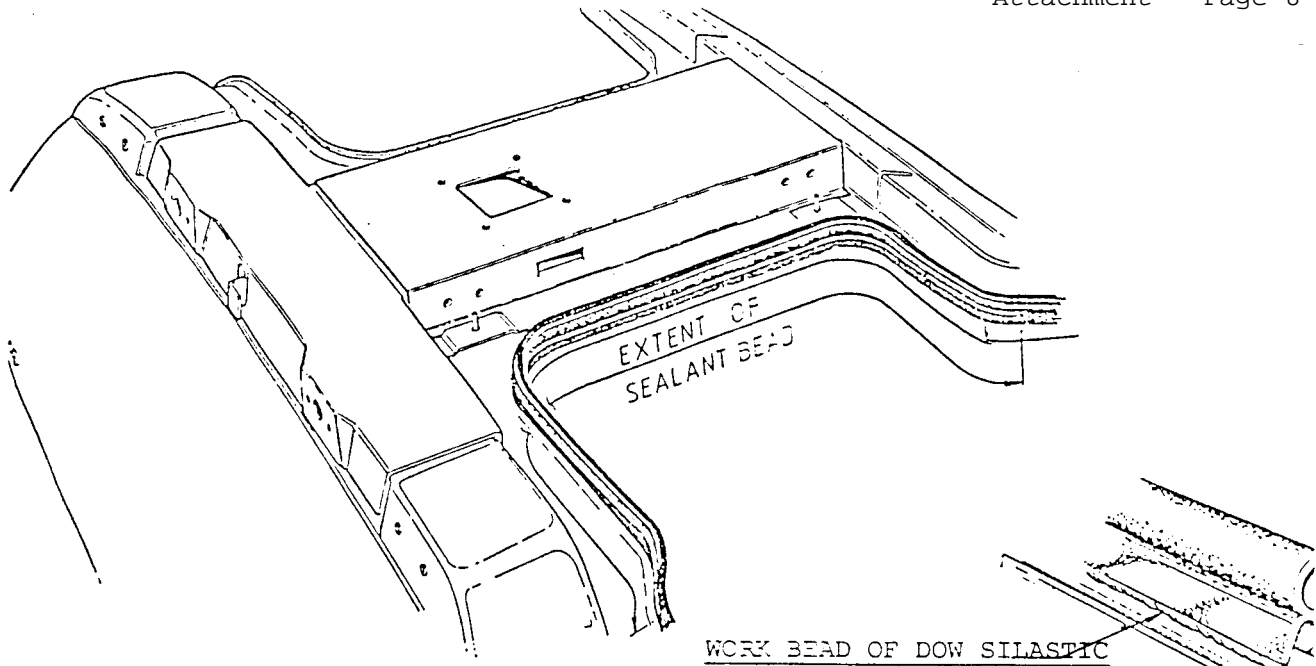

WORK BEAD OF DOW SILASTIC
RTV INTO PRIMARY SEAL/BODY
FLANGE EXTERIOR JOINT. EXTENT
OF APPLICATION SHOWN ABOVE.

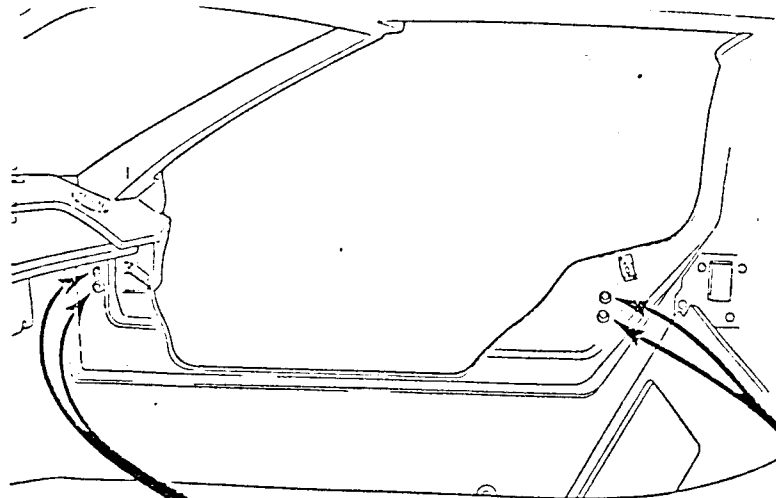

ACCESS HOLES IN FRONT
RECESS PANEL AREA:
APPLY SEALANT AROUND
BOLT HEADS, USING
DOW SILASTIC RTV
SEALANT.

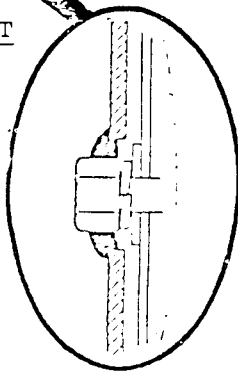

ACCESS HOLES IN REAR RECESS
PANELS:
TAPE OVER ACCESS HOLES
USING TANK TAPE SP 10403

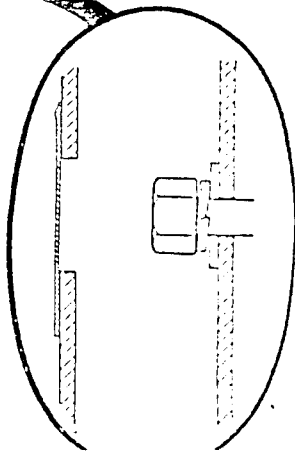

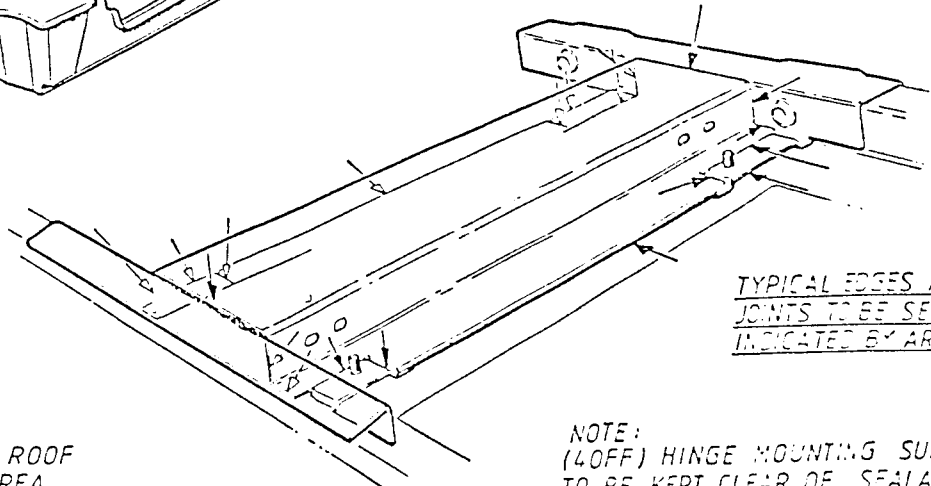
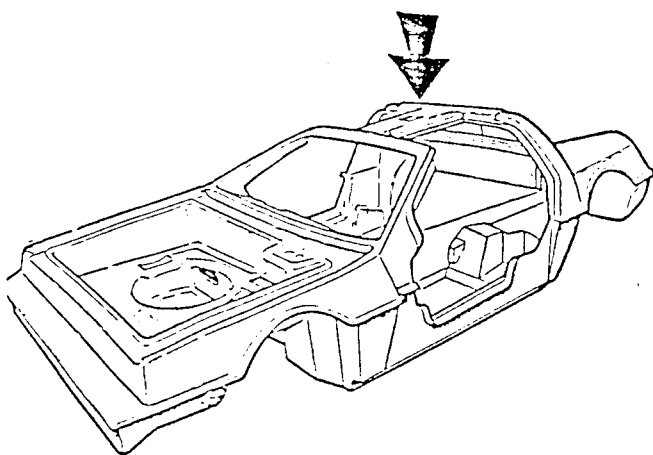

TYPICAL EDGES AND JOINTS TO BE SEALED INDICATED BY ARROWS

COMPLETELY SEAL ROOF REINFORCEMENT AREA.
SEALANT TO BE USED IS RTV 732 SILASTIC.
SEALANT BEAD TO BE 'WIPED' INTO JOINT AFTER APPLICATION.

NOTE:
(4OFF) HINGE MOUNTING SURFACES TO BE KEPT CLEAR OF SEALANT.

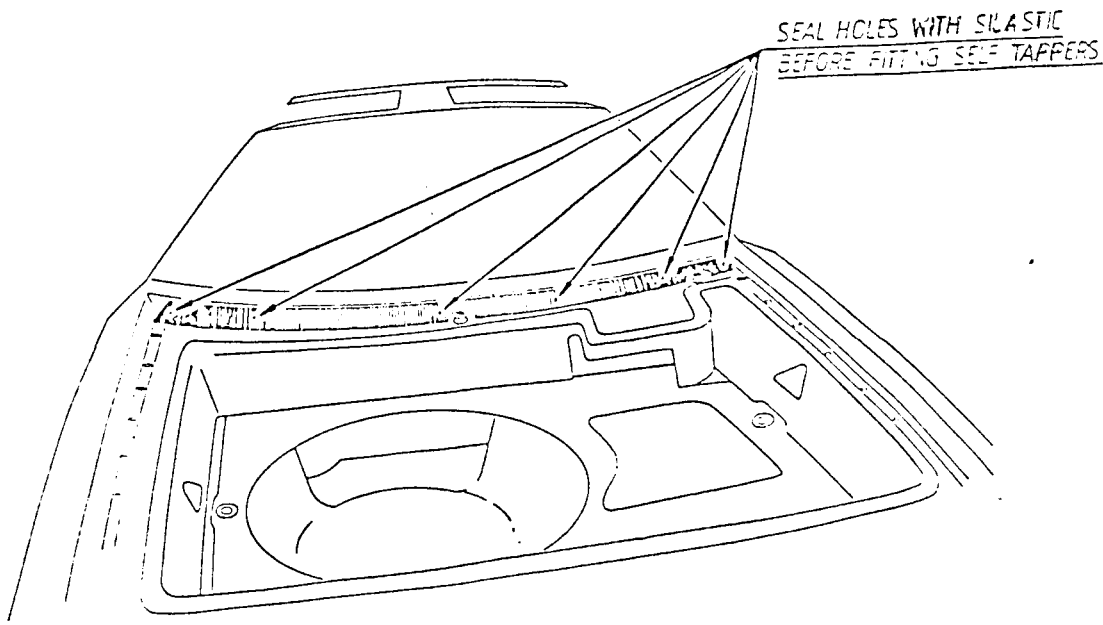

SEAL HOLES WITH SILASTIC BEFORE FITTING SELF TAPPERS

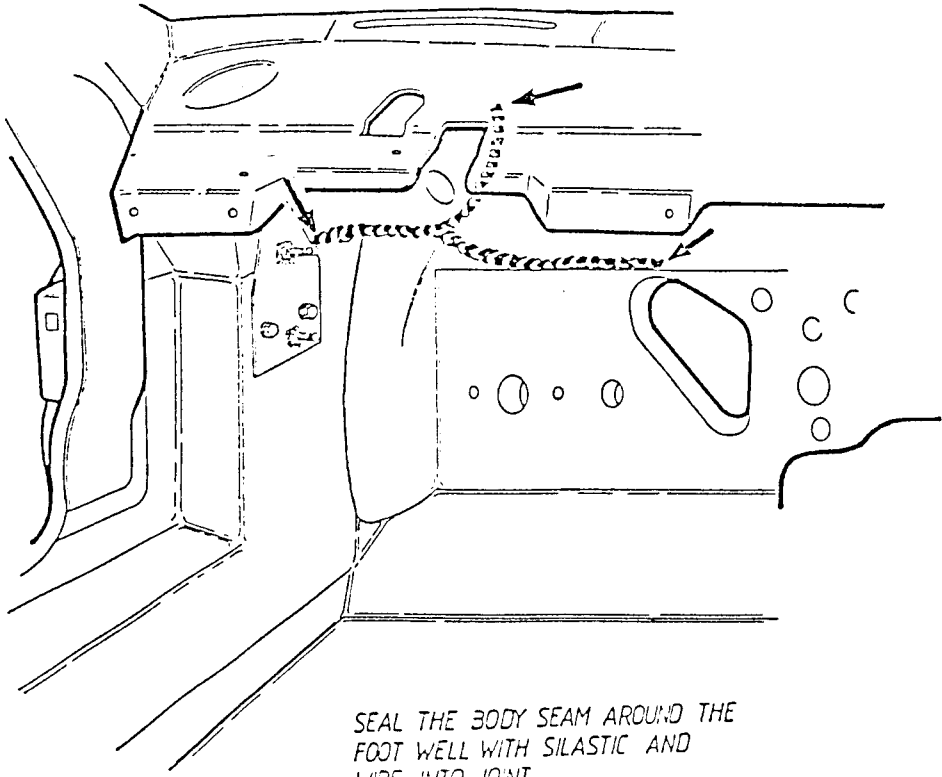

SEAL THE BODY SEAM AROUND THE
FOOT WELL WITH SILASTIC AND
WIPE INTO JOINT

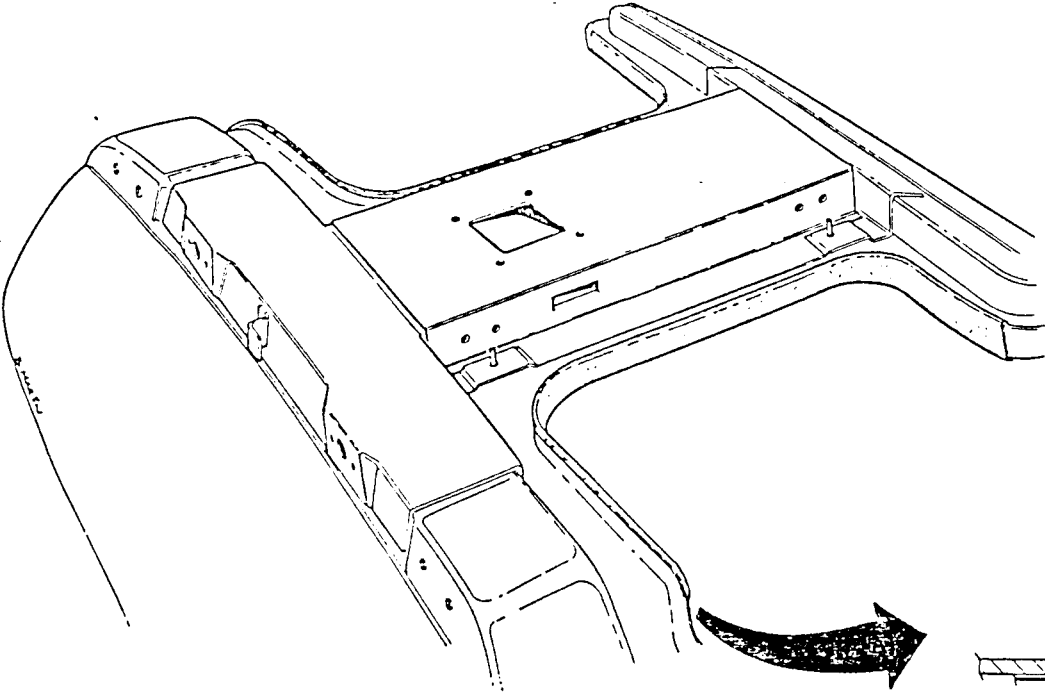

FOLD-OVER:
0-4mm

TYPICAL SECTION
THRU FLANGE

HEADLINING TRIM MATERIAL TO BE
CUT BACK AS FAR AS POSSIBLE