



Eco Water Solutions
www.gorillapumpstations.co.nz
021 745 335



GORILLA PUMP STATIONS
Further and Faster

115L 'Little Silverback' Sewer and Grey Water Pump Station

Installation Instructions

Thank you for purchasing a Gorilla Pump Stations tank and pump unit. These units are designed for RVs, baches, and basement level bathrooms built below the sewer line.

Unpacking

Remove the lid of the tank as the pump is packed within a carton inside the plastic tank.

Remove all packaging. When unpacking please check for possible damage caused in transit.

General dimensions

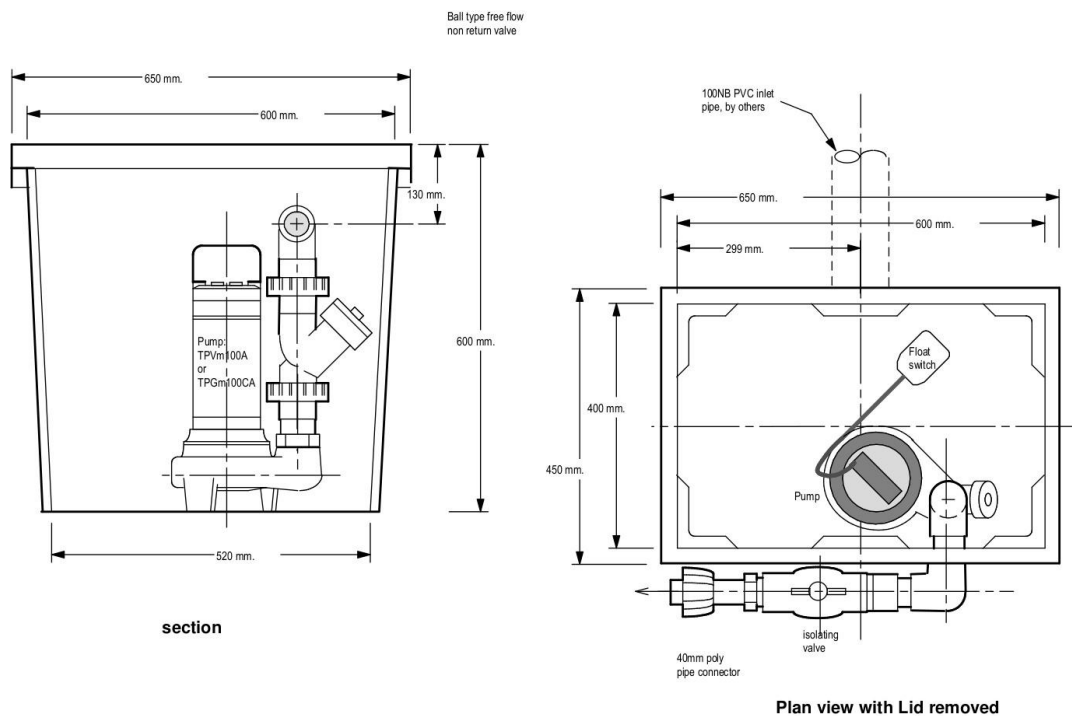

115L Tank Pictured Above.

Outlet connection

The outlet is a 40mm BSP-female screwed socket complete with pipetail for LD alkathene pipe, normally located on right hand side when facing the inlet connection. The elbow is to be in the direction to suit your pipe, glue is supplied for this purpose.

Inlet Connection

Inlet connection is a 110mm ID pipe seal supplied and fitted. A 100mm to 80mm level invert reducer is provided for 80mm pipe.

Assembly

Please refer to the sectional drawings shown below so that you can see how the unit appears.

Do not use the power cable to lift the pump.

Connect the outlet ball valve to the outlet pipe. Use plumbing thread tape to seal

Ensure that the pump is centred in the tank, and that the float switch is free to move up and down without obstruction.

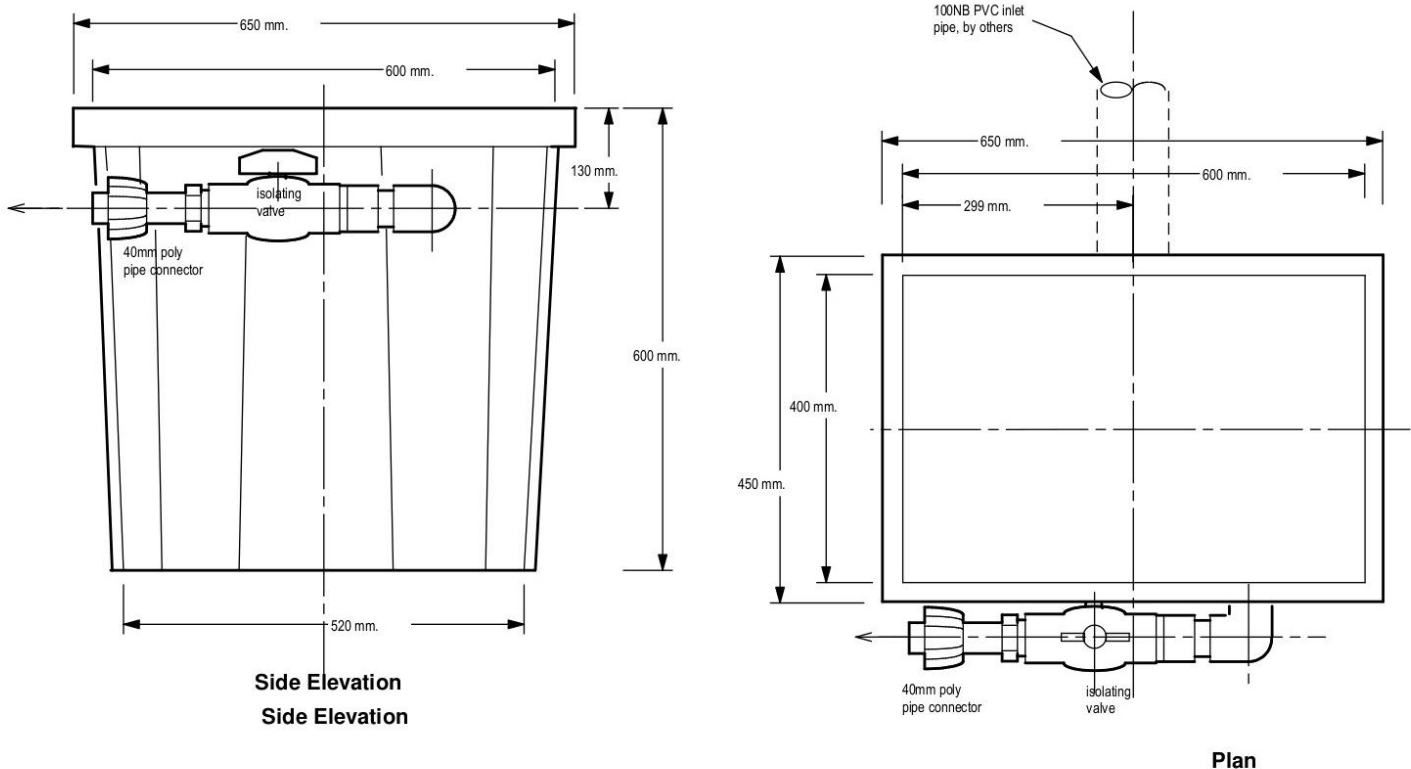

115L Tank Side View and Top View (With Lid)

Read the pump instruction manual supplied with the pump.

The tank lid is constructed from a polyester resin concrete mixture. It is very strong and is able to be walked on if the tank is properly installed in the ground.

The tank and lid is **NOT** designed to take the weight of vehicular traffic, so do not install in driveways or vehicle parking places.

The lid sits into a groove in the top of the tank, which has a rubber sealing foam strip. Place lid securely onto the tank to ensure an even fit.

When digging a hole to install the tank in ground, we recommend a minimum of 75mm of wet concrete be placed in the bottom of the hole and the tank nestled into that level, in order to anchor it in place. The area concreted should be the same as the lid size. Only use soft fill (e.g. sand) around the tank.

If the tank is located in a position that will mean that it will be regularly walked on, we recommend surrounding the top of the tank with concrete as well.

If the tank is to be surface mounted, ensure that it is placed level on a concrete pad or paver.

Outlet

The outlet is supplied UNGLUED to allow for straight or right-angle installation (see below). Glue is supplied with the unit. Ensure pipe has even coating of glue when installing.



Right-Angled Outlet



Straight Outlet

Power Exit Connector

The power outlet unit comes with a 50mm connector to act as a conduit for the pump power cable, as any cable installed in-ground requires installation in a conduit. A 50mm conduit (or similar) pipe will pass a 3-pin plug, and this enables installation without cutting the power cable, and so this eliminates the need for an electrician. **NEVER CUT OFF THE PLUG!**

A 50mm white plug seal is provided to seal cable into outlet connection.

Tip: *if you ever withdraw the pump from the tank and need to remove the cable, tie a piece of string to the plug so that you can pull it back through the electrical conduit later.*

When installing, draw as much cable out through the electrical conduit as possible, rather than let it coil up inside the tank.

>> *Never lift the pump by the cable, as that will damage the pump.
Always lift using the handle on top of the pump.*

Vent Snorkel

A vent snorkel is fitted to the lid of the unit, complete with inbuilt stainless gauze to prevent insects from getting into the tank. Make sure the vent is free from dirty build up.

If the tank is to be buried below ground level, contact us for a vent extension.



Correct Location of Pump In Chamber. Note the room around the float to allow for unobstructed operation.

Pump Specs

VORT Vortex Pump

200L/m	@	1m
150L/m	@	4m
100L/m	@	5.8m
50L/m	@	6.5m

Rated Power	250w
Maximum Particle Size	27mm (NO sand, stones or gravel)
Cable Length	5 Metres

Read the pump instruction manual supplied with the pump.

Reducing conduit size will invalidate warranty.

Use Plumbquick connector between plug outlet and conduit.

An RCD (residual current device) must be used with this product

Maintenance

- Check every two months for build-up of solids or any other matter in pump chambers.
- Periodically wash down the inner walls of the chamber with a high-pressure hose to activate pump and thus flush out the chamber.
- Check that the vent pipe is also clean and free of any obstruction.

NEVER introduce any of the below into a pump or pump chamber....

- Metals, plastics and glass
- Sand (including kitty litter), stones and gravel
- Flammable materials- including petrol, diesel and strong chemicals
- Oils- including lubricating oil, cooking oil, grease and paint
- Tobacco products
- Sanitary products, wet wipes and disposable nappies
- Clothing- including socks and rags
- Dental floss, toothbrushes, cotton balls and band- aids
- Seafood shells
- Pens, pencils and needles