



GORILLA PUMP STATIONS

Further and Faster

Ultra Vortex Pump

A versatile vortex pump suitable for sewerage, greywater and stormwater applications.

Features

- Automatic start/stop via float switch
- Manual override
- Automatically-resetting thermal overload
- Double mechanical seals
- Side discharge
- *Two-year warranty*

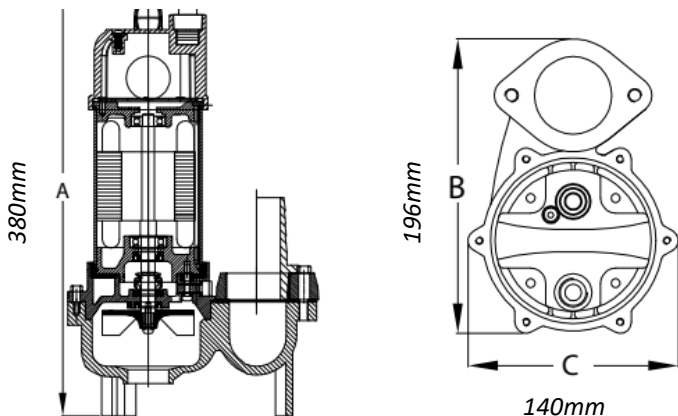

Power	Single-phase	
Motor	230 volt, 250w vortex-type 'sucker pump'.	
Maximum Head	7.5m	
Maximum Water Temperature	40 degrees Celsius	
Outlet Size	40mm	
Weight	9kg	
Maximum Particle Size	27mm soft solids (NO sand, stones or gravel)	
Power Lead Length	Five meters	
Materials	Top Cover/ Impeller: GF Nylon. Motor casing: 304 Stainless Steel Pump Casing: Cast Iron Shaft: 410 Stainless Steel	
Performance Table	Discharge	Head Height
	200L/m	1m
	150L/m	4m
	100L/m	5.8m
	50L/m	6.5m

NOT to be used for drip feeds or lateral lines under any circumstances



GORILLA PUMP STATIONS
Further and Faster

Ultra Vortex Pump

400w Model

A versatile vortex pump suitable for sewerage, greywater and stormwater applications.

Features

- Automatic start/stop via float switch
- Manual override
- Automatically-resetting thermal overload
- Double mechanical seals
- Side discharge
- *Two-year warranty*

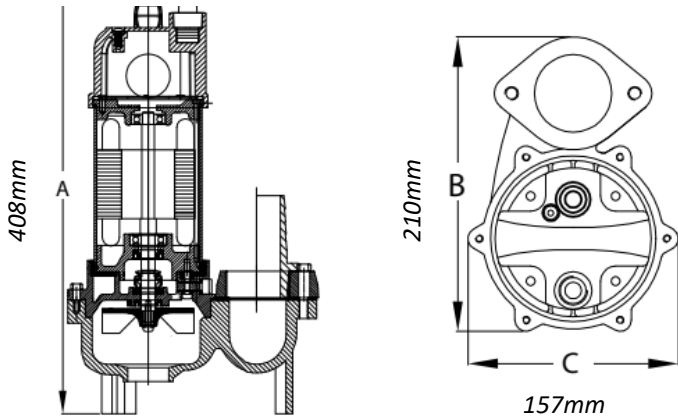

Power	Single-phase	
Motor	230 volt, 400w vortex-type 'sucker pump'.	
Maximum Head	9m	
Maximum Water Temperature	40 degrees Celsius	
Outlet Size	50mm	
Weight	12kg	
Maximum Particle Size	35mm soft solids (NO sand, stones or gravel)	
Power Lead Length	Ten meters	
Materials	Top Cover/ Impeller: GF Nylon. Motor casing: 304 Stainless Steel Pump Casing: Cast Iron Shaft: 410 Stainless Steel	
Performance Table	Discharge	Head Height
	275L/m	1m
	240L/m	3m
	200L/m	5m
	100L/m	8m
	50L/m	9m

NOT to be used for drip feeds or lateral lines under any circumstances

Davies Ultravort Series



DAVIES UV SERIES

Dear Client

Congratulations on your purchase of a quality pump from the Davies range of pumping products.

Like all Davies products, quality and reliability are first and foremost, carefully chosen from manufactures worldwide to carry this proven brand name and deliver years of service.

Please carefully read the owners guide and follow the recommendations to ensure your pump is installed correctly to give you a long and trouble-free service life.



Delivery and Storage

Davies Ultravort UV series pumps are supplied in factory packaging. Please carefully check the pump for damage after shipping to ensure there has been no damage in transit – notify your supplier as soon as possible if you are unsure.

Carefully check the pump model is correct as per your order details and of suitable size and type for your installation. **Do not use power or float leads for lifting or moving the pump.**

Pump Installation

Ensure mains power is disconnected at supply before doing any installation or maintenance. All installations must comply with any applicable local or national codes.

Not suitable for pumping liquids that are hazardous, flammable, explosive or over 40 degrees.

The UV series pumps are designed to pump dirty water with suspended solids not larger than maximum free passage size of the pump – see pump specifications list. Check sump and remove any solids larger than the maximum free passage size prior to installation or they can cause blockages and damage the pump.

Maximum number of pump starts per hour is 30. Design installation and select pump model to keep the number of starts to a minimum. If the pump is going to run for long periods, ensure the motor is submerged above the top cap at all times for adequate cooling.

Ensure system design prevents and protects pump from dry running, dead heading (maximum pressure) or operating below minimum pressure as these conditions may damage the pump.

A lifting rope must be tied securely to the pump handle for installation and lifting for servicing. Do not lift or lower the pump with the electrical cables or float switch as this will damage them.

Pump must be installed in a vertical position on a hard level surface.

Pipe work must not be smaller than the pump discharge and with minimum number of bends or the performance will be affected and there will be an increased risk of blockages.

A ball type non-return valve to prevent backflow and isolator valve with union for servicing must be installed in the discharge pipework.

If the pump is controlled with the integral float switch, ensure this is free of any obstruction that may cause it to get caught and not switch off as run dry will damage the pump and void warranty. Separate run dry protection and control must be provided for pumps without integral float switch.

The pump and pipework must be drained if there is a risk of freezing to prevent damage.

Electrical Installation

All electrical connections must be done by qualified personal in accordance with all national electrical codes. Ensure mains power is disconnected from pump before doing any servicing or maintenance.

Do not use power or float leads for lifting or moving the pump.

Never operate the pump with wet hands or while in contact with water.

DAVIES UV SERIES

Before connecting the pump to the mains power supply, check the Voltage, Amps and frequency corresponds with the motor nameplate rating. Single phase pumps under 10Amps can be connected directly to an electrical outlet, all other models must be connected to a switch or suitable control box such as Simplex. Pump must be earthed to a suitable ground connection in accordance with all national codes prior to any other connections.

Ensure all cables and leads are protected from damage, if possible tapped to pipework or inside conduit to prevent snagging. Protect all connections and plugs from water. Single phase pumps have auto re-set internal thermal overload protection and a capacitor. Caution: The pump will stop from overload tripping but will automatically restart once the motor has cooled sufficiently for overload to reset.

Three Phase pumps must be installed with overload protection supplied by the user and set around 5-10% above full load Amp rating. Lightning, surge and overcurrent protection must be provided by the user. Running pumps off extension cords is not recommended. Impeller rotation must be clockwise when viewed from the top on three phase pumps. This can be reversed by swapping any two of the supply wires. Running backwards can damage the pump and void warranty.

Single phase power supply is 230v +10%, 50Hz.

Three phase power supply is 415v +10%, 50Hz.

Maintenance

Maintenance must only be done by qualified and authorised people. Ensure mains power is disconnected from pump before doing any servicing or maintenance. Pump may be hot after use, allow to cool down before handling.

The UV series pumps require regular visual inspection to check for any leaks in the system, control obstructions, vibrations or noises. If anything is detected this must be recorded and remedied as soon as possible.

The motors and bearings are sealed and no lubrication is required. The shaft lip seal and mechanical seal oil bath should be inspected for wear annually in light duty or quarterly in heavy duty applications. For replacement parts please contact your supplier. Failure to monitor and maintain seal condition or damage to motor caused by seal failure may not be covered by the warranty.

Single phase motors have a run capacitor which may cause overload tripping or unusual noises if this is falling, replace as required. If pump or pipework is getting jammed or blocked regularly, the sump may require cleaning or change system to reduce the amount and size of solids entering.

System Troubleshooting

This is intended as a guide only. For further maintenance of the pump, please contact your supplier.

Cause	Check	Action
Pump won't start	<ol style="list-style-type: none"> 1. Power supply fault. 2. Lead or float damaged. 3. Float switch jammed down. 4. Capacitor blown. 5. Pump blocked or jammed. 	<ol style="list-style-type: none"> 1. Check voltage at supply. 2. Replace damaged parts. 3. Check float for free movement. 4. Contact your supplier. 5. Disconnect from power and remove base. Clear blockages and ensure impeller can turn freely.
Pump won't stop.	<ol style="list-style-type: none"> 1. Float switch jammed up 	<ol style="list-style-type: none"> 1. Check float for free movement.
Pump trips protection breaker.	<ol style="list-style-type: none"> 1. Fuse or circuit breaker incorrect value. 2. Motor damaged. 	<ol style="list-style-type: none"> 1. Check breaker value is correct and replace. 2. Contact supplier.
Pump has low or no delivery flow/pressure or hums.	<ol style="list-style-type: none"> 1. Power supply fault. 2. Capacitor damaged. 3. Pump or pipes blocked. 4. Low water level. 5. Pump sized incorrectly. 6. Air lock in pump casing. 	<ol style="list-style-type: none"> 1. Check voltage and drop in lead. 2. Contact supplier. 3. Lift pump and clear blockage. Check non-return valve. 4. Check pump is submerged. 5. Check system design. 6. Start and stop pump several times to aid priming.
Pump won't run continuously or tripping thermal overload.	<ol style="list-style-type: none"> 1. Power supply fault 2. Capacitor damaged. 3. Voltage drop at pump. 4. Motor operating for too long 	<ol style="list-style-type: none"> 1. Check voltage. 2. Contact supplier. 3. Check cable size and length. 4. Check system design.
Pump is cycling	<ol style="list-style-type: none"> 1. Float switch differential too close. 	<ol style="list-style-type: none"> 1. Allow more movement.

Warranty Policy for Davies Pumps

Your Davies Pump, when used for its designed purpose should give you years of trouble free service. Please take the time to read and understand the operator's manual for this pump before installing and running your pump. Failure to install and operate as per the operation instructions will render warranty on this unit void.

Davies Pumps are warranted to be free of material and manufacturing defects at the time of purchase.

Warranty Period: 2 Years from date of purchase.

This warranty is limited to the cost of the product and does not cover travel charges, removal and re-installation charges, consumables, Electrician or Plumbers charges or any other third party costs unless authorized by Argon Distributors prior to being carried out.

Argon distributors will repair or replace for the consumer any portion of the failed item which has proved to be defective within the warranty period. Replacement product or parts may include refurbished parts or components.

The warranty does not cover Damage or malfunction resulting from:

- A. Misuse, accident, fire, water, lightning, negligence, abuse, product modifications.
- B. Repairs or attempted repairs by unauthorized persons
- C. Damages to product caused by transit
- D. Removal or installation of the product
- E. Normal wear and tear.
- F. Water and Insect ingression
- G. Exposure to corrosive conditions
- H. Dry run
- I. Foreign objects in the liquid being pumped
- J. Electrical power fluctuations
- K. Freight

Argon Distributors liability is limited to the cost of the product and shall not be liable for:

- A. Damage to other property caused by defects in the product.
- B. Loss of use of the product.
- C. Loss of time, loss of profits, loss of business opportunity, loss of goodwill
- D. Any other damages-incidental, consequential or otherwise.
- E. Claims under this warranty must give evidence of the Date of purchase, Invoice Copy, Model, Serial Number, photos and information of the installation as soon as the failure has occurred. Owner's detail must be noted.

If any of the above is unclear please contact your supplier or warranty manager at ARGON DISTRIBUTORS.

Pump Service Records

Declaration of Conformity

For the safety evaluation of the compliance with this Directive 2014/35/EU the following standards were applied:

IEC 60335-2-41:2002/A2:2009 & IEC60335-1:2010

EN 60335-2-41:2003/A2:2010 & EN 60335-1:2012

The above product is in conformity with the Low Voltage Directive 2014/35/EU in order to comply with the requirement in the EUROPEAN COUNCIL DIRECTIVE 2014/35/EU relating to electrical equipment designed for use within certain voltage limits and the Amendment Directive of 2014/35/EU.

Proven solutions through experience

ARGON
DISTRIBUTORS LTD



argondistributors.co.nz