

DCX-1500A High-Pressure Pump

High-pressure clean-water drainage pump for septic tank greywater systems.

Features

- Double mechanical seals.
- Continuous-rated motor with incorporated thermal protector.
- Automatic start/stop via float switch
- Designed for high-pressure lateral and drip feed lines only.
- *One-year warranty*

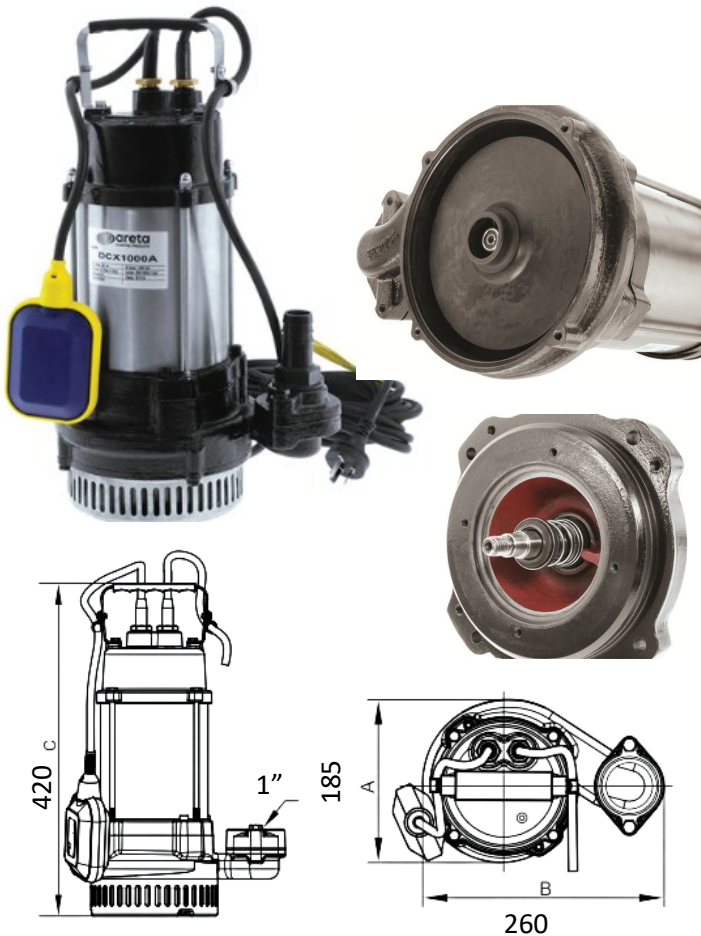

Power	Single-phase	
Motor	1.1kW, 1.5HP, 230v.	
Maximum Head	33m	
Maximum Water Temperature	40 degrees Celsius	
Outlet Size	25mm	
Maximum Particle Size	5mm (NO sand, stones or gravel)	
Power Lead Length	10 meters	
Materials	<p><i>Main Body: Cast Iron</i></p> <p><i>Motor Housing: 304-Stainless Steel</i></p> <p><i>Mechanical Seals (in oil bath): Silicon carbide (pump side), Carbon/Silicon Carbide (Motor Side)</i></p> <p><i>Impeller with glass fibre reinforcing</i></p>	
Performance Table	Discharge	Head Height
	150L/m	15m
	120L/m	20m
	90L/m	25m
	50L/m	30m
	20L/m	33m