



**Eco Water Solutions**

PO Box 18 Foxton Beach

021 745 335

www.ecowater.co.nz

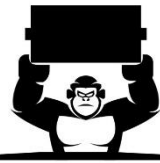

**GORILLA PUMP STATIONS**

Further and Faster

## 320 Litre Sewage Tank Pump Unit

### Installation Instructions

Thank you for purchasing an Eco Water Solutions 320L sewage tank and pump unit. These units are designed for tiny houses, baches, and basement level bathrooms built below the sewer line.

#### Unpacking

Before purchasing your pump station, please ensure that it meets regulatory requirements for its application.

The tank is made of polypropylene and is usually transported with the top half wrapped with cling-film. Inside wrapped in bubble-wrap is the discharge isolating valve, and the non-return valve and riser assembly.

The pump is supplied loose packed in a separate carton, and lifting chain is attached to the pump.

Check that the pump is the required unit and inspect for any damage to tank and fittings.

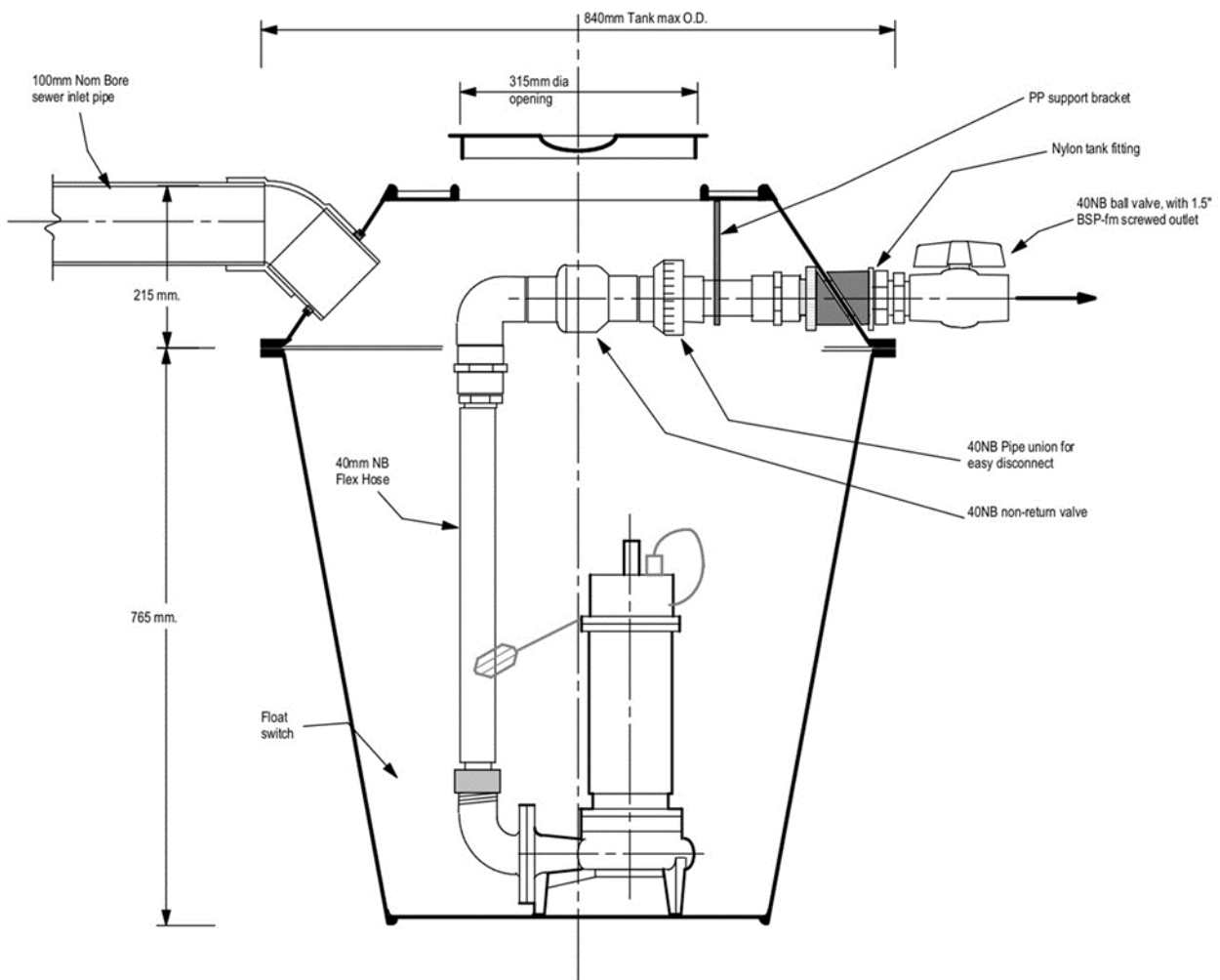

## **General dimensions**

The tank is 840mm diameter at its widest point.

The base is 500mm dia.

Overall height is 980mm.

The manhole on the top is 315mm i.d. (*Lid is not pedestrian-rated*)

A 230mm high/470mm wide manhole extension can be supplied for fully underground installations.

## **Outlet connection**

The outlet is a 40mm BSP-female screwed socket, located directly opposite the inlet connection.

## **Inlet Connection**

The Inlet connection has a 110mm i.d. rubber sealing ring to suit NZ standard 110mm dia PVC sewer pipe.

The pipe will slide inside the rubber ring for a tight fit.

There are two secondary connections supplied loose with the tank:

1. Secondary waste pipe connection,
2. 50mm fitting, for 50mm vent pipe connection
3. 50mm fitting for cable exit. Use 50mm suitable pipe as ducting. These will allow for easy pump removal. **Using a smaller size will invalidate the warranty.**

These connections are supplied loose so that they can be positioned anywhere on the top half of the tank to suit site conditions.

## **Assembly**

Please refer to the sectional drawings within this manual so that you can see how the unit appears when fully assembled.

When fitting the 110mm o.d. sewer pipe into the sealing ring, it is best to apply soapy water to the ring, to ease insertion of the pipe.

Screw the discharge pipe and non-return valve assembly into the pump outlet.

Lower the pump into the tank using the chain, and then Hang the chain on the hook provided.

***Do not use the power cable to lift the pump.***

After placing the pump and pipe in the tank, connect the Pipe union to the outlet pipe.

Connect the isolating ball valve to the outlet pipe outside the tank.

When connecting the pipe union and the valve, check that the sealing O-ring is in place, and is not loose in the bottom of the tank.

Ensure that the pump is centred in the tank, and that the float switch is free to move up and down without obstruction.

**Read the pump instruction manual supplied with the pump.**

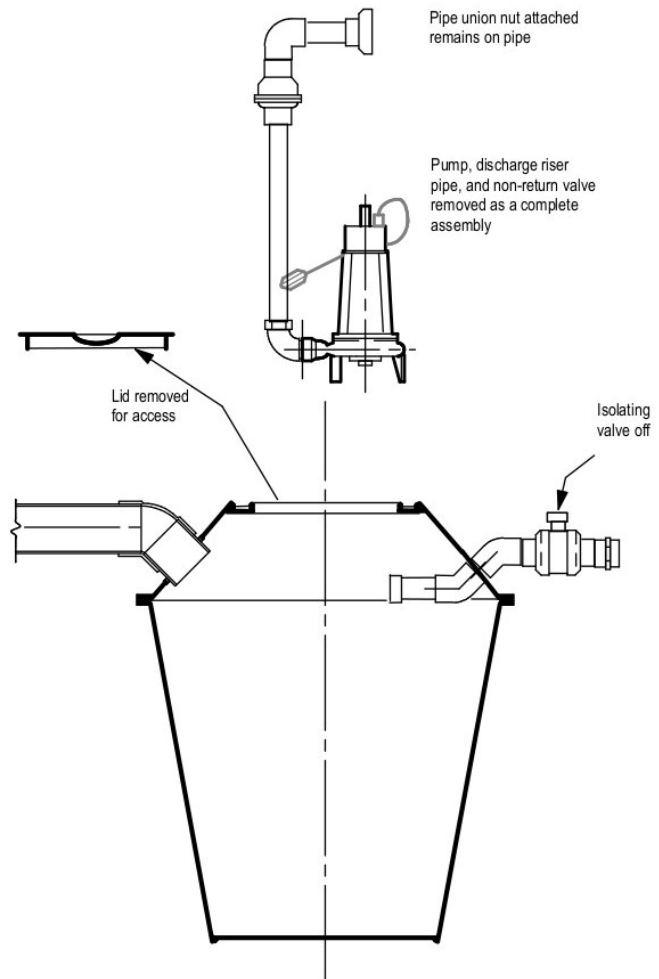

The tank lid is polypropylene, made with reinforcing ribs. It is not designed to be walked on or used as part of a path. If you do want to install it in a pathway, then bury it fully in the ground and install a concrete path above containing a cast iron frame and manhole cover.

The tank and lid are not designed to take the weight of vehicular traffic, so do not install in driveways or vehicle parking places.

The lid sits into the opening in the top of the tank and is retained with two Tek screws.

**When digging a hole in the ground to install the tank in ground, we recommend a minimum of 100mm of wet concrete, wider than the exterior diameter of the tank, be placed in the bottom of the hole and the tank nestled into that, in order to anchor it in place.**

***If you wish to anchor the tank using the outside flange, contact us for recommended clips. Four-point deadweight anchoring from flange if this is required.***

***Deadweight anchoring at the time of installing concrete base is recommended for high water tables or soft soil substrates. (Strapping should be attached from dead weight over the top of the tank)***

## **Venting Installation.**

Supplied loose with the tank is a 50mm wastewater pipe socket set. This unscrews into two halves. A 60mm diameter hole saw is required for installation.

The purpose of this fitting is to provide connection for a 50mm vent pipe. This is because the tank needs venting as levels can change suddenly within the tank, such as when a toilet is flushed or a sink drained, and levels can also change rapidly when the pump switches on.

A 50mm white plug seal is provided to seal cable into outlet connection.

## **Cable Installation**

*An RCD (residual current device) must be used with this product!*

A 50mm pipe is required also to act as a conduit for the pump power cable, as any cable installed in-ground requires installation in a conduit. A 50mm electrical (or similar, depending on Local Authority requirements) pipe will pass a 3-pin plug, and this enables installation without cutting the power cable, and so this eliminates the need for an electrician.

A 50mm white plug seal is provided to seal cable into outlet connection.

The power connection fitting is supplied loose so that you can install it in the best position to suit site. To install use a holesaw to cut a hole 60mm diameter, then fit the male part within the tank inserting the threaded portion through the hole, and then screw the female part on to it outside the tank and tighten. Use a plumbquick or similar to connect power ducting to tank connection. There is a white rubber seal bung to place cable into to seal the power outlet.

**Tip:** *if you ever withdraw the pump from the tank and need to remove the cable, tie a piece of string to the plug so that you can pull it back through the vent pipe later.*

When installing, draw as much cable out through the ducting pipe as possible, rather than let it coil up inside the tank.

**>>** *Never lift the pump by the cable, as that will damage the pump.  
Always lift using the handle and/or chain on top of the pump.*

## Maintenance

- Tank requires regular checks to ensure no fat or oils have formed at the top of the chamber. **If not regularly checked the float may malfunction which will invalidate warranty.**
- Tank requires checking for solids build-up. Installation is required by a registered plumber.
- Check regularly for build up of solids or any other matter in pump chambers.
- Periodically wash down the inner walls of the chamber with a high pressure hose to activate pump and thus flush out the chamber.
- Check that the vent pipe is also clean and free of any obstruction.

*When installing manhole riser use stainless steel and silicone joints.*

Please check on our website ([www.gorillapumpstations.co.nz](http://www.gorillapumpstations.co.nz)) for warranty conditions.

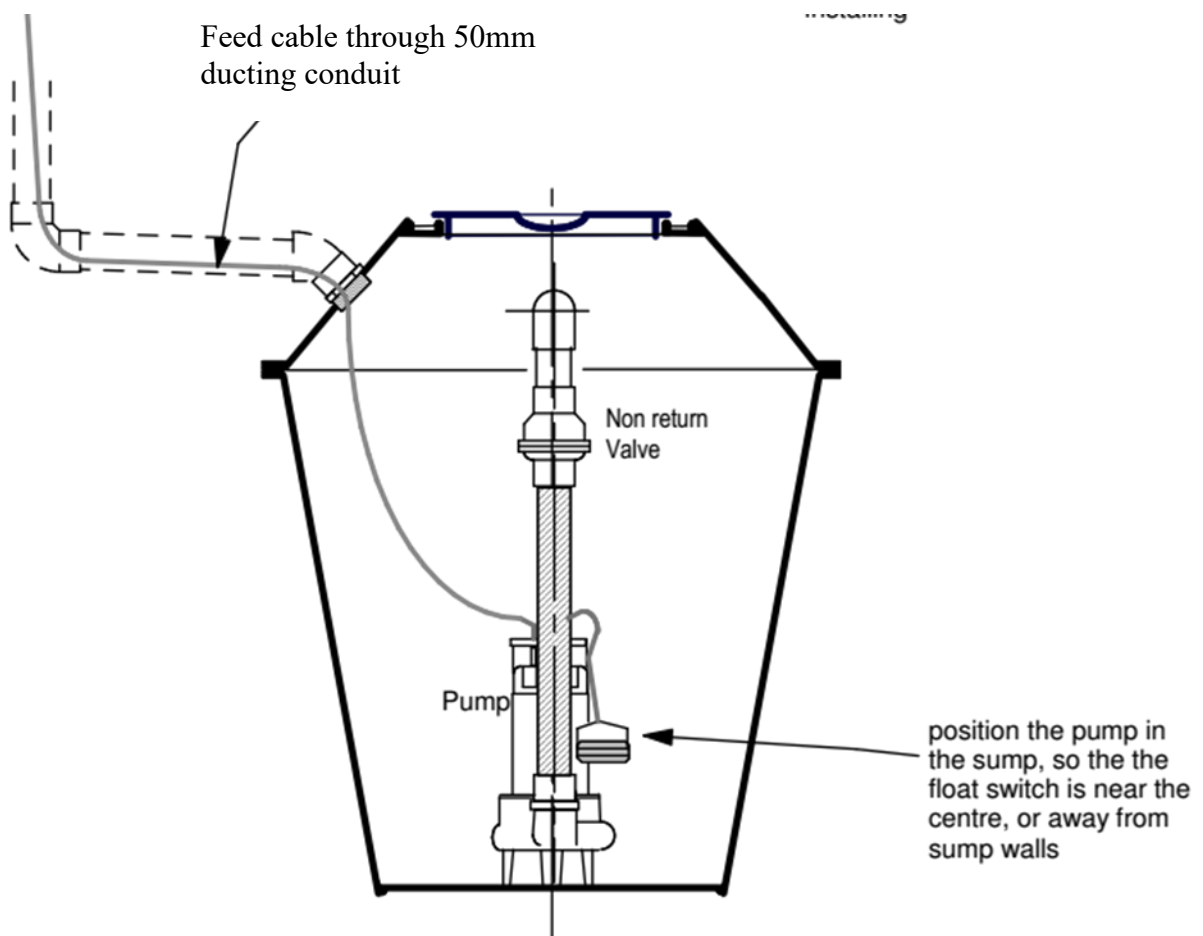

**Read the pump instruction manual supplied with the pump.**

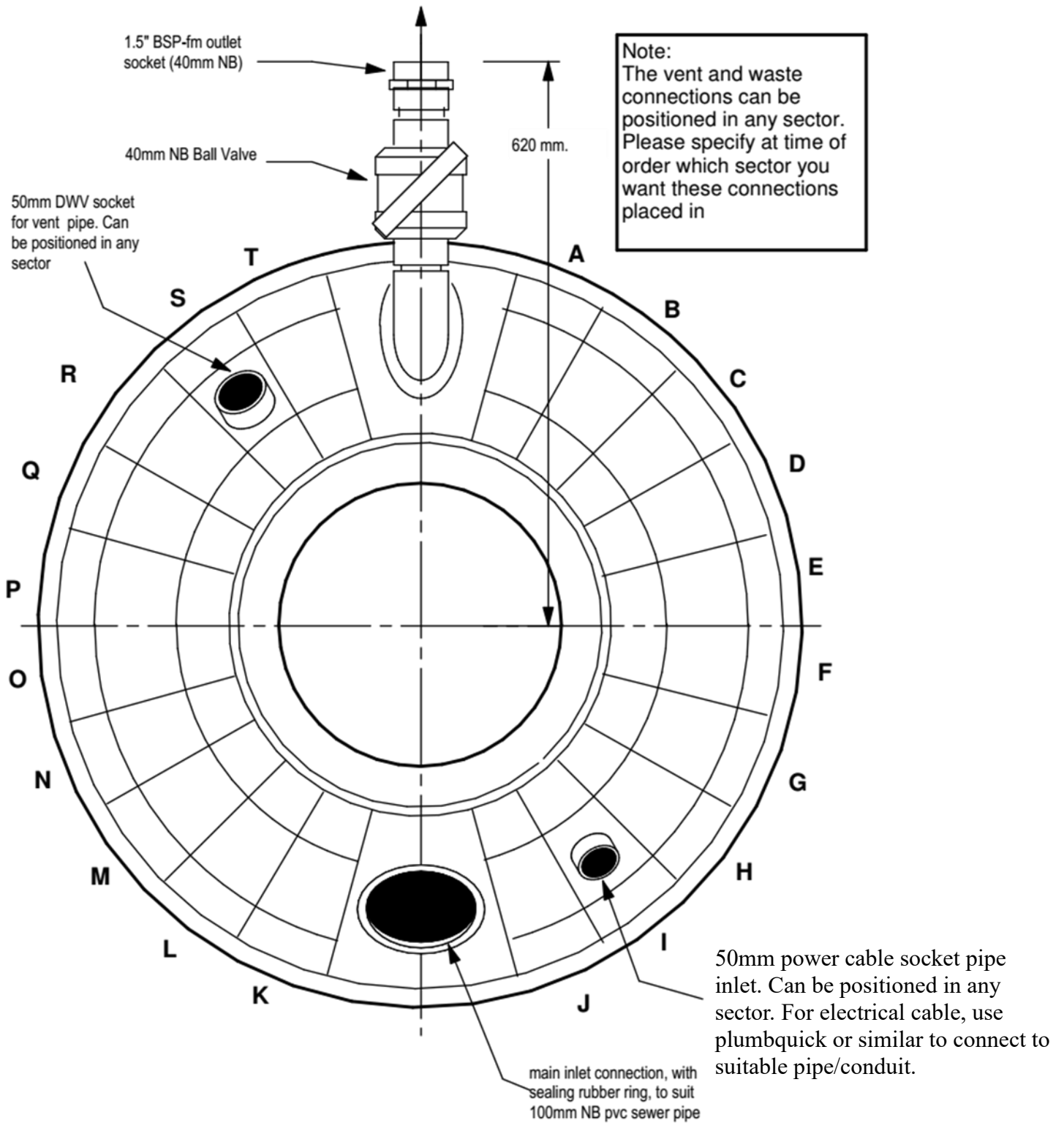

**Pump Specs**

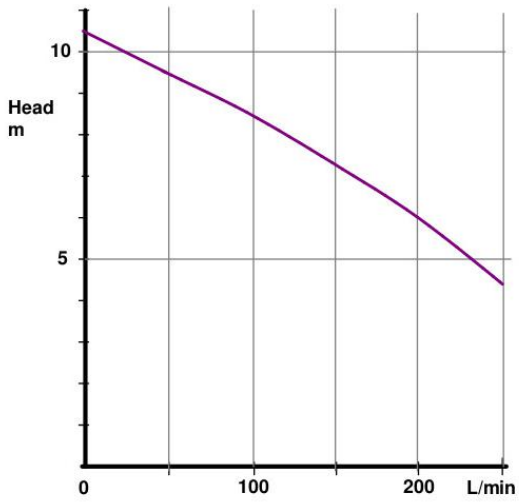

**VH100**

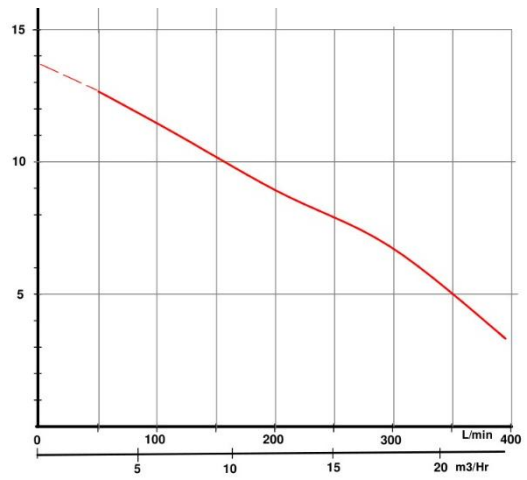

**TPG100 (N)**

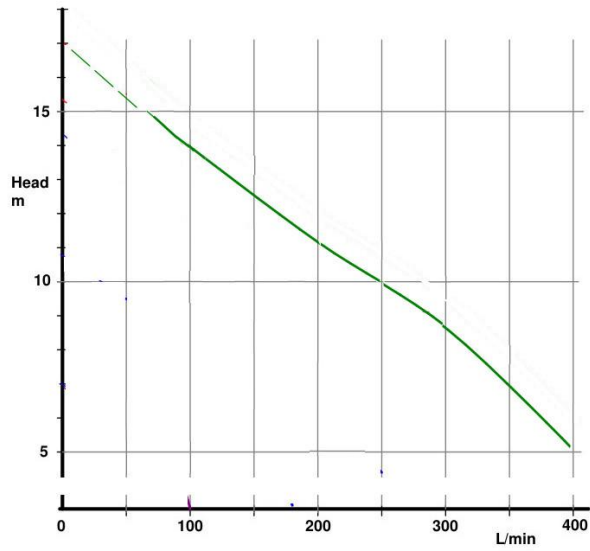

**C-50Z21.5SF**