

Spotted Spring Spectacular

Reining Class #1, 2, 3

Show Date: May 29-31, 2026

REINING PATTERN 2

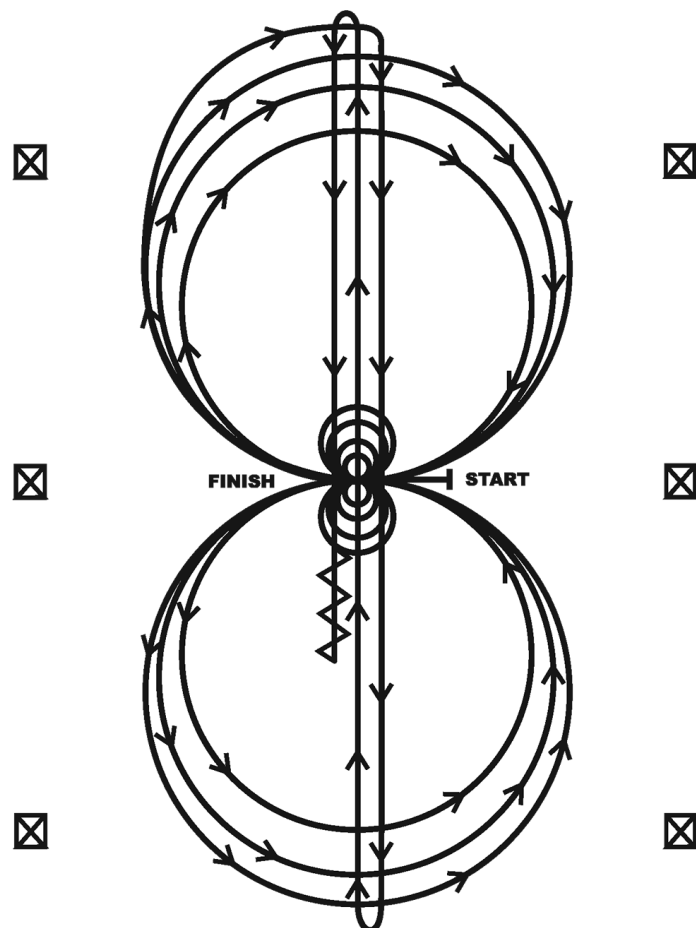

Horses may walk or jog to the center of arena. Horses must walk or stop prior to starting pattern. Beginning at the center of the arena facing the left wall or fence.

1. Beginning on the right lead, complete three circles to the right: the first circle small and slow; the next two circles large and fast. Change leads at the center of the arena.
2. Complete three circles to the left: the first circle small and slow; the next two circles large and fast. Change leads at the center of the arena.
3. Continue around previous circle to the right. At the top of the circle, run down the middle to the far end of the arena past the end marker and do a right rollback—no hesitation.
4. Run up the middle to the opposite end of the arena past the end marker and do a left rollback—no hesitation.
5. Run past the center marker and do a sliding stop. Back up to the center of the arena or at least ten feet (three meters). Hesitate.
6. Complete four spins to the right. Hesitate.
7. Complete four spins to the left. Hesitate to demonstrate the completion of the pattern.

[R/AQHAP-2]

Pattern Provided by:

Spotted Spring Spectacular

Ranch Reining Class #4, 5, 6, 7

Show Date: May 29-31, 2026

REINING PATTERN I

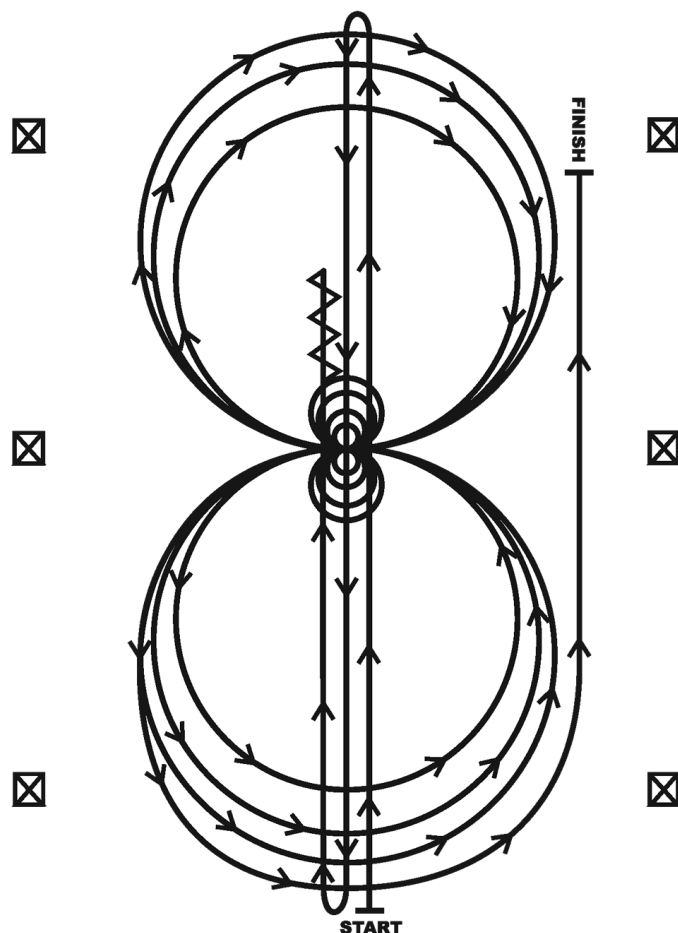

1. Run at speed to the far end of the arena past the endmarker and do a left rollback—no hesitation.
2. Run to the opposite end of the arena past the end marker and do a right rollback—no hesitation.
3. Run past the center marker and do a sliding stop. Back up to center of the arena or at least ten feet (three meters). Hesitate.
4. Complete four spins to the right. Hesitate.
5. Complete four and one-quarter spins to the left so that horse is facing left wall or fence. Hesitate.
6. Beginning on the left lead, complete three circles to the left: the first circle large and fast; the second circle small and slow; the third circle large and fast. Change leads at the center of the arena.
7. Complete three circles to the right: the first circle large and fast; the second circle small and slow; the third circle large and fast. Change leads at the center of the arena.
8. Begin a large circle to the left but do not close this circle. Run straight up the right side of the arena past the center marker and do a sliding stop at least twenty feet (six meters) from wall or fence. Hesitate to demonstrate the completion of the pattern.

[R/AQHAP-1]

Pattern Provided by:

Spotted Spring Spectacular

Western Riding, Class #8, 9, 10

Show Date: May 29-31, 2026

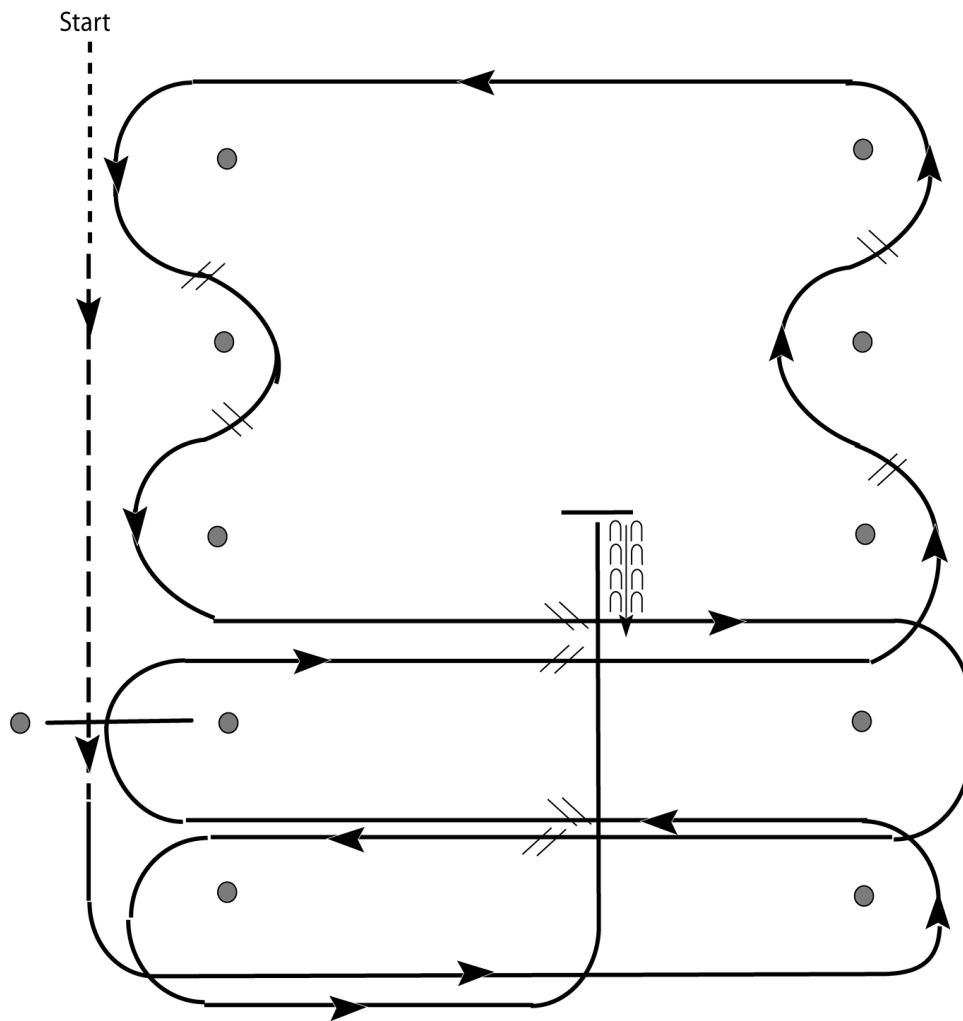

1. Walk, transition to jog, jog over log.
2. Transition to left.
3. First crossing change.
4. Lope over log.
5. Second crossing change.
6. First line change.
7. Second line change.
8. Third line change.
9. Fourth line change.
10. Third crossing change.
11. Fourth crossing change.
12. Lope up the center, stop and back.

[WR/OP-3]

Pattern Provided by:

2026 Spring Show

Ranch Riding

W W W . H O R S E S H O W P A T T E R N S . C O M

W W W . H O R S E S H O W P A T T E R N S . C O M

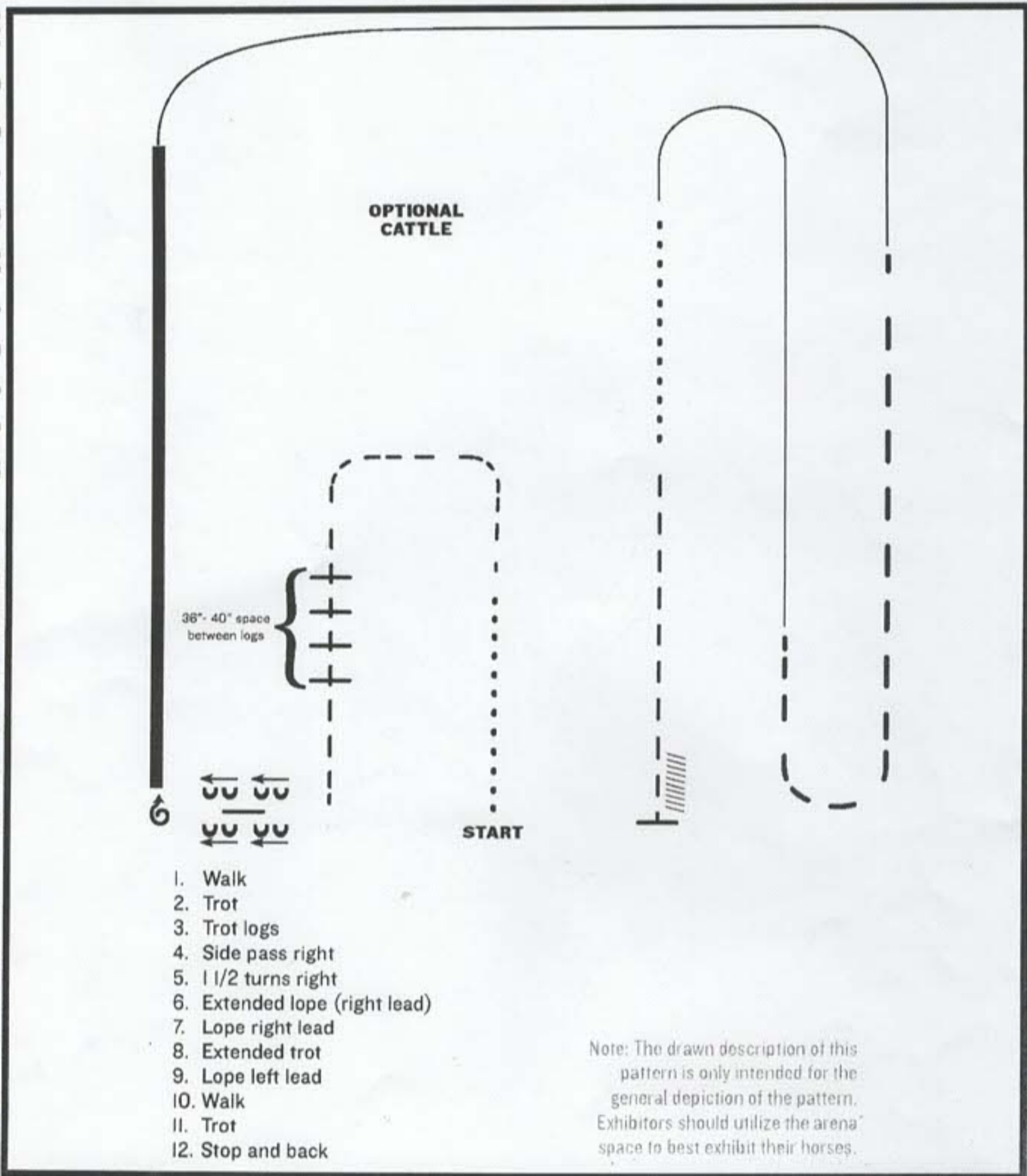

1. Walk
2. Trot
3. Trot logs
4. Side pass right
5. 1 1/2 turns right
6. Extended lope (right lead)
7. Lope right lead
8. Extended trot
9. Lope left lead
10. Walk
11. Trot
12. Stop and back

Note: The drawn description of this pattern is only intended for the general depiction of the pattern. Exhibitors should utilize the arena space to best exhibit their horses.

Spotted Spring Spectacular

Showmanship Class #40

Show Date: May 29-31, 2026

w w w . H o r s e S h o w P a t t e r n s . c o m

w w w . H o r s e S h o w P a t t e r n s . c o m

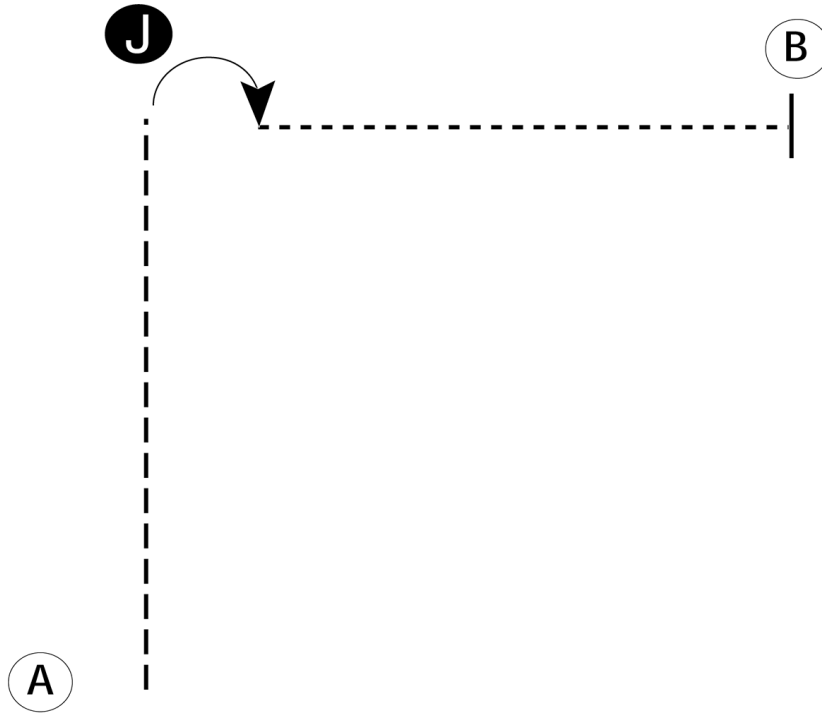

Be ready at A.

1. Trot from A to Judge.
2. Stop and set up for inspection.
3. When dismissed, perform a 90 degree turn.
4. Walk away from judge to B.
5. Stop at B.
6. Follow the instructions of your ring steward.

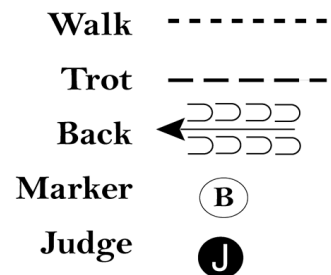

[S/WT-8]

Pattern Provided by:

Spotted Spring Spectacular

Showmanship Class #41, 42, 43, 44

Show Date: May 29-31, 2026

w w w . H o r s e S h o w P a t t e r n s . c o m

w w w . H o r s e S h o w P a t t e r n s . c o m

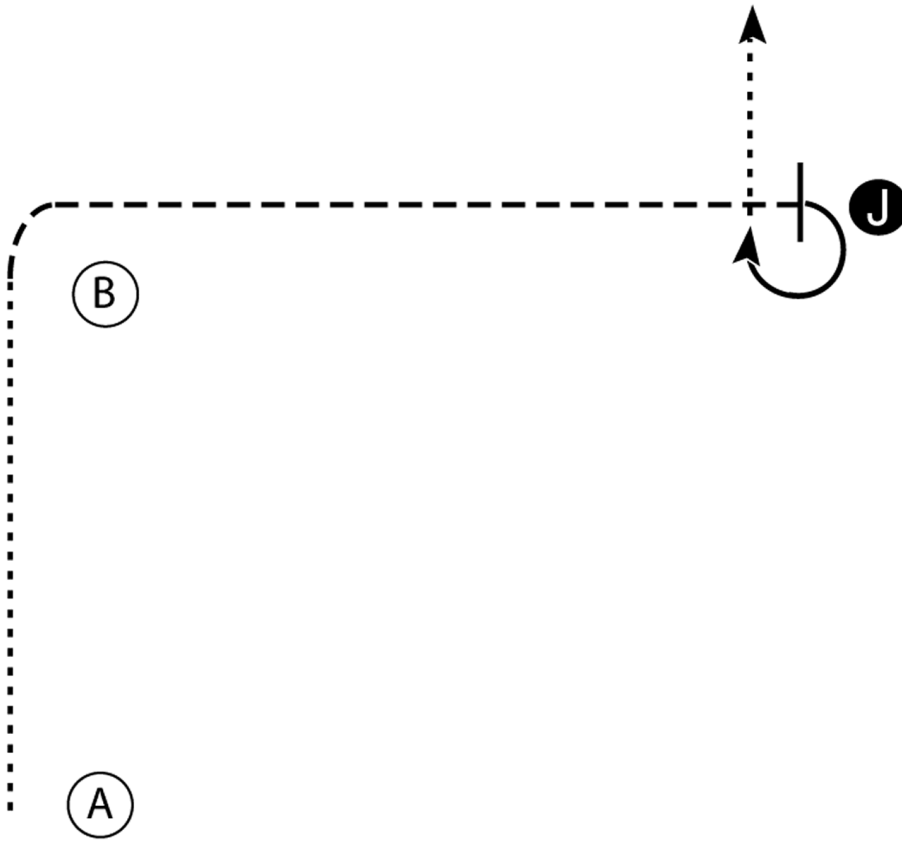



1. Walk from A to B.
2. Trot from B to the Judge.
3. Stop and set up for inspection.
4. When dismissed perform a 270 degree turn and walk straight away from the Judge.

Walk 

Trot 

Back 

Marker 

Judge 

[S/WT-2]

Pattern Provided by:

Spotted Spring Spectacular

Showmanship Class #45-54

Show Date: May 29-31, 2026

w w w . H o r s e S h o w P a t t e r n s . c o m

w w w . H o r s e S h o w P a t t e r n s . c o m

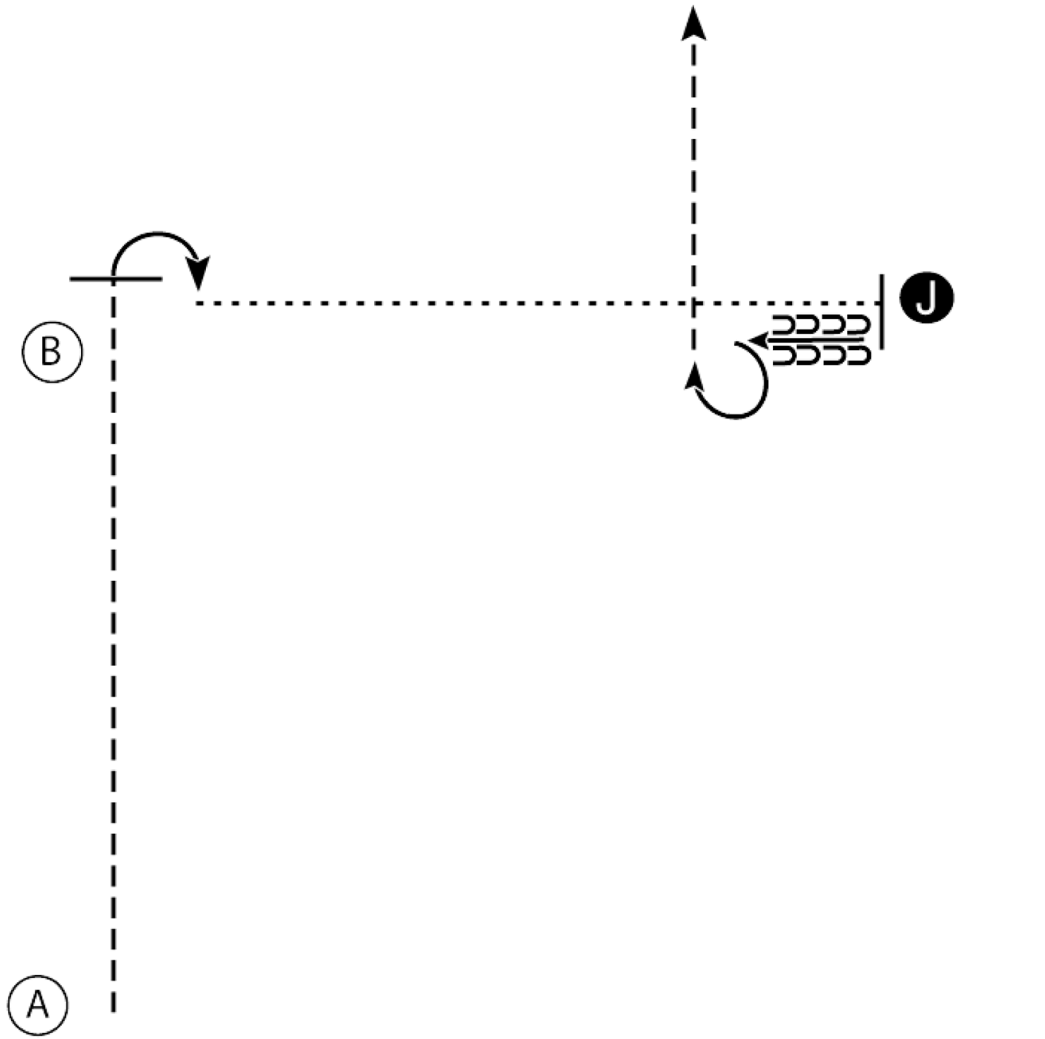

1. Begin at A. Trot from A past B
2. Stop and perform a 90 degree turn
3. Walk to the Judge, stop and set up for inspection
4. When dismissed back one horse length and perform a 270 degree turn
5. Trot to the line-up

Walk
Trot - - - - -
Back ←
Marker (B)
Judge (J)

Pattern Provided by:

[S/WT-3]

Spotted Spring Spectacular

Showmanship Class #55

Show Date: May 29-31, 2026

w w w . H o r s e S h o w P a t t e r n s . c o m

w w w . H o r s e S h o w P a t t e r n s . c o m

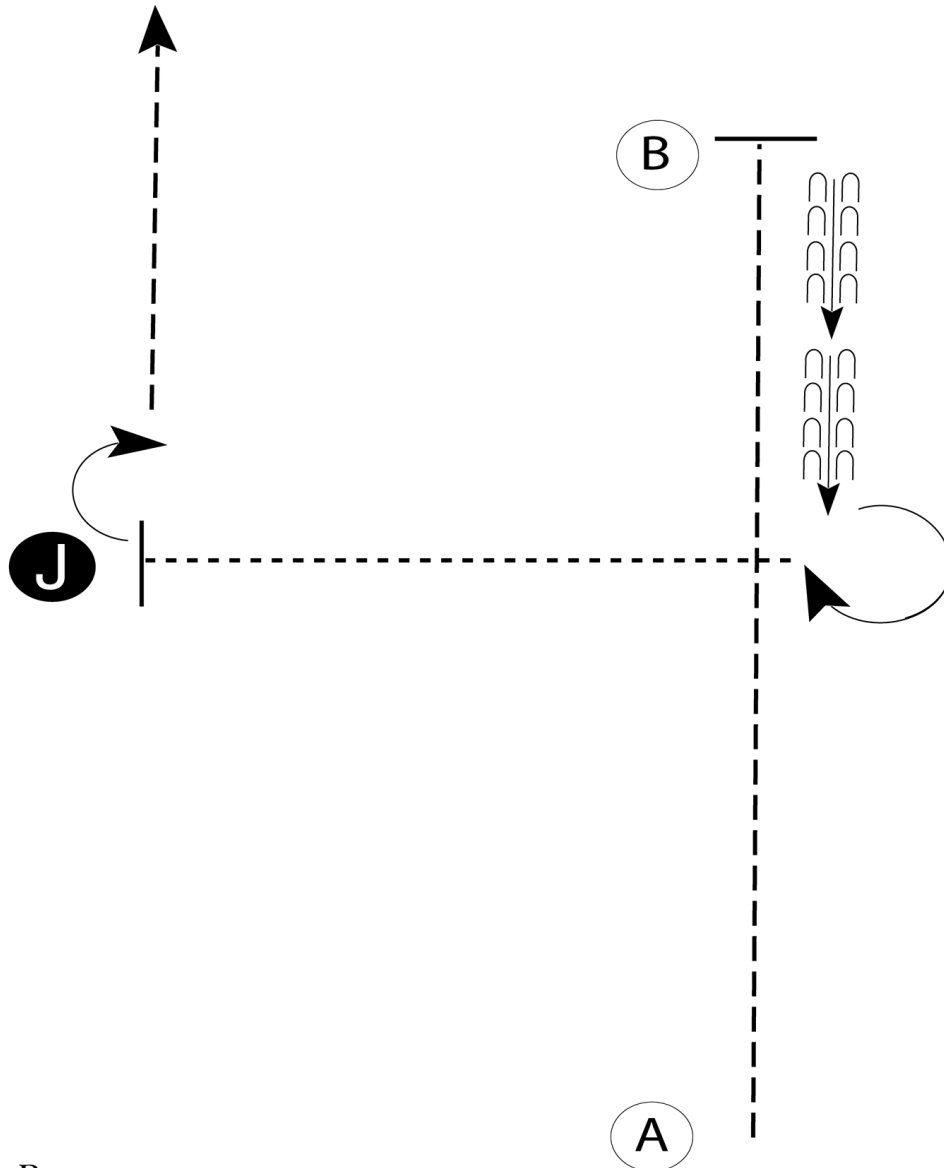

1. Trot A to B.
2. Stop at B.
3. Back halfway to A.
4. Perform a 270 degree turn .
5. Walk to the judge, stop and set up for inspection.
6. When dismissed, perform a 90 degree turn and trot away from judge.

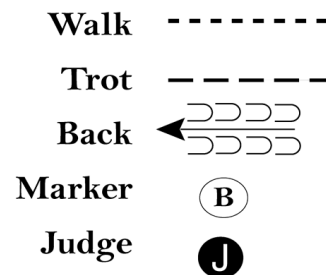

Follow the instructions of your ring steward.

Pattern Provided by:

[SWT-1]

Spotted Spring Spectacular

Western Horsemanship Class 157, 158, 159

Show Date: May 29-31, 2026

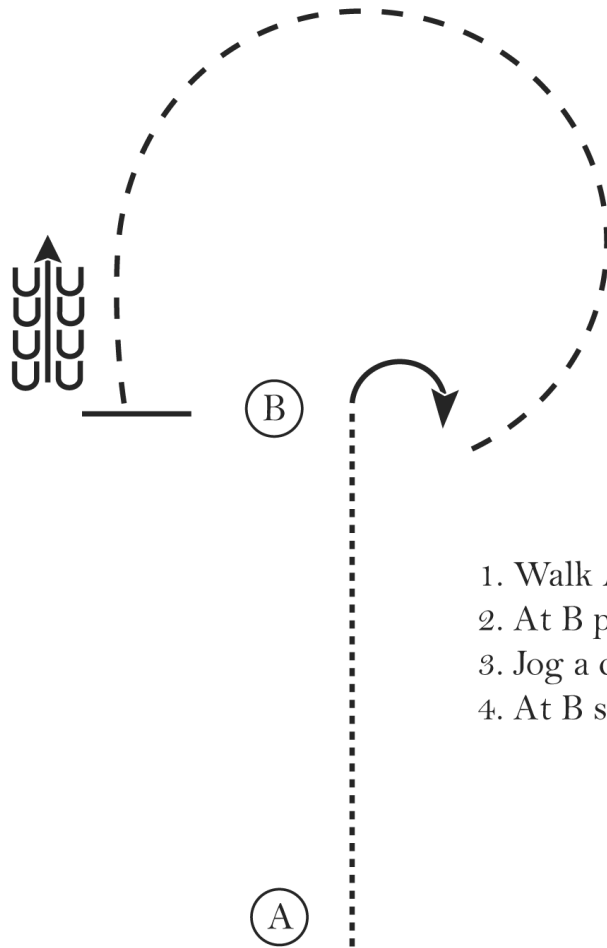

1. Walk A to B
2. At B perform a 90 degree turn to the right
3. Jog a circle around B
4. At B stop and back 4 steps

Walk
Jog	-----
Extended Jog	- - - - -
Lope	—————
Leg Yield	
Lead Change	↘
Back	←←←←← ←←←←←
Marker	(B)
Sidepass	←←←←←

[WH/WT-7]

Pattern Provided by:

Spotted Spring Spectacular

Western Horsemanship Class #160-167

Show Date: May 29-31, 2026

w w w . H o r s e S h o w P a t t e r n s . c o m

w w w . H o r s e S h o w P a t t e r n s . c o m

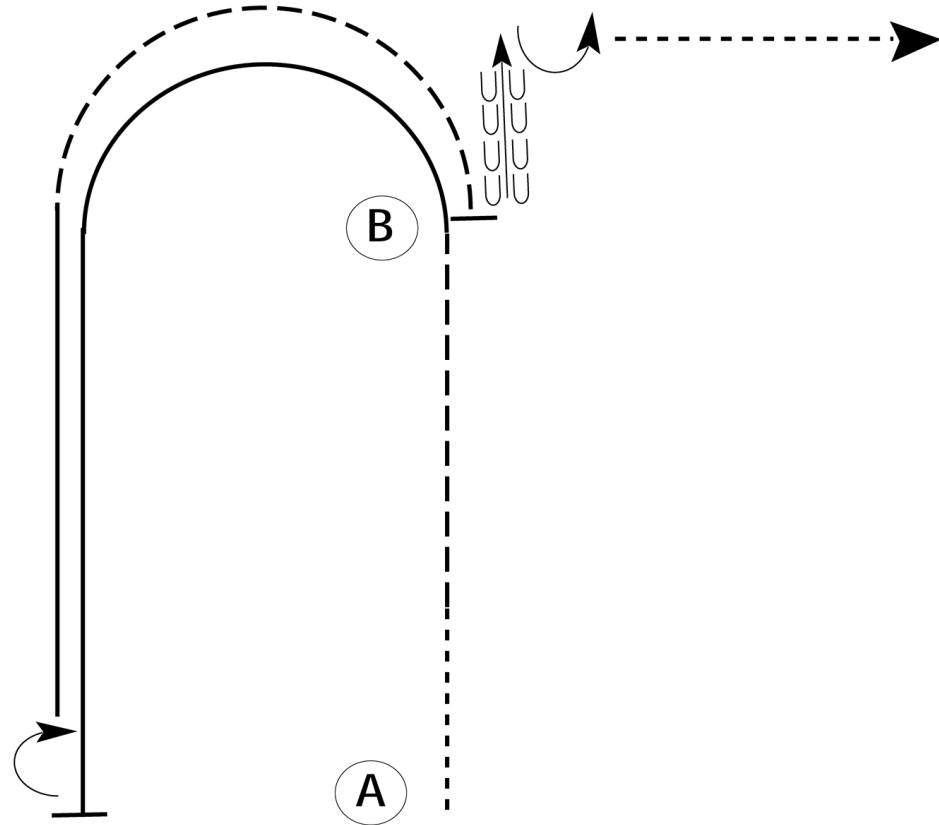

Be ready at A.

1. Walk approximately 2 horse lengths from A.
2. Jog to B.
3. Lope on the left lead in a half circle and then straight until even with A.
4. Stop and perform a 180 degree turn to the right.
5. Lope on the right lead until even with B.
6. Jog to B.
7. Stop at B and back approximately one horse length.
8. Perform a 90 degree turn to the left and walk straight away.

Follow the instructions of your ring steward.

Walk
Jog	-----
Extended Jog	-----
Lope	—————
Lead Change	———/———
Back	←———
Marker	ⓑ

[WH/1-84]

Pattern Provided by:

Spotted Spring Spectacular

Saddle Seat Equitation Class #174, 175

Show Date: May 29-31, 2026

w w w . H o r s e S h o w P a t t e r n s . c o m

w w w . H o r s e S h o w P a t t e r n s . c o m

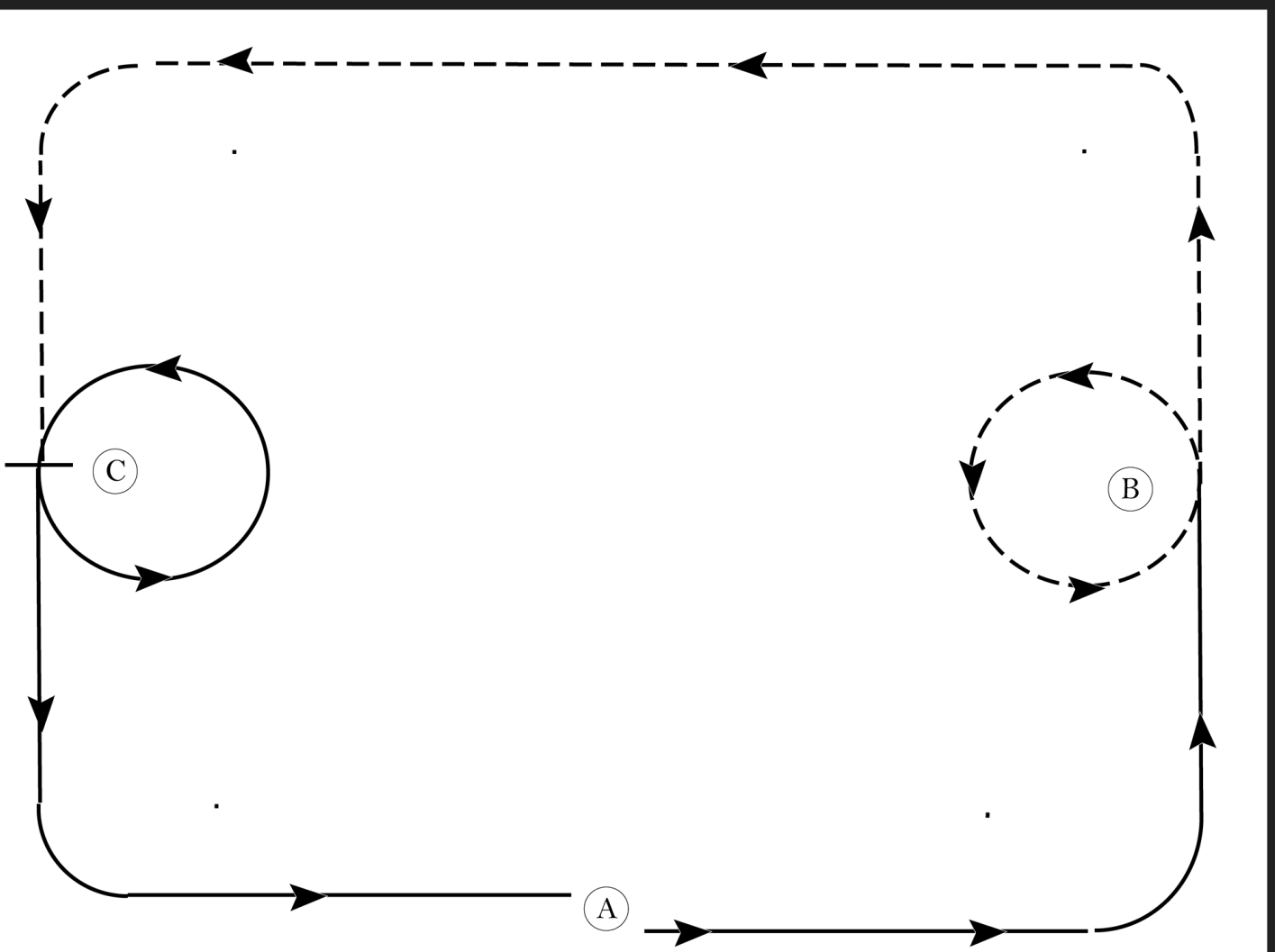

Begin at the mid-point of the in gate end of arena (A).

1. Canter to the right, around the curve and to the mid-point of the straightaway (B).
2. Trot a circle in a counter clockwise direction.
3. Trot on the rail to the mid- point of the opposite straightaway (C). Stop briefly.
4. Canter a circle in a counter clockwise direction.
5. Canter down the straightaway, around the corner and to the mid-point of the straightaway (A).

Walk	-----
Trot	- - - - -
Extended Trot	—————
Canter	—————
Lead Change	———/———
Back	←←←←←
Reference Point	⊙

The workout has been completed - Thank You.

[SSE/4]

Pattern Provided by:

Spotted Spring Spectacular

Hunt Seat Equitation Class 208, 209, 210

Show Date: May 29-31, 2026

w w w . H o r s e S h o w P a t t e r n s . c o m

w w w . H o r s e S h o w P a t t e r n s . c o m

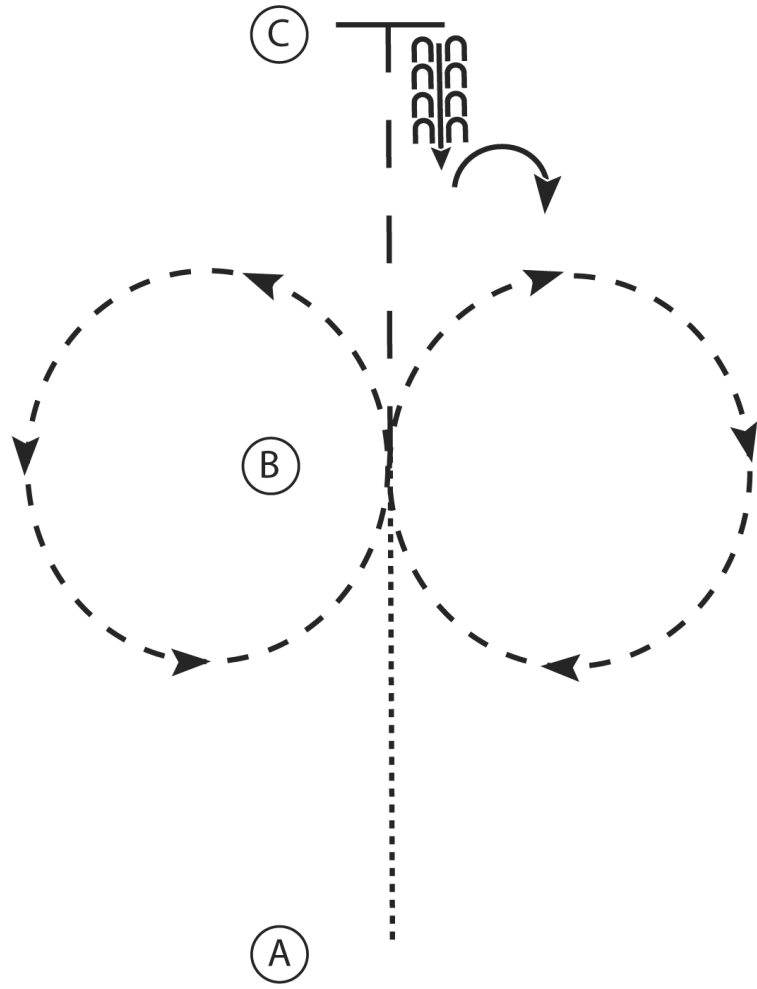

1. Walk A to B
2. Sitting trot circle to the right
3. Posting trot circle to the left
4. At B extend the trot to C
5. Stop at C and back 4 steps
6. Perform a 90 degree turn to the right

Walk
Trot	- - - - -
Extended Trot	- - - - -
Canter	—————
Leg Yield	
Lead Change	— / —
Back	←←←←←
Marker	⊙ B
Sidepass	- - - - - ←

[HSE/WT-1]

Pattern Provided by:

Spotted Spring Spectacular

Hunt Seat Equitation Class #211-216

Show Date: May 29-31, 2026

w w w . H o r s e S h o w P a t t e r n s . c o m

w w w . H o r s e S h o w P a t t e r n s . c o m

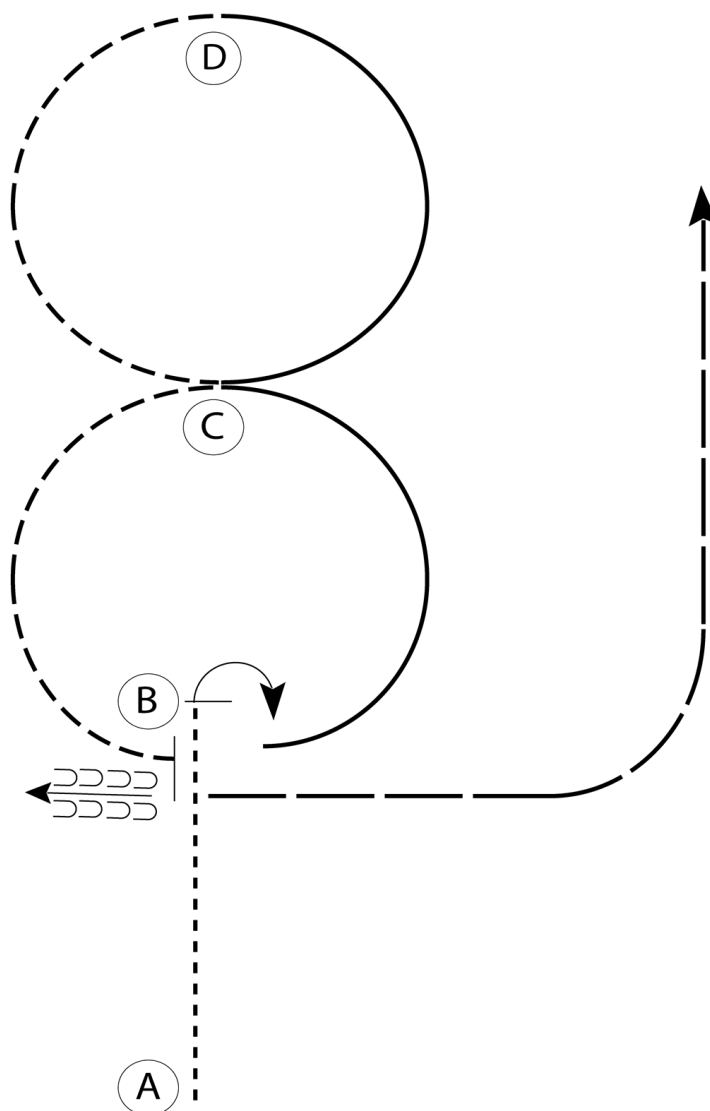

1. Walk from A to B
2. At B stop and perform a 90 turn on the forehand to the right
3. Canter on the left lead to C
4. Posting trot from C to D
5. At D canter on the right lead to C
6. Posting trot from C to B
7. At B stop and back one horse length
8. Hand gallop to the exit

Walk	-----
Trot	- - - - -
Extended Trot	-----
Canter	—————
Leg Yield	
Lead Change	— / —
Back	← ← ← ← ←
Marker	Ⓚ
Sidepass	← — — — — →
Hand Gallop	—————

[HSE/1-26]

Pattern Provided by:

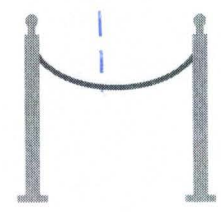
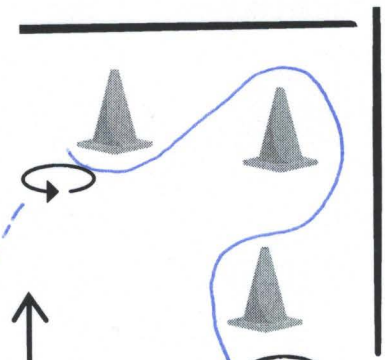
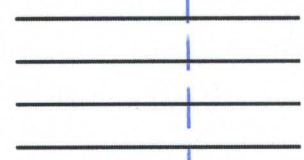
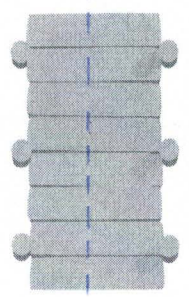
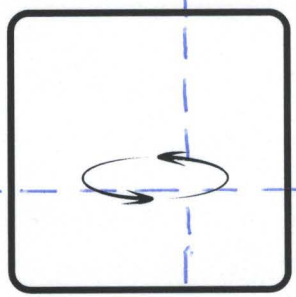
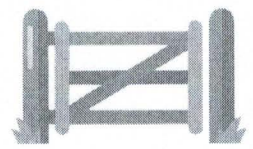
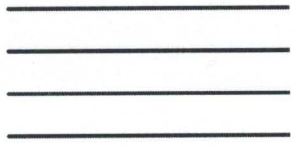
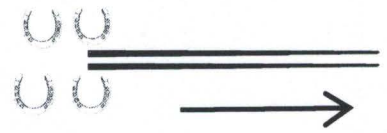

▲ Start

In Hand Trail

X End

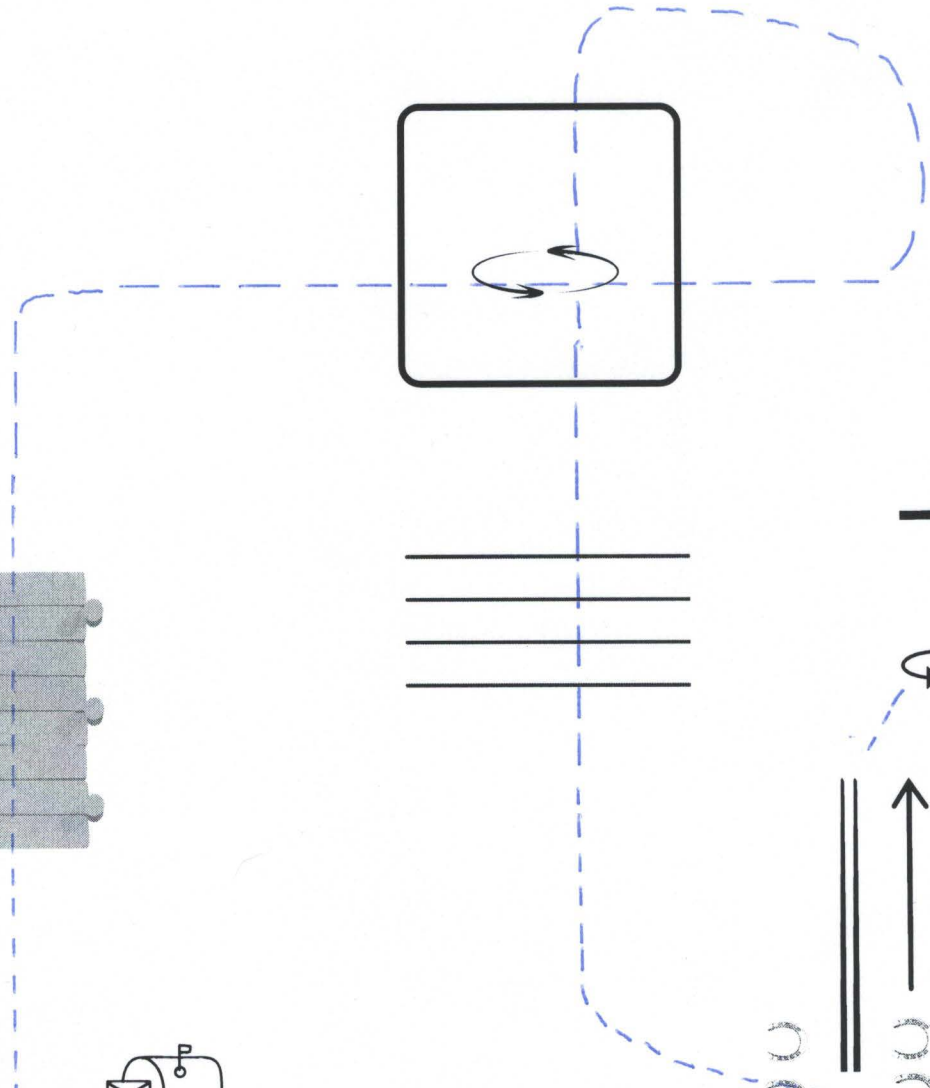

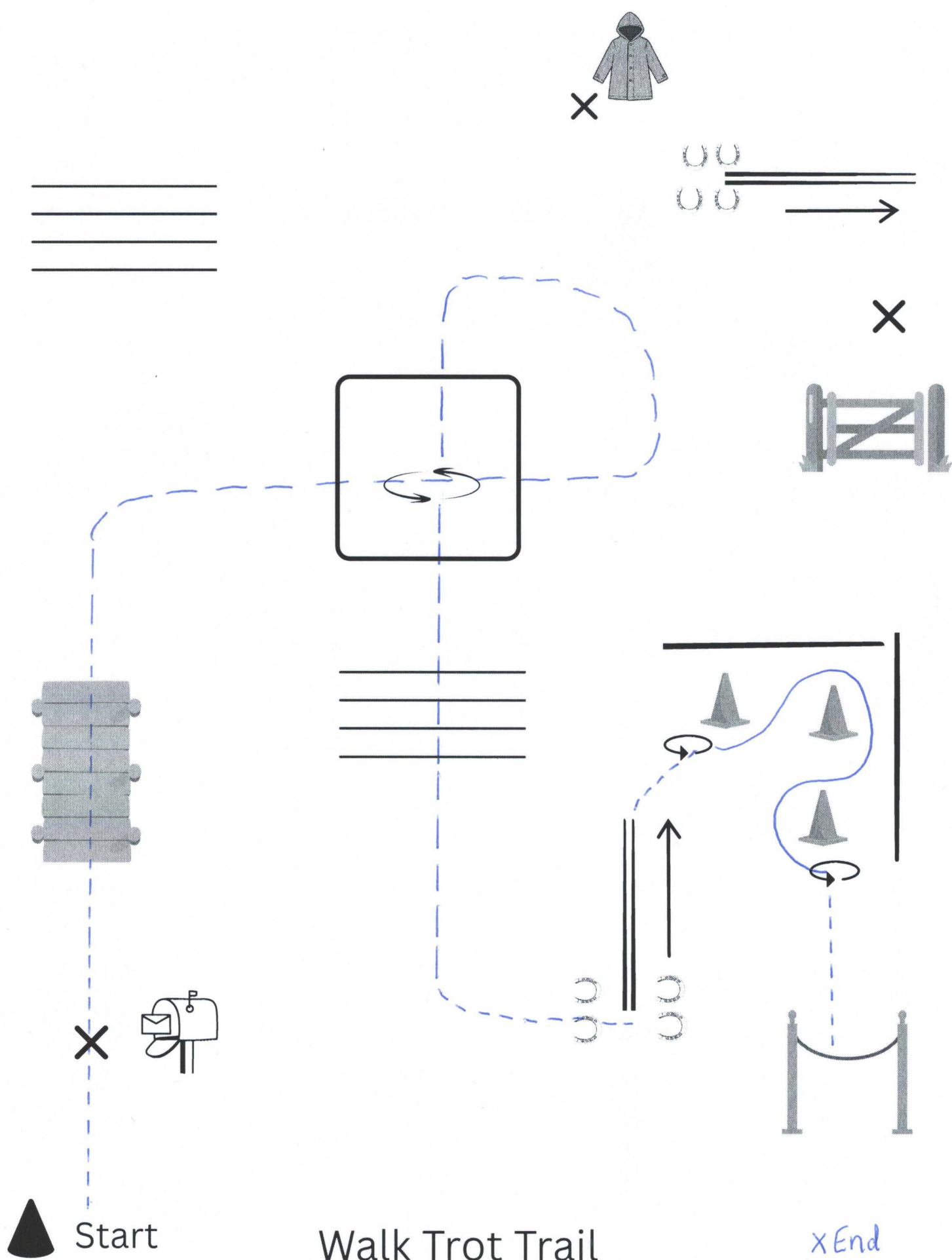

Start

Walk Trot Trail

xEnd

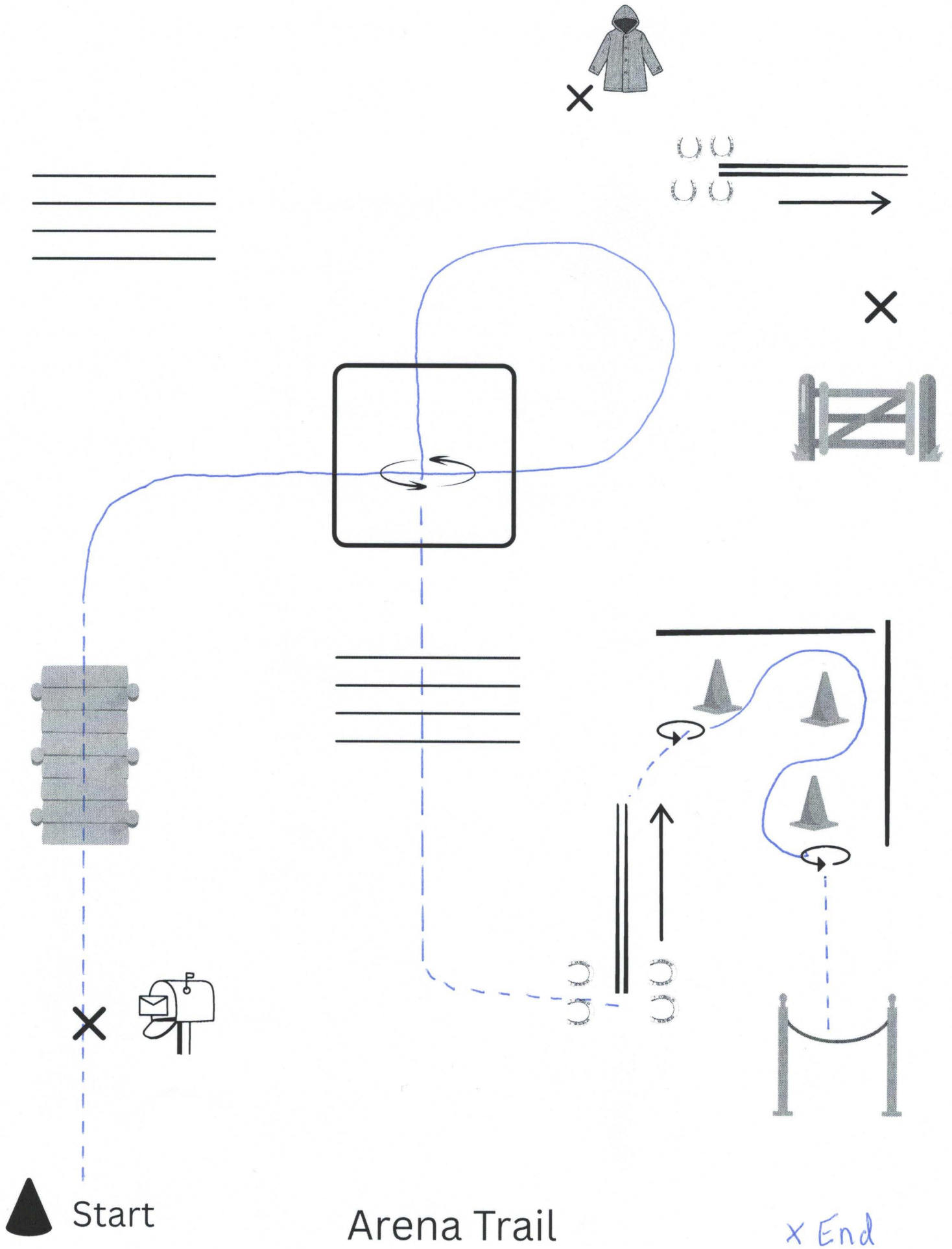

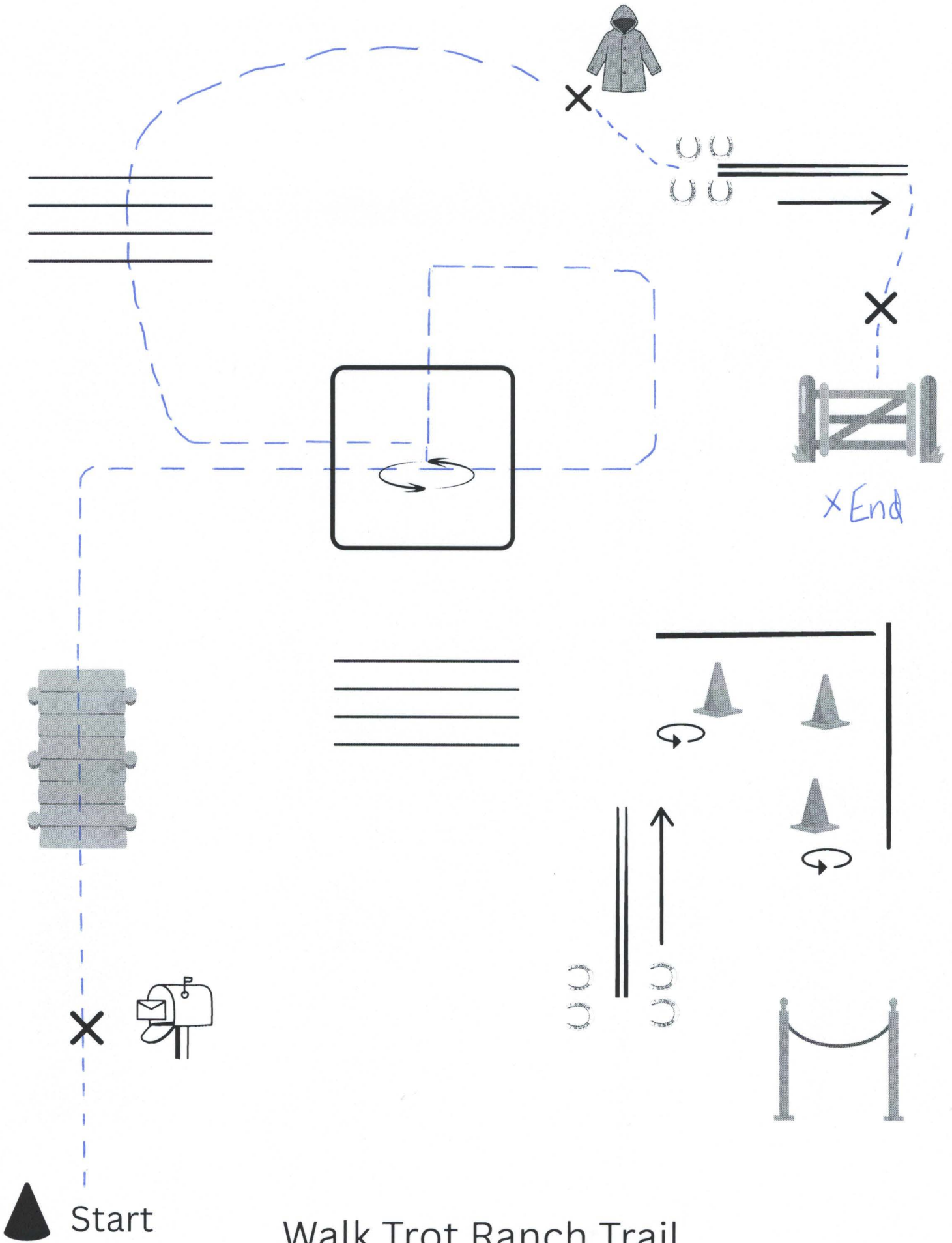

Walk Trot Ranch Trail

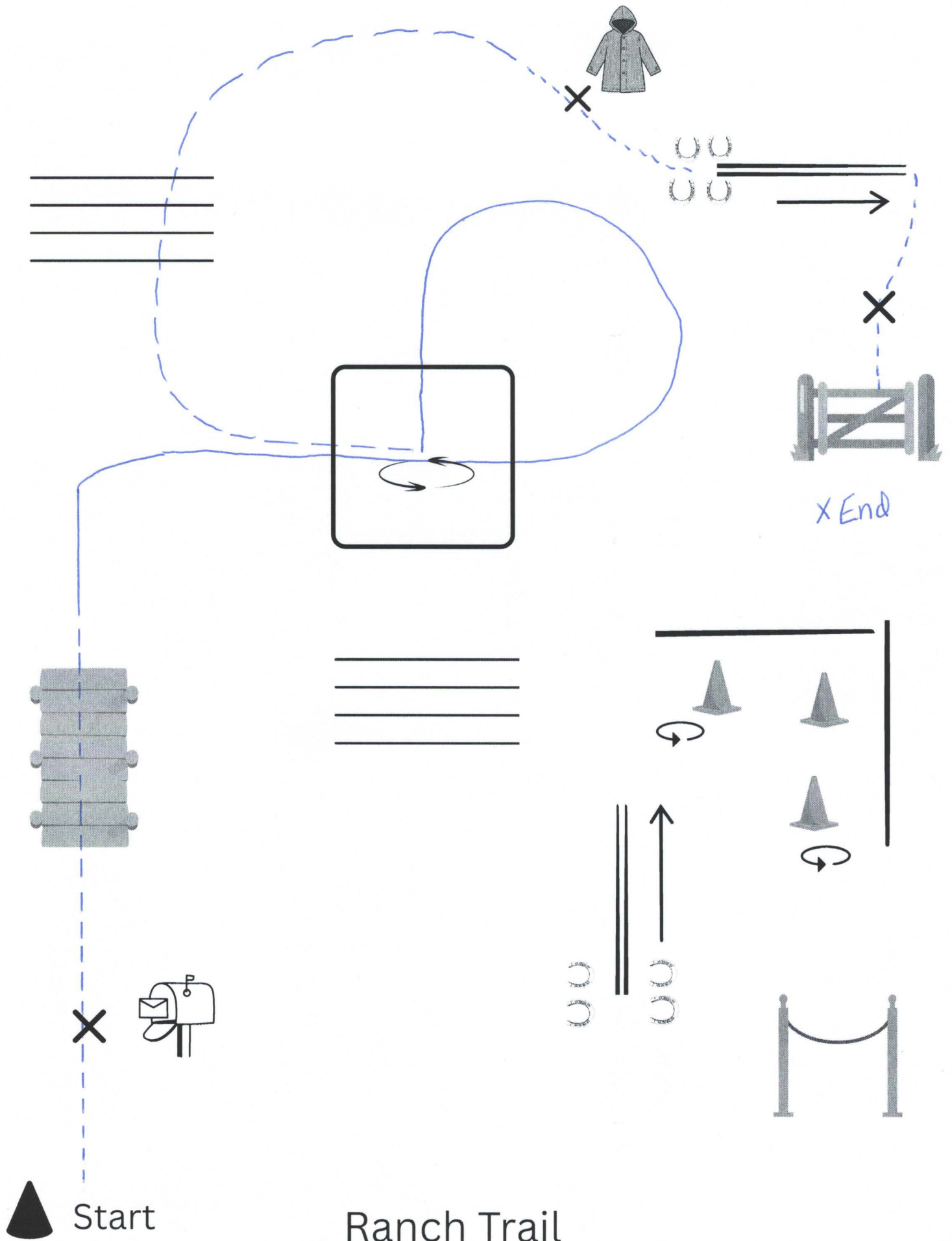

Ranch Trail

SPOTTED SPRING SPECTACULAR 2026

ALL TRAIL INSTRUCTIONS

In Hand Trail

1. Walk to mailbox, remove mail, show judge, return mail and close box.
2. Walk to and over bridge.
3. After bridge trot to and through box, up and around returning to the box.
4. Stop in box, perform a 360-degree turn, trot out of box and over the 4 poles.
5. Walk up to the elevated sidepass, and sidepass to the left.
6. After the sidepass walk to the back through, perform a 180-degree turn and back through the serpentine. Perform another 180-degree turn to end facing the rope gate.
7. Walk to the gate and work the gate with your left hand. Pattern complete

Walk Trot Trail

1. Walk to mailbox, remove mail, show judge, return mail and close box.
2. Walk to and over bridge.
3. After bridge trot to and through box, up and around returning to the box.
4. Stop in box, perform a 360-degree turn, trot out and over the 4 poles.
5. Walk up to the elevated sidepass, and sidepass to the left.
6. After the sidepass walk to the back through, perform a 180-degree turn and back through the serpentine. Perform another 180-degree turn to end facing the rope gate.
7. Walk to the gate and work the gate with your right hand. Pattern complete.

Arena Trail

1. Walk to mailbox, remove mail, show judge, return mail and close box.
2. Walk to and over bridge.
3. After bridge lope on the right lead to and through box, up and around returning to the box.
4. Stop in box, perform a 360-degree turn, trot out and over the 4 poles.
5. Walk up to the elevated sidepass, and sidepass to the left.
6. After the sidepass walk to the back through, perform a 180-degree turn and back through the serpentine. Perform another 180-degree turn to end facing the rope gate.
7. Walk to the gate and work the gate with your right hand. Pattern complete.

Ranch Walk Trot Trail

1. Walk to mailbox, remove mail, show judge, return mail and close box.
2. Walk to and over bridge.
3. After bridge trot to and through box, up and around returning to the box.
4. Stop in box, perform a 270-degree turn, trot out and over the 4 poles.
5. After the poles, extend the trot all the way to the slicker and then halt.
6. Pick up the slicker, put it on, take it off and put it back.
7. Walk to the elevated sidepass, sidepass to the left.
8. Walk half way between the sidepass and the gate. Halt and dismount.
9. Walk up to gate, work gate with your Right hand while going through the gate on the ground. Pattern complete.

Ranch Trail

1. Walk to mailbox, remove mail, show judge, return mail and close box.
2. Walk to and over bridge.
3. After bridge lope on the right lead to and through box, up and around returning to the box.
4. Stop in box, perform a 270-degree turn, trot out and over the 4 poles.
5. After the poles, extend the trot all the way to the slicker and then halt.
6. Pick up the slicker, put it on, take it off and put it back.
7. Walk to the elevated sidepass, sidepass to the left.
8. Walk half way between the sidepass and the gate. Halt and dismount.
9. Walk up to gate, work gate with your Right hand while going through the gate on the ground. Pattern complete.