

APOLLO

MULTIGYM

With a proven history of durability and performance, the APOLLO is becoming a favorite of correctional facilities as well as busy outdoor fitness park installations.



Real Fitness Equipment for Real Results

The APOLLO Multigym takes the basics of indoor commercial fitness equipment and delivers it to the outside world in a tamperproof, durable, and weatherproof package.

Compact, cost effective, and completely safe, the APOLLO is designed for any fitness level or ability.

 **TAMPERPROOF.**  **WEATHERPROOF.**  **SAFE.**

POPULAR PULLEY STATION

The APOLLO features the popular HI-LO pulley station for a variety of standing or seated exercises. Our unique, tamperproof selectorized weight stack allows users to adjust weight between 10 and 100lbs. Locking safety features also eliminate pinch points or entrapment zones typically seen on selectorized weight stack systems.

19+ DIFFERENT EXERCISES

The APOLLO is designed with over 19 different exercises, offering a full body workout.

With adjustability where needed and our unique chin/dip assist mechanism, the APOLLO Multigym is suitable for users of all fitness levels.

5 SIMULTANEOUS USERS

The APOLLO helps you make the most of your space, with up to five people using the equipment at once.

The APOLLO is built to maximize indoor or outdoor exercise areas, with over 19 exercises available:



WATCH NOW
PRODUCT VIDEO
APOLLO MULTIGYM

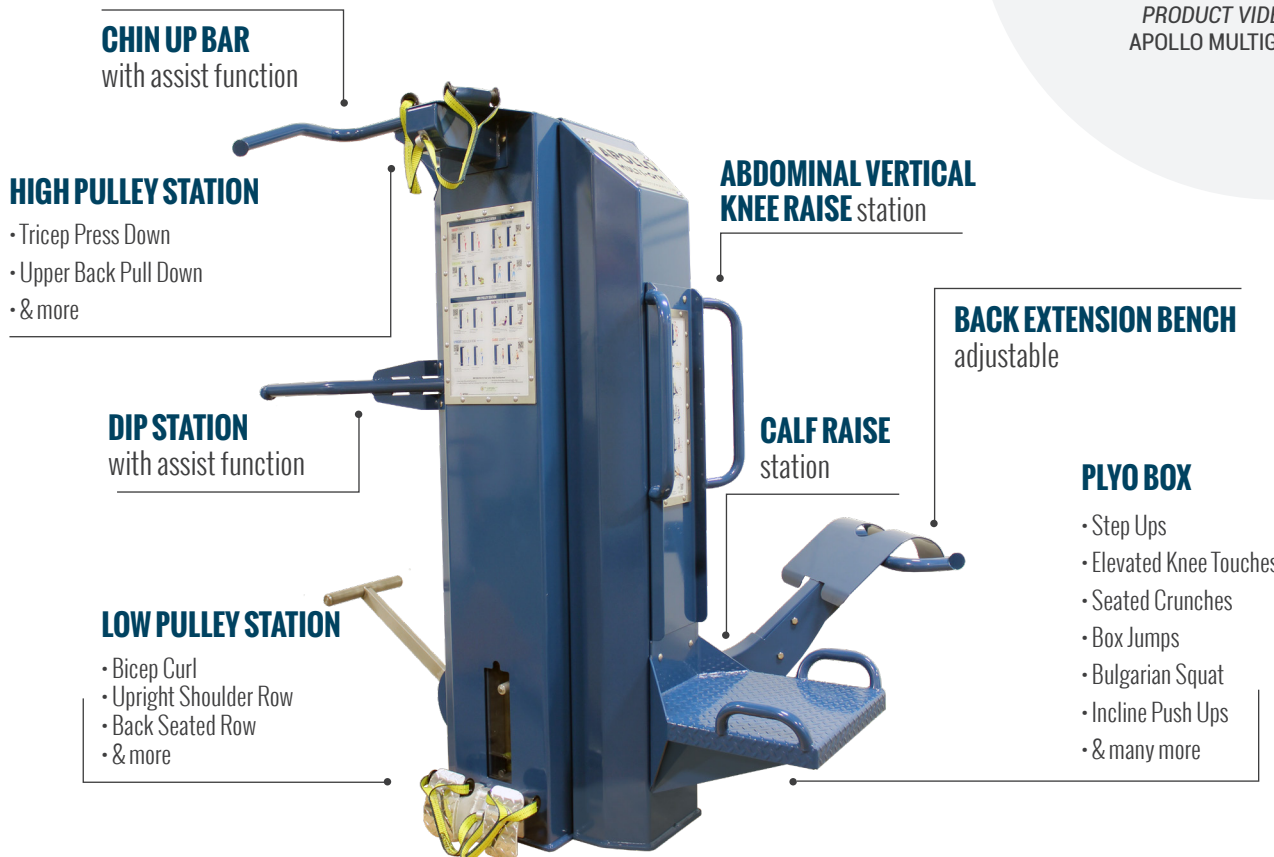

TECHNICAL SPECIFICATIONS



Width: 73" / 185 cm **Weight:** 1046 lbs / 475 kg
Length: 76" / 193 cm **Weight Stack Weight:**
Height: 85" / 216 cm 100 lbs / 45 kg



Anchoring Requirements: 4 x concrete anchors with rated "pull out" or "tension" strength of 3400lbs or greater. Anchors must be secured into structural concrete.

Frame & Finish: Constructed of 3/16" and 1/4" heavy duty steel that is zinc primed and polyester powder coated with UV stabilized color pigment. All fasteners are tamperproof stainless steel carriage bolts with the locking nuts on the inside of the padlocked center column.

Standard Color: Green Blue.
Custom colors available for an extra charge.

Shipping Weight: 1176 lbs / 534 kg

Shipping Dimensions: 48" wide x 72" long x 85" high /
122 cm wide x 183 cm long x 216 cm high

Number of Simultaneous Users: 5

CAD DRAWING

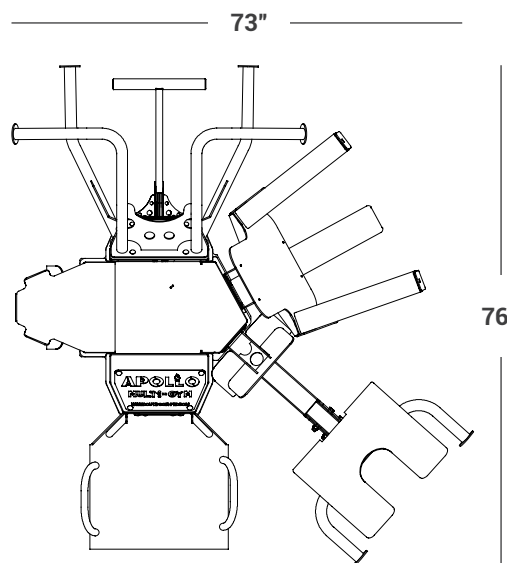

CLICK
FOR CAD DETAILS

APOLLO
MULTIGYM