

# OWNER'S MANUAL



## MANUAL OPERATED LEVER HOIST ALHC SERIES



### Capacity

**0.25 Ton through 0.75 Ton**

## WARRANTY INFORMATION AND TECHNICAL SERVICE

All products sold by Atlas Lifting & Rigging, LLC. are warranted to be free of defects in material and workmanship from date of shipment by Atlas Lifting & Rigging, LLC. If one of our products needs repair of service, please contact Technical Service at 1-833-ALR-LIFT, 8AM to 5PM Anywhere in the US, Monday through Friday.

### Warranty Period and Coverage

- ALR products carry a limited warranty of 2 years.
- Accessories carry a limited warranty of one year from the date of receipt.
- This warranty covers only the initial purchaser of the product from the date of delivery.
- This warranty covers any defects in workmanship or materials subject to the limitations stated below.
- This warranty does not cover failures due directly or indirectly to misuse, abuse, negligence or accidents, normal wear-and-tear, improper repair, alterations or lack of maintenance.

### Limitations on This Warranty

The product must be used in accordance to ALR recommendations. The product must not have been subjected to misused, abused, neglected, lack of maintenance, negligence or unauthorized repairs or alterations.

Should any defect in material or workmanship occur during the period stated above, the product will be inspected by ALR and at its discretion, ALR will either replace or repair the hoist in question free of charge and delivery F.O.B. Atlas Lifting & Rigging, LLC place of business or customer.

Customer must receive a Return Goods Authorization form from ALR or an Authorized ALR service center prior to shipping product for warranty evaluation. An explanation of the product issues must accompany the product. Product must be returned freight pre-paid. Upon repair, the product will be covered for the remainder of the original warranty period. Other restrictions apply. Please contact Technical Service for additional details of warranty restrictions. If it is determined that the product was misused, abused, neglected, used in a negligent manner or was subject to unauthorized repair or modification, the customer will be responsible for the cost of the return of the product.

Atlas Lifting & Rigging, LLC disclaims any and all other warranties of any kind expressed or implied as to the product's merchantability or fitness for a particular application. Atlas Lifting & Rigging, LLC will not be liable for death, injuries to persons or property or for incidental, contingent, special or consequential damages, loss or expense arising in connection with the use or inability whatever, regardless of whether damage, loss or expense results from any act by Atlas Lifting & Rigging, LLC whether negligent or willful, or from any other reason.

### Technical Support

Please contact Technical Service at 1-833-ALR-LIFT. **Please note that you will be asked to provide proof of initial purchase when calling.** If a product requires further inspection, the Technical Service representative will explain and assist with any additional action needed.

Table of Contents

<u>Section</u>	<u>Page Number</u>
1.0 Important Information and Warnings .....	4
1.1 Term and Summary .....	4
1.2 Shall's and Shall's Not's for Operation .....	4
2.0 Unpacking .....	5
2.1 Content of Carton .....	5
3.0 Pre-operation Inspection .....	5
4.0 Hoist Operation .....	6
4.1 Free Chain Principle .....	6
4.2 Lifting and Lowering Operation .....	6
4.3 Introduction .....	6
5.0 Care in Use .....	7
6.0 Maintenance & Inspection .....	7
6.1 Inspection .....	7
7.0 Storage of Hoist .....	9
8.0 Specifications .....	10
8.1 Stock Number .....	11
9.0 Installation .....	11
10.0 Operation .....	13
11.0 Precautions .....	14
12.0 Allowable Limits .....	15
12.1 Load Chain .....	15
12.2 Hooks (Top and Bottom) .....	15
13.0 Troubleshooting .....	16
14.0 Replacement Parts .....	16

# 1.0 Important Information and Warnings

## 1.1 Terms and Summary

This manual provides important information for personnel involved with the installation, operation and maintenance of this product.

Although you may be familiar with this or similar equipment, it is strongly recommended that you read this manual before installing, operating or maintaining the product.

**Danger, Warning, Caution and Notice** — Throughout this manual there are steps and procedures that can present hazardous situations.

The following signal words are used to identify the degree or level of hazard seriousness.

**!DANGER** Danger indicates an immediately hazardous situation which, if not avoided, **will result in death or serious injury**, and property damage.

**!WARNING** Warning indicates an imminently hazardous situation which, if not avoided, **could result in death or serious injury**, and property damage.

**!CAUTION** Caution indicates a potentially hazardous situation which, if not avoided, **may result in minor or moderate injury** or property damage.

**NOTICE** Notice is used to notify people of installation, operation, or maintenance information which is important but not directly hazard-related.

The operation of a hoist involves more than activating the hoist's controls. Per the ANSI/ASME B30 standards, the use of a hoist is subject to certain hazards that cannot be mitigated by engineered features, but only by the exercise of intelligence, care, common sense, and experience in anticipating the effects and results of activating the hoist's controls. Use this guidance in conjunction with other warnings, cautions, and notices in this manual to govern the operation and use of your hoist.

## 1.2 Shall's and Shall's Not's for Operation

### WARNING

Improper operation of a hoist can create a potentially hazardous situation which, if not avoided, could result in death or serious injury, and substantial property damage. To avoid such a potentially hazardous situation **THE OPERATOR SHALL:**

- **NOT** use hoist before reading Owner's Manual.
- **NOT** lift more than rated load for the hoist.
- **NOT** operate hoist when it is restricted from forming a straight from hook to hook in the direction of loading.
- **NOT** use hoist with twisted, damaged, or worn chain.
- **NOT** use damaged hoist or hoist that is not working properly.
- **NOT** use the hoist to lift, support, or transport people.
- **NOT** lift loads over people.
- **NOT** use hoist with extension on lever handle.
- **NOT** remove or obscure the warnings on the hoist.
- **NOT** use load chain as a sling or wrap load chain around load.
- **NOT** use in a way that causes either hook to be side loaded.
- **NOT** apply the load to the tip of the hook or to the hook latch.
- **NOT** use hoist if hook latch is missing or malfunctioning.
- **NOT** apply load unless load chain is properly seated in the load sheave.
- **NOT** use the hoist in such a way that could result in shock or impact loads being applied to the hoist.
- **NOT** attempt to lengthen the load chain or repair damaged load chain.
- **NOT** operate beyond the limits of the load chain travel.
- **NOT** operate hoist with missing/damaged chain stopper.
- **NOT** leave load supported by the hoist unattended unless specific precautions have been taken.
- **NOT** allow the chain, or hook to be used as an electrical or welding ground.
- **NOT** allow the chain, or hook to be touched by a live welding electrode.
- **NOT** operate a hoist on which the safety placards or decals are missing or illegible.
- Be familiar with operating controls, procedures, and warnings.
- Make sure the unit is securely attached to a suitable support before applying load.
- Make sure load slings or other approved single attachments are properly sized, rigged, and seated in the hook saddle.
- Take up slack carefully - make sure load is balanced and load-holding action is secure before continuing.
- Make sure all persons stay clear of the supported load.
- Protect the hoist's load chain from weld splatter or other damaging contaminants.
- Report Malfunctions or unusual performances (including unusual noises) of the hoist and remove the hoist from service until the malfunction or unusual performance is resolved.
- Warn personnel before lifting or moving a load.
- Warn personnel of an approaching load.

### !CAUTION

Improper operation of a hoist can create a potentially hazardous situation which, if not avoided, could result in minor or moderate injury, or property damage. To avoid such a potentially hazardous situation **THE OPERATOR SHALL:**

- Maintain a firm footing or be otherwise secured when operating the hoist.
- Check brake function by tensioning the hoist prior to each lift operation.
- Use hook latches. Latches are to retain slings, chains, etc. Under slack conditions only.
- Make sure the hook latches are closed and not supporting any parts of the load.
- Make sure the load is free to move and will clear all obstructions.
- Avoid swinging the load or hook.
- Make sure hook travel is in the same direction as shown on controls.
- Inspect the hoist regularly, replace damaged or worn parts, and keep appropriate records of maintenance.
- Use the hoist manufacturer's recommended parts when repairing the unit.
- Lubricate load chain per hoist manufacturer's recommendations.
- NOT** allow your attention to be diverted from operation the hoist.
- NOT** allow the hoist to be subjected to sharp contact with other hoists , structures, or objects through misuse.
- NOT** adjust or repair the hoist unless qualified to perform such adjustments or repairs.

## 2.0 UNPACKING

Open carton and check for shipping damage. Report any damage immediately to your distributor and shipping agent. Do not discard any shipping material until the Lever Hoist is assembled and running properly. Read this entire instruction manual thoroughly for set-up, maintenance and safety instructions.

### 2.1 CONTENT OF CARTON

- 1 Lever Operated Lever Hoist
- 1 Owner's Manual
- 1 Test certificate

## 3.0 PRE-OPERATION INSPECTION

Your ALR Lever HOIST has been tested and conforms to ANSI/ASME B30.21 and HST-3 standards.

On completion of installation, but prior to your ALR Lever Hoist being put into regular service, the following procedures should be carried out:

1. Check that all joints and fasteners are tight and secure.
2. Operate the hoist with both no load and full load, and check that the operation is smooth at all times.
3. Check operation of hoist brake, under light load and full load conditions.
4. Traveling units - run throughout the full extent of the runway, ensuring adequate clearance at all times.
5. Please ensure your ALR Test Certificate has been stored and the unit(s) have been placed in your lifting register for future reference.

## 4.0 Hoist Operation

### 4.1 Free Load Chain Principle

- 1) Free chaining allows the load chain to be moved freely because the brake is released under no load situation.
- 2) Pulling the Hand Wheel #5 actuates the Twisting Spring 1 #6 to release the mechanical brake allowing the load chain to be pulled in either direction to the desired length.
- 3) The brake is engaged during lowering or lifting the load.

**4.2 Lifting and Lowering Operation** - Operating the Lever Handle with the Selector Lever set to the lifting "UP" or the lowering "DN" position, the lever hoist performs as follows:

- 1) Set the Selector Lever to the direction of load movement desired and ratchet the Lever Handle #10 back and forth. Refer to Table 1.
- 2) In lifting mode, the mechanical brake is engaged and supports the load on the pawls when the Lever Handle #10 stops.
- 3) In lowering mode, Lever Handle #10 operation releases the mechanical brake and lowers the load, when the Lever Handle #10 stops, the mechanical brake is engaged and supports the load.
- 4) The brake is always engaged in the lifting and lowering modes.
- 5) If Lever handle #10 movement does not produce lifting, pull down the load side of the load chain while ratcheting until load chain is not slack.

Selector Position	Lever Rotation	Load Movement
UP	Clockwise	Lift
DN	Counter clockwise	Lower

### 4.3 Introduction



MANUAL OPERATED LEVER HOIST OPERATORS SHALL BE REQUIRED TO READ THE OPERATION SECTION OF THIS MANUAL, THE WARNINGS CONTAINED IN THIS MANUAL, INSTRUCTION AND WARNING LABELS ON THE HOIST OR LIFTING SYSTEM, AND THE OPERATION SECTIONS OF ANSI/ASME B30.21 AND ASME B30.10. THE OPERATOR SHALL ALSO BE REQUIRED TO BE FAMILIAR WITH THE MANUAL Lever Hoist AND HOIST CONTROLS BEFORE BEING AUTHORIZED TO OPERATE THE HOIST OR LIFTING SYSTEM.

MANUAL OPERATED LEVER HOIST OPERATORS SHOULD BE TRAINED IN PROPER RIGGING PROCEDURES FOR THE ATTACHMENT OF LOADS TO THE HOIST HOOK.

MANUAL OPERATED LEVER HOIST OPERATORS SHOULD BE TRAINED TO BE AWARE OF POTENTIAL MALFUNCTIONS OF THE EQUIPMENT THAT REQUIRE ADJUSTMENT OR REPAIR, AND TO BE INSTRUCTED TO STOP OPERATION IF SUCH MALFUNCTIONS OCCUR, AND TO IMMEDIATELY ADVISE THEIR SUPERVISOR SO CORRECTIVE ACTION CAN BE TAKEN.

HOIST OPERATORS SHOULD **NOT** HAVE A HISTORY OF OR BE PRONE TO SEIZURES, LOSS OF PHYSICAL CONTROL, PHYSICAL DEFECTS, OR EMOTIONAL INSTABILITY THAT COULD RESULT IN ACTIONS OF THE OPERATOR BEING A HAZARD TO THE OPERATOR OR TO OTHERS.

HOIST OPERATORS SHOULD **NOT** OPERATE A HOIST OR LIFTING SYSTEM WHEN UNDER THE INFLUENCE OF ALCOHOL, DRUGS, OR MEDICATION.

## NOTICE

- . Read ANSI/ASME B30.21 and ANSI/ASME B30.10.
- . Read the Owner's Manual.
- . Read all warning labels and tag attached to Lever Hoist.

## 5.0 CARE IN USE

1. Always examine the hoist carefully prior to use - your life and others may be at risk. Look for cracks or damage, particularly with hooks and load chain.
2. Keep load chain clean and oiled to prevent undue damage or wear. When in use, avoid dragging the load chain through dirt or mud.
3. When the hoist is used outdoors or in a corrosive environment, ensure that it is regularly and adequately lubricated.
4. Do not operate the hoist if you do not have a clear view of the bottom hook and the load.

## 6.0 MAINTENANCE & INSPECTION

The maintenance instructions contained in this manual are intended as a guide to the necessary procedures to be carried out by competent and experienced personnel to prolong the service life of the unit. ALR Brands, do not accept responsibility either for the manner in which the instructions in this manual are observed or for any consequence thereof.

To maintain continuous and satisfactory operation, a regular inspection procedure must be initiated so that worn or damaged parts can be replaced before they become unsafe. The intervals of inspection must be determined by the individual application and are based upon the type of service to which the chain hoist will be subjected. The inspection of chain hoists is divided into two general classifications designated as frequent and periodic.

### 6.1 Inspection

#### General

The inspection procedure is based on ASME B30.21. The following definitions are from ASME B30.21 and pertain to the inspection procedure as follows.

**Personnel Competence** – Persons performing the functions identified in this volume shall meet the applicable qualifying criteria stated in this volume and shall through education, training, experience, skill, and physical fitness, as necessary, be competent and capable to perform the functions as determined by the employer or employer's representative.

**Qualified Person** – A person, who by possession of a recognized degree or certificate of professional standing, or who, by extensive knowledge, training, and experience, has successfully demonstrated the ability to solve or resolve problems relating to the subject matter and work.

**Normal Service** – that distributed service which involves operation with randomly distributed loads within the rated load limit, or uniform loads less than 65% of rated load for more than 15% of the time.

**Heavy Service** – that service which involves operation within the rated load limit which exceeds normal service.

**Severe Service** – that service which involves normal or heavy service with abnormal operating conditions.

#### Inspection Classification

**Initial Inspection** – Prior to initial use, all new, altered or modified hoists shall be inspected per the Frequent Inspection criteria.

**Inspection Classification** – the inspection procedure for hoists in regular service is divided into 3 general classifications based on the intervals which inspection should be performed. The intervals in turn depends on the nature of the critical components of the hoist and the degree of their exposure to wear, deterioration, or malfunction. The 3 general classifications are designated as **Preoperational Frequent** and **Periodic**.

**Preoperational Inspection** – Visual inspection performed before the first use of each shift with records not required.

**Frequent Inspection** – Visual examinations by the operator or designated person with intervals per the following criteria.

- 1) Normal service – monthly
- 2) Heavy service – weekly to monthly
- 3) Severe service – daily to weekly
- 4) Special or infrequent service – as recommended by a qualified person before and after each occurrence.

**Periodic Inspection** – Visual inspection by a designated person with intervals per the following criteria.

- 1) Normal service – monthly
- 2) Heavy service – weekly to monthly
- 3) Severe service – daily to weekly
- 4) Special or infrequent service – as recommended by a qualified person before and after each occurrence.

**Preoperational Inspection** – Visual inspection shall be made before the first use of each shift with records not required

- 1) All functional operating mechanisms for proper operation and adjustment, maladjustment and unusual sounds.
- 2) Hooks and safety latches in accordance with ASME B30.10

**Frequent Inspection** – Inspection should be made on a frequent basis as follows. Frequent inspections are observations made during operation for any defects or damage that may appear between period inspections. Evaluation and resolution of the results of frequent inspection shall be made by a designated person so that the Lever Operated Lever Hoist is maintained in a safety working condition.

- 3) All functional operating mechanisms for proper operation and adjustment, maladjustment and unusual sounds.
- 4) Lever Operated Lever Hoist brake system for proper operation.
- 5) Hooks and safety latches in accordance with ASME B30.10
- 6) Safety latches operation

**Periodic Inspection** – Inspection should be made on a periodic basis as follows. Evaluation and resolution of the results of periodic inspection shall be made by a designated person so that the Lever Operated Lever Hoist is maintained in safety working condition.

For inspections where load suspension parts of the hoists are disassembled, a load test per ASME B30.21 must be performed on the Lever Operated Lever Hoist after it is re-assembled and prior to its return to service.

- 1) Requirements of frequent inspection
- 2) Evidence of loose bolts & nuts.
- 3) Evidence of worn, corroded, cracked or distorted parts, such as hook, load pin, gears load chain.
- 4) Evidence of damaged or excessive wear of load sheave and idle heaves.
- 5) Evidence of worn or old contaminated friction discs, worn pawls & ratchet.
- 6) Nameplate on Lever Hoist is illegible.
- 7) End connection of load chain.

**Occasionally Use Hoist** – Lever Hoists are used infrequently shall be inspected as follows prior to placing in service.

- 1) Hoist idle more than 1 month but less than 1 year: Inspect per Frequent Inspection criteria.
- 2) Hoist idle more than 1 year: Inspect per Periodic Inspection criteria.

#### **Inspection Methods and Criteria**

- 1) The items are based on those listed in ASME B30.21 for the Frequent and Periodic Inspection.
- 2) Frequent Inspection – NOT intended to involve disassembly of the Lever Operated Lever Hoist. Disassembly for further inspection would be required only if Frequent Inspection results so indicate. Disassembly for further inspection should only be performed by a qualified person trained in the disassembly and re-assembly of the Lever Operated Lever Hoist.
- 3) Periodic Inspection – Disassembly of the Lever Hoist is required. Disassembly for further inspection should only be performed by a qualified person trained in the disassembly and re-assembly of the Lever Operated Lever Hoist.

Parts should be from ALR or ALR's Service Agents. Using 'commercial' or other manufacturer's parts to repair the ALR Lever Hoist may cause load loss. [www.alrlift.com](http://www.alrlift.com) or [info@alrlift.com](mailto:info@alrlift.com)

**WARNING - TO AVOID INJURY** - Use only ALR supplied replacement parts. Parts may look alike, but ALR parts are made of specific materials or processed to achieve specific properties.



## 7.0 STORAGE OF HOIST

Note: Always store unit in a clean and dry area. Ensure that all repair and maintenance work is carried out by qualified personnel, using only the specified genuine parts from ALR.

If there are any questions or comments, please contact either your local supplier or ALR. ALR can also be reached at our web site: [www.ALRLIFT.com](http://www.ALRLIFT.com) or telephone at 1-833-ALR-LIFT.

The ALR ALHC-Series Lever Hoists comply with ANSI/ASME B30.21 and HST-3 standards.

Record your purchase information here for quick reference:

Model No.:	Stock No.:	Serial No.:
Purchased From:		Date Purchased:

## 8.0 Specifications **(DRAWING IS INCORRECT – PART NUMBER IS WRONG)**

AMLH Series Lever Operated Lever Hoist

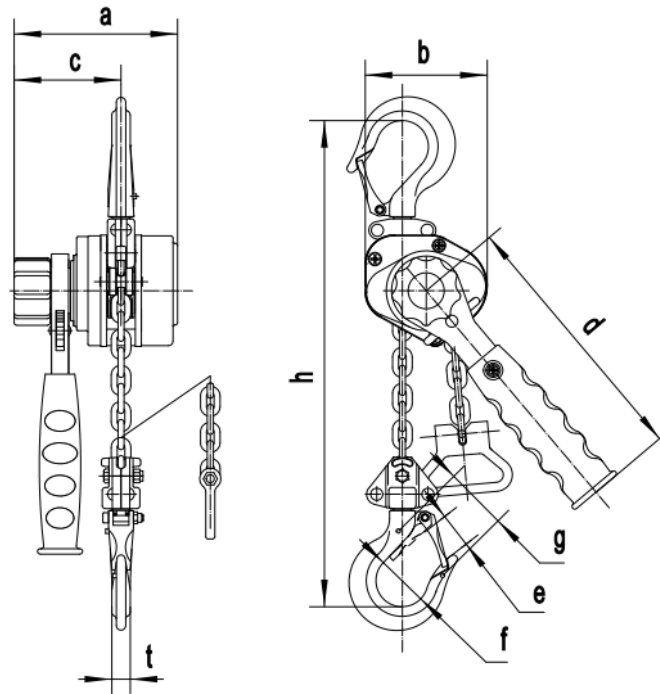

ALHC Series Lever Operated Lever Hoist

Capacity	(tonnes)	1/4	1/2	3/4	
Stock Number		ALHC-0025-05	ALHC-0050-05	ALHC-0075-05	
No. of Falls		1	1	1	
Load Chain Grade 100	(mm)	3.2×9	4.3×12	5×15	
Pull to Rated Load	(N)	178	324	373	
Pull to Rated Load	(lbsf)	40	72.8	83.9	
Proof Load	(lbsf)	825	1650	2475	
Standard Lift	(ft)	5	5	5	
Net Weight	(lbs)	3.31	4.85	7.5	
Dimensions	a	(mm)	87	100.5	105
	b	(mm)	76	96	92
	c	(mm)	55.5	62.5	64
	d	(mm)	145	160	180
	e	(mm)	21	24.5	28.5
	f	(mm)	32	34.5	35.5
	g	(mm)	35.5	42	41.5
	h	(mm)	200	250	260
t	(mm)	11	12	14	

NOTE: The above stock numbers are representative; chain is available in other lengths. Specify length when ordering.

## 8.1 Stock Number

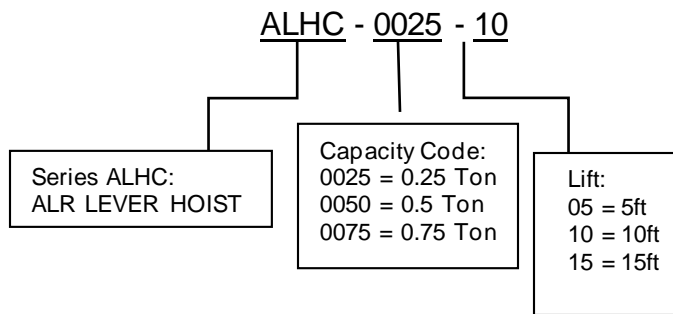

## 9.0 Installation

Support for the hoist may be hook, clevis pin, trolley, or beam clamp. Whatever method of suspension is chosen, the support components must be rated equal to, or greater than the capacity of the lever hoist. Supporting structures (such as I-Beams, etc.) should be installed by properly licensed professional installers.



Figure 1  
Features and terminology

## Pre-Operation Inspection

### Inspecting the Load Chain

1. A Chain Stop #37 must be attached to the last link on the slack end of the chain. See Figure 2.

**WARNING** Do not operate the hoist with a twisted, kinked or damaged chain. Do not splice the chain.

2. Check that the chain does not twist along its length from hoist to hook. If twist is present on units with multiple falls, the hook must be passed back through the chain loop to remove all twist in the chain.
3. Replace the chain if links are stretched too long or seriously worn on the surface, especially at the points where links contact each other. See "Allowable Limits" on page 15 for measuring chain elongation.
4. Do not use a chain that is seriously rusted or cracked.
5. Periodically apply a light coat of 30-weight oil to the chain. This will create easier operation and prolong the chain's life. For optimum results, clean the chain with an acid-free solution before oiling.



Figure 2

**WARNING** The load chain supplied with your ALR lever hoist is designed, manufactured, and tested for proper fit and durability. If chain should ever need replacing, for your own safety use factory replacement chain only. Use of other than factory replacement chain may cause serious injury and/or damage to the lever hoist.

Never extend load chain by welding a second piece to the original.

## Inspecting Hooks

It is important to check top and bottom hooks for proper opening and other signs of deformation or damage. Replace a hook immediately if any of the following problems are identified:

- The safety latch no longer contacts the hook opening.
- The vertical angle at the neck of the hook reaches  $10^\circ$  (see Figure 3).
- Chemical corrosion or cracks on the hook.
- Excessive wear on the inside surface.
- The throat opening has enlarged. (See page 15 for the maximum allowable limits for the throat opening.)

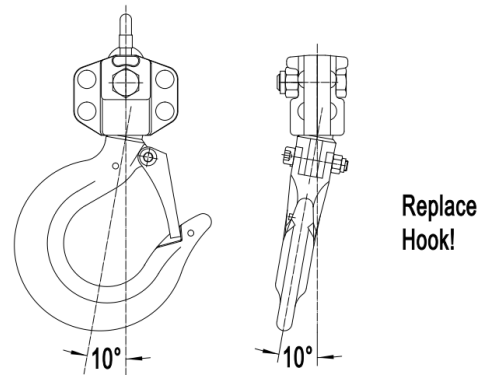

Figure 3

**⚠ WARNING** Do not attempt repair of a hook by heat treating, bending or attaching anything by welding. Such procedures will weaken and may cause failure of the hook.

## Other Inspections

1. Check for appropriate clicking sounds: With the selector lever in UP position, there will be a clicking sound when the lever handle is rotated in *either direction*. When the selector lever is in DOWN position, there will be a clicking sound only when the lever handle is ratcheted back into position but not as the load is lowered. If these sounds are not present, or if *irregular* clicking noises develop, do not use the hoist – have it inspected and repaired by an authorized service center.
2. If the lever hoist has not been used for an extended period of time, check for proper operation before putting into service.
3. The brake mechanism must be kept clean and free from dirt, water, and oil. Never allow oil to penetrate the braking mechanism. The brake should not slip while using the hoist.

## 10.0 Operation

The ALHC Lever Hoist may be used either in vertical position as a hoist; or in angled or horizontal position as a puller. Below is the general procedure for operating the hoist:

1. Set the top hook securely.
2. Correctly center the load on the bottom hook (Figure 4). Incorrect loading is dangerous to the operator, the lever hoist, and the load.
  - Never load the hook in front of the safety latch (A, Figure 5).
  - Never load the hook tip (B, Figure 5).
  - Never load the hook off the centerline (C, Figure 5).
  - Never load the hook sideways (D, Figure 5).
3. Move selector switch to the UP position. Ratchet the lever to raise or pull the load. Do not overload the lever hoist.

**⚠ WARNING** Do not touch the Hand Wheel #5 while lifting or lowering. Do not operate freewheel mode while there is a load on the hoist.

4. To release or lower the load, turn selector switch on the handle to the DN position and ratchet the handle.

NOTE: If the chain is pulled too suddenly in free-wheel mode, the brake may set preventing further pulling. Re-set the hoist by repeating step number 4 above, and then set the hoist back into freewheel mode to continue the operation.

Avoid lifting one load with two hoists. If this is unavoidable, apply equal weight to both hoists and use hoists with the proper lift capacity. **Capacity of each hoist must be equal to the total load to be lifted.**

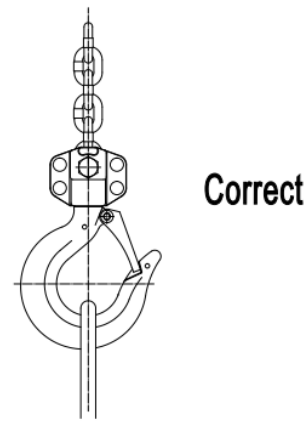

Figure 4

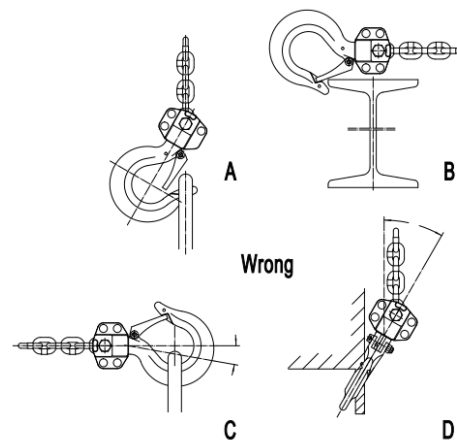

Figure 5

## 11.0 Precautions

- During lifting operations, do not stand under the load.
- Do not use any extension on the lever handle. Do not use your foot to apply pressure to the lever handle.
- Prevent the chain from dragging over sharp edges or corners. This will cause links to weaken, bend, or break.
- When connecting to a wire rope sling, the lever hoist must be applied along a straight line parallel to the surface on which it is resting. See Figure 6.
- When lifting loads, hook the load with slings. **Do not use the lever hoist chain as a sling** (Figure 7).
- Both ends of a sling or rope must be completely on the inside of the safety latch before pulling or lifting the load. Do not put one end on the inside of the latch and leave the other end on the hook end outside the latch.

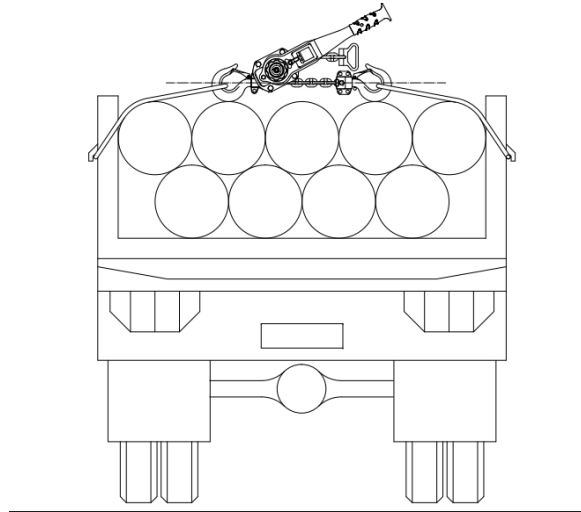

Figure 6

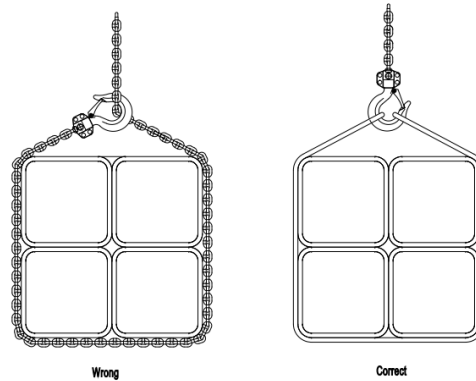
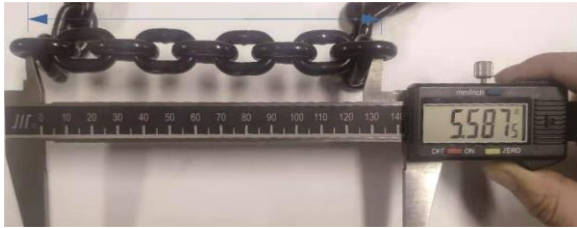

Figure 7

## 12.0 Allowable Limits

### 12.1 Load Chain

Carefully inspect the entire load chain. As illustrated in Figure 8, measure five consecutive links with calipers to find the length. Compare the results with the table in Figure 8. Check every three feet and especially where excessive wear is indicated. Any load chain that shows noticeable deformation or heat influence must be replaced with a new load chain.



Hoist Capacity	9 Links Normal (mm)	9 Links Limit Replace if $\geq$
0.25 ton	3.19"	3.29"
0.5 ton	4.25"	4.38"
0.75 ton	5.31"	5.47"

Figure 8

### 12.2 Hooks (Top and Bottom)

Replace the hook when the distance between indicator points – “A” in Figure 9 – is wider than the limits given in the table.

Never heat treat the hook or attach anything to the hook by welding.

Hoist Capacity	“A” Dimension Normal (mm)	“A” Dimension Replace if $\geq$
0.25 ton	1.4"	1.54"
0.5 ton	1.65"	1.81"
0.75 ton	1.63"	1.79"

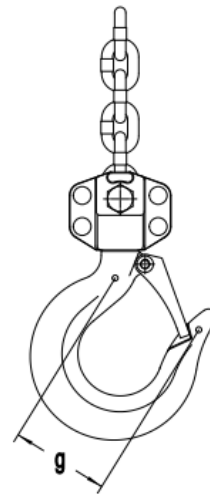

Figure 9

**13.0 Troubleshooting (THERE IS A LARGE EMPTY AREA ABOVE THIS. CONSIDER MOVING INFORMATION UPWARD)**

The numbers in parentheses refer to the parts breakdown on the following page.

Trouble	Probable Cause	Remedy*
Hoist will not lift (no clicking sound).	Pawl (#15) not engaging ratchet disc (#17); possible dirt or foreign material.	Clean and lubricate pawl/ratchet disc assemblies.
	Pawl spring (#14) is damaged.	Replace pawl spring.
	Selector switch spring is loose or damaged.	Tighten or replace selector switch spring.



Trouble	Probable Cause	Remedy*
Load slips or drifts while being lowered.	Dirt/corrosion/foreign material in hoist components.	Inspect and correct problem. Keep hoist clean and lubricated.
	Brake is slipping. Disc Hub (#33) is worn from long-term use, or is damaged from overloading or misuse.	Replace disc hub. Do not overload hoist.
Hoist will not lower load.	The brake has caught. (Hoist was left under load condition for extended period, or was shock-loaded while operating.)	Place selector lever in DN position and pull hard on the lever handle to re-set the brake. Resume operation.
	Brake components are corroded or damaged.	Replace components as needed; keep hoist clean and lubricated.
Hoist will not freewheel.	Brake has caught because load chain was pulled too hard.	Reset by rotating hand wheel clockwise while pulling down on load chain. Return hoist to freewheel mode and continue. Pull load chain less forcibly.

\* Any disassembly or repair of the lever hoist should be performed by properly trained personnel. Call ALR, or go to [ALRLIFT.com](http://ALRLIFT.com) to find an authorized Service Center nearest you.

## 14.0 Replacement Parts

When ordering Parts, please provide the Hoist model number, and serial number located on the hoist name plate (see Figure 10 below).

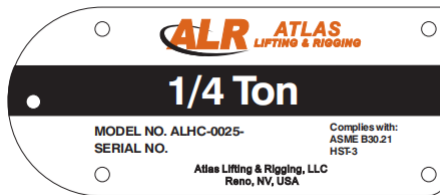

Figure 10 ALHC Name Plate

## Lever Hoist Parts

Replacement parts are listed on the following pages.

To order parts or reach our service department, call 1-833-ALR-LIFT, 8:00 TO 5PM, Monday through Friday. Having the Model Number and Serial Number of your lever hoist available when you call will allow us to serve you quickly and accurately.

# ALHC Lever Hoist Parts Break

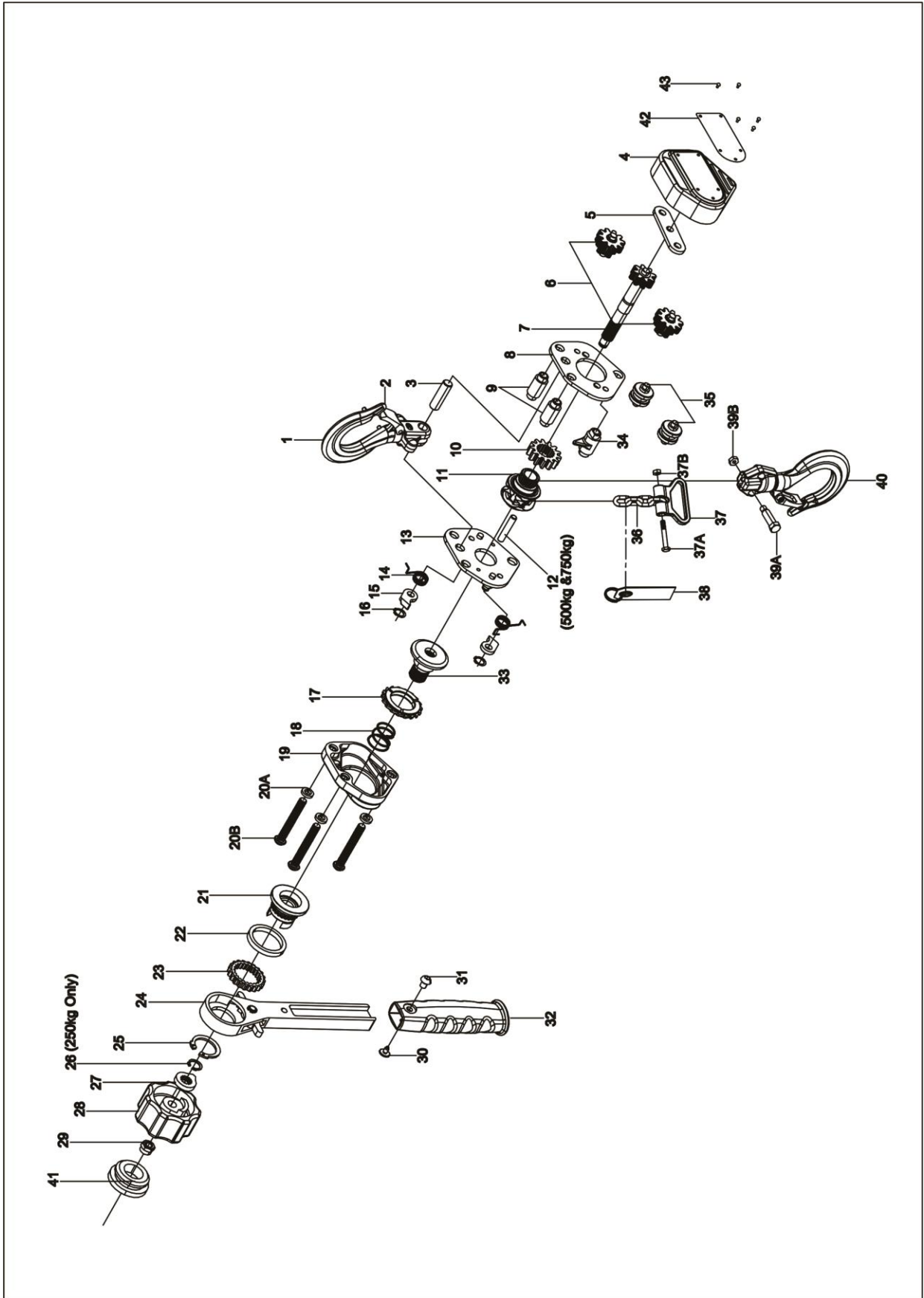

**ALHC Series Lever Operated Chain Hoist BOM**

Index No.	Description	Qty.	Part No.		
			1/4 ton	1/2 ton	3/4 ton
1	Top Hook Assembly	1	ALHC0025-01	ALHC0050-01	ALHC0075-01
2	Casting Safety Latch Assembly	2	ALHC0025-02	ALHC0050-02	ALHC0075-02
3	Top Hook Shaft	1	ALHC0025-03	ALHC0050-03	ALHC0075-03
4	Gear Cover	1	ALHC0025-04	ALHC0050-04	ALHC0075-04
5	Reinforced Plate	1	ALHC0025-05	ALHC0050-05	ALHC0075-05
6	Spur Gear Assembly	2	ALHC0025-06	ALHC0050-06	ALHC0075-06
7	Drive Shaft	1	ALHC0025-07	ALHC0050-07	ALHC0075-07
8	Gear Side Plate Assembly	1	ALHC0025-08	ALHC0050-08	ALHC0075-08
9	Stay Bolt	2	ALHC0025-09	ALHC0050-09	ALHC0075-09
10	Load Gear	1	ALHC0025-10	ALHC0050-10	ALHC0075-10
11	Load Sheave	1	ALHC0025-11	ALHC0050-11	ALHC0075-11
12	Pin	1	N/A	ALHC0050-12	ALHC0075-12
13	Lever Side Plate Assembly	1	ALHC0025-13	ALHC0050-13	ALHC0075-13
14	Pawl Spring	2	ALHC0050-14		
15	Pawl	2	ALHC0050-15		
16	Snap Ring	2	ALHC0050-16		
17	Ratchet Disc	1	ALHC0025-17	ALHC0050-17	ALHC0075-17
18	Spring	1	ALHC0025-18	ALHC0050-18	ALHC0075-18
19	Brake Cover	1	ALHC0025-19	ALHC0050-19	ALHC0075-19
20A	Washer	3	ALHC0025-20A	ALHC0050-20A	ALHC0075-20A
20B	Socket Cap Screw	3	ALHC0025-20B	ALHC0050-20B	ALHC0075-20B
21	Brake Plate	1	ALHC0025-21	ALHC0050-21	ALHC0075-21
22	Bushing	1	ALHC0025-22	ALHC0050-22	ALHC0075-22
23	Change Over Gear	1	ALHC0025-23	ALHC0050-23	ALHC0075-23
24	Lever Handle Assembly	1	ALHC0025-24	ALHC0050-24	ALHC0075-24
25	Snap Ring	1	ALHC0025-25	ALHC0050-25	ALHC0075-25
26	Snap Ring	1	ALHC0025-26	N/A	
27	Stop Knob	1	ALHC0025-27	ALHC0050-27	ALHC0075-27
28	Hand Wheel	1	ALHC0025-28	ALHC0050-28	ALHC0075-28
29	Nut	1	ALHC0050-29		
30	Bolt	1	ALHC0050-30		
31	Nut	1	ALHC0025-30B	ALHC0050-30B	ALHC0075-30B
32	Rubber Grip	1	ALHC0025-31	ALHC0050-31	ALHC0075-31
33	Disc Hub	1	ALHC0025-33	ALHC0050-33	ALHC0075-33
34	Stripper	1	ALHC0025-34	ALHC0050-34	ALHC0075-34
35	Guide Roller	2	ALHC0025-35	ALHC0050-35	ALHC0075-35
36	Load Chain	As Req'd	Φ3.2×9	Φ4.3×12	Φ4.3×12
37	Chain Stop	1	ALHC0050-37		
37A	Socket Head Cap Screw	1	ALHC0050-37A		
37B	Lock Nut	1	ALHC0050-37B		
38	Warning tag	1	ALHC0050-38		
39A	Load Pin	1	ALHC0025-39A	ALHC0050-39A	ALHC0075-39A
39B	Lock Nut	1	ALHC0025-39B	ALHC0050-39B	ALHC0075-39B
40	Bottom Hook Assembly	1	ALHC0025-40	ALHC0050-40	ALHC0075-40
41	Hand Wheel Cover	1	ALHC0050-41	ALHC0050-41	ALHC0075-41
42	Name Plate	1	ALHC0025-42	ALHC0050-42	ALHC0075-42
43	Rivet	2	ALHC0050-43A		
		3	ALHC0050-43B		

Record your purchase and installation information here

Purchased from: \_\_\_\_\_

Date: \_\_\_\_\_

Serial Number: \_\_\_\_\_

Model Number: \_\_\_\_\_

Stock Number: \_\_\_\_\_

Location Installed: \_\_\_\_\_

Date Installed: \_\_\_\_\_

Date in Service: \_\_\_\_\_

**Strength - Safety - Reliability**

Atlas Lifting & Rigging, LLC

WWW.ALRLIFT.COM  
1-833-ALR-LIFT