

WARRANTY INFORMATION AND TECHNICAL SERVICE

ALR warrants every product it sells against manufacturers' defects. If one of our tools needs service or repair, please contact Technical Service by calling 1-833-ALR-LIFT, 8AM to 5PM Anywhere in the US, Monday through Friday.

Warranty Period

The general warranty lasts for the time period specified in the literature included with your product or on the official ALR branded website.

- ALR products carry a limited warranty which varies in duration based upon the product. (See chart below)
- Accessories carry a limited warranty of one year from the date of receipt.
- Consumable items are defined as expendable parts or accessories expected to become inoperable within a reasonable amount of use and are covered by a 90 day limited warranty against manufacturer's defects.

Who is Covered

This warranty covers only the initial purchaser of the product from the date of delivery.

What is Covered

This warranty covers any defects in workmanship or materials subject to the limitations stated below. This warranty does not cover failures due directly or indirectly to misuse, abuse, negligence or accidents, normal wear-and-tear, improper repair, alterations or lack of maintenance.

Warranty Limitations

Please contact Technical Service at 1-833-ALR-LIFT for further clarification.

How to Get Technical Support

Please contact Technical Service by calling 1-833-ALR-LIFT. **Please note that you will be asked to provide proof of initial purchase when calling.** If a product requires further inspection, the Technical Service representative will explain and assist with any additional action needed. ALR has Authorized Service Centers located throughout the United States. For the name of an Authorized Service Center in your area call 1-833-ALR-LIFT or use the Service Center Locator on the ALR website.

More Information

ALR is constantly adding new products. For complete, up-to-date product information, check with your local distributor or visit the ALR website.

How State Law Applies

This warranty gives you specific legal rights, subject to applicable state law.

Limitations on This Warranty

ALR LIMITS ALL IMPLIED WARRANTIES TO THE PERIOD OF THE LIMITED WARRANTY FOR EACH PRODUCT. EXCEPT AS STATED HEREIN, ANY IMPLIED WARRANTIES OF MERCHANTABILITY AND FITNESS FOR A PARTICULAR PURPOSE ARE EXCLUDED. SOME STATES DO NOT ALLOW LIMITATIONS ON HOW LONG AN IMPLIED WARRANTY LASTS, SO THE ABOVE LIMITATION MAY NOT APPLY TO YOU.

ALR SHALL IN NO EVENT BE LIABLE FOR DEATH, INJURIES TO PERSONS OR PROPERTY, OR FOR INCIDENTAL, CONTINGENT, SPECIAL, OR CONSEQUENTIAL DAMAGES ARISING FROM THE USE OF OUR PRODUCTS. SOME STATES DO NOT ALLOW THE EXCLUSION OR LIMITATION OF INCIDENTAL OR CONSEQUENTIAL DAMAGES, SO THE ABOVE LIMITATION OR EXCLUSION MAY NOT APPLY TO YOU.

ALR sells through distributors only. The specifications listed in ALR printed materials and on official ALR website are given as general information and are not binding. ALR reserves the right to effect at any time, without prior notice, those alterations to parts, fittings, and accessory equipment which they may deem necessary for any reason whatsoever.

Product Listing with Warranty Period

90 Days – Parts; Consumable items
1 Year – Motors; Machine Accessories
2 Years – Electric Hoists, Electric Hoist Accessories

Table of Contents

Section	Page
1. Warning!!!	5
Introduction.....	6
Description.....	6
2. Specification.....	7
3. Unpacking.....	10
Contents of the Shipping Container.....	10
Installation.....	10
Electrical Instructions.....	10
Installing Chain Container.....	11
4. Pre-Operation Inspection.....	12
Inspecting the Load Chain.....	12
Inspecting the Hooks.....	12
5. Operating the Hoist.....	12
6. Adjustments.....	13
Safety Clutch Adjustment.....	13
Replacing Load Chain.....	14
Brake Adjustment.....	15
Inspection Schedule A.....	16
Inspection Schedule B.....	16
7. Inspection Procedures: Allowable Limits.....	17
Load Chain.....	17
Hooks (Top and Bottom).....	17
Brake Friction Pad.....	17
8. Troubleshooting.....	18
9. Stock Number.....	19
10. Replacement Parts.....	19
11. Manual Electric Chain Hoist Parts.....	19

1. Warning!!!

- 1 Read and understand the entire owner's manual before attempting assembly or operation.
- 1 Read and understand the warnings posted on the machine and in this manual. Failure to comply with all of these warnings may cause serious injury.
- 2 Replace the warning labels if they become obscured or removed.
- 3 Do not use this chain hoist for other than its intended use. If used for other purposes, ALR disclaims any real or implied warranty and holds itself harmless from any injury that may result from that use.
- 4 This chain hoist is designed and intended for use by properly trained and experienced personnel only. If you are not familiar with the proper and safe operation of a chain hoist, do not use until proper training and knowledge have been obtained.
- 5 Do not install this chain hoist where explosive hazards may exist.
- 6 Give your work undivided attention. Looking around, carrying on a conversation and "horse-play" are careless acts that can result in serious injury.
- 7 Do not use to lift people, or loads over people. Warn others in the vicinity when lifting or transporting a load. Avoid swinging load and hook.
- 8 Do not exceed the rated capacity of the chain hoist.
- 9 Make sure limit switches are operating properly. Do not use limit switches as routine operating stops; they are emergency devices only.
- 10 Do not use the load chain as a sling; this may cause damage to the chain.
- 11 Maintain firm footing when operating the hoist.
- 12 Always inspect the chain hoist for damage prior to use. Do not use a chain hoist with twisted, kinked, worn or otherwise damaged chain. If the chain hoist is damaged, do not use until it has been repaired or replaced.
- 13 Do not use more than one chain hoist to lift or move a load. If this is unavoidable, *each* chain hoist must have the same capacity as the load to be moved.
- 14 Never allow the load chain to "set" over sharp edges. All lifts must be made with straight chain that is free of obstacles.
- 15 Do not use a chain hoist unless load is centered between top and bottom hooks.
- 16 Protect load chain from weld splatter and other contaminants. Do not allow the hook or chain to be contacted by a live welding electrode.
- 17 Always take time to study the job to be performed and choose the safest method. Do not place yourself or other people in an unsafe position.
- 18 Leave all internal maintenance to a qualified Atlas Lifting & Rigging service center.
- 19 Replace the chain with factory replacement chain only. Do not use any other type of chain.
- 20 Never use the chain hoist if either hook is stretched, deformed, or has a broken or missing safety latch. Always replace the safety latch and/or the hook before placing the chain hoist back into service.
- 21 Do not operate this hoist while tired or under the influence of drugs, alcohol or any medication.
- 22 Understand and follow all procedures as set forth in American National Standards titled "Performance Standard for Electric Chain Hoists." ANSI/ASME HST-1. This standard is available through the American Society of Mechanical Engineers, www.asme.org.

Familiarize yourself with the following safety notices used in this manual:



This means that if precautions are not heeded, it may result in minor injury and/or possible machine damage.



This means that if precautions are not heeded, it may result in serious injury or possibly even death.

Introduction

This manual is provided by ALR covering the safe operation and maintenance procedures for a ALR Electric Chain Hoist. This manual contains instructions on installation, safety precautions, general operating procedures, maintenance instructions and parts breakdown. This machine has been designed and constructed to provide consistent, long-term operation if used in accordance with instructions set forth in this manual. If there are any questions or comments, please contact either your local supplier or ALR.

Description

ALR electric chain hoist models TEH-1 is available in a variety of voltages and lifting and traversing configurations.

- Model TEH-1 features single lift speed, 115V (Prewired) 60Hz single-phase power requirement.

- Model TEH-3 features single lift speed, three-phase power requirement.

500kg to 2t: 460V(Prewired)/230V

3t: 460V

The Titon series electric chain hoists comply with ANSI/ASME B30.16 and HST-1 standards.

All chain hoists are available in custom configurations to meet your specifications. Contact your dealer or ALR for more information.

Record your purchase information here for quick reference:

Product No.:	Serial No.:
Purchased From:	Date Purchased:

2. Specification

0.5t & 1t

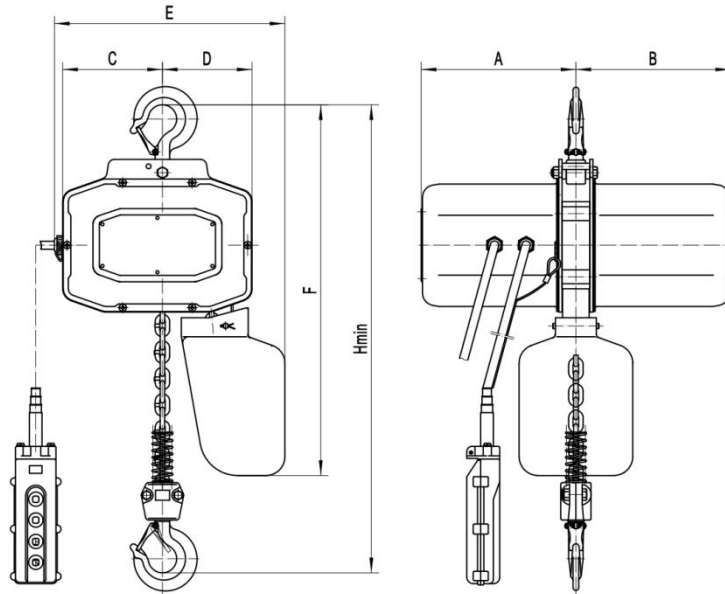

2t & 3t

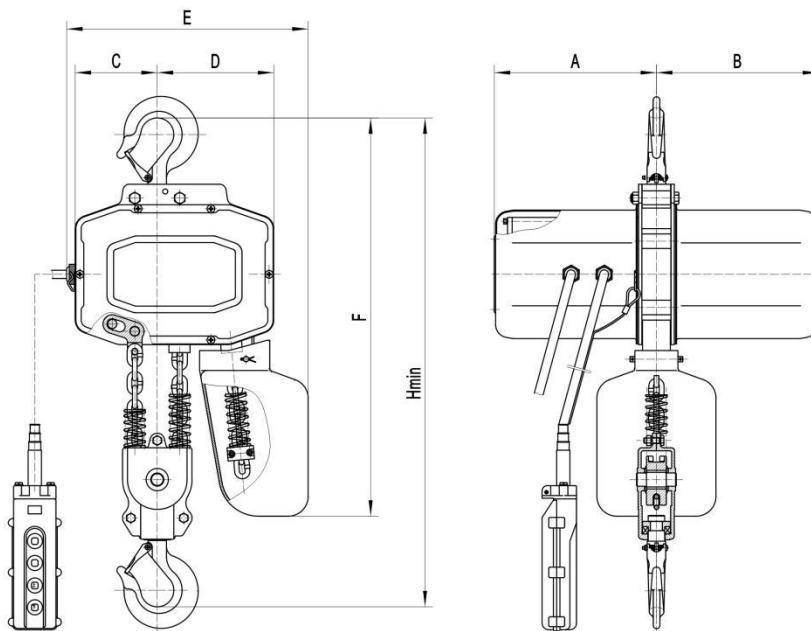

TITON ELECTRIC CHAIN HOIST SPECIFICATION & DIMENSIONS (1-Phase Dual Voltage)

Product Number **TEH-1-005-10** **TEH-1-005-20** **TEH-1-005-30** **TEH-1-010-10** **TEH-1-010-20** **TEH-1-010-30** **TEH-1-020-10** **TEH-1-020-20** **TEH-1-020-30**

Capacity **(ton)** **0.5** **0.5** **0.5** **1** **1** **1** **2** **2** **2**

Load Chain Fall			1	1	1	1	1	1	1	2	2	2
Capacity	(lbs)		1100	1100	1100	2200	2200	2200	2200	4400	4400	4400
Capacity Test Load	(lbs)		1375	1375	1375	2750	2750	2750	2750	5500	5500	5500
Capacity Test Load	(ton)		0.625	0.625	0.625	1.25	1.25	1.25	1.25	2.5	2.5	2.5
Lifting Speed	ft/min		23	23	23	19.7	19.7	19.7	19.7	9.8	9.8	9.8
Motor Power	hp		1.6									
Power Supply			1-Phase 115v/230v 60Hz									
Control Voltage	V		24									
Insulation Class			F									
Duty Rating			H3 / 25%									
Load Chain Dimensions	(mm)		Φ7.1 x 21									
Standard Lift	(ft)		10	20	30	10	20	30	10	20	30	
Cable Length	(ft)		8.2									
Height	h	(in)	16.5	16.5	16.5	16.5	16.5	16.5	16.5	16.5	16.5	16.5
Length	a	(in)	22.6	22.6	22.6	22.6	22.6	22.6	22.6	22.6	22.6	22.6
Width	b	(in)	18.9	18.9	18.9	18.9	18.9	18.9	18.9	18.9	18.9	18.9
Net Weight	(lbs)		126.2	134.0	141.8	126.2	134.0	141.8	140.7	157.2	173.7	
Gross Weight	(lbs)		154.2	162.0	169.8	154.2	162.0	169.8	168.7	185.2		
Extra weight per foot of extra lift	(lbs)		0.8	0.8	0.8	0.8	0.8	0.8	0.8	1.7	1.7	1.7
Minimum headroom Hmin	H	(in)	20.5	20.5	20.5	20.5	20.5	20.5	20.5	24.8	24.8	24.8
Dimensions	A	(in)	9.6	9.6	9.6	9.6	9.6	9.6	9.6	9.6	9.6	9.6
	B	(in)	9.6	9.6	9.6	9.6	9.6	9.6	9.6	9.6	9.6	9.6
	C	(in)	6.2	6.2	6.2	6.2	6.2	6.2	6.2	4.9	4.9	4.9
	D	(in)	5.6	5.6	5.6	5.6	5.6	5.6	5.6	6.9	6.9	6.9
	E	(in)	13.8	13.8	13.8	13.8	13.8	13.8	13.8	13.8	13.8	13.8
	F	(in)	23.6	23.6	23.6	23.6	23.6	23.6	23.6	24.0	24.0	24.0

TITON ELECTRIC CHAIN HOIST SPECIFICATION & DIMENSIONS (3-Phase)

Product Number		TEH-3-005-10	TEH-3-005-20	TEH-3-010-10	TEH-3-010-20	TEH-3-020-10	TEH-3-020-20	TEH-3-030-10	TEH-3-030-20	
Capacity		(ton)	0.5	0.5	1	1	2	2	3	3
Load Chain Fall			1	1	1	1	2	2	2	2
Capacity	(lbs)		1100	1100	2200	2200	4400	4400	6600	6600
Capacity Test Load	(lbs)		1375	1375	2750	2750	5500	5500	8250	8250
Capacity Test Load	(ton)		0.625	0.625	1.25	1.25	2.5	2.5	3.75	3.75
Lifting Speed	ft/min		23	23	23	23	11.5	11.5	13.1	13.1
Motor Power	hp		1.1		2.1				4	
Power Supply			3-Phase 230v/460v 60Hz						3-Phase 230v 60Hz	
Control Voltage	v		24							
Insulation Class			F							
Duty Rating			H4 / 30%							
Load Chain Dimensions	(mm)		Φ7.1 x 21						Φ9 x 27	
Standard Lift	(ft)		10	20	10	20	10	20	10	20
Cable Length	(ft)		8.2							
Height	h	(in)	16.5	16.5	16.5	16.5	16.5	16.5	18.5	18.5
Length	a	(in)	22.6	22.6	22.6	22.6	22.6	22.6	24.8	24.8
Width	b	(in)	18.9	18.9	18.9	18.9	18.9	18.9	23.6	23.6
Net Weight	(lbs)		126.2	134.0	126.2	134.0	140.7	157.2	209.4	232.9
Gross Weight	(lbs)		154.2	162.0	154.2	162.0	168.7	185.2	242.5	265.9
Extra weight per foot of extra lift	(lbs)		0.7	0.7	0.7	0.7	1.7	1.7	2.4	2.4
Minimum headroom Hmin	H	(in)	20.5	20.5	20.5	20.5	24.8	24.8	31.5	31.5
Dimensions	A	(in)	9.6	9.6	9.6	9.6	9.6	9.6	10.4	10.4
	B	(in)	9.6	9.6	9.6	9.6	9.6	9.6	10.4	10.4
	C	(in)	6.2	6.2	6.2	6.2	4.9	4.9	5.0	5.0
	D	(in)	5.6	5.6	5.6	5.6	6.9	6.9	8.1	8.1
	E	(in)	13.8	13.8	13.8	13.8	13.8	13.8	15.5	15.5
	F	(in)	23.6	23.6	23.6	23.6	24.0	24.0	29.1	29.1

3. Unpacking

Open shipping container and check for shipping damage. Report any damage immediately to your distributor and shipping agent. Do not discard any shipping material until the Chain Hoist is installed and running properly.

Missing parts, if any, should be reported to your distributor. Read this owner's manual thoroughly for assembly, maintenance and safety instructions.

Contents of the Shipping Container

- 1 Electric Chain Hoist
- 1 Chain Container with Bracket and fasteners
- 1 Owner's Manual

Installation

Support for the hoist may be hook, clevis pin, trolley, or beam clamp. Whatever method of suspension is chosen, the support components **must** be rated equal to, or greater than the capacity of the chain hoist. Supporting structures (such as I-Beams, etc.) should be installed by properly licensed professional installers.

Electrical Instructions

⚠ WARNING Electrical connections must be made by a qualified electrician in compliance with all relevant codes. This machine must be properly grounded to help prevent electrical shock and possible fatal injury.

Grounding

In the event of a malfunction or breakdown, grounding provides a path of least resistance for electric current to reduce the risk of electric shock.

This machine's power cord must be fitted with an appropriate UL/CSA listed plug, or it can be "hard-wired" directly to a control panel. If hard-wired, make sure a disconnect is available for the operator.

If a plug is installed, it must have an equipment-grounding conductor and a grounding prong. The plug must be plugged into a matching outlet that is properly installed and grounded in accordance with all local codes and ordinances.

Do not modify the plug – if it will not fit the outlet, have the proper outlet installed by a qualified electrician.

Improper connection of the equipment-grounding conductor can result in a risk of electric shock. The conductor with insulation having an outer surface that is green with or without yellow stripes is the equipment-grounding connector.

If repair or replacement of the electric cord or plug is necessary, do not connect the equipment-grounding conductor to a live terminal.

Check with a qualified electrician or service personnel if the grounding instructions are not completely understood, or if in doubt as to whether the tool is properly grounded.

Repair or replace damaged or worn cord immediately.

Voltage Conversion

The **single phase model TEH-1** is designed for 115 volt or 230 volt operation. It is pre-wired for 115 volt. To switch voltage:

1. Disconnect hoist from power supply.
2. Remove the motor cover and move the plug from the 115V socket to the 230V socket.
3. Re-install the motor cover.

The **three phase model TEH-3** is designed for 230 volt or 460 volt operation. It is pre-wired for 460V. To change to 230V proceed for 0.5t to 2t as follows.

1. Disconnect hoist from power supply.
2. Remove the motor cover and move the plug from the 460V socket to the 230V socket.
3. Re-install the motor cover.

Refer to the diagrams at the back of this manual for any clarification of these procedures.

NOTE: When connecting plug to socket, check that the connector notch is fully engaged. To remove a plug, press on the notch tail to disengage notch.

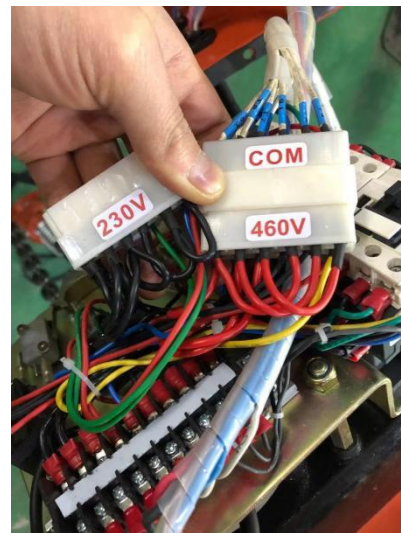

Figure 1
(three phase model shown)

Inspecting Hoist Motion

1. Before closing the circuit breaker and testing the hoist, check that wiring has been complete. If the hoist cannot be observed when the circuit breaker is closed, station an observer within sight of the hoist to report any movement when power is applied to the hoist. Be prepared to disconnect power if hoist motor starts when the power is applied. The hoist must remain motionless when power is applied. Find and correct any problems before continuing.
2. With no load on the load hook, press the UP button very briefly and observe hoist action. The hook should move upward.
3. If no motion occurs when the UP button is pressed and the hoist is connected to a three phase power supply, the power supply wires are incorrectly positioned. Switch any two of the three supply wires *at the power source*. **Do not attempt to rewire the hoist circuit or pendant controls for this problem.** Use the same safety precautions when reversing two of the supply wires as was used when the wires were originally connected.
4. Re-connect power and test hoist movement again without load. Run hoist to the complete lifting height to ensure limit switches are operating properly.

Installing Chain Container

Your hoist is supplied with a canvas chain container designed to fit the particular length of chain.

⚠WARNING Do not overfill chain container. If chain should overfill and begin to fall, the entire chain container may empty without warning, resulting in serious personal injury or property damage.

To assemble the chain container to the hoist:

1. Hang hoist in position on the I-Beam or trolley. Do not install chain container yet. Allow slack side and load side of chain to hang freely from hoist.
2. Apply power to the hoist and press the DOWN button until the lower limit switch is tripped.
3. Check the chain container to ensure that the seam is inside the bag. The bag must not be inside out.
4. Remove the screw and washer holding the end chain to the hoist (Figure 2). Mount the bracket of the chain container in that location.
5. Put the chain stop into the container, and operate the hoist to bring the load hook up until the upper limit switch is tripped.
6. Check the chain to ensure that all the non-loaded chain is completely in the container.

⚠CAUTION Do not put chain into the chain container by hand! By not following the above steps, the chain can become twisted or kinked and can damage the hoist.



Figure 2

4.Pre-Operation Inspection

Inspecting the Load Chain

Clean the chain with a solvent, and carefully inspect the entire load chain. Replace damaged chain before using the chain hoist. See “*Inspection*

Procedures: Allowable Limits” on page 17 for the maximum pitch allowed for chain length. If the chain exceeds this amount, it must be replaced.

Also replace the load chain if any of the following are identified:

1. Seriously rusted or cracked.
2. Marks on the chain surface are deeper than 5% of the link’s diameter.
3. Links are twisted or deformed.
4. The links are stretched too long or seriously worn on the surface, especially at the points where links contact each other.

Never extend load chain by welding a second piece to the original.

⚠WARNING Do not operate the hoist with a twisted, kinked or damaged load chain. Do not splice the load chain.

Check that the chain does not twist along its length from hoist to hook. If twist is present on units with multiple falls, the hook must be passed back through the chain loop to remove all twist in the chain.

⚠WARNING The load chain supplied with your ALR chain hoist is designed, manufactured, and tested for proper fit and durability. Over a period of time, the chain may need to be replaced. For your own safety, use factory replacement chain only. Use of other than factory replacement chain may cause serious injury and/or damage to the hoist.

A light coat of 30-weight oil applied periodically to the chain will create easier operation and prolong the life of the chain.

Inspecting the Hooks

It is important to check top and bottom hooks for proper opening and other signs of deformation or damage. Replace a hook immediately if any of the following problems are identified:

1. The safety latch no longer contacts the hook opening.
2. The vertical angle at the neck of the hook reaches 10° (see Figure 3).

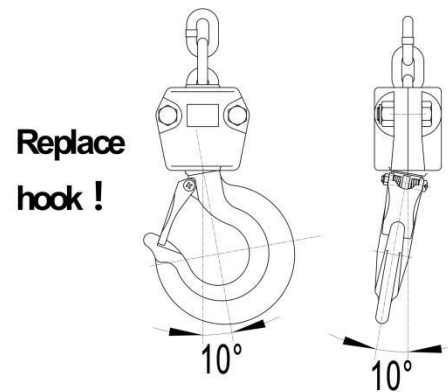

Figure 3

3. Chemical corrosion or cracks on the hook.
4. Excessive wear on the inside surface.
5. The throat opening has enlarged. (See page 17 for the maximum allowable limits for the throat opening.)

NOTE: Excessive hook throat opening or twist indicates abuse or overloading of the hoist. If such deformation is discovered, inspect hoist, chain and all supporting members very carefully for additional indications of excessive hoist loading.

⚠WARNING Do not attempt repair of a hook by heat treating, bending or attaching anything by welding. Such procedures will weaken and may cause failure of the hook.

5.Operating the Hoist

Allow the hoist to come to a full stop before changing direction. Rapidly reversing or catching a falling load can overload the hoist system and cause a failure in the hoist and/or chain, resulting in injury or property damage.

If the hoist is connected to a manual trolley, move the hoist by pushing on the suspended load. Move an unloaded hoist by pulling on the empty hook. Do **NOT** move the hoist by pulling on the pendant cord.

The brake mechanism must be kept clean and free from dirt, water, and oil. Never allow oil to penetrate the brake mechanism. Always keep your hoist clean, and store in a clean, dry location.

Follow this general procedure for hoisting loads:

1. Secure the upper hook to the supporting structure.
2. Place load sling or chain in the center of the bottom hook, making sure the safety latch is secure. **Never load the hook in front of the safety latch.** See Figure 4.

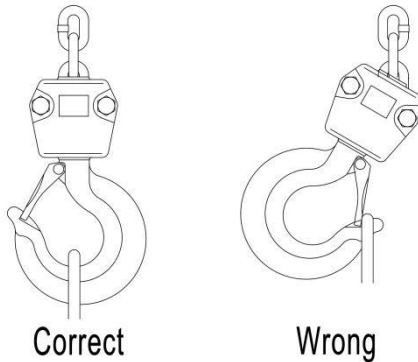

Figure 4

3. Avoid lifting one load with two hoists. If this is unavoidable, apply equal weight to both hoists and use hoists with the proper lift capacity. **Capacity of each hoist must be equal to the total load to be lifted.**
4. Press UP button and remove all slack in load chain. Increase tension in the load chain until the hoist is about to raise the load.
5. Check again that the load is properly slung, directly under hoist, and will not suddenly swing or twist.
6. Raise load an inch or two above the ground and stop. Observe load for a few moments, looking for signs that the load or hoist system is unstable, or other indications that there is a problem.
7. Check that the chain is not twisted at the bottom hook. All welds should face the same direction (see Figure 6). For hoists with two or more falls of chain, make sure the bottom hook is not turned over. This may cause the chain to twist.
8. Raise load to the traveling height. Raise only to the height necessary to safely clear all obstacles.
9. Lower load at destination. If both UP and DOWN commands must be used during lowering, pause for a moment between each reversal of load direction.

10. Slowly allow weight to shift from hoist to ground or new support. Do not approach load until all tension is out of chain and load is stable.

6.Adjustments

Safety Clutch Adjustment

The load limitation of the safety clutch has been set to within 1.25 to 1.6 times the rated load of the hoist. Generally, the safety clutch will not require adjustment. But if the hoist ever fails to lift the rated load while the rotor is turning, the safety clutch must be re-adjusted. Proceed as follows (see Figure 5):

1. Suspend the rated load in the bottom hook.
2. Push the UP button to create tension on the load chain, but do not raise the load off the ground.
3. Disconnect the power source, and remove the gear side cover.
4. Rotate the nut (A) clockwise .
5. Connect hoist to power source, and push the UP button on the pendant control. The hoist should now lift the rated load. If it will not lift the load, disconnect power and repeat steps 4 and 5 to tighten the adjusting circle nut until it can lift the rated load.
6. Now change the load to within 1.25 to 1.6 times the rated load, then push the UP button. The hoist should NOT be able to lift the load. If it can lift the load, repeat steps 4 and 5, rotate the adjusting nut (A) until the hoist cannot lift the load.
7. Unload the hoist and repeat step 6 with the original rated load. The hoist should now be able to lift the original rated load. If it does not, repeat steps 6 and 7 until the hoist operates with the rated load only, but not with the 1.25 to 1.6 times rated load.
8. Unload the hoist, and re-install the gear side cover.

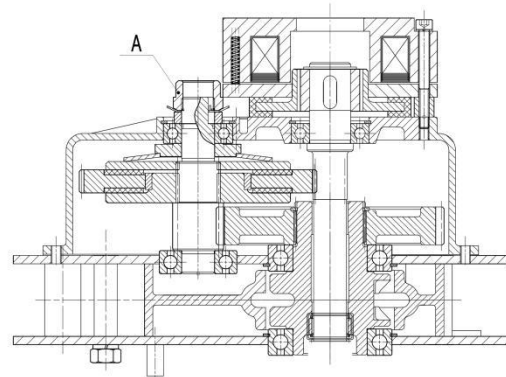

A- Adjusting nut

Figure 5

Replacing Load Chain

Over time, the load chain will wear or elongate. This can cause damage to the hoist, breakage, or non-engagement of the load sheave. The following procedures describe replacing the load chain for single and multiple fall hoists. **These procedures should be performed by experienced personnel only.**

How to Cut Chains

Use a bolt cutter with special cutter jaws for cutting hardened chain. Cut only one side of the link at a time. When making the second cut, place a mat over the chain to catch the flying chain section.

Making a C-Link

Replacing load chain will require the use of a C-link (in some cases, two C-links), which you can easily make as follows:

1. Cut a link from the old chain.
2. Cut the weld from the link leaving an opening approximately 1.25 times the diameter of the link material. See Figure 15.
3. Grind the cut areas smooth and remove all burrs.

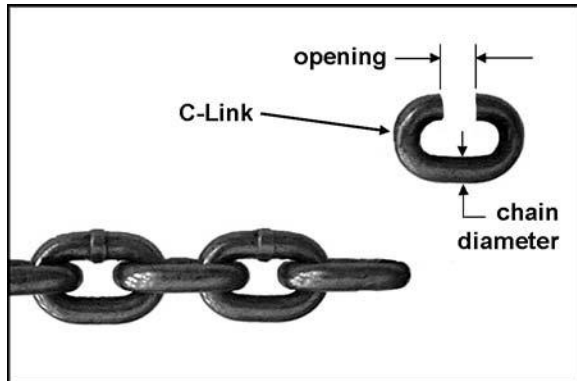

Figure 6

Single Fall Chain Hoist

1. Lower the load hook until only 1 to 2 feet of slack chain remains in the chain container.
2. Remove chain container.
3. On the slack side of the chain, remove the chain stop and the spring (Figure 7). Keep these handy for later re-installing.
4. Using a C-link, connect the new chain to the old chain. Be sure vertical link welds face away from load sprocket (see Figure 8).
5. Keep tension on both sides of the chain and lower the load hook to pull the new chain through the hoist. Do not let the chain twist or bind as it is being pulled through the hoist.

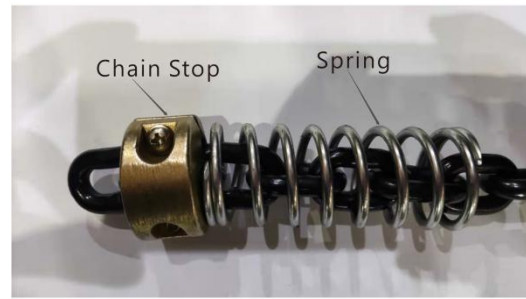

Figure 7

6. Stop hoist when 1 to 2 feet of new chain remains on the slack side.
7. Install the spring and chain stop on the slack end of the chain.
8. Remove the load hook and the spring from the old chain, and install them on the new chain. Inspect condition of both spring and hook.
9. Lower load hook until the limit switch stops hoist movement. Inspect the chain for any signs of twist.
10. Install chain container following the instructions in this manual. Do not fill chain container by hand.
11. It is recommended that after installing new chain, the first few lifts be limited to no more than 25-50% of the rated load. Thoroughly inspect chain for twist before placing hoist in routine service.

Vertical and Horizontal Links

Vertical and horizontal are determined by the relationship with the load sprocket. Vertical links will be guided by the center slit in the load sprocket. Horizontal links will engage in the oval pockets on the sprocket. See Figure 8.

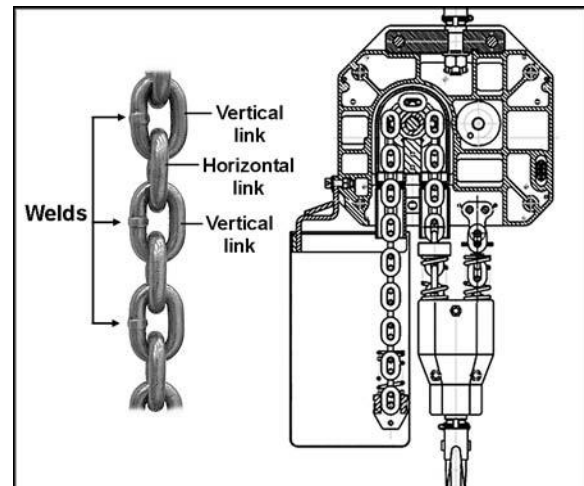

Figure 8

Dual/Multiple Fall Chain Hoists

CAUTION The link on the load side end must be a vertical link. If it is a horizontal link, the chain will have a twist in it.

1. Lower hook until only 1 to 2 feet of slack chain remains in the chain container.
2. Remove chain container.
3. On the slack side of the chain, remove the chain stop, and remove the black spring(s). (see Figure 7). Keep these handy for later re-installing.
4. Using a C-link(s), connect the new chain to the old chain. If the end link of the old chain is horizontal, use two C-links. If the end link of the old chain is vertical, use one C-link. See Figure 9. Using the correct number of C-links will properly orient the chain, and ensure that the first link on the load side end is a vertical link.
5. Install the spring(s) and chain stop on the opposite end of the new chain.
6. Support the load hook so that the load chain can pass through the chain sheaves smoothly. Figure 7 shows the load chain path for the various sizes of hoist.
7. Press the DOWN button to move the chain through the hoist. Keep tension on the chain as you pull it through to the load side, until the C-link(s) clears the hoist at the load side.
8. Place the first link of the new chain into the load side end holder. Be sure that there is no twisting of chain between last chain sprocket and load side end holder.
9. Remove the chain stop bolt from the old chain and install on the new chain. **Do not substitute any other bolt in this application.** Use a new cotter pin to secure bolt.
10. Install chain container following instructions in this manual. Do not fill chain container by hand.
11. Lower hook until limit switch stops hoist movement, then raise hook until limit switch stops hoist movement. Inspect chain for any signs of twist and correct before continuing.
12. It is recommended that the first few lifts be limited to no more than 25-50% of the rated load. Inspect chain for twist before placing hoist into routine service.

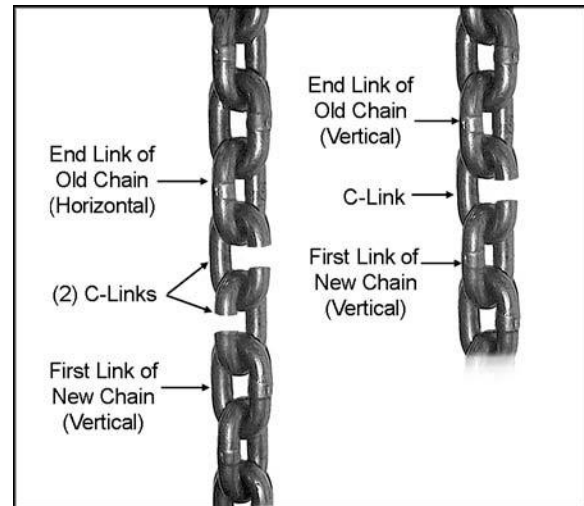

Figure 9

Brake Adjustment

The normal gap between the armature and the iron core is from 0.3mm to 0.4mm. If the gap is out of the range of 0.3mm to 0.4mm, it must be adjusted as follows (see Figure 10):

1. Disconnect hoist from power source.
2. Remove the gear side cover.
3. Insert a 0.4mm spacer between the iron core.
4. Tighten the three nuts by an equal amount one by one. The gap is now adjusted to 0.4mm.
5. Release the three nuts by 1/6 of a turn and remove the spacer. Re-tighten each of the nuts by 1/6 of a turn.
6. Re-install gear side cover.

NOTE: When adjusting the brake, if the brake pad is found deformed, the glue has failed, or the lining is severely worn, the brake pad should be replaced. See page 17.

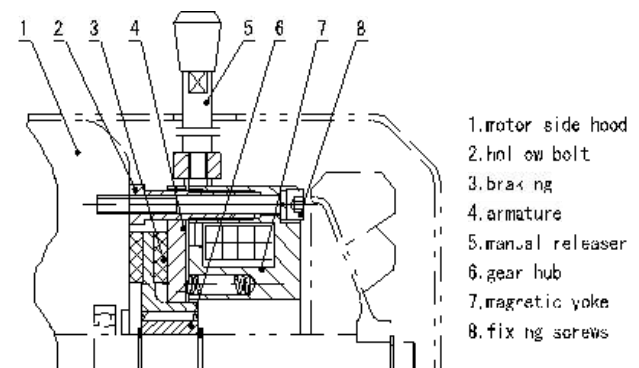

Figure 10

7. Inspection and Maintenance

⚠WARNING All repairs and adjustments are to be performed by trained and experienced personnel using procedures that are approved for the hoist system being serviced. All safety-related deficiencies discovered in the inspection are to be corrected before hoist is placed back in service. Check for internal damage whenever external damage has occurred.

Read and follow the ANSI Inspection and Maintenance instructions. Know the meaning of Frequent Inspection, Periodic Inspection, Normal Service, Heavy Service, and Severe Service. It is the customer's responsibility to understand and follow all ANSI and ALR inspection and maintenance instructions.

The following items are to be inspected by appointed personnel at the time interval noted below. Dated inspection and repair reports must be maintained. Copies of all reports must be available to service personnel.

Inspection Schedule A

Service Interval:

- Normal Service – Monthly**
- Heavy Service – Weekly to Monthly**
- Severe Service – Daily to Weekly**

1. Check brake for slippage.
2. Check that push button controls operate properly.
3. Check that limit switches function properly. Without load, operate up button control while observing stopper spring. If stopper spring becomes compressed and motor does not stop, STOP operation immediately. Limit switch is not operating properly. Repeat test with down button control.
4. Check top hook and load hook for deformation, chemical damage, and cracks.
5. Check that load chain is clean and lightly lubricated, free of excessive wear or deformation at the contact points between links and link and hook. This hoist uses special alloy hoisting chain and does not interchange with any other manufacturer. All replacement chain must be purchased from your ALR distributor or from ALR directly by calling 1-833-ALR-LIFT.
6. Check that the chain passes through all sprockets smoothly while under load.
7. Check entire hoist system for signs of damage and loss of integrity.

Inspection Schedule B

Service Interval:

- Normal Service – Yearly**
- Heavy Service – Semi-Annually**
- Severe Service – Quarterly**

1. Perform all of the Schedule A items.
2. Check entire unit for loose screws, bolts, nuts and pins.
3. Check for evidence of excessive wear, corrosion, cracks, or distortion in the following parts: hook parts, chain attachments, suspension bolts and shafts, gears, bearings, pins, rollers, and locking and clamping devices.
4. Check for evidence of damage to hook parts including hook retaining nuts and collars and pins and hook holding frame and parts used to secure the frame.
5. Check for evidence of damage or excessive wear of load gear, sheave and sprocket wheel. If the pockets are too deep, the chain may jam with corresponding failure of engagement between chain and sprocket or sheave.
6. Check for evidence of excessive load brake wear. Inspect clearance between brake components, and adjust if needed.
7. Check for evidence of pitting or other deterioration of visible controller contacts.
8. Check for evidence of deterioration of supporting structures and trolleys.
9. Check for visible deformation of limit switch coil springs.
10. Check that all warning labels are present and readable.

Inspection Procedures: Allowable Limits Load Chain

Carefully inspect the entire load chain. Measure five consecutive links with calipers in the manner shown in Figure 11. Check every three feet and especially where excessive wear is indicated. Any load chain that shows noticeable deformation or heat influence must be replaced with a new one. Never extend load chain by welding a second piece to the original.

Capacity	Load Chain	9 Links Normal	9 Links Limit
1/2 ton	7.1x21mm	7.44"	7.66"
1 ton	7.1x21mm	7.44"	7.66"
2 ton	7.1x21mm	7.44"	7.66"

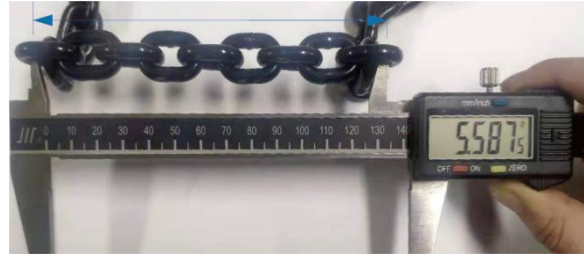

Figure 11

Hooks (Top and Bottom)

Replace the hook when the "A" or "B" measurement, as shown in Figure 12, reaches the limit shown in the tables below. Never heat treat the hook or attach anything to the hook by welding.

NOTE: Excessive hook throat opening or twist indicates abuse or overloading of the hoist. If such deformation is discovered, inspect the hoist, chain and all supporting members very carefully for additional indications of excessive hoist loading.

Throat – "A"

Capacity	A – Normal	A – Limit
1/2 ton	1.52"	1.67"
1 ton	1.52"	1.67"
2 ton	1.69"	1.86"

Seat – "B"

Capacity	B – Normal	B – Limit
1/2 ton	1.1"	under 0.99"
1 ton	1.1"	under 0.99"
2 ton	1.23"	under 1.11"

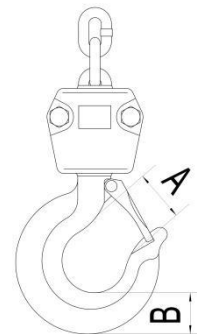

Figure 12

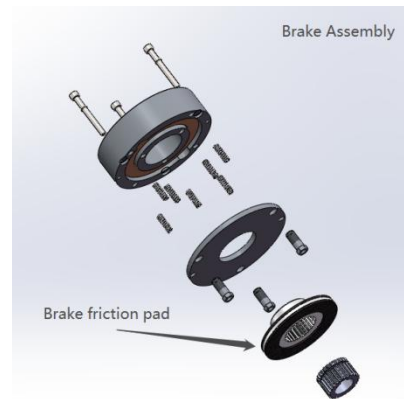

Figure 13

Brake Friction Pad

See Figure 13.

Before suspecting or replacing the brake friction pad, make sure the brake and the safety clutch have both been adjusted properly according to the instructions on pages 13 and 15.

If the friction pad is suspect, measure its thickness using a calipers. If it is under the thickness limit, replace it according to the chart below.

Capacity	Thickness Normal	Thickness Limit (replace)
0.5 ton	0.51"	under 0.47"
1 ton		
2 ton		

⚠ WARNING Do not attempt to rebuild a worn friction pad and do not modify brake system in order to use a worn-out pad.

8.Troubleshooting

Trouble	Probable Cause	Remedy
Motor will not run.	No incoming power, or low voltage.	Check hoist connections to power source. If low voltage, have certified electrician check incoming power.
	Fuse blown or circuit breaker tripped.	Replace fuse/re-set circuit breaker.
	Rectifier damaged in the phase protector so that the brake won't work.	Replace phase protector.
	Transformer damaged.	Replace transformer.
	Motor damaged.	Have motor replaced by a qualified service technician.
Hoist lifts but will not lower.	Broken conductor in pendant cord.	Test continuity of each conductor. Replace cable if needed.
	Up/down switch malfunctioning.	Repair or replace switch.
Hoist lowers but will not lift.	Overloaded.	Reduce load to within hoist capacity.
	Up/down switch malfunctioning.	Repair or replace switch.
	Clutch malfunction.	Have clutch replaced by qualified personnel.
Load continues drifting down excessively when hoist is stopped.	Grease or oil on the lining.	Open the hoist, disassemble the brake and clean the lining.
	Disc brake is worn.	Adjust clearance between armature and iron core. See page 15.
	Brake springs are damaged.	Replace brake springs.
Hoist moves in wrong direction.	Two of the three power supply wires are switched.	Switch any two of the three supply wires (see page 11).
Motor overheats.	Excessive load or too frequent use.	Operate within rated load and according to duty cycle rating.
	Brake drags.	Adjust brake clearance (see page 15).
Poor engagement of chain with sprocket/sheave.	Load chain severely worn.	Replace load chain. See pages 13 and 15.
	Sprocket wheel, sheave or the chain guide is severely worn.	Replace parts as needed.
Will not lift rated load.	Overload limit clutch friction torque too low.	Readjust the overload clutch to proper limits (qualified personnel only).
	Overload limit clutch damaged.	Replace overload limit clutch.
Limit switch failure.	Bad connection of limit switch leads.	Inspect the contacts of the leads and limit switches.
	Limit switch damaged.	Replace limit switch.

9. Stock Number

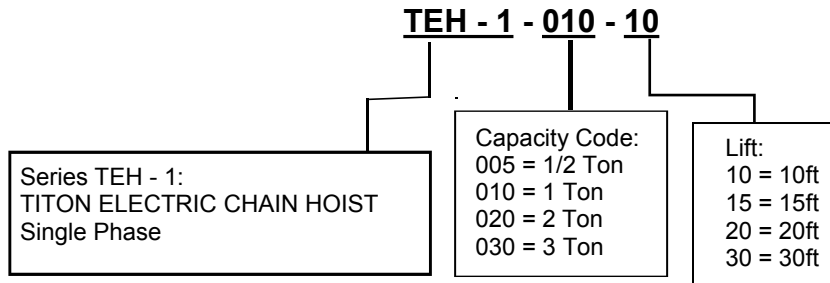

10. Replacement Parts

When ordering Parts, please provide the Hoist model number, and serial number located on the hoist name plate (see Figure 14 below).

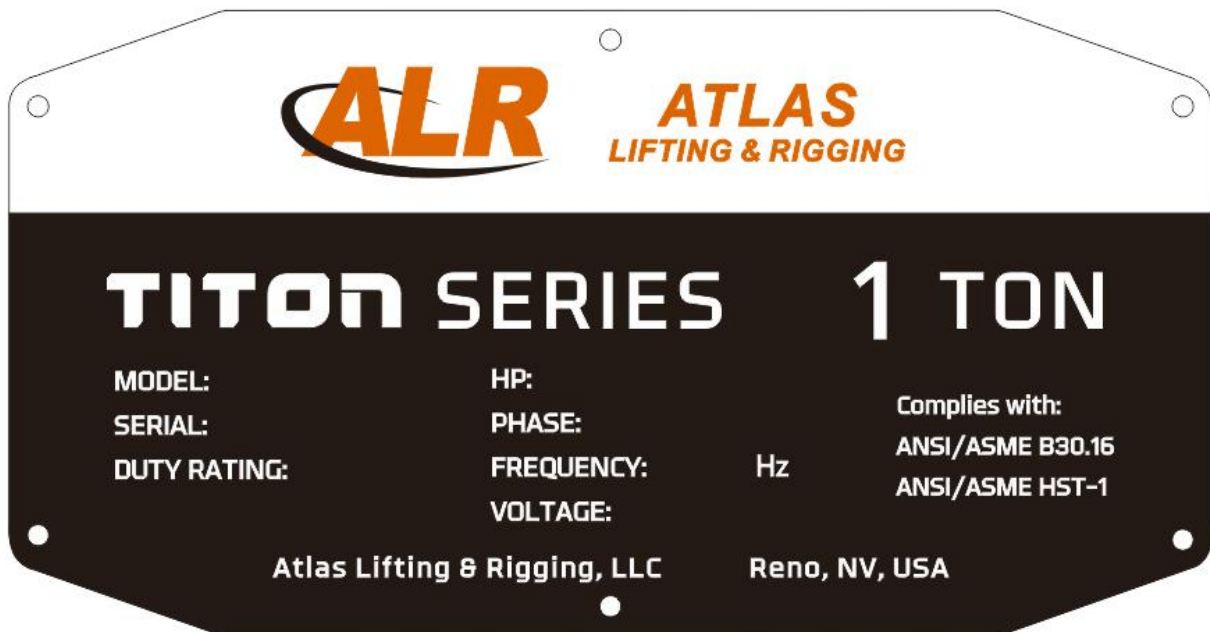
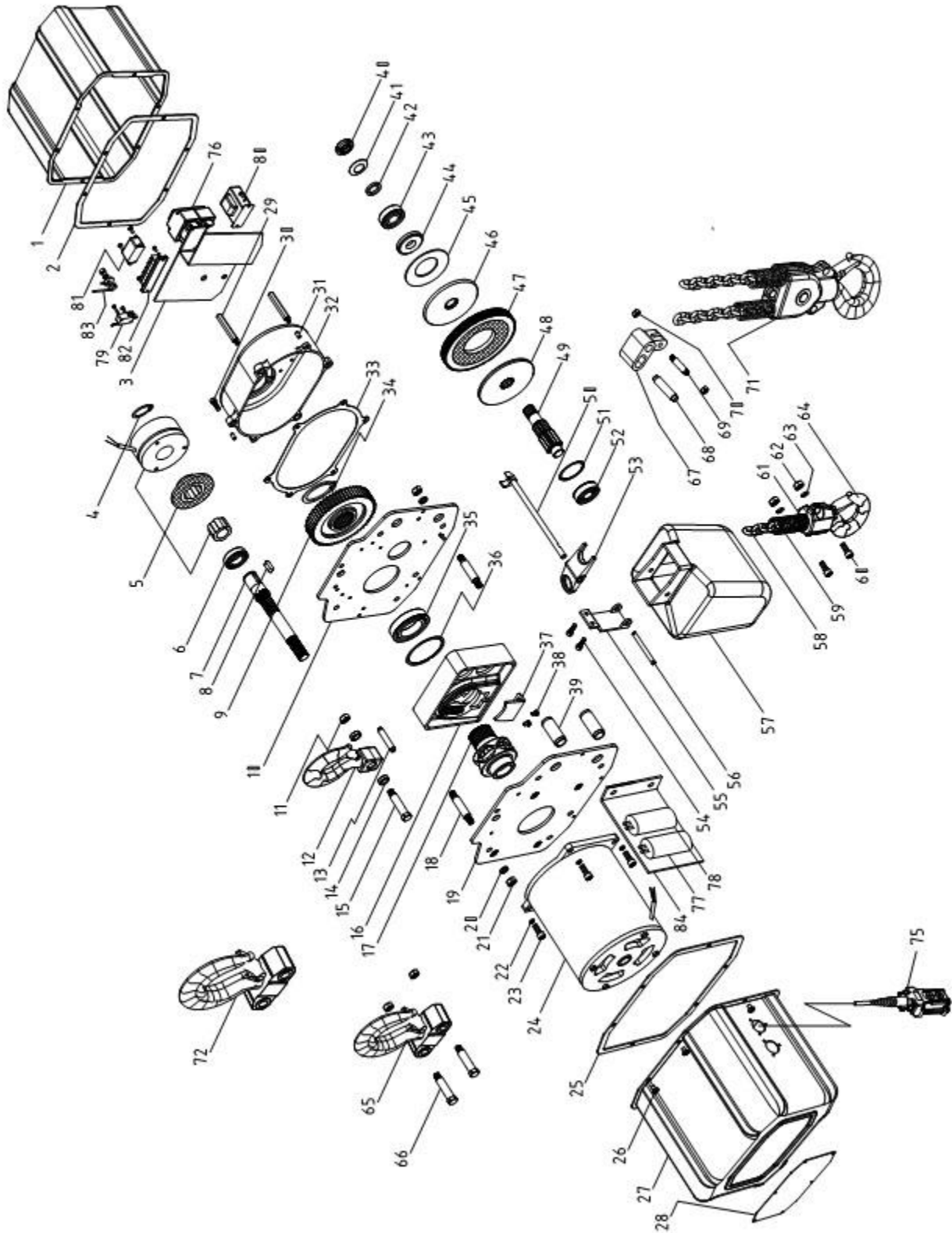

Figure 14 TITON Name Plate

11. Manual Electric Chain Hoist Parts

Replacement parts are listed on the following pages. To order parts or reach our service department, call 1-833- ALR-LIFT, Monday through Friday (see our website for business hours, www.ALRLIFT.com). Having the Model Number and Serial Number of your machine available when you call will allow us to serve you quickly and accurately.

TITON Electric Chain Hoist Parts Breakdown (1-Phase Dual Voltage)



Parts List: TITON Manual Electric Chain Hoist (1-Phase Dual Voltage)

No.	Description	Qty	No.	Description	Qty
1	Cover A	1	43	Rolling bearing 6004Z	1
2	Motor cover packing	1	44	Spring set	1
3	Electric board A	1	45	Spring	1
4	Axle race 25	1	46	Friction disk pressing panel	1
5	Brake assembly	1	47	Big Gear A	1
6	Rolling bearing 6005Z	1	48	Limit device base	1
7	Pinion gear A	1	49	Pinion gear B	1
8	Flat key 8×7×20	1	50	Limiter rotating axle	1
9	Big gear B	1	51	Stop ring 47	1
10	Right side plate	1	52	Rolling bearing 6204ZN	1
11	Hex nut M10	10	53	Limiter baffle	1
12	Top hook	1	54	Screw M6×16	2
13	Hook holder stop lever	1	55	Chain container hanging plate	1
14	Hook axle washer	2	56	Connecting pole	1
15	Hook axle	1	57	Chain container	1
16	Chain container	1	58	Load chainφ7.1×21	1
17	Chain sprocket	1	59	Limit spring	2
18	Staying pole	4	60	Hex bolt M8×30	2
19	Left side plate	1	61	Bottom hook assembly	2
20	Spring washer 10	8	62	Hex nut M8	2
21	Hex nut M10	8	63	Spring washer 8	2
22	Spring washer 8	4	64	Bottom hook	1
23	Hex screw M8×20	4	65	Top hook assembly(2t)	1
24	Motor assembly	1	66	Hook axle (2t)	2
25	Motor cover packing	1	67	Chain suspension holder (2t)	1
26	Screw M6×8	12	68	Connecting pin(2t)	1
27	Cover B	1	69	Pin (2t)	1
28	Name plate	2	70	Hex nut M8(2t)	2
29	Rivet screw	2	71	Bottom hook assembly (2t)	1
30	Hex screw M6×20	4	72	Top hook assembly(3t)	1
31	Spring locating pin 6×16	2	73	Top pulley assembly (3t)	1
32	Gear case	1	74	Bottom hook assembly (3t)	1
33	Gear case space	1	75	Push button	1
34	Axle race 42	1	76	contactor	3
35	Rolling bearing 6009ZN	1	77	Run capacitor (80μF)	1
36	Stop ring 75	1	78	Start capacitor (600μF)	1
37	Load chain baffle	1	79	Limit switch	2
38	Screw M6×10	2	80	Transformer	1
39	Conduit	2	81	Rectifier	1
40	Nut M20×1.5	1	82	Amphenol connector	1
41	Stop washer 20	1	83	Torsional spring	1
42	Nut washer	1	84	Electric board B	1

ELECTRICAL DRAWING (1-Phase Dual Voltage)

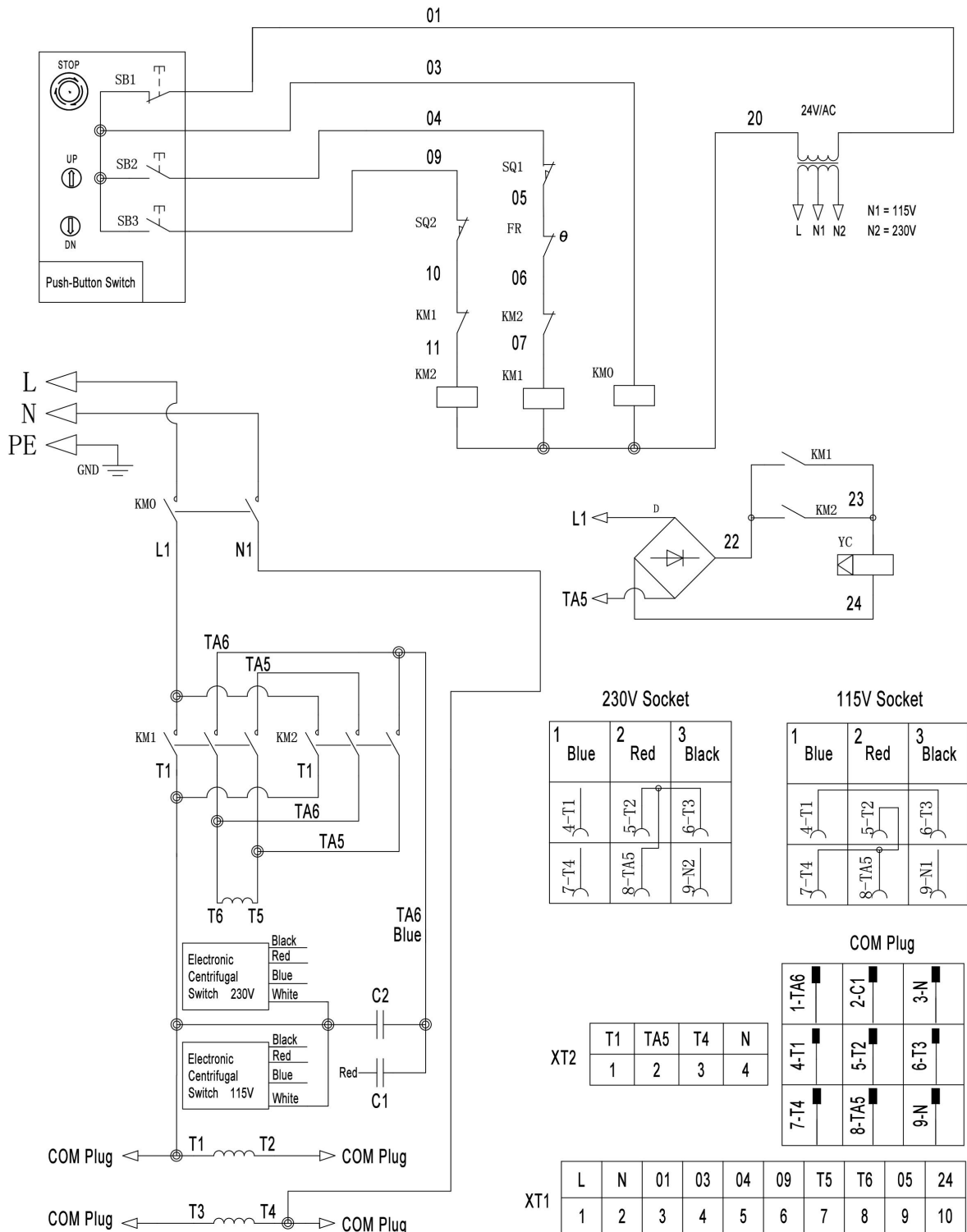

TITON Electric Chain Hoist Parts Breakdown (3-Phase Dual Voltage) 0.5t to 2t

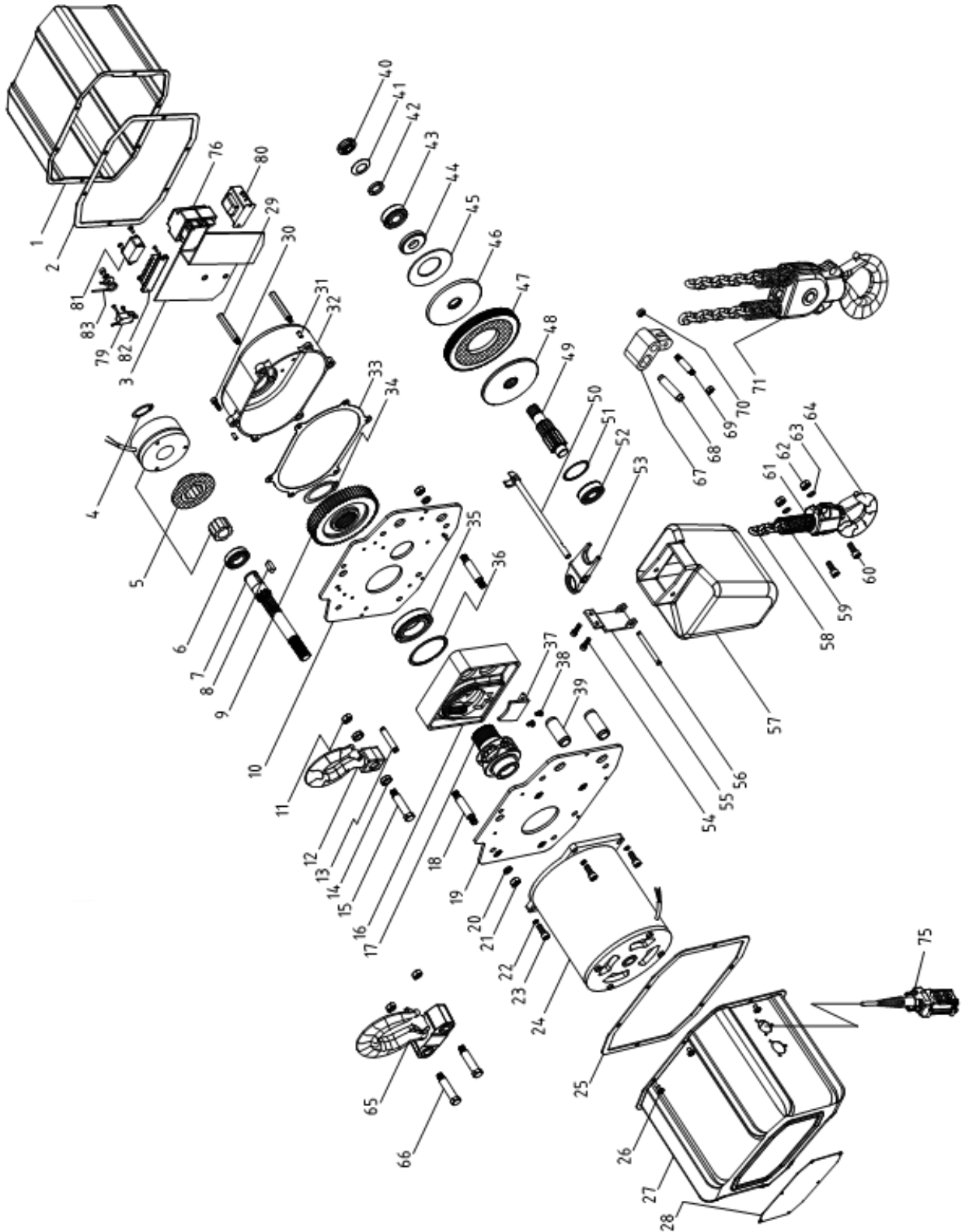

Parts List: TITON Manual Electric Chain Hoist (3-Phase Dual Voltage) 0.5t to 2t

No.	Description	Qty	No.	Description	Qty
1	Cover A	1	43	Rolling bearing 6004Z	1
2	Motor cover packing	1	44	Spring set	1
3	Electric board	1	45	Spring	1
4	Axle race 25	1	46	Friction disk pressing panel	1
5	Brake assembly	1	47	Big gear A	1
6	Rolling bearing 6005Z	1	48	Limit device base	1
7	Pinion gear A	1	49	Pinion gear B	1
8	Flat key 8×7×20	1	50	Limiter rotating axle	1
9	Big gear B	1	51	Stop ring 47	1
10	Right side plate	1	52	Rolling bearing 6204ZN	1
11	Hex nut M10	10	53	Limiter baffle	1
12	Top hook	1	54	Screw M6×16	2
13	Hook holder stop lever	1	55	Chain container hanging plate	1
14	Hook axle washer	2	56	Connecting pole	1
15	Hook axle	1	57	Chain container	1
16	Chain container	1	58	Load chainφ7.1×21	1
17	Chain sprocket	1	59	Limit spring	2
18	Staying pole	4	60	Hex bolt M8×30	2
19	Left side plate	1	61	Bottom hook assembly	2
20	Spring washer 10	8	62	Hex nut M8	2
21	Hex nut M10	8	63	Spring washer 8	2
22	Spring washer 8	4	64	Bottom hook	1
23	Hex screw M8×20	4	65	Top hook assembly(2t)	1
24	Motor assembly	1	66	Hook axle (2t)	2
25	Motor cover packing	1	67	Chain suspension holder (2t)	1
26	Screw M6×8	12	68	Connecting pin(2t)	1
27	Cover B	1	69	Pin (2t)	1
28	Name plate	2	70	Hex nut M8(2t)	2
29	Rivet screw	2	71	Bottom hook assembly (2t)	1
30	Hex screw M6×20	4	72	Top hook assembly(3t)	1
31	Spring locating pin 6×16	2	73	Top pulley assembly (3t)	1
32	Gear case	1	74	Bottom hook assembly (3t)	1
33	Gear case space	1	75	Push button	1
34	Axle race 42	1	76	contactor	3
35	Rolling bearing 6009ZN	1	77	Top hook assembly(5t)	1
36	Stop ring 75	1	78	Bottom hook assembly (5t)	1
37	Load chain baffle	1	79	Limit switch	2
38	Screw M6×10	2	80	Transformer	1
39	Conduit	2	81	Rectifier	1
40	Nut M20×1.5	1	82	Amphenol connector	1
41	Stop washer 20	1	83	Torsional spring	1
42	Nut washer	1			

ELECTRICAL DRAWING (3-Phase Dual Voltage) 0.5t to 2t

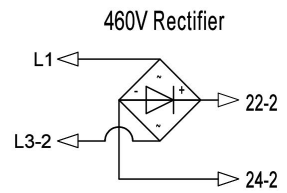
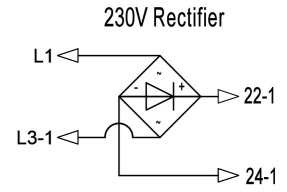
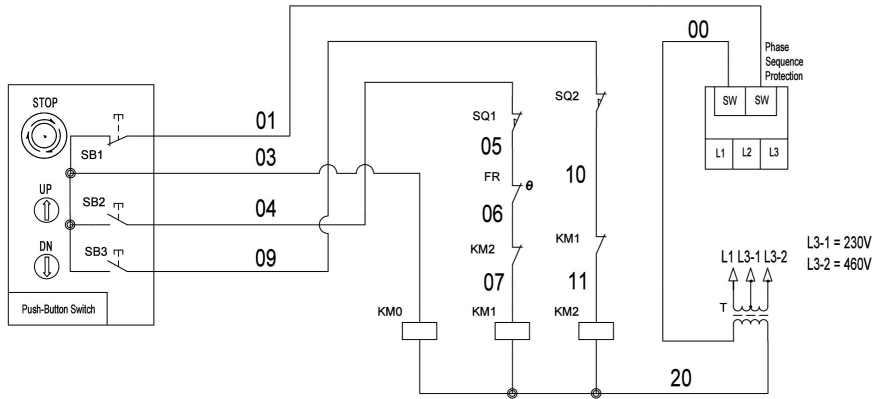

XT1	L1	L2	L3	01	03	04	09	05	06	24
	1	2	3	4	5	6	7	8	9	10

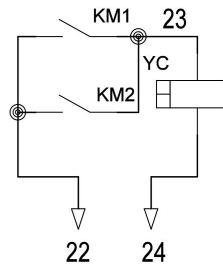
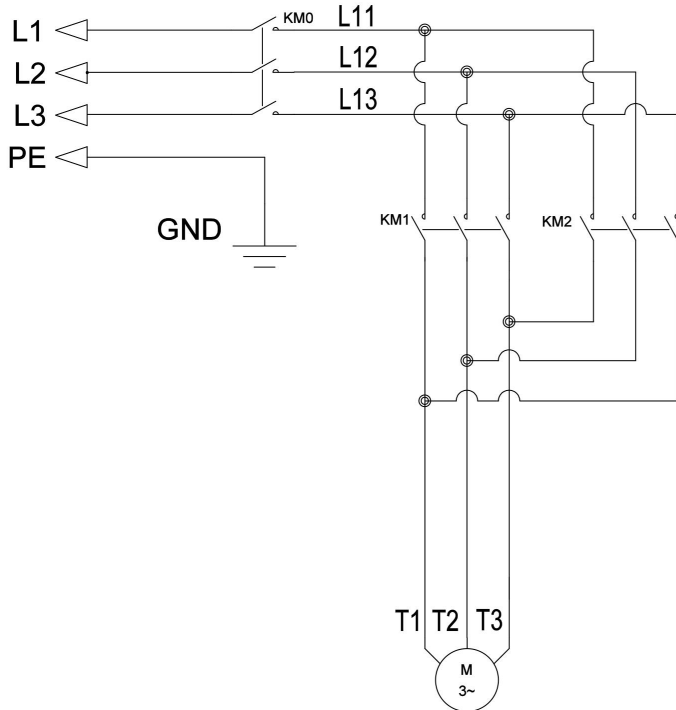

COM Plug

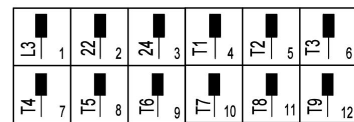

230V Socket

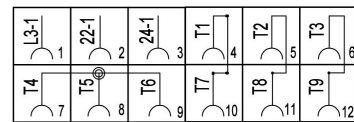

460V Socket

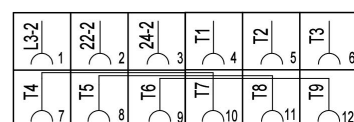

XT2	L1	L2	L3	L3-1	L3-2	00	01	20
	1	2	3	4	5	6	7	8