

Media Converters

The time for fiber is now.

How media converters make fiber a practical and economical option for horizontal cabling.



Standalone Converters

Modular Chassis Systems

Hybrid Converter Systems

724-746-5500 | blackbox.com/go/MC

Table of Contents

Introduction	3
Why Ethernet over Fiber?	3
Speed.....	3
Security.....	3
Resistance to electromagnetic noise.....	3
Distance	3
Cost	3
Future proof.....	3
Media converters—the migration tool for fiber connectivity	4
Media converter features and options	4
Interfaces	4
Layer 1/Layer 2	4
Form factor.....	5
SNMP management	6
Power options.....	6
WDM.....	6
Hardening	7
Link loss passthrough.....	7
Media converter applications	8
Copper-to-fiber conversion in the data center	8
Fiber to the desktop (FTTD).....	9
Migrating to faster network speeds in the LAN.....	9
Adding fiber segments anywhere in the LAN.....	9
Bridging LANs over fiber	9
Transitioning from SONET	10
Conclusion.....	10
About Black Box	10

We're here to help! If you have any questions about your application, our products, or this white paper, contact Black Box Tech Support at **724-746-5500** or go to **blackbox.com** and click on "Talk to an Expert." You'll be live with one of our technical experts in less than 30 seconds.

Introduction

Network backbone and long-distance applications have long taken advantage of fiber optic cable.

However, horizontal fiber cabling has been widely regarded as impractical and too expensive. After all, this is an application that doesn't need to cover long distances or move vast amounts of data and fiber is regarded as expensive and difficult to install. Copper is still the dominant cable type in local networks.

But times have changed and fiber is gaining an edge over copper—especially for new installations—and is now often the first choice, even for horizontal cabling, which has traditionally been copper.

In this white paper, we examine the uses and benefits of the most commonly used media converters—UTP-to-fiber media converters—and how these simple devices are the key to efficiently and economically migrating your infrastructure to take advantages of the benefits of fiber.

Why Ethernet over fiber?

Fiber optic cable is the only medium that can support a virtually limitless bandwidth. As the demand for more bandwidth grows and the price of fiber declines, fiber is making inroads where copper has been traditionally used, with fiber Ethernet as the preferred protocol for transporting data. Ethernet over fiber makes sense because of its low cost, simplicity, and scalability.

Speed

Applications are getting more demanding, Web sites are getting more complex, and everything is going to the cloud—these are all factors that drive the demand for network bandwidth. To accommodate the high network speeds needed to meet this demand, copper cable has evolved in a series of steps from the CAT3 that carried 10-Mbps 10BASE-T Ethernet all the way to CAT6a, which can carry 10-Gigabit 10GBASE-T. UTP has gone through at least five generations to keep up with increasing bandwidth requirements.

Fiber, on the other hand, has a much higher innate carrying capacity, so when network speeds increase, fiber can handle it without the need for costly upgrades.

Security

Fiber is more difficult for hackers to tap into. Because a copper cable “leaks” electromagnetic signals, a hacker can read data nearby without actually touching the cable. A fiber cable, on the other hand, uses light that stays within the cable, so a hacker must physically tap into it to gain access to data.

Resistance to electromagnetic noise

Fiber is immune to electrical noise such as electromagnetic interference (EMI) and radio-frequency interference (RFI), caused by items such as machinery and fluorescent lights.

Distance

Most common copper Ethernet standards have a maximum segment length of only 328 feet (100 m). Fiber, on the other hand, has distance limitations measured in kilometers, not meters. Although distances vary, multimode fiber cable routinely supports distances of two kilometers. Single-mode fiber can support distances over 10 kilometers, with some implementations going to 80 kilometers or more.

Cost

At one time, fiber was universally more expensive than copper. Today, however, because manufacturing costs are down and terminations are easier, fiber may be less expensive than the equivalent copper infrastructure

Because the major expense in laying fiber is labor, multistrand fiber can be installed for little more than a single pair, laying the ground for future expansion. Many installers prefer to work with fiber because of its smaller diameter, lighter weight, and ease of testing. Once installed, fiber optic cables' maintenance costs are significantly less than copper ones. The savings only increase over the life of the network, because fiber enables network upgrades without recabling.

But the real savings in using fiber are because fiber reaches farther than copper. Large copper LANs require network switches to cover longer distances. Switches require wiring closets with their attendant expenses and inconvenience. Fiber, because it covers far longer distances, can be centralized in the data center, often doing away with wiring closets altogether.

Future proof

Whether you “take the plunge” now or later, installing fiber in the horizontal is a way to ensure that your network cabling keeps up with the growth in network traffic, runs 10-Gigabit data rates, and supports future applications.

Media converters—the migration tool for fiber connectivity

With the considerable cost and performance advantages of fiber, one would think that every network would have a completely fiber horizontal structure running from a fiber port on a data center switch to a fiber port on a PC.

But in the real world, copper is often installed simply because it's more familiar. Plus, many network devices have copper ports, and organizations can't afford to replace the most expensive components of their networks—the electronics—to install fiber.

There's a simple workaround that enables the use of copper network ports for fiber: media converters. These simple devices provide the copper-to-fiber connectivity that enables organizations to gain the advantages of an all-fiber network without replacing existing equipment.

Media converter features and options

Media converters may be simple devices, but they come in a dizzying array of types. Newer media converters are often really switches, which confuses the issue even more.

Although today's converters support many different data communication protocols—including Ethernet, T1/E1/J1, DS3/E3, and ATM, in this paper, we're examining only the most common media converter family—copper-to-fiber Ethernet.

Interfaces

Ethernet media converters are available in many configurations, with the most common being UTP to multimode or single-mode fiber, although UTP to Thin coax (ThinNet), UTP to thick coax (standard Ethernet), Thin coax to fiber, and UTP to SFP are also available. On the copper side, most media converters have an RJ-45 connector for 10BASE-T, 100BASE-TX, or 1000BASE-T connectivity. The fiber side usually has a pair of ST or SC connectors, although newer compact connectors such as LC and MT-RJ are becoming increasingly common. Media converters may support network speeds from 10 Mbps to 10 Gbps.

Media converters are the key to integrating fiber into a copper infrastructure, making it possible to migrate a local network to fiber while extending the productive life of existing infrastructure.

On the most basic level, media converters are simple networking devices that make it possible to connect two dissimilar media types. Although the most common type of media converter connects UTP to fiber optic cable, media converters may also connect other cable types such as coax.

Media converters are often used to connect legacy Ethernet equipment with copper ports to new fiber cabling. They may also be used in pairs to insert a fiber segment into a copper network to increase cabling distance.

Layer 1/Layer 2

Traditional media converters are purely Layer 1 devices that only convert electrical signals and physical media. They don't do anything to the data coming through the link so they're totally transparent to data. These converters have only two ports—one port for each media type—and support one speed.

Some media converters are more advanced Layer 2 Ethernet devices that, like traditional media converters, provide Layer 1 electrical and physical conversion. But, unlike traditional media converters, they also provide Layer 2 services—in other words, they're really switches. This kind of media converter often has more than two ports, enabling you to, for instance, extend two or more copper links across a single fiber link. They usually feature autosensing ports on the copper side, making them useful for linking segments operating at different speeds.

The introduction of Layer 2 converters has blurred the line between media converters and switches—the same device may be called a media converter or a switch by different vendors.

Media converters work with many different interfaces, including:



The ST® connector for fiber uses a bayonet locking system.



The SC connector for fiber features a molded body and a push-pull locking system.



The LC connector is a small-form-factor fiber connector that features a ceramic ferrule. It looks like a mini SC connector.



The MT-RJ connector for fiber has a molded body and is a small-form-factor RJ-style connector.

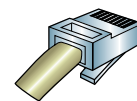

The RJ-45 connector is a modular connector used with UTP copper cable.



SFP, SFP+, and XFP transceivers adapt a media converter with a compatible slot to virtually any interface.

Form factor

Media converters are available in standalone models that convert between two different media types, in chassis-based models that connect many different media types in a single housing, and in hybrid systems that feature standalone modules that also work in a chassis.

Standalone converters have their own enclosure and power supply. These media converters are used individually to convert between two cable types. They're used either in pairs to extend a network over fiber, or as remote units to a modular chassis-based system. Small standalone media converters easily tuck behind a PC to bring fiber to the desktop. These compact converters are ideal for use in small networks and for connecting remote sites, but can quickly be outgrown as your network expands.

Chassis-based or modular media converter systems consist of chassis that house media converter modules. Chassis are usually rackmountable, although desktop chassis are also available and also provide power to the media converters. Chassis-based media converters are used primarily in data centers when many Ethernet segments of different media types need to be connected in a central location.

These media converter systems offer great port density, but modules can't be used on their own without a chassis—to use an individual module, you must install it in a compatible chassis. These systems are usually SNMP manageable.

Chassis systems provide unparalleled flexibility and enable mixing slide-in converters as required. For example, when combined with a 10/100/1000 Ethernet switch, LAN administrators can use modular converters to satisfy a wide range of requirements in network connectivity and distance, converting copper switch ports to multimode or single-mode fiber as needed. Modules in chassis systems are usually hot-swappable, enabling quick network changes without taking the chassis off-line.

Hybrid media converter systems feature standalone media converters that can also be used in a rackmount chassis. Although these blended systems generally don't offer the high-end management features of enterprise-level chassis-based systems, they do offer a great deal of versatility and value because each media converter can be used and reused where it's needed most, whether it's mounted in a rack in a data center or working as an individual standalone unit on a desktop.



Standalone media converters are best for small networks and as remote units for chassis-based media converters. They're ideal for fiber-to-the-desktop applications.



Chassis-based media-converter systems consist of modules that work in chassis that are usually rackmounted, although there are also smaller chassis for desktop use. These systems usually feature SNMP management and are best for data center use in large, enterprise networks.



Hybrid systems have media converters that can be used alone or in a rackmount chassis. These systems provide a great deal of versatility, although they usually do not include the robust management options common to chassis-based systems.

SNMP Management

Simple Network Management Protocol (SNMP) is the near universal standard for managing and monitoring large networks and WANs that span multiple sites. SNMP enables network administrators to minimize network downtime by quickly isolating problems and making fewer visits to remote sites. It reduces the time and money it takes to get a network up and running again.

By using a common set of standards, SNMP enables network administrators to manage, monitor, and control their SNMP-compliant network equipment with one management system and from one management station. SNMP enables an administrator to set up alarms or traps when a link is down and turn features on and off from a central terminal. If a network device goes down, it's possible to both pinpoint and troubleshoot the problem more efficiently. With SNMP, it's possible to detect a failure, isolate it to a specific port, and determine what hardware is required to repair it. This ability to quickly identify and isolate problems enables LAN administrators to maximize network uptime.

Media converter systems intended for large enterprise networks often have SNMP capabilities, either in a managed media converter chassis or built into individual media converters or media converter modules. And network administrators aren't limited to equipment from just one vendor—it's easy to integrate an SNMP-managed media converter system into a managed network because SNMP is a near universal standard.

Power options

Standard media converters come with an AC power supply that plugs into a standard wall outlet. It may be 120-VAC for domestic U.S. power only or may be an autosensing 120–240-VAC power supply that can be used domestically or easily converted to European power with a simple plug adapter.

When media converters are used in areas that don't have convenient power outlets, they may be powered by Power over Ethernet (PoE), which provides power to network devices over the same Category 5 or higher UTP cable used for data. PoE media converters may also provide power via PoE to a PoE-powered device such as a security camera or wireless AP.

Small standalone media converters intended mainly for fiber-to-the-desktop applications may be USB powered, enabling them to draw their power from a PC's USB port.

In chassis-based media converter systems, media converters or media converter modules draw their power from the chassis, which avoids the clutter of individual media converters that must be individually powered.

Industrial media converters have demanding power requirements. Because there's a great deal of variation in the power supplied to industrial sites, industrial media converters are either sold entirely separately from their power supply or are available with a choice of power supplies. Unlike standard networking devices, industrial media converters often require you to select the correct power supply for both device and application.

WDM

Media converters may support Wavelength Division Multiplexing (WDM) technology. WDM uses two or more wavelengths—usually 1310 nm and 1550 nm—on one strand of fiber to increase the transport capacity of the fiber. Although it's usually associated with carrier backbone applications, WDM in the LAN is useful in situations where fiber is in limited supply or expensive to provision. Media converters with WDM support support full-duplex data transmission up to 70 kilometers on a single strand of fiber.

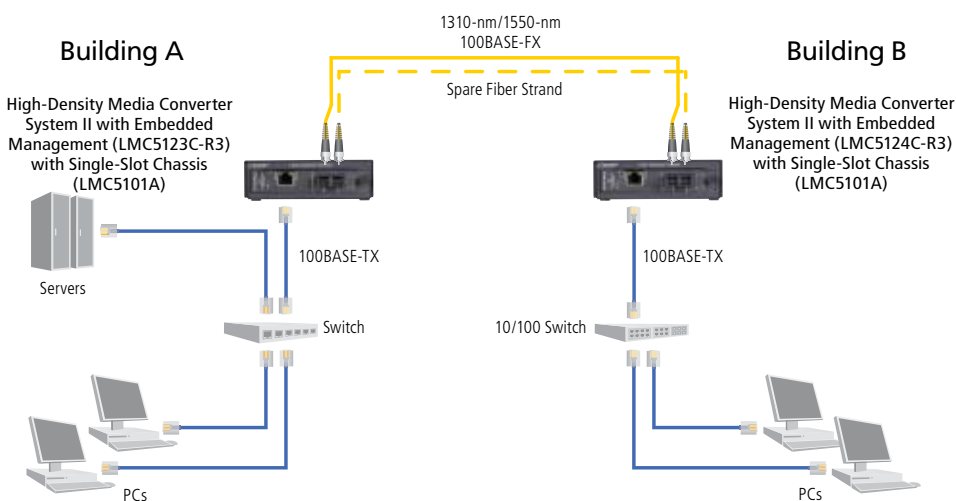

WDM media converters combine 1310-nm and 1550-nm wavelengths onto one strand of fiber, effectively doubling fiber capacity.

Hardening

Hardened, or industrial, media converters are intended for use outdoors or in areas that may be exposed to temperature fluctuations, moisture, dirt, and electromagnetic interference.

Hardened media converters are rated for a specific temperature range. Temperature tolerances from -13 to 140° F (-25 to +60° C) are common and you can even find media converters rated for extremes to -40 to +167° F (-40 to +75° C).

These media converters are usually housed in hardened metal cases that are sealed against contaminants including particulates such as airborne dust, as well as moisture, and sometimes chemicals. Conformal coating is a special film or coating applied to electronic circuitry to provide additional protection from contaminants. Hardened media converters are often designed to be DIN rail mounted or have separate brackets for DIN rail mounting.

Media converters for industrial applications are usually built to withstand higher EMI than those intended for office or data center use.

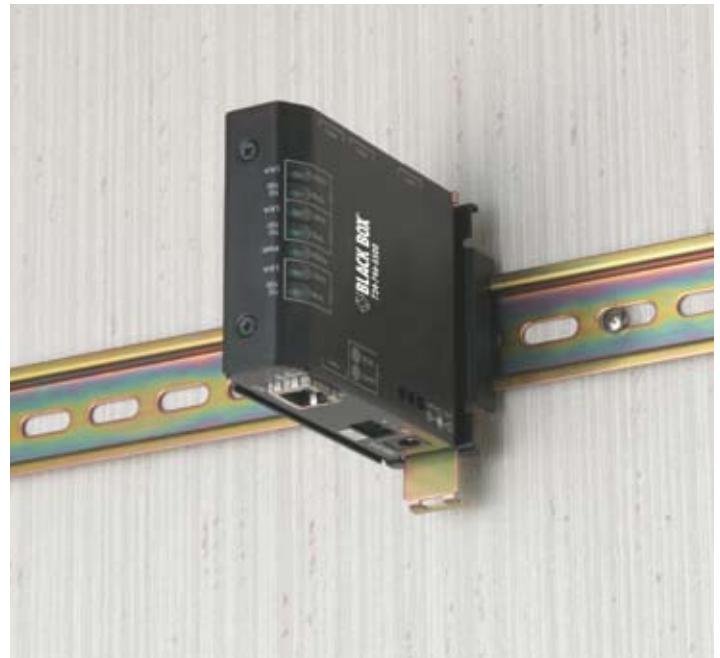

Hardened media converters are often designed to be mounted on DIN rail, an industry-standard metal rail commonly used in industrial sites.

Link loss passthrough

When a network device such a switch detects that a link is broken, the “Link” indicator on its front panel goes out, alerting the network administrator that the connection is lost.

The situation becomes a bit more complicated, however, when the switch has a media converter between it and its primary link. In this case, the switch can detect that the link to the media converter is broken but can’t detect a broken link on the other side of the media converter. If the fiber link goes down, the switch doesn’t notice because it still “sees” the media converter.

To counteract this problem, media converters commonly have a feature called link loss passthrough, which simply means that the media converter passes the news of a broken link onward.

In other words, when either a twisted-pair or a fiber link is broken, the information about this link loss is transferred to the other media link. For example, when a cable breaks on the fiber segment of a conversion, link loss passthrough detects the error and shuts down the twisted-pair link. The switch connected to the twisted pair notices that the link is down and its green Link LED goes out. If the switch also has SNMP management, it will send an SNMP trap to alert the network administrator of the broken link.

Depending on the vendor, link loss passthrough may appear as a trademarked (™) compound name containing the words Link, Loss, Alert, or Fiber. Although there may be minor variations in the way they work, these are all basically link loss passthrough.

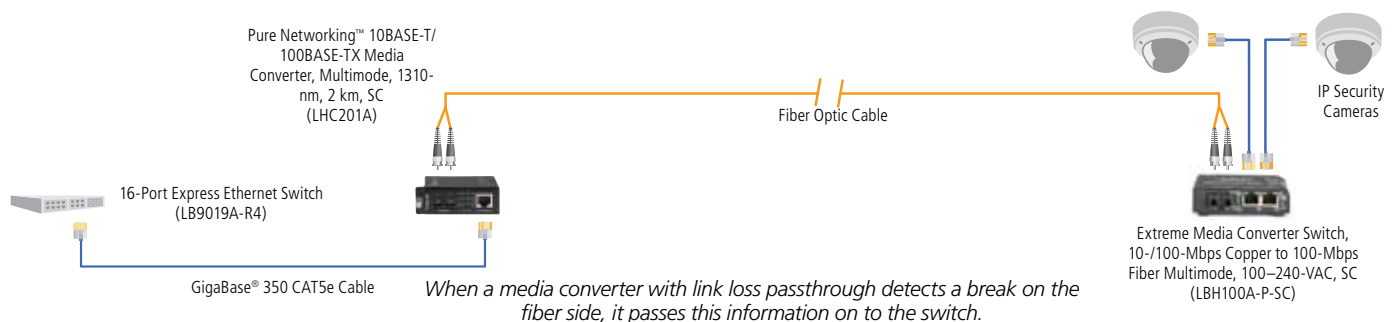

Media Converter Applications

Fiber is already established for LAN backbone applications, and now it's making inroads in horizontal cabling. Fiber carries more data than copper, making it more suitable for high-throughput applications such as streaming media and VoIP. Additionally, as the price of copper rises, the price of installing fiber continues to fall, making it an economical choice as well.

But there are factors standing in the way of migrating copper infrastructure to fiber. First of all, there's the familiarity factor—if IT staff is familiar with copper, they're likely to continue to install copper, even if it's not the best choice.

Another major factor preventing the migration to fiber is the cost of changing network devices out for fiber versions—an enterprise switch is a major investment and there is also the cost of adding fiber NICs to desktop PCs, as well as other networked devices such as printers and wireless access points.

Copper-to-fiber media converters help to ease the financial shock of migrating network equipment to fiber. They're a simple, inexpensive solution for matching copper ports to fiber infrastructure.

From the data center to the desktop, from the CO to the home—media converters are bringing fiber connectivity to areas where copper has long been the medium of choice.

Copper-to-fiber conversion in the data center

In the data center, media converters extend the productive life of existing copper-based switches, providing a gradual migration path from copper to fiber. Chassis-based media converters mount in racks alongside network switches, enabling the conversion of copper ports on legacy switches to fiber.

Media converters can also be used with new copper switches that have fixed RJ-45 ports, which are significantly less expensive than the equivalent fiber switches. Here, network managers can convert only selected copper ports for multi-mode or single-mode fiber as needed, bringing versatility to the data center while bringing overall costs down.

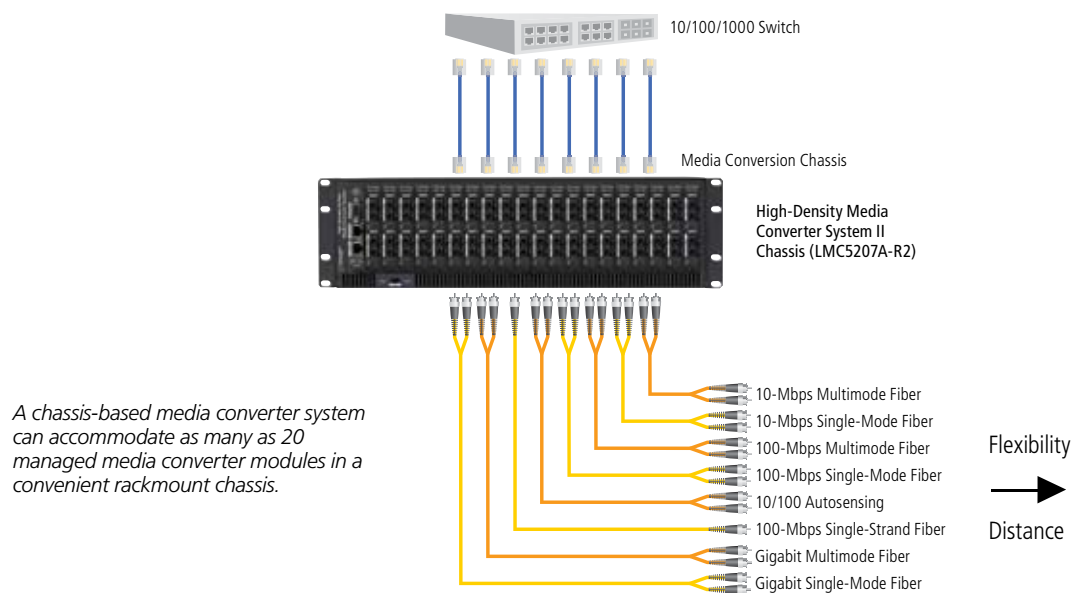

A chassis-based media converter system can accommodate as many as 20 managed media converter modules in a convenient rackmount chassis.

Fiber to the desktop (FTTD)

Media converters can bring down the cost of fiber to the desktop. Instead of expensive fiber home runs requiring all-fiber switches, patch panels, and network interface cards, media converters in the data center and again at the desktop create a network that has the advantage of being virtually 100% fiber, while retaining existing network devices. Because they enable the use of existing copper ports, media converters provide the benefits of fiber while reducing costs.

At the desktop, a standalone media converter tucked behind the PC connects a fiber cable to a PC's RJ-45 Ethernet port. A media converter is generally an easier way to bring fiber to a desktop PC than a fiber NIC because the NIC not only takes up a slot in the PC, but often creates driver issues that must be resolved. Media converters, on the other hand, are transparent to data—no setup or drivers are required. Plus, when nearby power outlets are in short supply, some media converters can be powered via a PC's USB port.

Migrating to faster network speeds in the LAN

Switching media converters provide a simple way to connect legacy 10BASE-T network segments to a newer 100-Mbps infrastructure, or for connecting 100-Mbps Fast Ethernet to Gigabit Ethernet infrastructure at a lower cost than using a larger switch to accomplish the same goal.

Adding fiber segments anywhere in the LAN

Because media converters are easily installed anywhere in the network, they can be used to insert fiber segments into copper infrastructure for additional cabling distance, to reduce electromagnetic interference, or to support high-speed applications.

Because media converters are so convenient and easy to use, they're a perfect first step to 100% fiber infrastructure.

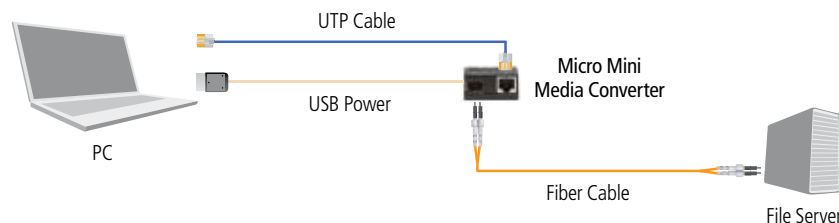

Media converters quickly connect any PC with an RJ-45 Ethernet port to fiber infrastructure.

Bridging LANs over fiber

LANs can be linked with fiber to form a WAN across a limited geographic area—this implementation is often referred to as a metropolitan area network (MAN). Premise cable is primarily copper with its 328-foot (100-m) distance limit. Fiber supports longer runs between buildings. In fact, media converters can extend the reach of the LAN over single-mode fiber 80 kilometers (49.7 mi.), or more through the use of 1550-nm optics.

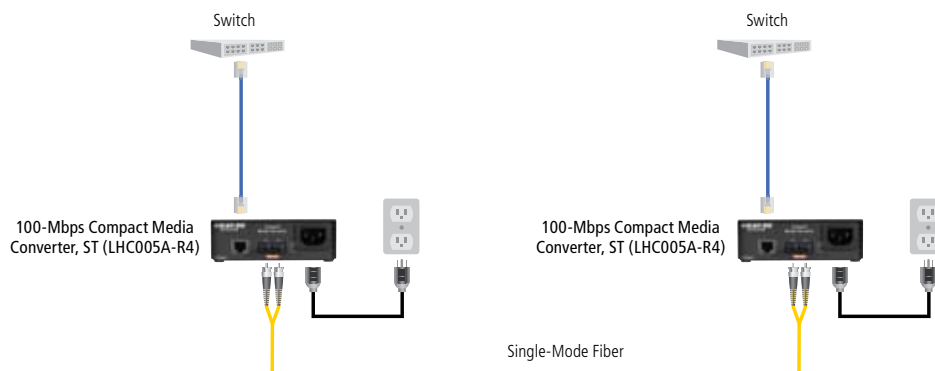

Bridging two LANs with single-mode fiber and two media converters.

Transitioning from SONET

Media converters help ease the transition from older fiber technologies—particularly SONET—to Ethernet.

Many businesses still use fiber SONET for WAN connectivity, but this technology is time-consuming and expensive to maintain, as well as better suited for voice than data.

Ethernet on fiber offers significant advantages to SONET in terms of cost, scalability, and ease of administration. By using media converters to link to fiber, network administrators quickly adapt the fiber previously used for SONET to Ethernet.

Ethernet offers many advantages including lower cost, easier integration into existing networks, and the ability to throttle link speeds.

Flexibility in network design is another area in which Ethernet has a major advantage. SONET operates only in a ring topology; Ethernet lends itself to a wide range of topologies including ring, linear, tree, star, and hybrid.

SONET Ring Topology

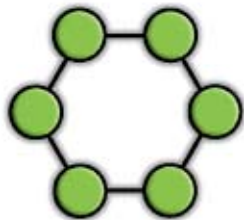

Ethernet Topologies include:

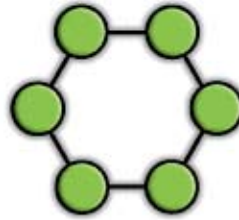

Ring topology

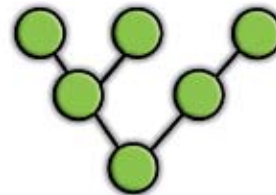

Tree topology



Star topology

An advantage of converting SONET to Ethernet is that, although SONET is limited to a ring technology, Ethernet supports a wide range of topologies including ring, tree, star, line, and hybrid.

Conclusion

The convergence of multiple services—data, voice, video, and more—onto Ethernet has increased demand for bandwidth, making fiber almost a necessity in today's high-speed networks. When you add the fact that fiber has become more affordable and easier to deploy, it's no wonder it's increasingly being used for horizontal infrastructure and for first/last mile applications.

Media converters extend the productive life of existing equipment while enabling it to keep pace with new fiber infrastructure, protecting your network investment during the migration from copper to fiber. Plus, they're simple to install and can easily be reused in other areas when network interfaces are upgraded to fiber, further leveraging the original investment.

The bottom line is that media converters make practical sense. These simple, cost-effective devices are the key to taking your network into the future with fiber.

About Black Box

Black Box Network Services is a leading connectivity provider, serving 175,000 clients in 150 countries with 200 offices throughout the world. The Black Box catalog and Web site offer an extensive range of products including media converters, network switches, and infrastructure products. To view Black Box's comprehensive line of products, see blackbox.com.

Black Box is also known as the world's largest technical services company dedicated to designing, building, and maintaining today's complicated data and voice infrastructure systems.

© Copyright 2012. All rights reserved. Black Box® and the Double Diamond logo are registered trademarks of BB Technologies, Inc. Any third-party trademarks appearing in this white paper are acknowledged to be the property of their respective owners.