

I am currently in my 8th year of teaching within education having spent most of my contact time delivering agriculture, welding/fabrication and various variants of vehicle and machinery technology and the ancillaries that make up these machines to a wide range of learners. In my time my own abilities have developed and evolved which has impacted my core delivery methods and topics. Having started with the standard what do learners need to know to achieve their qualification within the area they have selected, to the now stretching and challenging methods of delivery which revolves around what new technology and new fields of study will open doors to the learners that are passing through my classroom. It is for this reason I have been working on this and other projects which both interest and motivate learners (and equally myself). It is true that learners will be working on technology that is ever changing and becoming more complex so it is paramount to keep up to date with current systems and assemblies.

The project started originally with an idea. Whilst looking at the new emissions regulations that have been implemented to tractors and power units in conjunction with motor vehicle technology. (see previous bursary write up 2014). My emissions indicator went through many stages of development (mainly caused by problems with my own abilities and comprehension of the subject). Having spent time looking at data generated and working within the remit of the scope that I was constrained to new questions were opened up. Mainly concerning fuel delivery and ad blue injection. Technology has evolved now to comply with the ever tightening emissions regulations. What options are there I wonder for people who have machinery that is working outside the parameters set by manufacturers e.g. is it possible to change fuelling to alter emissions and efficiency for the better. All end consumers are concerned with both economy and emissions whilst not affecting the serviceability and predicted life span of the unit. All these questions based around the educational context and learning experiences to students at my current employer.

Picture the scene, as an engine developer you have produced the best most efficient engine, it runs perfectly, produces torque in the right places when required and has excellent economy. That engine is then sent to transmissions, they fit all of the bolt on ancillaries and suddenly changes are needed to e.g. increase engine rpm when air conditioning is activated or to produce more torque when the engine is stressed through the PTO, these changes are made and then the unit goes to emissions control who need to change fuelling when the DPF filter is carrying out a regeneration/ times of ad blue injection or in full exhaust gas recirculation mode (technology to ensure compliance with tier and euro regulations present and future developments). This process continues until the vehicle finally rolls off the production line with all these modifications needed to allow it to comply with emissions legislations and power requirements within the country of its destination (also a variable that must be factored as differing end users have different legislative requirements). The vehicle now has been modified from what the design team created. It is for this reason standard ECU's are given approximately 25% grace to change and allow modification. Mapping figures quoted commercially for (i.e.) e.g. a John Deere 6030 premium are 20% economy 40nm increase in torque, fuel saving 15% resulting in a real time increase of 30 bhp. Most machines can be remapped due to mass production resulting in commonality between tractor, combine, forager etc. Once access is given to one system many are available. There are however many other systems which cannot be

readily accessed in this way such as braking and safety features. As is commonly known within the agricultural sector horsepower, and to a degree torque is measured by drawbar and PTO. The main and most widely used method is via the PTO through a dynamometer. Stock engines are often de-rated to suit the application, the ECU and engine is still capable however of producing more. Manufacturers commonly offer software upgrades now to the end user (at a price).



Dynamometer in use carrying out static PTO hp test, for above machine stock 50 hp claimed at PTO, actual hp 58 at PTO. This is a 16% increase, and a fuel saving of approximately 6% although this depends on the activity being undertaken. The test engine has approximately 200 hours currently. Maximum hp at PTO 62 at 400rpm above rated PTO output and brought down to 540 under engine load. Evidence suggests that it is clearly possible to change the characteristics of an engine dependant on its purpose to encourage clean running and economy. With the addition of aftermarket wideband lambda sensor it is possible for the operator to see where the machine is running outside these parameters and make running modifications if possible. The above Dynamometer cannot show torque back up unfortunately.



Quoted figures comparing stock with remapped engine for JD 6215r

Key for colours on graph

Red manufacturers HP

Black re mapped HP

Blue manufacturer's torque

Green re mapped torque

Fuel mapping a brief introduction.

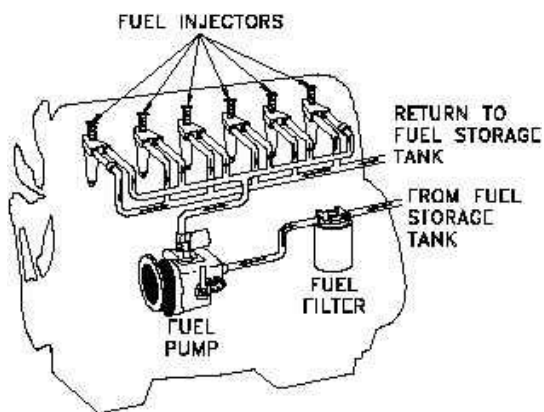

Consider the picture above, now a largely obsolete layout due to emissions legislations. Fuel was picked up from the tank and sent through micron filters. Pressurised and metered by the injection pump often by mechanical means for simplicity and technology availability and sent to the injectors, fuel delivery was governed largely by mechanical systems running off engine rpm and the governor that was moved by the throttle lever. This system evolved into many versions and there were a few good attempts at changes e.g. Cummins pressure time system but largely working on the same operation with differences inside the pump.

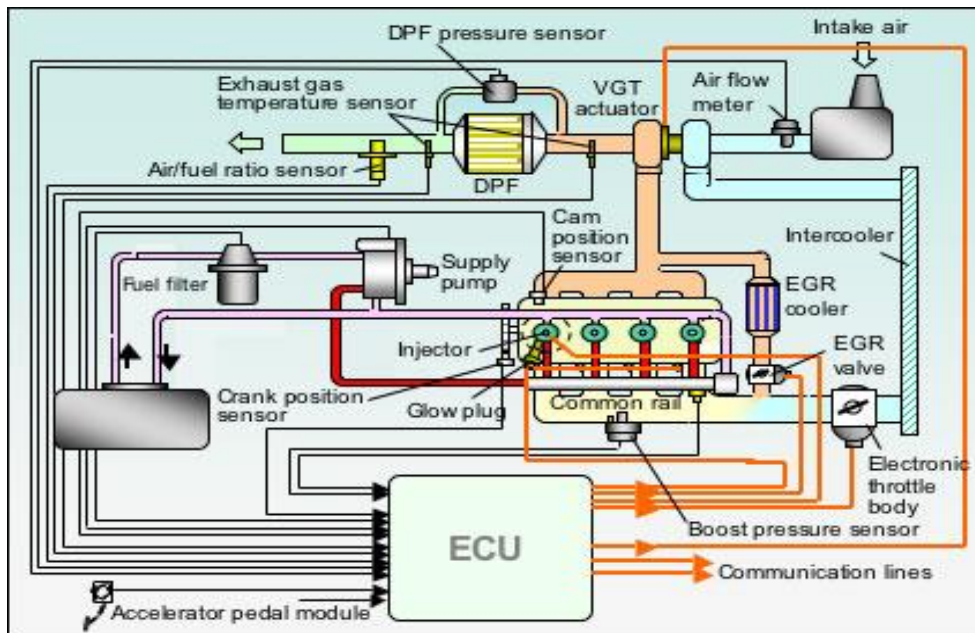

Although not all of the above is found on agricultural tractors, variants soon will become more commonplace as emissions become more stringent, tractors once built for simplicity have evolved due to emissions and user demands. Fuel is filtered and pressurised and sent to the common rail. The ECU is fed information from sensors such as airflow mass meter, throttle potentiometer, turbo boost pressure, DPF filter. All this information is computed and the engine control module, ECU will decide fuel timing and amount as well as the increments of phased delivery. It is the algorithms within this ECU which is dictating the fuelling. The throttle is now merely a small part of this process where the operator is saying “can I have “ and the ECU is dictating yes or no once the calculations and possible outputs have been computed. All of which happens in microseconds

The process

Main:-

Driver asks for engine output via the throttle position sensor (variable resistor via position of pedal).



ECU gets information from all sensors e.g. fuel temperature, exhaust temperature, demand of power on the crank, levels of oxides of nitrogen and diesel particulate filter back pressure, boost pressure, coolant temperature (as an example)



ECU fuels engine to parameters set by software torque limiters and corresponding maps



Torque is produced, input now varies due to i.e. soil conditions, driver input, load of implement, process starts over (return to main:-).

It is the unseen logic in the software that makes a vehicle run. Many maps are stored within the ECU to enable the engine to supply the fuel that it has been programmed to in hopefully all operating conditions designated by the programmers. Care must be undertaken to ensure the integrity of this software as without it vehicles become immobile. Software can be easily corrupted and damaged by incorrect maintenance and repairs (as well as incorrect tuning).

Fuelling is controlled by mapping. There are three ways of viewing, hexadecimal, table view (2d) and map view(3d). Hexadecimal is beyond the understanding within my remit so map and table view are the options I use to navigate this software.

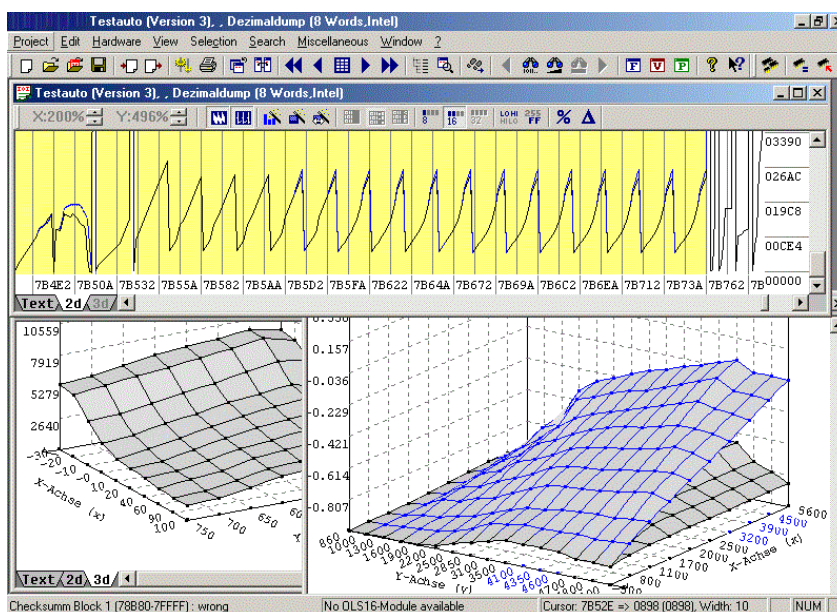

Typical map view



Typical table view

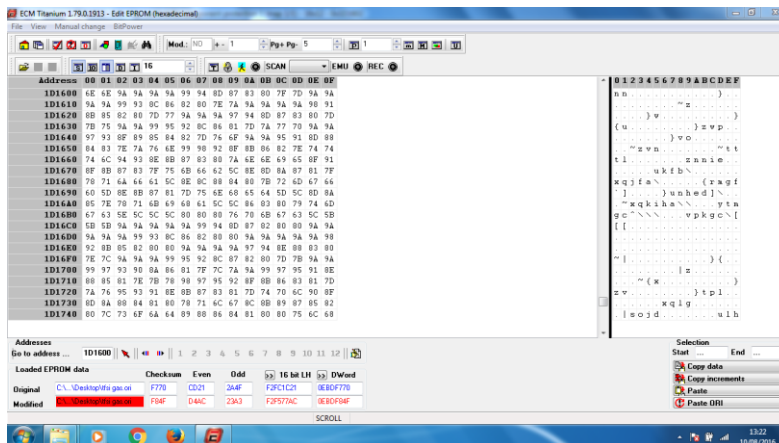

Hexadecimal view

Take the following images for example, all from a popular red machine currently available commercially.

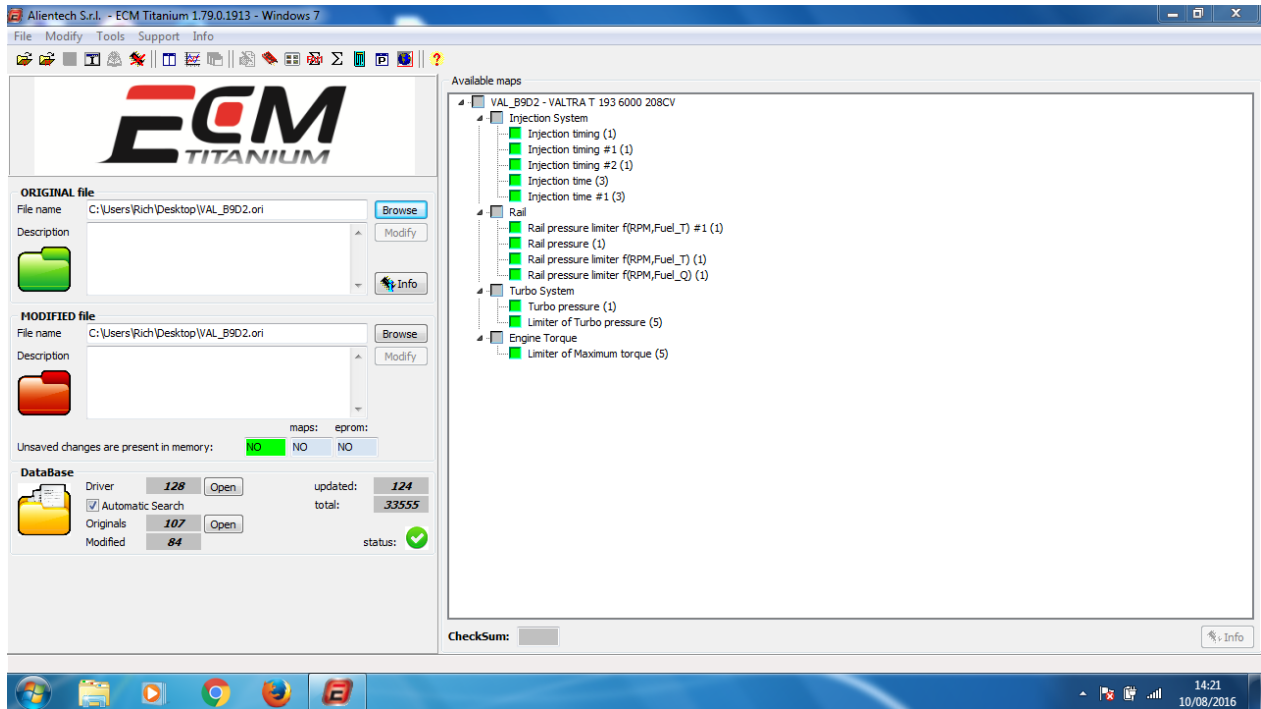

Above are the maps that can be modified within the power unit. In comparison a diesel car would have approximately 6 times the amount of maps due to the inclusion of more electronic sensors and actuators providing more options for modification (thankfully agricultural vehicles are required to be more resilient thus reducing sensor requirements and fuel table options, this will change though). The main ones that can be amended are limiter of maximum torque and rail pressure (other factors are possible to amend with caution). With amending these slightly a gross gain of around 6-10% for torque can be produced safely and easily. This will also affect fuel economy due to the torque being more readily available in the useable rpm range, this results in making the engine operate within a lower rpm range to produce the peak torque subsequently saving fuel (approximately 5-12% though this can also be modified to the end users requirements). Though small gains due to high torque numbers the output is significant in newton metres at the crank.

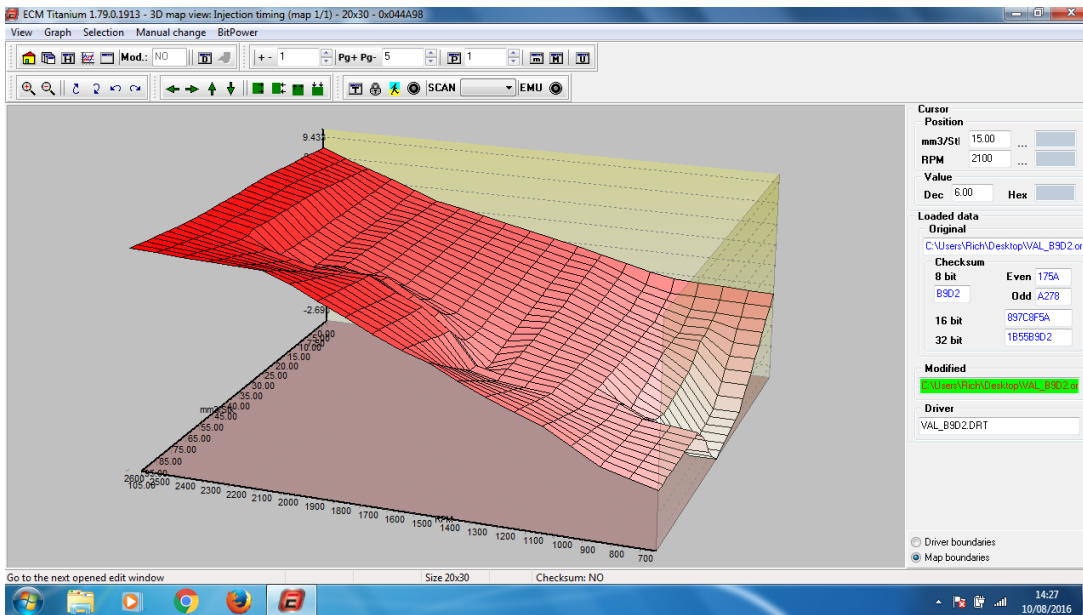
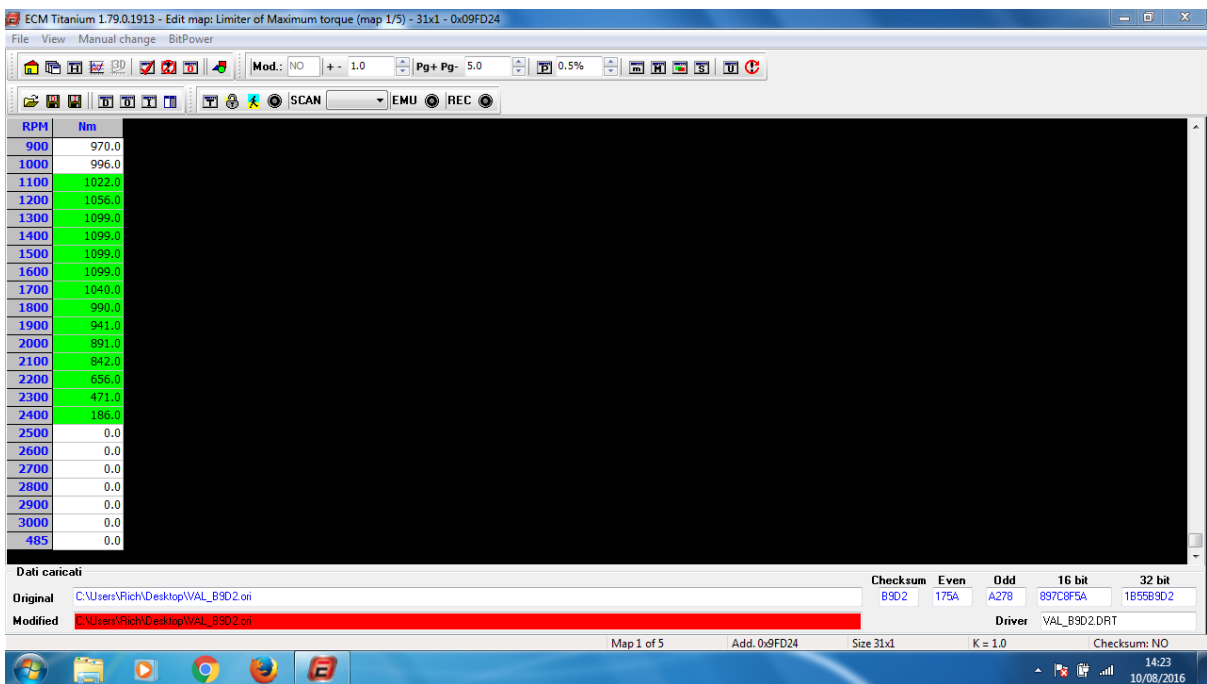

Table illustrating tractor timing maps. Contains 3 axis hence 3d format. Axis of rpm, torque requirement and fuel volume are apparent.



Above map showing torque limiter for the engine rpm output rpm versus nm. Green values have been modified.

The main limiting factors are within the cost of accessing such information and knowing how to read and modify. Technology such as this comes at a price. Many different systems are available all with

benefits and disadvantages. The ability to re map vehicles has been around for years in many forms, There are currently two main methods of re mapping

The first method considered safer is to access the vehicle through the diagnostic port found on most modern machines and access the ECU's tables and modify, the second often considered more dangerous is to open the ECU and bypass the diagnostic port (loosely termed anti tamper or anti tune, determined by tricore chip present in ECU. Although it has to be said manufacturers now have access to remotely access ECU via sim card built into vehicle so maps can be changed without operator's knowledge to fix bugs and change parameters. I am not aware of any companies other than the manufacturers having access to this entry point yet. This also allows for remote access to on board diagnostics for manufacturers. Although it must be noted as fast as technology changes to limit the casual users tampering, this technology is bypassed.

There are other methods such as replacing the ECU with a blank construct and setting your own tables inside, costly and time consuming, although more inputs and outputs can be added for greater control. Other methods include to fit chip tuning boxes which alter signals from sensors to cheat the ECU into fuelling to what it thinks is happening as opposed to the real live data. Some ECU's can have the chip replaced inside with new software parameters. All methods have advantages and disadvantages which have cost/output benefits.



Some of the test rigs I currently hold in stock.



Diagnostic socket mapping image above showing diagnostic port equipment.



Above showing ECU open anti tamper tricore remapping. Note the grey wire bypassing anti tune microprocessor which is the large black microprocessor roughly middle upper part of board



Probe showing bypassing tricore chip. (This process carries more risks than other methods due to the invasive nature of the process)



One of the farms live tractors. Alongside my Texa navigator and other diagnostic tools this provides an excellent teaching resource providing a good mix of real world machinery with modern technology. Power increase +18%, fuel saving to be calculated at later date with the addition and construction of flow meters to allow more accurate fuel analysis. Conservative estimations 4-7% saving annually.



Latest addition, 158hp claimed actual TBC. This particular machine is used for demonstration of GPS telemetry technology (machine produces too much horsepower for measurement on current dynamometer)



Above tractor one from my own personal fleet, although basic in technology and mechanical fuel control, this small machine has been subject to many Guinea pig tests before rolling out on more modern equipment. This machine is used for light duties and has proven to run cleanly when fitted with the emissions tester from previous bursary under all working conditions (once operating temperature has been reached).

Some of the data obtained so far in research

Example 1

Take the following table below, showing fuel consumption on tractor A in Litres per hour (this table is for stock mapping and economy, Machine is ploughing with 4 furrow reversible plough in the same field for all runs. I have broken the fuel consumption down into hours for more accuracy and to take into account varying factors.

Hour	Average fuel consumption in litres per hour
1	18.2
2	17.9
3	17.8
4	18.4

Over the 4 hour period fuel consumption is approximately 18.07 L/H

Tractor a modified

Hour	Average fuel consumption in L/H
1	17.1
2	17.3
3	17.6
4	17.8

Fuel consumption average 17.45 L/H

This results in approximately a 4% saving on fuel. I have left the make model etc intentionally missing as I do not want to become branded with machines or be unfair to manufacturers. To the best of my ability the machine was the same working temperature and working in the same topography and working conditions, however natural variances are possible. I have not mentioned soil type, weather etc at this stage fuel comparisons are my main concern.

Example 2

Again a stock engine running on the dynamometer in as controlled conditions as possible. (Times are shorter due to stresses on the engine). Engine working at rated horse power (the maximum the manufacturer claims should be run at). Run at similar start temperature to allow for heat sink.

In 20 minute sessions	Fuel consumption in 20 min
1	7.3
2	7.4
3	7.1
4	7.1

Average fuel consumption in 20 minute session 7.225 L (equates to 21.67 L/hour

The same Conditions with modified software

20 minute session	Fuel consumption per 20 min session
1	6.8
2	6.7
3	6.6
4	6.7

Average fuel consumption in 20 minute session 6.7 L equates to 20.1L/hour. This equates to approximately a 7% fuel saving. Things to note, this test should be more controlled compared to field analysis, The engine RPM was 120 RPM lower than the first run due to matching the horse power output of the engine, not the engine rpm. This may be due to changing the torque requirement of the engine output software. In each test shorter burst of 20 minutes were used to try and minimise engine stress and fatigue.

Example 3

This test is using a smaller hp rated engine. Again on the dynamometer running the similar conditions as test 2. Again at rated horse power

20 minute session	Fuel consumption per session
1	4.7
2	4.6
3	4.5
4	4.6

Fuel consumption per session 4.6L equating to 13.8L/H

20 minute session	Fuel consumption per session
1	4.5
2	4.5
3	4.2
4	4.1

Fuel consumption average per session 4.32L resulting in 12.97 L/H. Saving of 6% on stock. RPM 100 under stock.

As can be seen above the larger engines give greater savings compared to smaller engines but this may be because of the more scope to manipulate software equations. When tests have been carried out generally on engines that are running less than the rated hp i.e. an engine working at half load, the savings and % economy are also reduced. However it generally was considered better to run a larger engine on a lighter load, although I cannot substantiate this due to the nature of the measurements I could make with the equipment available. Due to the nature of field work difficulties in gaining exact like for like analysis is more complicated.

It is at this point that I must thank the Farmers club and the Douglas Bomford trust for their support with this project. Without their assistance none of this research would be possible. They have provided support and assistance in the hardware and training for myself and a fellow educational tutor to be able to undertake this research project and thus improve the knowledge and experiences for learners. My next aim is to get the new intake of learners in this academic year 2016-17 to continue the results and tests to further develop this, in conjunction with more accurate fuel metering and power analysis. By the very nature of these machines fuel consumption is difficult to measure, the machine working in a field has so many different factors affecting it, soil types, topography, air temperature, differing operators, it is difficult to obtain data unless connected to a static dynamometer to provide as controlled as possible data for analysis. Within this educational establishment funds have already been released for a rolling road dynamometer for expansion of this project and for delivery within other mechanical cohorts to increase their knowledge and delivery options as well as significant investment in new machinery for delivery to learners. My next step is to try and link motor vehicle technology further by using exhaust gas analysers used by our MOT testing department to critically analyse emissions in relation to fuel economy savings and power delivery. This will give significantly more detailed emissions comparison than previously used.