

AUGUST 2020

# International Cementreview

**MOVE OVER  
OLD-TIMER, NEW  
TECHNOLOGY  
COMING  
THROUGH!**

Up to 50% price reduction  
Greater cleaning power,  
eliminating Cardox and high  
pressure water washing

Greater reliability

Longer nozzle life



# A Monster task

Most air cannons in the cement industry use fan jet nozzles to provide a broad-ranging sweep of the area to be cleaned. However, this often means cement plants rely on additional cleaning methods for in-depth cleaning. A new type of nozzle could provide improved cleaning at depth while ensuring that a wide area is covered too.

■ by **Logan Shelton and Jeff Shelton**, *Integrated Global Services, USA*

The vast majority of air cannons in the cement industry employ a fan jet nozzle. That nozzle is designed to clean a wide area at the cost of penetration. It cleans between 1-1.5m into the application, but is often insufficient and requires supplemental cleaning methods.

Air cannon manufacturers have been slow to address this issue. Most nozzle innovations have only been successful at modifying the industry standard rather than reinventing it. Integrated Global Services (IGS) has spent the last few years on working out a new nozzle design: the IGS Monster Nozzle.

## Modifying the traditional fan jet nozzle

The design of the traditional fan jet nozzle (see Figure 1) requires a large cut in the applications and limits replacement options. The rectangular shape of the traditional fan jet nozzle requires the time-consuming process of taking out the refractory and repairing it once the nozzle is installed. A round fan jet nozzle was designed that allows the refractory to be removed with a core drill and eliminates refractory repair. With a 4in inlet and turning vanes, the modified fan jet nozzle (see Figure 2) eliminated installation challenges but the underlying issue remained: a cleaning area of 1-1.5m. As a result, many cement producers had to supplement this practice with manual rod cleaning, high-pressure water washing or carbox clean – expensive and high-risk methods.

## The IGS Monster Nozzle

Unlike previous innovations, the IGS Monster Nozzle is not a modification – it is an entirely new nozzle that penetrates deep into the application and generates more side-to-side cleaning.

Jeff Shelton, the inventor of the IGS Monster Nozzle, is no stranger to bucking industry trends. “I remember asking myself,

‘Why are people satisfied with a limited cleaning range?’ A better design would reduce the number of air cannons and lead to huge savings for cement producers”.

That simple question led to an R&D project. Jeff consulted with air flow experts and received a consistent message. “Everyone told us the same thing, ‘if you want to maximise the nozzle’s efficiency, you better maximise the mass flow rate. It is that simple’. Well, we took their advice seriously and designed our nozzle with that in mind,” he says.

The mass flow rate is defined as the mass of a substance which passes per unit of time. Therefore, IGS eliminated the turning vanes and expanded the inlet size. Those changes rapidly transfer the air from the tank to the application. The result is a briefer but far more powerful cleaning pattern.

Fan jet nozzles produce, on average, a mass flow rate of 9.8ibm/m. The Monster Nozzle produces a mass flow rate of 37.9ibm/m. “By getting the air out faster, the nozzle produces a cleaning blast with more weight behind it. That enables it to push through buildup and extend farther into the application,” he explains. But penetration does not come at the cost of side-to-side cleaning. “With the added weight driving deeper penetration, we could focus on the spray pattern. We wanted to double the side-to-side cleaning, so we designed the blast to get wide quickly. The end result is superior cleaning from side-to-side and front-to-back,” he adds.

The strength of the fan jet nozzle is side-to-side cleaning. However, the Monster Nozzle cleans twice as large an area as the fan jet nozzle (see Figure 4). Therefore, it reduces the total number of required nozzles by 50 per cent. Instead of cleaning a cement tower with eight air cannons, the Monster Nozzle enables the same level of cleaning with only four air cannons.

Figure 1: traditional fan jet nozzle



Figure 2: the modified fan jet nozzle has a 4in inlet and turning vanes

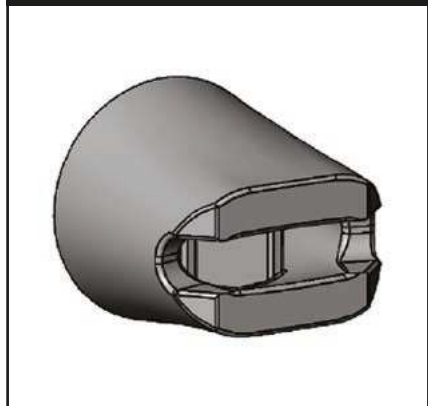

Figure 3: the Monster Nozzle has a larger inlet and no turning vanes





Figure 4: the Monster Nozzle (right) doubles side-to-side cleaning when compared with the fan jet nozzle (left)

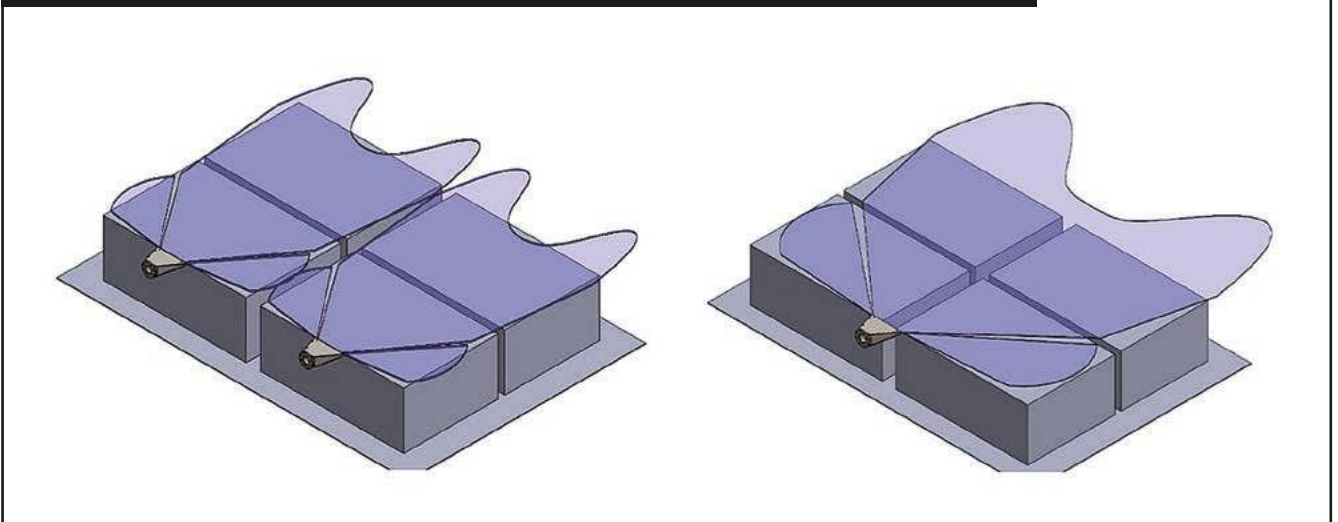
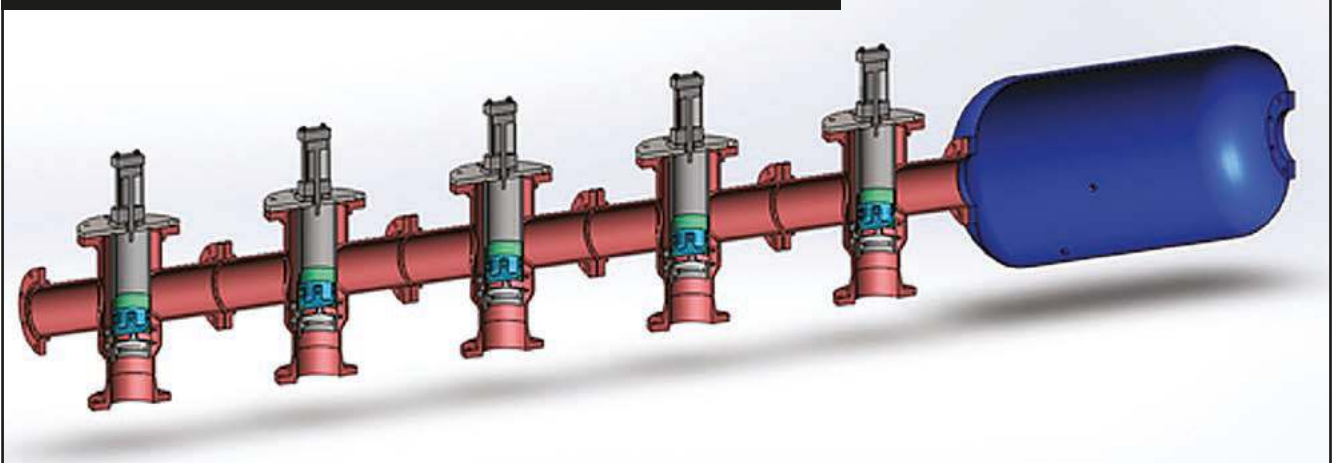

Figure 5: the IGS Multiplier enables one air cannon to discharge through up to eight ports



Unlike the limited in-depth range of the fan jet nozzle, the Monster Nozzle discharges with greater velocity and cleans a minimum of 3m into the application. This improvement eliminates the costs and hazards associated with supplemental cleaning methods.

### Generating savings

The Monster Nozzle will generate significant savings in terms of installation, replacement, operation and equipment costs for cement producers.

#### 1. Installation

The traditional fan jet nozzle is very expensive to install. Scaffolding and refractory work are often required, resulting in the average cost of about US\$2000/nozzle. The Monster Nozzle eliminates those concerns and can replace the modified fan jet nozzle easily.

#### 2. Replacement

IGS is the worldwide leader in metal

spray technology. It employs a patented Hastelloy coating to protect mission-critical equipment from corrosive processes. When the same coating is applied to the air cannon nozzle, it doubles the life expectancy.

#### 3. Operation

The Monster Nozzle eliminates the need for supplemental methods. This results in significant maintenance savings and reduces the risk of workplace accidents.

#### 4. Equipment

The Monster Nozzle generates the biggest savings to equipment costs. By doubling the side-to-side cleaning, it reduces the number of required air cannons by 50 per cent. These savings can increase exponentially when combined with the IGS Multiplier. The IGS Multiplier enables one air cannon to discharge through as many as eight different ports. In other words, eight 150l air cannons with fan jet nozzles can be replaced with a 1300l multiplier

with four Monster Nozzle discharge points. This system will cost less, clean more effectively and eliminate safety hazards.

### A new way of looking at nozzle technology

Since cement producers are increasing the usage of petcoke and producing difficult-to-clean build-ups, the industry demands more efficient air cannons. However, the economic environment requires less-expensive capital projects. The IGS Monster Nozzle could be the answer. "I think it's a game-changer. It's an entirely new way of looking at nozzle technology", said Mr Shelton. "The fan jet has been the industry standard for so long that no one really questioned it. That was the standard recommendation, so people just assumed it was best. But I totally reject that. There's always a better way. The Monster Nozzle is simply a low-cost technology that eliminates build-up. It yields an immediate ROI and enables capital funds to be directed elsewhere," he concludes. ■