

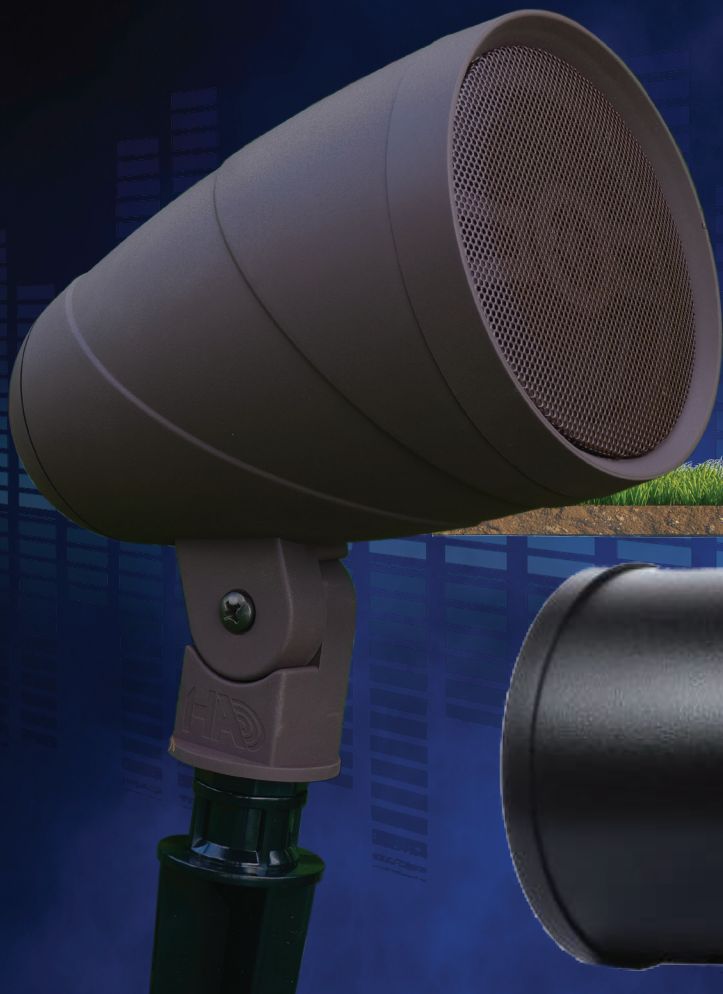

Heritage Acoustics™
Quality Sound at its Best!



LANDSCAPE AUDIO SOLUTIONS
SATELLITE SPEAKERS AND SUBWOOFER
FOR PROFESSIONAL/CONTRACTOR INSTALLATION

HERITAGEACOUSTICS.COM
LANDSCAPE 2019/2020



SAT-4 SATELLITE SPEAKER

8Ω/70v/100v Compatible **Sold As Each**

- Woofer: 4" (10.16 cm) PP Waterproof Cone w/ Rubber Surround
- Tweeter: .75" (1.9 cm) Marine Grade PEI Tweeter
- Impedance: 8Ω/70/100V
- Tap Settings: 70V- 4W, 8W, 16W, 32W, 64W 8Ω:
100V- 8W, 16W, 32W, 64W, N/C: 8Ω Bypass
- Frequency Response: 80Hz – 20kHz + 3dB
- Recommended Power for 8Ω System: 20~100W RMS
- SPL: 87dB @ 1w/1m
- Dimensions: 5" dia x 7.6"L x 7.7"H w/o stake (12.7x19.3x19.6cm)
- Unit Weight 3.6 lbs. (1.65kg)
- * Optional Mounting Accessories are available from Philips Hadco®
Surface Mount # MC1A / Tree Mount # TM1H



Smooth Sound, Built to Withstand the Elements.

Made of ASA* material for maximum UV Protection and the Rugged Outdoor Environment won't chip or peel; will withstand temperatures from -15°F to 160°F (-25°C to 70°C)

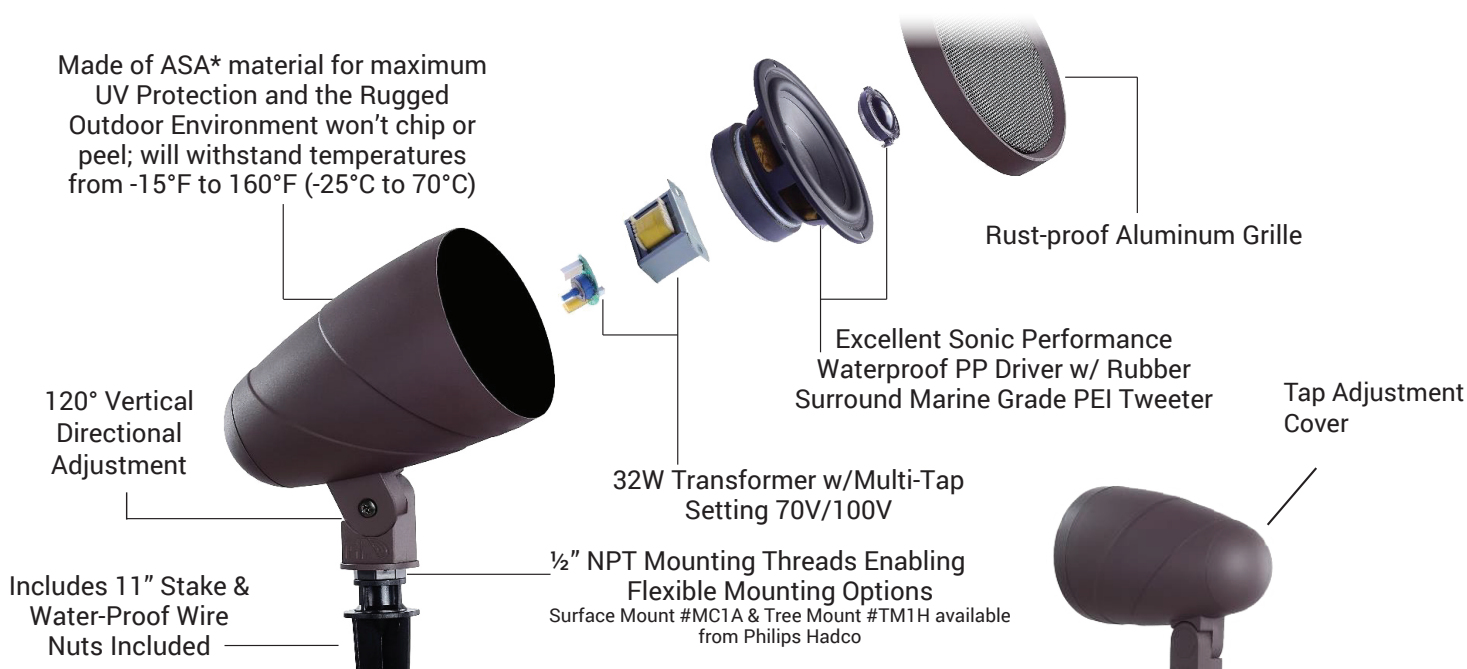



SUB-10 BANDPASS SUBWOOFER

8Ω/70v/100v Compatible **Sold As Each**

- Woofer: 10" (25.4 cm) PP Water-Proof Cone w/Rubber Surround
- Impedance: 8Ω/70/100V
- Tap Settings: 70V- 16W, 32W, 64W, 128W 8Ω:
100V- 32W, 64W, 128W, N/C: 8Ω Bypass
- Frequency Response: 30Hz~200Hz
- RMS Power Rating @ 8Ω: 200W
- SPL: 90dB @ 1w/1m
- Magnet Structure: 30 oz. Ferrite
- Dimensions: Woofer Enclosure: 12.7" dia. x 18.3"L (32.3 cm x 46.5cm)
- Canopy: 10.8" dia. (27.4 cm) • Unit Weight: 29 lbs. (13.1 kg)



Powerful Bass, Rugged Construction.

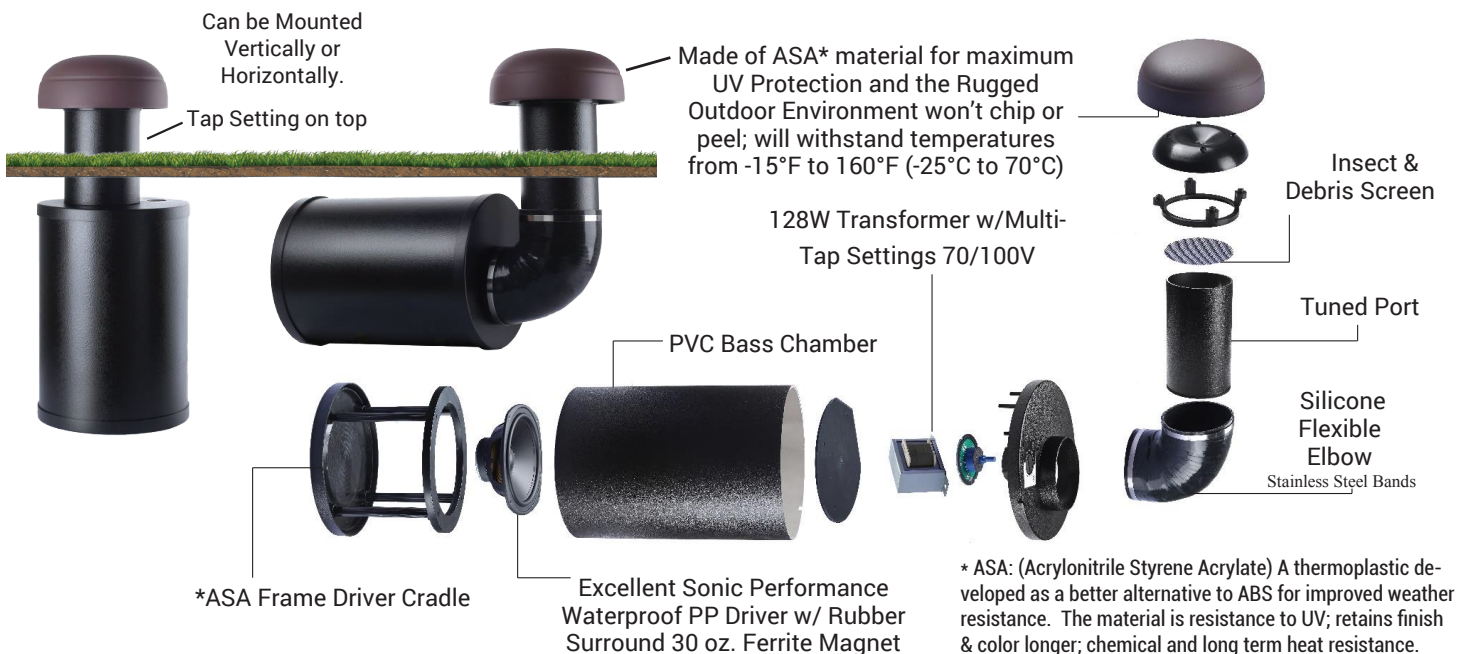



SUB/SAT SYS 1 - 70v/100v Professional Audio

Fully Scalable Commercial Audio System Sold as Packaged System

System Includes: CDi1000 Crown 500w x 2 Amplifier

SUB-10 Subwoofer & Four (4) SAT-4 Satellite Speakers



Installation Made Easy

The SUB/SAT SYS 1 ships with DSP setting preset in the amplifier by our tech support. System includes a Phoenix to RCA Connector for easy connection of an audio source requiring an unbalanced signal.

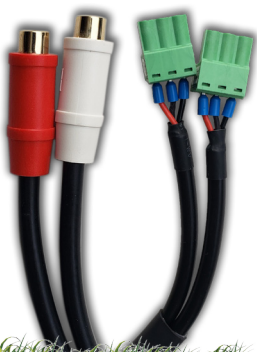



Heritage Acoustics distributed landscape audio packaged SUB/SATSYS1 system powered by CROWN delivers rich and full sound in any outdoor environment. Unleash the power of 500w x 2 channels for up to 20 Satellite Speakers to suit large and expansive properties or commercial premises. System includes 4 Sat-4 Satellites, Additional Sat-4 Satellites for expansion sold separately.



CROWN CDi1000 (500w x 2) Two Channel Power Amplifier

- Power Output: 500w x 2 @ 70V
- Sensitivity: 1.4v
- Signal to Noise Ratio: 100dB
- THD: -0.5%
- Damping Factor: +500
- Frequency Response: 20HZ – 20kHz
- Power Supply: Universal
- Dimensions: 17.313"W (19" w/ rack ears) 3.50"H x 15.0"D
- Weight: 21.9 lbs.
- USB Input: Allows use of Harman's System Architect Software





SUB/SAT 10.4 SYS - 8Ω Residential Audio

Hi-Fi Landscape Audio System Sold as Packaged System

System Includes: Subwoofer & Four (4) Satellite Speakers



Installation Made Easy

Expandable with direct output of any 2-channel receiver or Multi-Channel amplifier.

Most 2-Channel receivers are 4Ω stable
Check your equipment's specification.

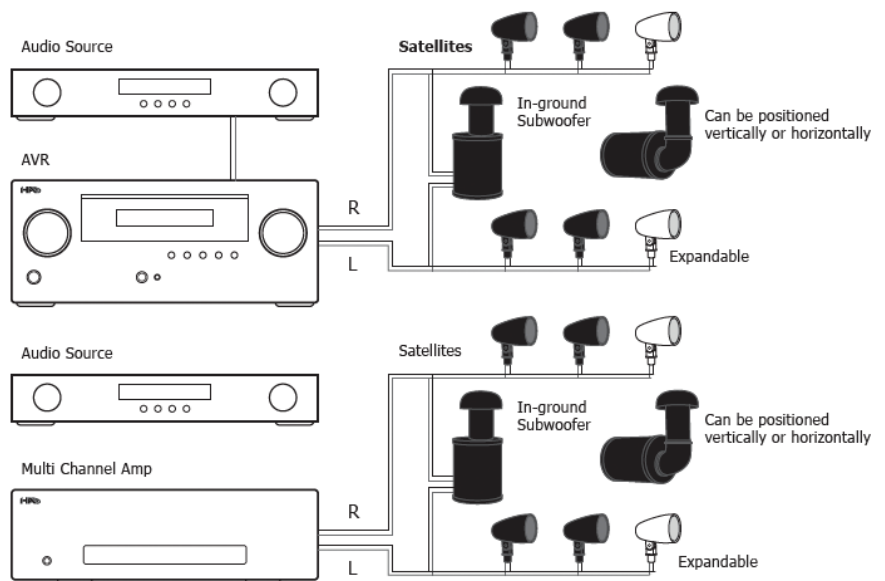



Heritage Acoustics SUB/SAT 10.4 is an easy to wire, easy to order, packaged system designed for small or medium landscaped areas. This system can be powered by most 2-channel receivers on the market.

SUB/SAT 10.4 Components

Specifications and size of SUB/SAT 10.4 SYS 8Ω System components slightly vary from SUB-10 and SAT-4 products and DOES NOT include 70v/100v transformers.

10.4 SUBWOOFER (Not Sold Separately)

- 10" (25.4cm) Dual VC Long Throw Driver
- PP Water-Proof Cone w/Rubber Surround
- Magnet Structure: 80 oz.
- Impedance: 8Ω
- Power Handling: 200W @ 8Ω
- Freq. Response: 40 - 85Hz +3dB
- SPL : 90 dB @ 1w/1m
- Bass Chamber made of PVC
- Tuned Port w/ Flexible Rubber Elbow
- Top Hat made of ASA material that will withstand the harshest weather conditions
- Overall Dimensions: 12.68" x 16.54" (32.2 x 42 cm)



SUB/SAT EXPANSION SPEAKERS (Pair)

- 4" (10.16cm) PP Waterproof Cone w/ Rubber Surround
- Tweeter: .75" (1.9cm) Marine Grade PEI Tweeter
- Frequency Response: 80Hz -20kHz
- SPL: 87 dB @ 1w/1m
- Recommended Power for 8Ω System: 100W RMS
- Made of ASA Material to withstand the harshest weather conditions
- Comes w/ 11" Ground Stake
- Optional Mounting Accessories are available from Philips Hadco®
- Dimensions: 5: dia. x 7.6"L x 7.7"H (w/o stake) 12.7 x 19.3 x 19.6 cm



SUB/SATEXP

May Add One Additional Pair to this system.



Heritage Acoustics™

HERITAGEACOUSTICS.COM

A Division of Astrosound Audio Co., Ltd

Quality Sound at its Best!

*5 Year Limited Express Warranty**

All Heritage Acoustics™ Landscape and Outdoor products are covered by a limited express warranty provided by Astrosound Audio Co., Ltd. and covers any defects in Heritage Acoustics™ products due to materials or workmanship for up to 5 years. This limited express warranty covers the original owner of the product who purchased it directly from an authorized dealer or distributor.

See full warranty details and disclaimers at www.heritageacoustics.com/Warranty

smato

Smato Experience Center

238A, AJC Bose Road, Sreepally,
Elgin, Kolkata, West Bengal, India
PS Plush, Unit 1C

Sales Contact:

Shreyans Chowdhary:
+91 98305 32810

**All specifications are subject to change without notice. *All trademarks and registered trademarks are property of their respective owners.*



Heritage Acoustics

