

TOWN OF CLEAR LAKE
111 GECOWETS DRIVE
FREMONT, IN 46737
www.townofclearlake.org
260-495-9158

Generator Permitting & Installation Requirements

Procedure Overview

Submit Improvement Location Permit (ILP) Application for a Generator, a site plan & all applicable fees to the Zoning Administrator.

Generator Installation Requirements

A. General Requirements

- 1) All work must be performed by Contractor registered with Steuben County.
- 2) Town inspection and approval of final generator installation required prior to use of generator. Use of generator without Town approval shall be considered violation and subject to fine.

B. Single-Home Grinder Installations

- 1) The electrical service for any homes with generators must convert the servicing sewer grinder from direct to residential utility service.

C. Residential Electrical Service Requirements

- 1) The direct electric utility service to the grinder must be disconnected at the pole in accordance with electric utility requirements. Disconnections at the grinder panel are not permitted.
- 2) An exterior electrical disconnect shall be provided. This disconnect shall provide ease of accessibility for the Town.
- 3) Residential service shall be 240V and provide 30A breaker in residence.

D. Town Contacts

- 1) Zoning Administrator: zoning@townofclearlake.org or Ph. 260-243-6701
- 2) Street & Utility Superintendent: superintendent@townofclearlake.org or Ph. 260-495-5902

FEES AND/OR CHARGES

ILP (Generator)	\$ 50.00	
NIPSCO Disconnect Fee	\$100.00	(PAID TO THE TOWN OF CLEAR LAKE)

ILP Application for Generator

Permit # _____

Applicant Information:

Name _____ Email _____

Address (Lake) _____ Address (Permanent) _____

Phone (Preferred) _____ Phone (Other) _____

Project Information

Project Address _____ Property Owner _____

Contact Info _____

Project Description _____

Type of Grinder: Single-Home Shared

Proposed Electrical: Residential Service

Estimated Start Date _____ Estimated Completion Date _____

- Provide a to-scale site plan illustrating the proposed improvements as submitted with the Improvement Location Permit application.

Applicant Signature

I certify that I am authorized to act on behalf of the property owner and to the accuracy of all information provided with this application including the site plan, survey, and dimensions of the proposed improvements. I understand that the Town of Clear Lake reserves the right to revoke this permit upon finding that the work performed is not consistent with the information provided in this application. Additionally, I grant the Town of Clear Lake and its agents the authority to enter the property during the application stage and construction to determine compliance.

Applicant's Signature _____ Date _____

Town of Clear Lake Grinder Electrical Requirement

- 240 Volt, 30 Amp breaker is needed for grinder
- If grinder is under 100 ft from shutoff 10 gage copper wire is needed from the breaker box to the exterior shutoff
- If grinder is over 100 ft from shutoff 8 gage copper wire is needed from the breaker box to the exterior shutoff
- Use Midwest U065P exterior shutoff. A different brand of exterior shutoff can be used with approval of the Sewer Superintendent
- Wiring to the exterior shutoff can only be copper wire, not aluminum

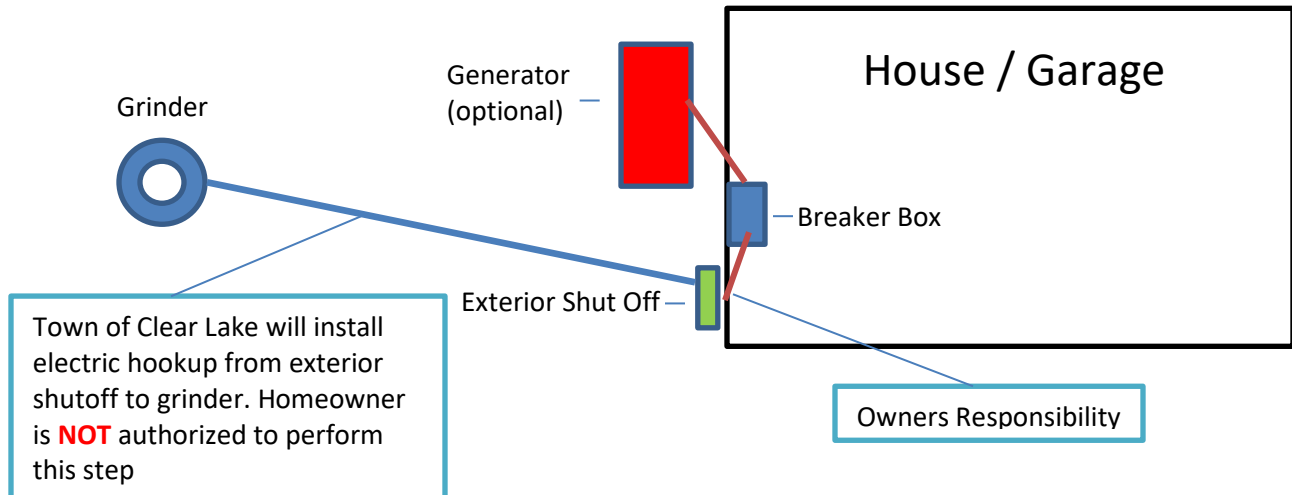

Midwest U065P 60A, 1P, 240V, Non-Fusible Disconnect Switch

