

AT4

Tourniquet System

Instructions for Use

Code 40080 - AT4 Electronic Tourniquet

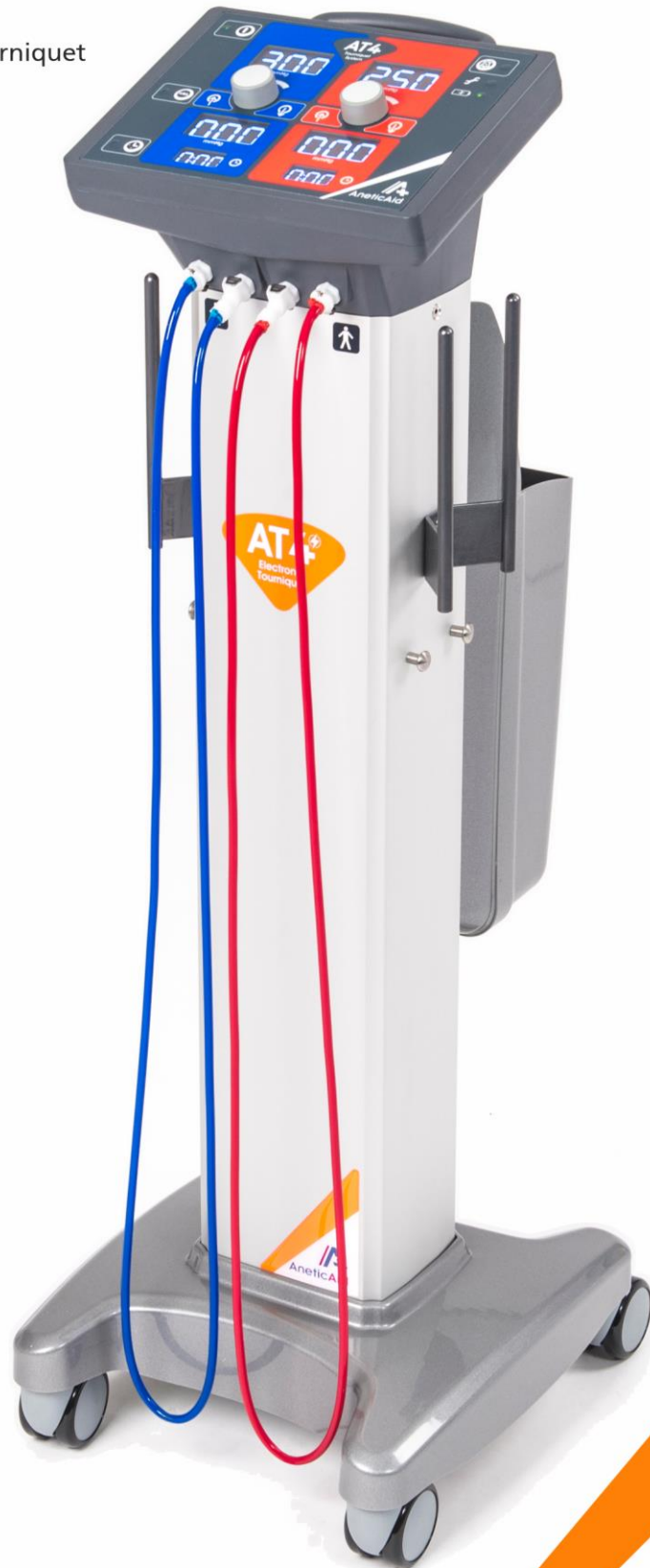

Contents	Page
1. Introduction	1
1.1. Warnings & Cautions	1
1.2. Intended User	1
1.3. Equipment Classification	1
1.4. Associated Devices	1
1.5. Serial Number Label	1
2. Summary of Warnings, Cautions and Side-effects	2
3. Symbols	3
4. Getting Started	5
4.1. Fitting the Fuse, and Charging the Battery	5
4.2. Connecting, and Storing, the Cuff Hoses	5
5. Product Functions	6
6. Controls and Operation	7
6.1. Preparation	7
6.2. General Operation	8
6.3. IVRA Operation	9
6.4. Alarms and Warning Indicators	10
7. Handling.	11
8. Performance and Technical Specification	11
9. Cleaning and Disinfecting	12
10. Installation of Battery	13
11. Expected Battery Life	14
12. Maintenance	14
12.1. Daily	14
12.2. Recurrent (Periodic) Testing	14
13. Product Warranty	14
14. Disposal of Waste Electrical & Electronic Equipment (WEEE)	15

1. Introduction

These instructions are intended to assist you with the operation of the AT4 Tourniquet and it is important that the instructions are read thoroughly and understood before using the equipment.

It is also important to check the tourniquet before use to ensure there is no loss or change in performance; ensure that all functions operate correctly and to their full range. We recommend that the tourniquet is visually inspected for any damaged parts, or contamination before use.

1.1. Warnings & Cautions

The European Medical Device Directive requires all manufacturers to include appropriate warnings and cautions and many of the warnings and cautions will apply to other similar devices.

To ensure that all users are well informed various warnings and cautions are made throughout these operating instructions.



A **WARNING** is given when the personal safety of the patient or user may be affected and when disregarding this information could result in injury.



A **CAUTION** is given when special instructions must be followed. Disregarding this information could result in permanent damage being caused to the trolley.

This product is intended for the control of pneumatic tourniquet cuffs in operating theatres or similar environments.

1.2. Intended user

Tourniquets should only be operated by trained and competent clinical staff and used in accordance with your establishments approved clinical practice.



WARNING: Intra Venous Regional Anaesthesia (IVRA) should only be administered by staff that have been trained and approved to carry out this procedure.

1.3. Equipment Classification

This tourniquet has been classified as a 'Class IIa' medical device in accordance with the European Medical Device Directive 93/42EEC as amended by 2007/47.

1.4. Associated Devices

The cuffs which may be used with this device are considered to be associated devices and will have their own instructions for use which should be read and understood. Any conflicts between the instructions should be resolved before use.

To ensure compatibility it is recommended that accessories and associated devices are supplied by Anetic Aid. Inappropriate bore size of the hose and compliance of the cuff can affect the stability of the pressure control.

Ensure that O rings on cuffs and associated hoses are in good condition before use.

1.5. Serial Number Label

The Serial and Reference Numbers are located on a label on the rear of the device. When requesting service ensure that both the Ref No and the Serial No are quoted.

2. Summary of Warnings, Cautions and Side Effects

In common with all medical devices of this nature there are inherent risks and side-effects that the user should be made aware of. Whilst every effort has been taken to eliminate these risks, care should be taken when using the tourniquet. It is important that the user familiarises themselves with all of the warnings and cautions contained within this document.

WARNINGS:



- The pressure and duration of application of a tourniquet cuff is a matter for clinical judgement. Application of a tourniquet cuff for excessive duration or at excessive pressures can result in tissue necrosis. The correct size and shape of cuff will allow cessation of blood flow at lower pressures and reduce the risk of tissue necrosis.
- Intra Venous Regional Anaesthesia (IVRA) should only be administered by staff that have been trained and approved to carry out this procedure.
- The castors are intended for positioning the tourniquet within the operating room they are not to be used for transportation over thresholds or steps.
- The AT4 should always be moved by pulling the handle it should not be moved by pushing.
- When the electrically powered AT4 is not in use it should be connected to the mains electrical supply to recharge the battery; see Section 10.
- It is recommended that only CE marked cleaning products are used in the cleaning of the AT4; see Section 9.
- Dilute all disinfectants in accordance with the manufacturer's guidelines; see Section 9.

CAUTIONS:



- Before use, ensure all device functions operate correctly. Also visually inspect the device for any loose or damaged parts. If the device performance changes from that specified or required the device should be taken out of service immediately.
- Maintenance work should only be conducted by suitably trained personnel following manufacturer's guidelines.
- Do not use concentrated solutions of bleach or disinfectant, organic solvents, abrasive powders or expose any part of the tourniquet to excessive heat. For cleaning and disinfection methods; see Section 9.
- Disinfectant products are corrosive in nature; failure to properly wash and dry the surfaces could leave a corrosive residue which may cause damage.
- Do not steam clean or jet wash any areas of the device or its detachable hoses or cables.
- Do not use concentrated bleaching disinfectant solutions, organic solvents, abrasive powders or expose any part of the device to excessive heat.

SIDE EFFECTS:





- Application of a tourniquet cuff for excessive duration or at excessive pressures can result in tissue necrosis. The correct size and shape of cuff will allow cessation of blood flow at lower pressures and reduce the risk of tissue necrosis.
 - Intra Venous Regional Anaesthesia (IVRA) if incorrectly performed can have catastrophic and even fatal side effects. The inclusion of a system to reduce the risk of errors should not be seen as mitigating or reducing the level of training and caution required when using IVRA. IVRA should only be administered by staff that have been trained and approved to carry out this procedure.
-







3. Symbols

The following symbols have been used on the AT4 tourniquet control panel;

Symbol:	Title:	Description:
	ON / OFF	Press to turn ON, Green indicator. To turn OFF press and hold until pressure displays are blank.
	AUDIBLE ALARM PAUSE	Press once to pause audible alarms for 3 minutes; Amber Indicator (except Low Battery).
	AUDIBLE ALARM OFF	Press second time to cancel audible alarms (except Low Battery). Red Flashing Indicator.
	INFLATE PRESSURE CONTROL	Turn to set inflation pressure blue channel. Turn to set inflation pressure red channel.
	PRESSURE SET OR APPLIED	Indicates the set and applied pressures.
	INFLATE	Inflates blue and red channels respectively.
	DEFLATE	Deflates blue and red channels respectively.
	IVRA	Selects IVRA control mode interlocking the controls of both channels. Amber indicates ready but not operational, green indicates operational, Red indicates incorrect action.
	TIMER REMINDER	Prior to inflation of cuff this button sets the reminder start time and repeater frequency. This function is cancelled after the cuff has been inflated. Audible Reminder is supported by amber visual indicator and flashing of the timer LCD and is cancelled by pressing the timer button.
	TIME	Indicates the timer display for blue and red channels respectively.
	BATTERY LEVEL	Green: represents acceptable battery level Amber: connect to mains as soon as soon as practical. Green/Amber: Charging. Red: connect to mains immediately.
	MAINTENANCE INDICATOR	Amber: Service required. Red: Stop using and request immediate service.

The following symbols are used on the AT4 tourniquet;

Symbol:	Title:	Description:
	CE MARK	Indicates compliance with the European Medical Device Directive 93/42 and amendments thereto. Symbol is associated with a number indicating the Notified Body.
	READ INSTRUCTIONS	Read Instructions For Use.
	CAUTION	Indicates the need for the user to consult the instructions for use for important cautionary information.

	FUSE	Location and value of fuses.
	BATTERY	Location and type of battery used.
	WEEE	Do NOT dispose of in domestic waste see Section 14.
V	SUPPLY VOLTAGE	Supply voltage of mains inlet.
~ Hz	SUPPLY FREQUENCY	Frequency of AC mains supply.
W Max	MAX POWER CONSUMPTION	Maximum power consumption in watts.
SN	SERIAL NUMBER	Unique serial number used for traceability.
REF	REFERENCE NUMBER	Reference or model number indicating the type of unit.
	DATE OF MANUFACTURE	Date of manufacture as YYYY:MM
	MANUFACTURER	Name and address of manufacturer is adjacent.
	Do Not Push	The AT4 should not be pushed as it is more stable when pulled by the handle.
	Rx ONLY	CAUTION: Within the USA Federal law restricts this device to sale by or on the order of a physician.

4. Getting Started

Packaging can be fully recycled, or reused.



During manufacture the base moulding and front panel are protected by a thin plastic film. The film, indicated with the symbol illustrated, should be removed during commissioning.

On receipt, or after periods of storage, the AT4 must be cleaned and disinfected before being put into clinical use.

4.1. Fitting the Fuse and Charging the Battery

For safety, the AT4 is shipped without the batteries being operational; the fuse is removed during final inspection. The unit will have been supplied with a T3.15A fuse in a clear plastic bag with the operating instructions; this needs to be fitted during commissioning.

Lay the AT4 on its back, and fit the fuse in the fuse holder indicated by the fuse symbol on the underside of the AT4.

On receipt, or after periods of storage, the AT4 must be connected to the mains electricity supply with the cable provided for 24 hours to allow the battery to be charged.

When fully charged the AT4 may be disconnected from the mains, and operated from the battery, avoiding the requirements for mains cable in the surgical area. The AT4 may also be operated while connected to the mains if the battery is low.

When not in use it is recommended that the AT4 be left connected to the mains to ensure that the battery is fully charged and ready for use.

4.2. Connecting, and Storing, the Cuff Hoses

The AT4 will have been supplied with Red and Blue cuff hoses. These should be connected to the connections on the front of the AT4 and below the appropriate red or blue segment of the front panel. There are two connections to pressurise the cuff, and two connections which are for stowage of the cuff end of the hose when not in use.

5. Product Functions

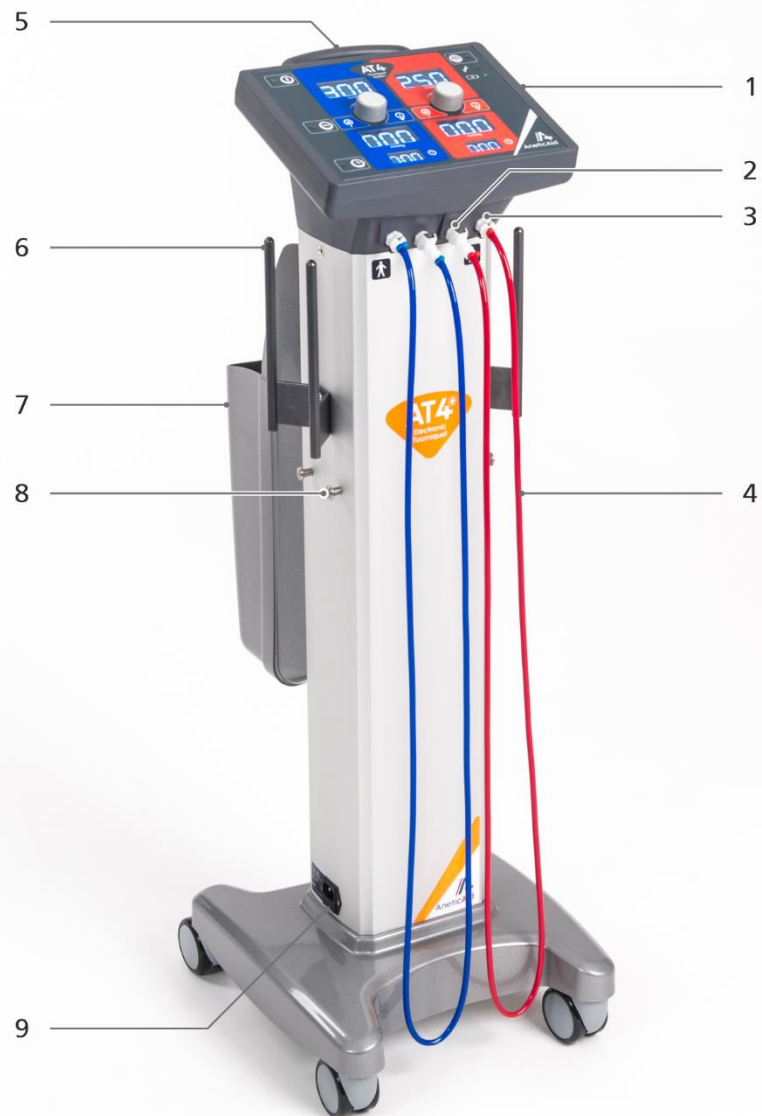

1. Control Panel
2. Cuff Supply Hose Storage Connectors
3. Cuff Supply Hose Connectors
4. Cuff Supply Hose
5. Pulling Handle
6. Cuff Hooks
7. Storage Facility
8. Additional Storage Facility Locating Pins
9. IEC Socket

6. Product Controls and Operation

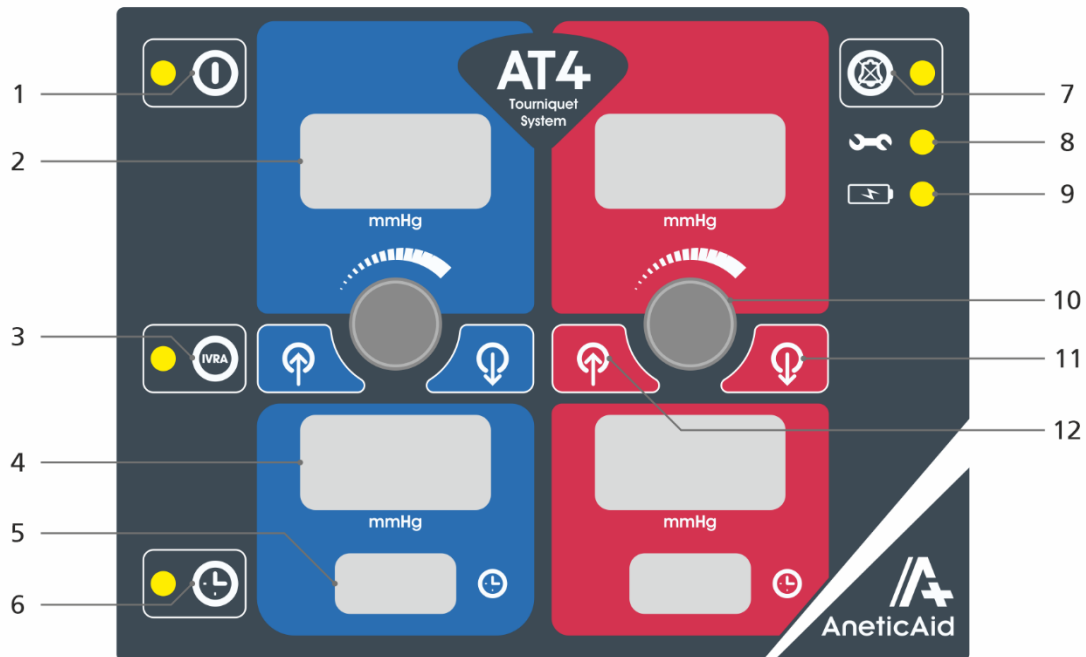

1. ON/OFF
2. Set Pressure display
3. IVRA (Intravenous Regional Anaesthesia)
4. Applied Pressure display
5. Elapsed Time H:MM
6. Reminder control
7. Audible Alarm, pause and indicator
8. Maintenance indicator
9. Battery Level indicator
10. Pressure controller
11. Deflate button
12. Inflate button

6.1. Preparation

Ensure that the battery has been charged and the battery indicator is green; if not it must be used connected to the mains supply.

The red and blue cuff hoses should be connected to the connectors in the front of the AT4 ready for use below the appropriate red or blue segment of the front panel. There are two connections to pressurise the cuff and two which are for stowage of the cuff end of the hose when not in use.

Select the appropriate size and type of cuff(s) and apply to the patient's limb(s). The correct size and shape of cuff will allow cessation of blood flow at lower pressures and reduce the risk of tissue necrosis.



CAUTION: Before use, ensure all device functions operate correctly. Also visually inspect the device for any loose or damaged parts. If the devices performance changes from that specified or required, the device should be taken out of service immediately. Ensure that O rings on cuffs and associated hoses are in good condition before use.

6.2. General Operation



The AT4 requires to be turned by depressing the ON button. The green light will be displayed.



By default the Timer Reminder is set to commence at 90 minutes (1.30) and repeat at 15 minute intervals. Before a cuff is inflated the Timer Reminder option may be set by repeatedly depressing the button until the required option is obtained. The option is momentarily displayed in the lower displays the left display being the time to the first reminder and the right display setting the frequency that the reminder repeats.

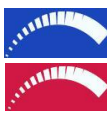

Set the required pressure on the desired channel by rotating the control clockwise to increase and anticlockwise to decrease. The selected pressure in mmHg is displayed in the window above the rotary control. Application of a tourniquet cuff at excessive pressures can result in tissue necrosis.



To inflate the cuff depress the inflate button associated with the pressure set in the previous step.



The Timer Reminder will sound at pre-set intervals and can be cancelled until the next scheduled reminder by depressing the Timer button.



To deflate the cuff depress the deflate button associated with the cuff a single push initiates a slow deflate a second depression initiates a fast deflate. During deflation the screen will flash.

If bilateral operation is required the second cuff can be inflated at any time without affecting the first channel.



When the procedure is finished press the off button to turn the AT4 off as this will conserve battery life.

If the AT4 is not turned off it will automatically shut down if the cuffs have not been inflated for 15 minutes.

When not in use it is recommended that the AT4 be left connected to the mains to ensure that the battery is fully charged and ready for Use.



CAUTION: When not in use it is essential that the tourniquet is disconnect from the cylinder or that the cylinder valve is turned off. High precision regulators by the nature of their design vent a small amount of gas even when not in use and this can deplete the cylinder contents even when the tourniquet is not in use.

6.3. IVRA Operation



WARNING: Intra Venous Regional Anaesthesia (IVRA) should only be administered by staff that have been trained and approved to carry out this procedure.



The AT4 requires to be turned by depressing the ON button. The green indicator will be illuminated.



By default the Timer Reminder is set to commence at 90 minutes (1.30) and repeat at 15 minute intervals. Before a cuff is inflated the Timer Reminder option may be set by repeatedly depressing the button until the required option is obtained. The option is momentarily displayed in the lower displays the left display being the first reminder and the right display setting the frequency that the reminder repeats. With default of 1:30 for first reminder and 15 for repeat

To implement the IVRA mode depress the IVRA button.



The green indicator will be illuminated.



Set the required pressure on the first channel (Upper cuff) by rotating the control clockwise to increase and anticlockwise to decrease. The selected pressure in mmHg is displayed in the window above the rotary control. Application of a tourniquet cuff at excessive pressures can result in tissue necrosis.



To inflate the cuff depress the inflate button associated with the pressure set in the previous step. If this button is depressed prior to setting the pressure levels above, the device will lock out. To reset turn the IVRA button off and then back on to start the process again.



Set the required pressure on the second channel (Lower cuff) by rotating the control clockwise to increase and anticlockwise to decrease. The selected pressure in mmHg is displayed in the window above the rotary control. Application of a tourniquet cuff at excessive pressures can result in tissue necrosis.



To inflate the cuff depress the inflate button associated with the pressure set in the previous step.



The first cuff can be deflated when the second cuff has been inflated.



The Timer Reminder will sound at pre-set intervals and can be cancelled until the next scheduled reminder by depressing the Timer button.



To deflate the cuff depress the deflate button associated with the cuff a single push initiates a slow deflate.



When the procedure is finished, to turn the AT4 off, press the off button and hold down until the pressure displays turn blank then release the button.

Turning off after use will conserve battery life. If the AT4 is not turned off it will automatically shut down after both cuffs have been deflated for 15 minutes.

When not in use it is recommended that the AT4 be left connected to the mains to ensure that the battery is fully charged and ready for Use.

6.4. Alarms and Warning Indicators



CAUTION: A number of Alarm and Indicator functions have been included and due note and actions should be taken.

Maintenance:



The spanner symbol with a red indicator requires investigation. If the indicator is not cleared by replacing leaking cuffs hoses and O rings and then restarting the AT4 a service should be requested. The AT4 has integral calibration and leak detection monitoring and an alarm which is not cleared by the above procedure may indicate failure of a pressure sensor or a leak in the internal pneumatic circuit.

Battery Level:



The battery level alarm indicates:

When the Electrically powered unit is being used while *NOT* connected to the mains supply the following indications apply;

Amber: Low battery connect to mains as soon as soon as practical

Red: Extremely low battery, connect to mains immediately

Green: Normal operation condition

When the electronic unit is connected to the mains supply but *NOT* in use;

Amber: Indicates connection to the mains. This is *NOT* an indication of battery level (see Battery Charging Section 9.)

When the electronic unit is being used while connected to the mains supply;

Green/Amber: Alternating Green/Amber indicating connection to the mains while in use.

NOTE: The amber indicator will take approximately 30 seconds to extinguish after disconnection from the mains

Timer Indicator:

The timer indicator can be set as preferred see section 5.2 and 5.3 but will as a default commence at 90 (1.30) minutes and repeat at 15 minute intervals. Application of a tourniquet cuff for excessive duration can result in tissue necrosis.

Excessive Pressure Indicator:

When pressures above those normally applied are selected an audible indicator will sound. Application of a tourniquet cuff at excessive pressures can result in tissue necrosis.

Low Pressure:

When the cuff pressure is reduced below those normally applied an audible indicator will sound. In the event that there is a catastrophic loss of pressure such as the disconnection of a cuff hose the alarm will sound and will be cancelled when the pressure is re-established or the deflate button is pressed.

IVRA:

If the IVRA option has been activated pressing an incorrect inflate or deflate button will generate an audible indication that the function is not appropriate and has not been implemented.

7. Handling

CAUTION:



- The AT4 should not be pushed as equipment is more stable and controllable when pulled by the handle.
- The castors are intended for repositioning the AT4 within the operating room environment or on other smooth level surfaces and slopes up to 10°. They are not intended for negotiating steps, thresholds or other obstacles such as cables or hoses.
- If required to be lifted up a step or over a threshold the AT4 should be lifted by the cuff hooks on the side of the unit. Do not lift the AT4 by the control panel as this may result in damage.

8. Performance and Technical Specification

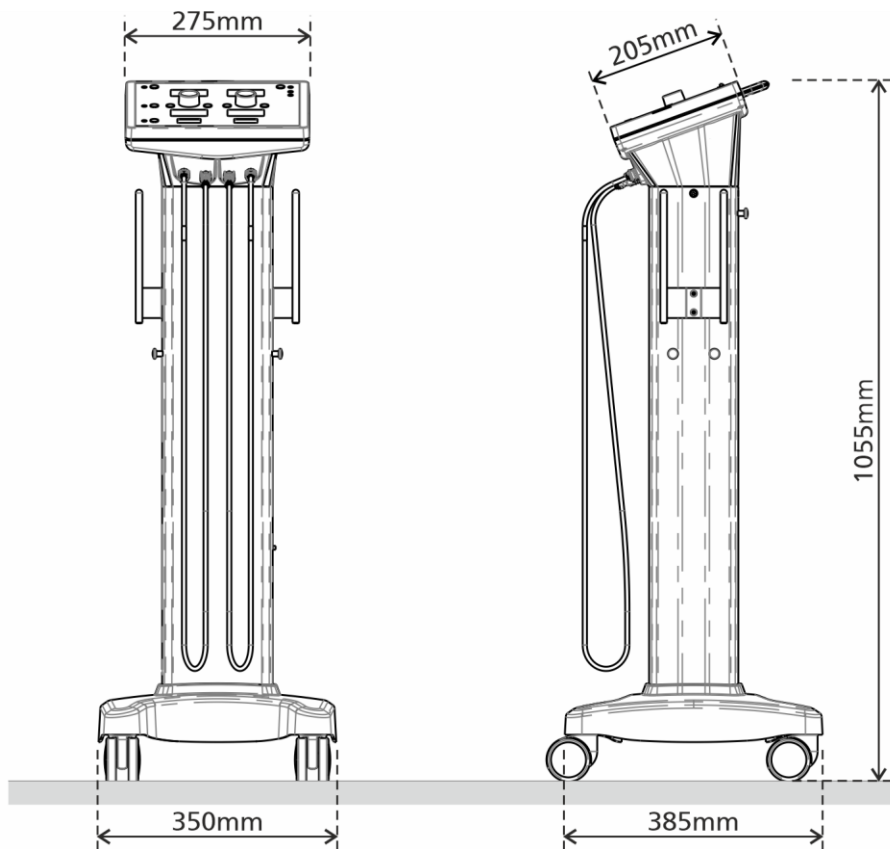

Accuracy and Resolution:	Pressure is measured to an accuracy of +/- 2.5 mmHg and displayed with a resolution of 5 mmHg.
Maximum Cuff Pressure:	The maximum cuff pressure is set to 600mmHg.
Input Electrical:	Mains electricity supply factory set to either; <ul style="list-style-type: none"> - 230V 50-60 Hz - 110-120V 50-60HZ See label beside mains inlet for voltage your unit has been set to.
Battery Type:	Sonnenschein A512/6.5 S NGA51206D5HS0SA.
Fuse:	Battery T3.15A 250V 20mm 230V supply 2 X Mains fuse T630mA 250V 20mm 110-120 V Supply 2 X Mains fuse T1A 120-250V 20mm
Safety:	Earth connection as per EN IEC 60601-1 class 1
Weight:	Excluding accessories but with batteries fitted, 17.3 Kg.
IP Rating:	IP41
Standards Applied:	EN IEC 60601-1 and EN IEC 60601-1-2.

Environmental Conditions:
Operating Conditions:
<ul style="list-style-type: none"> – Temperature of 15°C to 35°C. – Humidity of 20% to 80% non-condensing. – Height above sea level to be less than 2000m.
Movement and Storage Between Use:
<ul style="list-style-type: none"> – Temperature of 5°C to 40°C. – Humidity of ≤ 80% non-condensing. – Atmospheric Pressure 50kPa - 113kPa. – Floor to be level to within 10° of horizontal when being moved. – Not suitable for negotiating steps or thresholds.
Initial Transport and Storage in Original Packaging:
<ul style="list-style-type: none"> – Temperature of -20°C to 40°C. – Humidity of 20% - 90% non-condensing. – Atmospheric Pressure 50kPa - 113kPa.

EMC Data:
<p>Electromagnetic Disturbances; The AT4 Tourniquet is compliant to EN IEC 60601-1-2:2015 the “Collateral standard for Electromagnetic disturbances - Requirements and tests” and is accordingly classified as a Class A device for professional use.</p> <p>To reduce the risks of electromagnetic interference best practice as detailed below should be observed.</p> <ul style="list-style-type: none"> – If it is necessary to use the AT4 Tourniquet in close proximity to other electrical equipment, observe the performance of both the AT4 Tourniquet and the other equipment to make sure that they are operating normally. Ensure cables are not coiled or bundled in close proximity to each other and are separated from other cables where possible. – The AT4 Tourniquet is suitable for use in hospital operating rooms and other clinical areas with antistatic flooring. The emissions characteristics of this equipment make it suitable for use in hospitals, it is not intended for use in a residential environment. – To reduce risks of interference electromedical equipment should not be placed in close proximity to radio frequency communication equipment or electrosurgical equipment. Interference may occur in the vicinity of equipment marked with the symbol indicated. – If interference occurs the user may need to take mitigation measures, such as moving or reorienting the equipment or separating cables.



9. Cleaning and Disinfecting

The AT4, and its detachable hoses/cables must ***NOT*** be immersed in water or other liquids during cleaning or disinfection. Do ***NOT*** use solvents or abrasive cleaners

Cleansers and disinfectants must be CE marked indicating an intended purpose of medical devices & specified for use on plastics and metal surfaces. Suitable disinfectants include: quaternary ammonium compounds, isopropyl alcohol, chlorine or chlorine dioxide 0.5% and phenolics.



CAUTION: Before cleaning, disconnect from the mains electrical supply.

Wipe the AT4 and its detachable hoses/cables using a cloth dampened with detergent diluted with water as per the manufacturer’s instructions. Apply the liquid to the cloth and squeeze out surplus liquid. Do not apply liquid directly to the AT4 or its detachable parts.

After cleaning disinfect the AT4 and its detachable hoses and cables using a cloth dampened with disinfectant which is indicated for use on plastic and metal and is diluted as per the manufacturer's instructions. Apply the liquid to the cloth and squeeze out surplus liquid. Do not apply liquid to the device. After the specified contact time wipe dry with a clean dry cloth.

CAUTIONS:



- Disinfectant products are corrosive in nature; failure to properly wipe and dry the surfaces could leave a corrosive residue which may cause damage.
- Do not steam clean or jet wash any areas.
- Do not use concentrated bleaching disinfectant solutions, organic solvents, abrasive powders or expose any part of the device to excessive heat.



WARNING: It is recommended that only CE marked cleansers and disinfectants are used to clean the AT4. Dilute all disinfectants in accordance with the manufacturer's guidelines.

10. Installation of Battery

The battery is recharged from the mains and requires to be replaced every two years during scheduled service.

It is recommended that when not in use the device is connected to the mains electrical supply to recharge the battery. The battery will not be damaged by leaving it connected to the mains when fully charged.

To determine the battery status;

- Disconnected from the mains,
- Turn on,
- Wait for 30 seconds until the battery indicator ceases alternating colours and obtains a single stable colour,
- Red or Amber the device can only be used while remaining connected to the mains supply,
- Green can be used on battery power without connection to the mains.

When the Electrically powered unit is being used while *NOT* connected to the mains supply the following battery indications status applies;

Amber: Low battery connect to mains as soon as soon as practical.

Red: Extremely low battery, connect to mains immediately.

Green: Normal operation condition.

When the electronic unit is connected to the mains supply but *NOT* in use;

Amber: Indicates connection to the mains. This is *NOT* an indication of battery level.

When the electronic unit is being used while connected to the mains supply;

Green/Amber: Alternating Green/Amber indicating connection to the mains while in use.

NOTE: The amber indicator will take approximately 30 seconds to extinguish after disconnection from the mains.

11. Expected battery life

When running on DC power only, a fully charged unit should be able to perform the following number of bi-lateral 30 minute procedures at 300mmHg;

- 35* times with battery indicator displaying green
- A further 15* times with battery indicator displaying amber

Once the battery indicator begins displaying red the device should only be used while remaining connected to the mains supply.

* Based on well-maintained battery.

12. Maintenance

12.1. Daily

Ensure that O rings, cuffs and associated hoses are in good condition before use. Those that are damaged or worn should be replaced.



CAUTION: Before use, ensure the device's functions operate correctly. Also visually inspect the device for any loose or damaged parts. If the device's performance or mode of operation changes from that specified or required the device should be taken out of service immediately. If after checking O rings, cuffs and associated hoses are in good condition the AT4 is still not operating as expected then request maintenance before returning the device to clinical use.

If there is any sign of damage or a change in performance the device should be taken out of clinical use and maintenance requested.



If the battery indicator of the electrically powered AT4 shows amber connect it to the mains electrical supply as soon as possible. If the indicator shows red connect to the mains electrical supply immediately. Green shows normal operating conditions



The spanner symbol with a yellow or red indicator requires investigation. If the indicator is not cleared by replacing leaking cuffs hoses and O rings and then restarting the AT4 a service should be requested

12.2. Recurrent (Periodic) Testing



CAUTION: In line with the MHRA Device Bulletin DB2006(5), maintenance work should only be conducted by suitably trained personnel following manufacturer's guidelines and approved parts.

It is recommended that the device is serviced, electrically safety tested and the performance and accuracy confirmed on an annual basis in accordance with the manufacturer's service schedule and EN IEC 62353:2007.

The electrically powered AT4 contains a lead acid battery pack which will require to be replaced every two years. The device is class I electrical safety with a protective earth, it is NOT classified as an applied part.

When requesting service ensure that both the Ref No and the Serial No are quoted. The Serial and Reference Numbers are located on a label on the rear of the device.

13. Product Warranty

The product, when new, is guaranteed to be free from defects in materials and workmanship and to perform in accordance with the manufacturer's specification for a

period of one year from the date of purchase from Anetic Aid Ltd or their approved Distributor. Anetic Aid Ltd will repair or replace, at their discretion, any components found to be defective or at variance with the manufacturer's specification within this time at no cost to the purchaser. The warranty will take effect from the date of purchase, subject to the purchaser registering the product with Anetic Aid to confirm its receipt, installation date and product details.

The warranty does not provide cover for breakage or failure due to tampering, misuse, neglect, accidents, modifications or shipping. The warranty is also void if the product is not used in accordance with the manufacturer's instructions or is repaired during the warranty period by any persons other than Anetic Aid or its appointed agent. No other expressed or implied warranty is given.

For details of our extended warranty packages please contact Anetic Aid or your authorised dealer.

14. Disposal of Waste Electrical & Electronic Equipment

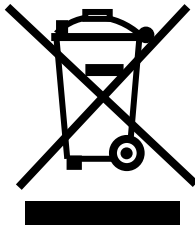

This symbol on the products and/or accompanying documents means that used electrical and electronic products should not be mixed with general waste.

Disposing of this product correctly will save valuable resources and prevent any potential negative effects on human health and the environment which could otherwise arise from inappropriate waste handling. If you are unsure of your national requirements with respect to disposal please contact your local authority, dealer or supplier for further information.

Penalties may be applicable for incorrect disposal of this waste, in accordance with national legislation. The above information is based on the European waste electrical and electronic equipment directive 2002/96/EC. Please note the electrically powered AT4 contains a lead acid battery pack which will require to be replaced every two years.

This page has been left blank.

AT4

Tourniquet System

For more information on any of our products or service contracts, call:

+44 (0) 1943 878647

sales@aneticaid.com

aneticaid.com



Rx ONLY

Manufactured by:

Medical Device Management Ltd.
31 Braintree Business Park,
Braintree,
Essex,
CM7 2PU,
United Kingdom



Medical Device Management Ltd.
Block B, The Crescent Building, Northwood,
Santry, Dublin 9, DO9 C6X8, Ireland.

Distribution, Sales and Service by:

Anetic Aid Ltd.
44 New Lane,
Havant,
Hampshire,
PO9 2NF,
United Kingdom

