

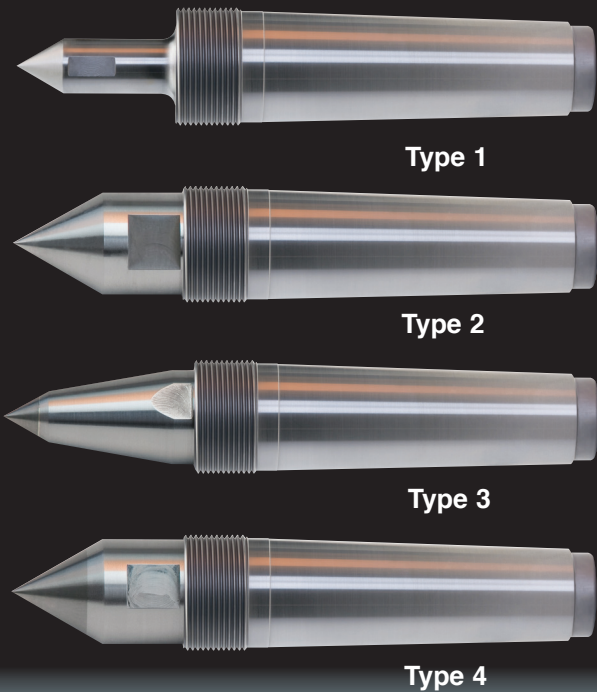

Mazak CNC Dead Centers

Special tapers for
Mazak machines



CNC Dead Centers (see reverse for Bell Head Dead Centers)

- Accuracy guaranteed to $\pm .00005$
- Meet the rigid requirements of CNC turning
- Through-hardened to 61-63 Rc
- All models in stock
- Riten full service and repair

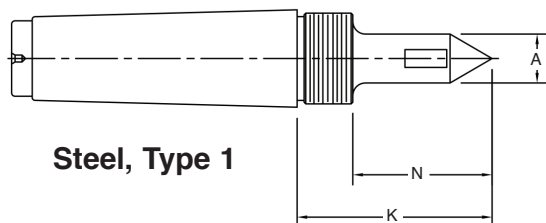

Steel, Type 1

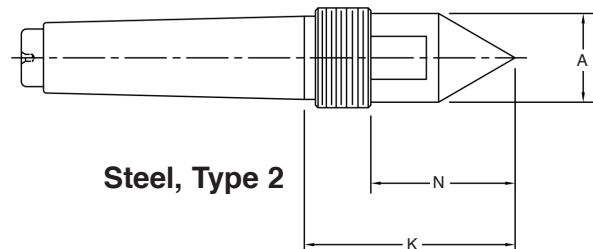

Steel, Type 2

STEEL, TYPE 1, MORSE TAPER

Model	MT	A	N	K	Threads	Nut
68184	4	.625	2.25	3.31	11/8 -12	81041
68185	5	.875	2.50	3.98	17/8 -12	86051
68186	6	1.75	3.69	5.83	2 1/2 -12	86061

STEEL, TYPE 2, MORSE TAPER

Model	MT	A	N	K	Threads	Nut
68684	4	1.25	2.04	3.22	13/8 - 12	86041
68685	5	1.75	2.52	4.00	17/8 - 12	86051
68686	6	2.63	2.75	5.07	3 -12	86062

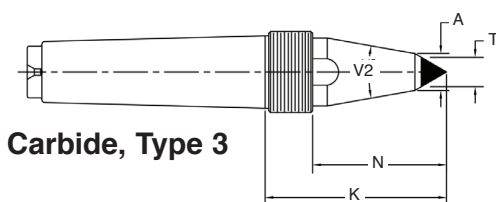

Carbide, Type 3

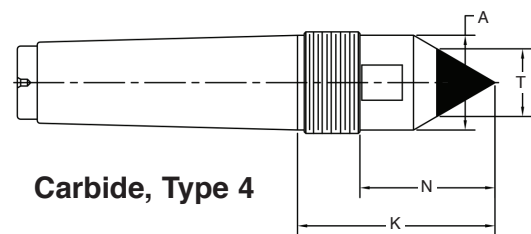

Carbide, Type 4

CARBIDE TIPPED, TYPE 3, MORSE TAPER

Model	MT	T	A	N	K	V2	Threads	Nut
68984	4	1/2	.63	2.28	3.46	20°	13/8 - 12	86041
68985	5	1/2	.63	2.50	3.95	20°	15/8 - 12	81051

CARBIDE TIPPED, TYPE 4, MORSE TAPER

Model	MT	T	A	N	K	Threads	Nut
68974	4	1.00	1.25	2.00	3.18	13/8 - 12	86041
68975	5	1.25	1.75	2.52	4.00	17/8 - 12	86051

Bell Head Dead Center Mandrels specially tapered for Mazak machines

- Accuracy guaranteed to $\pm .0001$ assembled
- Heat treated for additional strength

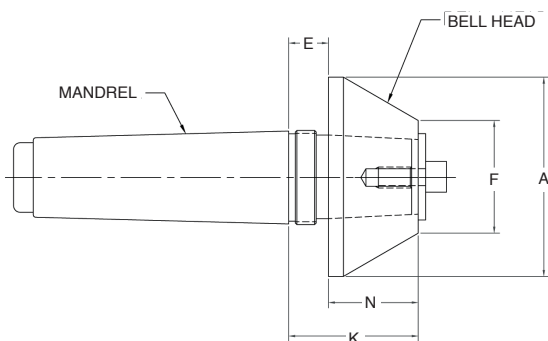

DEAD CENTER MANDRELS - MORSE TAPER

Model	MT	Threads	E	K	Bell Head
01124*	4	M35 x 1.5	1.25	2.94	Series 1
01125*	5	M45 x 1.5	1.25	2.94	Series 1
01126*	6	3.00-12	2.35	4.48	Series 2

Threaded mandrels include the extraction nut.

BELL HEADS (Series 1)

Model	A	F	N	Bell Head
01375	3.75	2.12	1.69	Series 1
01525	5.25	3.62	1.69	Series 1
01675	6.75	5.12	1.69	Series 1
01825	8.25	6.62	1.69	Series 1
01975	9.75	8.12	1.69	Series 1

BELL HEADS (Series 2)

Model	A	F	N	Bell Head
02045	4.50	2.50	2.13	Series 2
02055	5.50	3.33	2.13	Series 2
02075	7.50	5.33	2.13	Series 2
02095	9.50	7.33	2.13	Series 2
02115	11.50	9.33	2.13	Series 2
02135	13.50	11.33	2.13	Series 2

All Bell Heads are heat treated for additional strength.

Your local authorized Riten distributor:

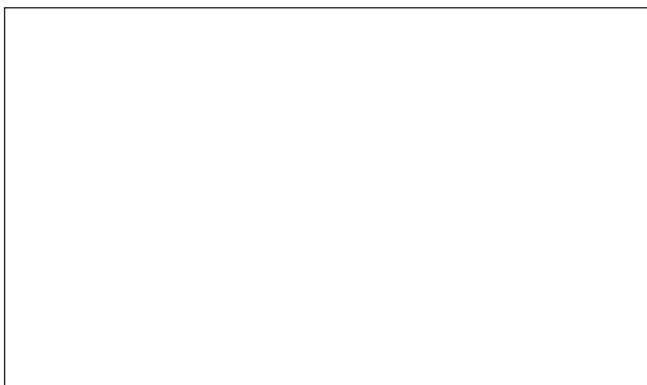

Riten[®]

Solutions, not excuses

Riten Industries, Inc.
 1100 Lakeview Avenue, P.O. Box 340
 Washington Court House, OH 43160 USA
 800-338-0027 • www.riten.com